



US00D490831S

(12) **United States Design Patent** (10) **Patent No.:** **US D490,831 S**
Raab et al. (45) **Date of Patent:** **** Jun. 1, 2004**

(54) **PORTABLE COORDINATE MEASUREMENT MACHINE**

www.romer.com—1000i Series System Package.

(List continued on next page.)

(75) Inventors: **Simon Raab**, Maitland, FL (US); **Seyed Ali Sajedi**, Winter Park, FL (US); **Kenneth J. Hasloeher**, Deltona, FL (US); **Marc Barber**, Deltona, FL (US)

Primary Examiner—Antoine Duval Davis
(74) *Attorney, Agent, or Firm*—Cantor Colburn LLP

(73) Assignee: **Faro Technologies, Inc.**, Lake Mary, FL (US)

(57) **CLAIM**

The ornamental design for a portable coordinate measurement machine, as shown.

(**) Term: **14 Years**

DESCRIPTION

(21) Appl. No.: **29/175,949**

(22) Filed: **Feb. 13, 2003**

Related U.S. Application Data

(63) Continuation-in-part of application No. 29/166,332, filed on Aug. 26, 2002, now Pat. No. Des. 479,544, which is a continuation-in-part of application No. 29/155,790, filed on Feb. 14, 2002, now Pat. No. Des. 472,824.

(51) **LOC (7) Cl.** **15-99**

(52) **U.S. Cl.** **D15/199**

(58) **Field of Search** D15/199; 33/1 M, 33/503-506, 556-561; 74/409.02; 702/150

(56) **References Cited**

U.S. PATENT DOCUMENTS

4,593,470 A	6/1986	Davies	33/1
4,676,002 A	6/1987	Slocum	33/1
4,937,759 A	6/1990	Vold	364/513

(List continued on next page.)

FOREIGN PATENT DOCUMENTS

DE	42 31 040 A1	3/1994
DE	101 12 977 C1	2/2002
EP	0 155 084 A1	9/1985

(List continued on next page.)

OTHER PUBLICATIONS

<http://scanworks.perceptron.com/products>.
<http://scanworks.perceptron.com>.

FIG. 1 is a front perspective view of our new portable coordinate measurement machine;
 FIG. 2 is a front view thereof;
 FIG. 3 is a rear view thereof;
 FIG. 4 is a right side view thereof with the left side view being a mirror image thereof;
 FIG. 5 is a top view thereof;
 FIG. 6 is a bottom view thereof;
 FIG. 7 is a front perspective view of a second embodiment of our new portable coordinate measurement machine;
 FIG. 8 is a front view thereof;
 FIG. 9 is a rear view thereof;
 FIG. 10 is a right side view thereof with the left side view being a mirror image thereof;
 FIG. 11 is a top view thereof;
 FIG. 12 is a bottom view thereof;
 FIG. 13 is a front perspective view of a third embodiment of our new portable coordinate measurement machine;
 FIG. 14 is a front view thereof;
 FIG. 15 is a rear view thereof;
 FIG. 16 is a right side view thereof with the left side view being a mirror image thereof;
 FIG. 17 is a top view thereof;
 FIG. 18 is a bottom view thereof;
 FIG. 19 is a front perspective view of a fourth embodiment of our new portable coordinate measurement machine;
 FIG. 20 is a front view thereof;
 FIG. 21 is a rear view thereof;
 FIG. 22 is a right side view thereof with the left side view being a mirror image thereof;
 FIG. 23 is a top view thereof; and,
 FIG. 24 is a bottom view thereof.

1 Claim, 12 Drawing Sheets

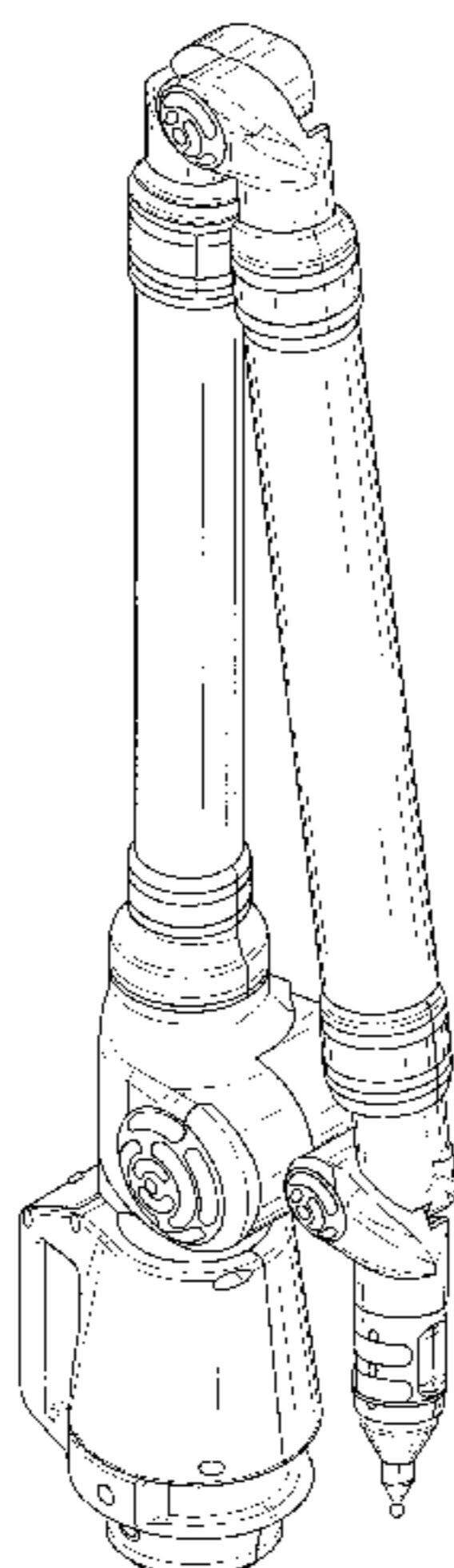

US D490,831 S

Page 2

U.S. PATENT DOCUMENTS

5,050,608 A	9/1991	Watanabe et al.	128/653
5,086,401 A	2/1992	Glassman et al.	395/94
5,189,797 A	3/1993	Granger	33/1
D344,279 S	2/1994	Koyama et al.	D15/199
5,412,880 A	5/1995	Raab	33/503
D377,932 S	2/1997	Schena et al.	D14/114
5,611,147 A	3/1997	Raab	33/503
5,724,264 A	3/1998	Rosenberg et al.	364/559
5,768,792 A	6/1998	Raab	33/503
5,807,449 A	9/1998	Hooker et al.	156/64
5,829,148 A	11/1998	Eaton	33/503
D410,477 S	6/1999	Nihei et al.	D15/199
5,978,748 A	11/1999	Raab	702/150
D423,534 S	4/2000	Raab et al.	D15/199
6,131,299 A	10/2000	Raab et al.	33/503
6,151,789 A	11/2000	Raab et al.	33/503

FOREIGN PATENT DOCUMENTS

FR	86 06186	4/1986
FR	2 634 379	7/1988
GB	2 264 601 A	1/1993

GB	2 264 602 A	1/1993
JP	56062783	5/1981
JP	57073602	5/1982
JP	2168303	6/1990
JP	2212085	8/1990
WO	WO 94/15173	7/1994
WO	WO 98/08050	2/1998
WO	WO 01/63202 A1	2/2001

OTHER PUBLICATIONS

www.romer.com—3000i Specifications.
www.romer.com—Seventh Axis Linear Rail.
www.romeo.fr.
Takehis Komino, “Three Dimensional Coordinate Measuring System,” Vectoron, Model VSC-07, VSC-14, vol. 30, No. 12, pp. 52-59.
<http://www.kreon3d.com>.
<http://www.3dscanners.com/1999/htm>—pp. 1, 4, & 8.
<http://www.optimet.com/Sensors.htm>.
Portable 6 Axes Measuring System, Type AMPG, ZETT MESS Technik GmbH, D 53757 Sankt Augustin.

FIG. 1

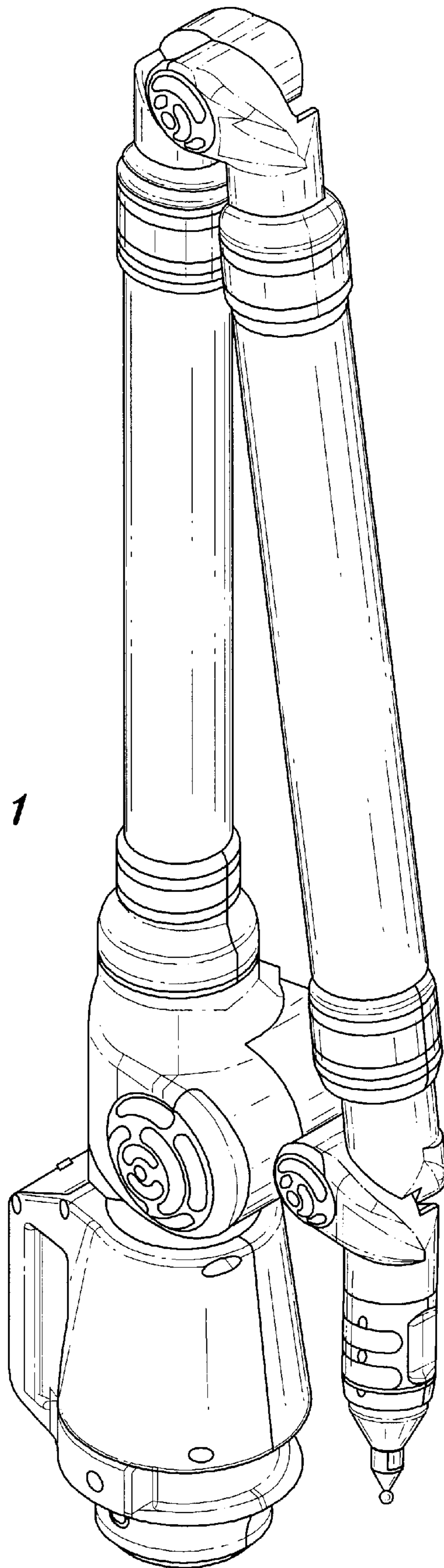

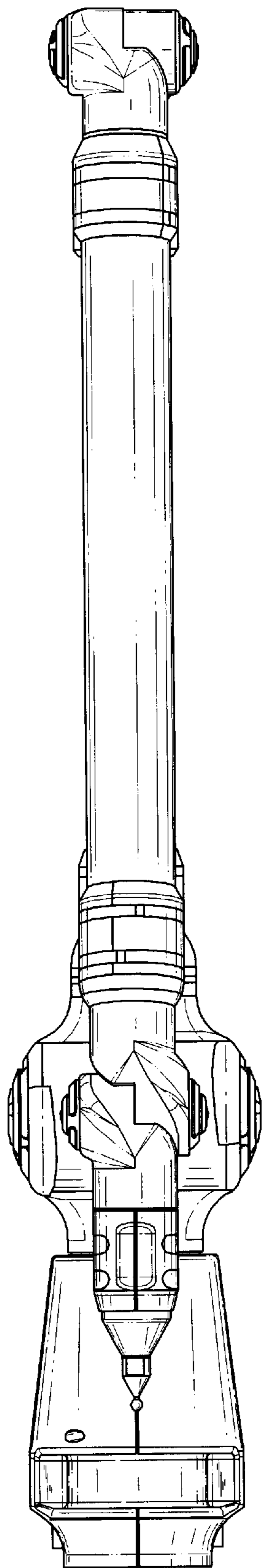

FIG. 2

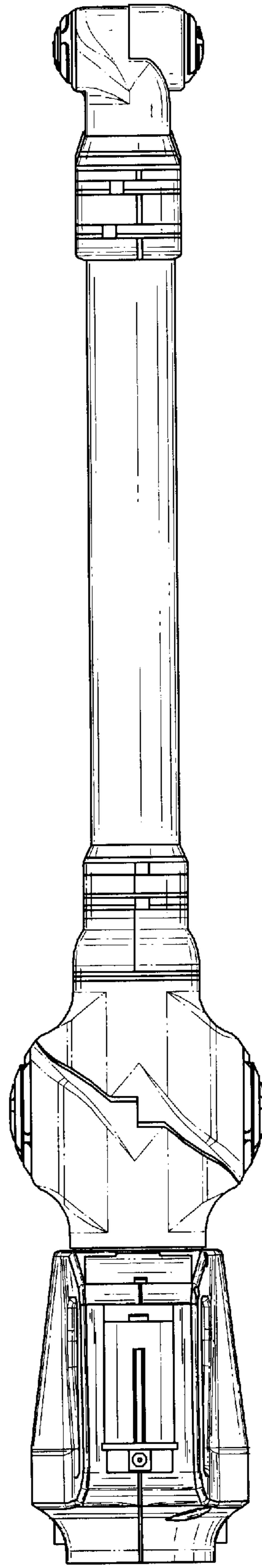

FIG. 3

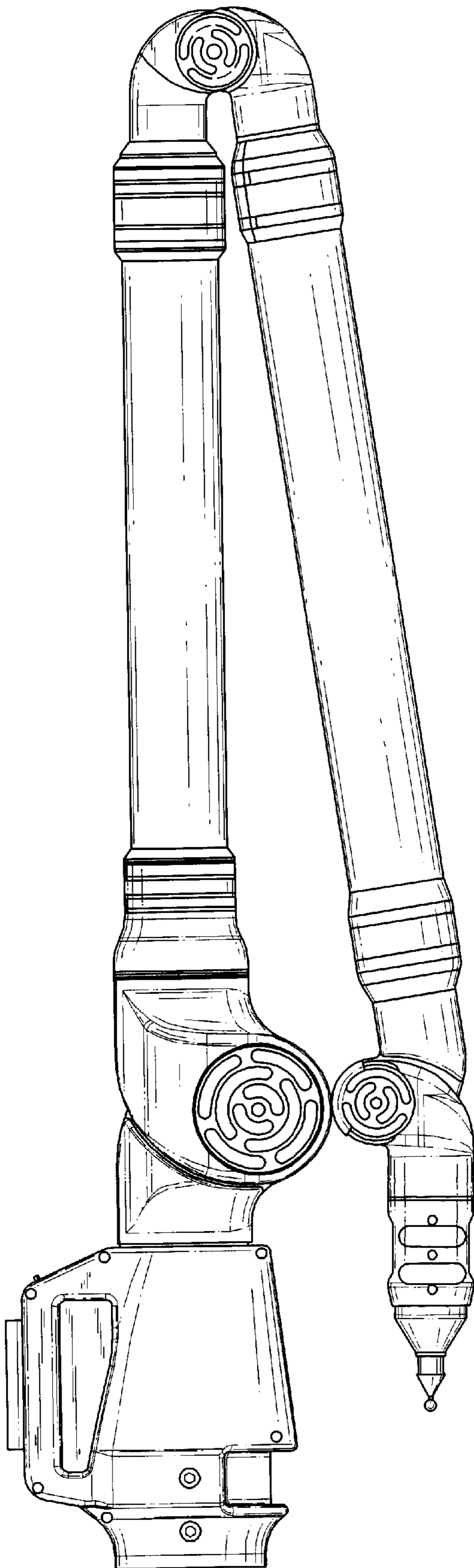

FIG. 4

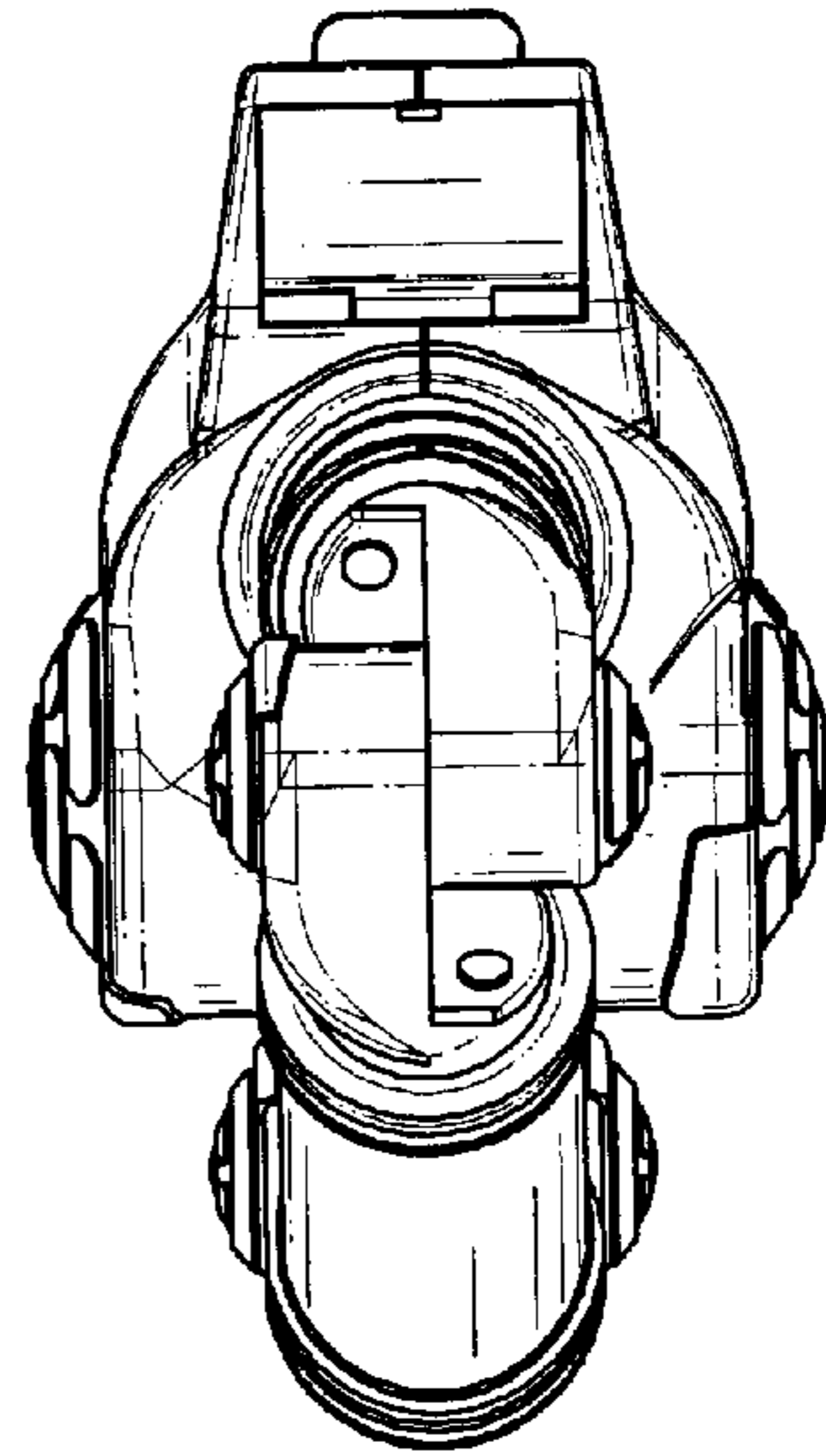

FIG. 5

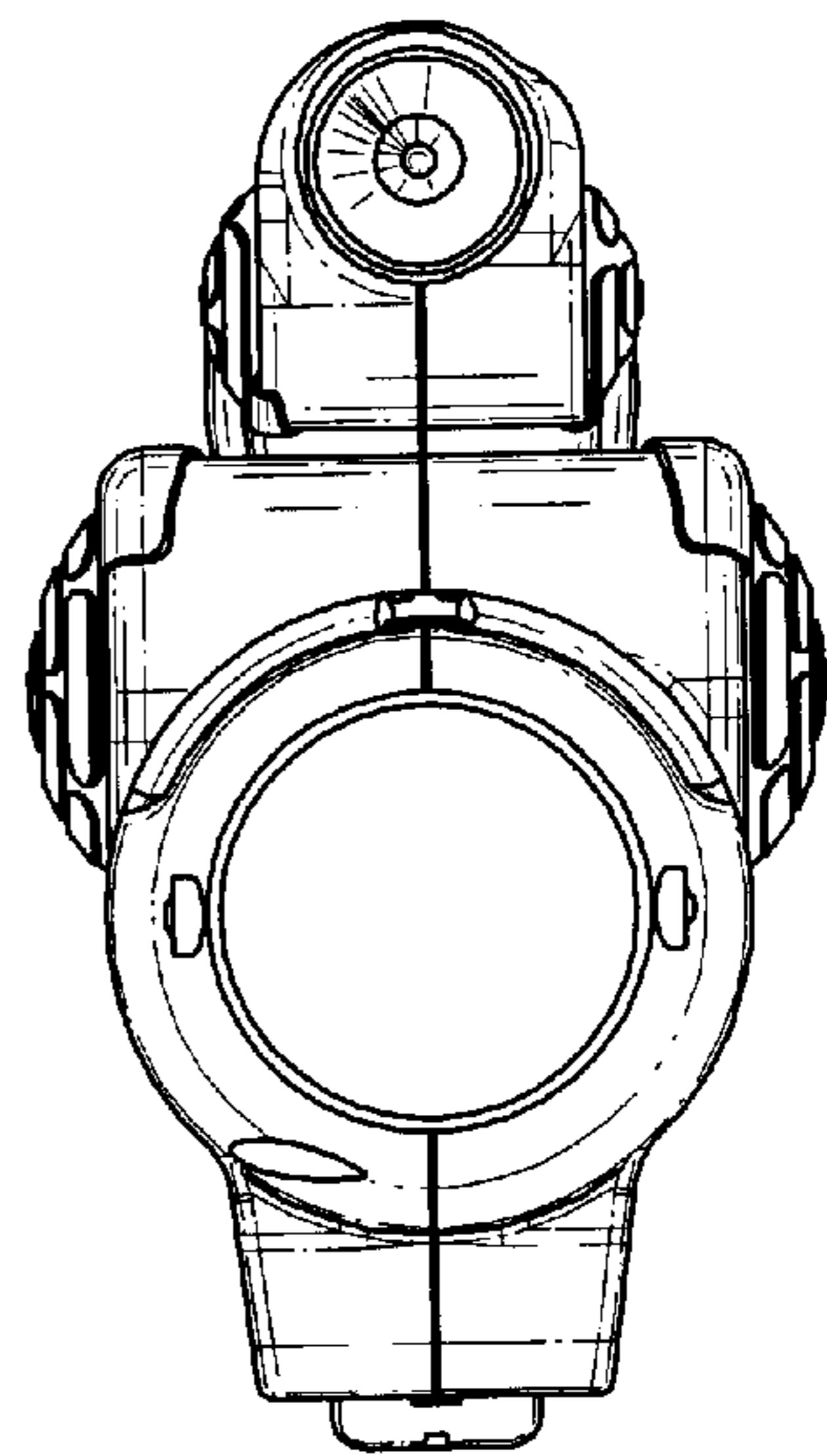
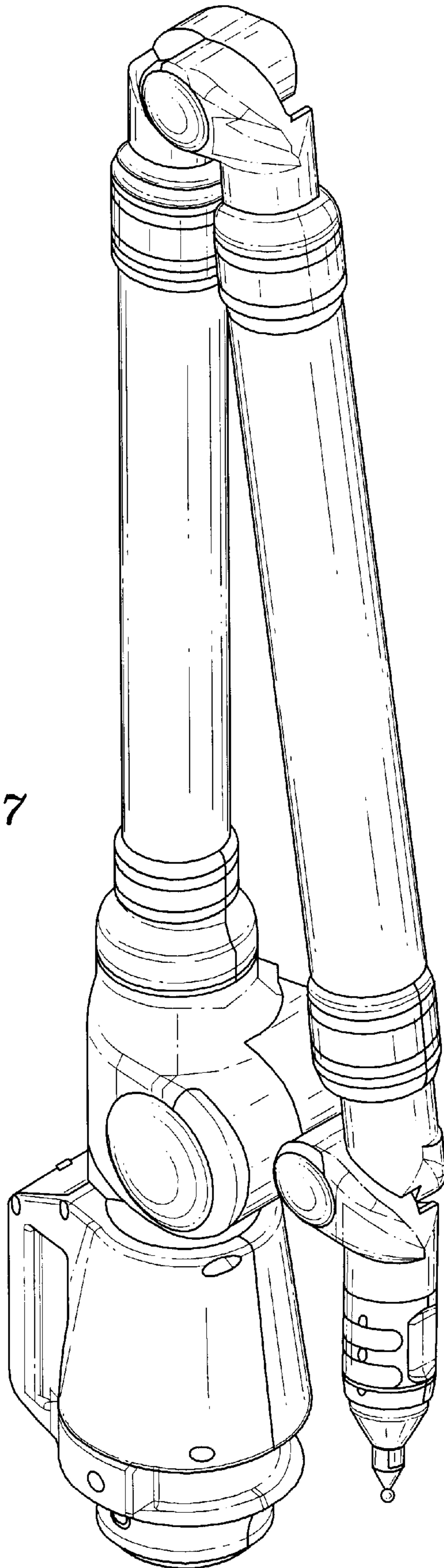

FIG. 6

FIG. 7



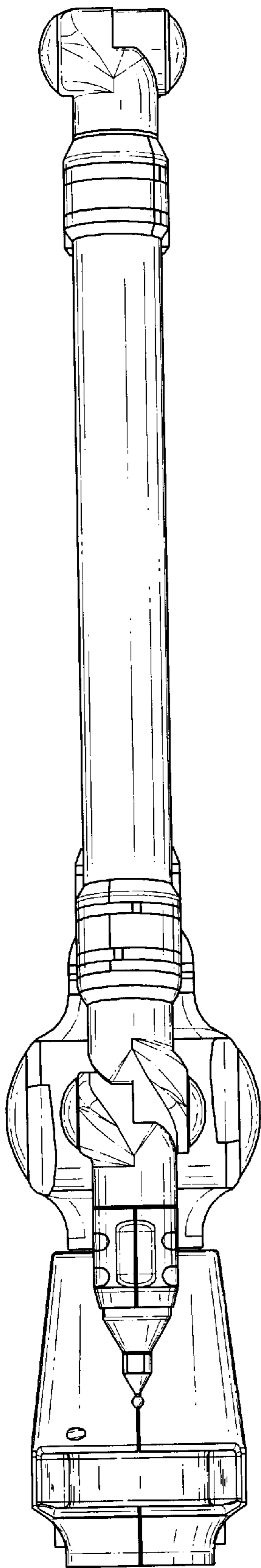

FIG. 8

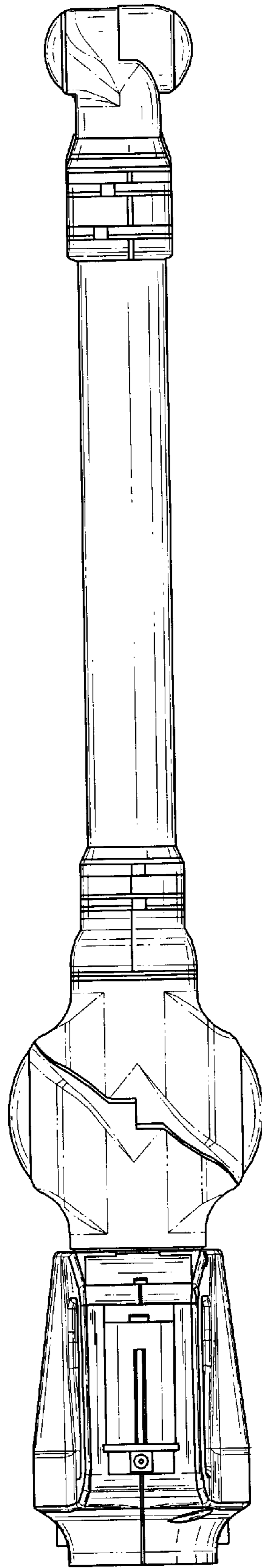

FIG. 9

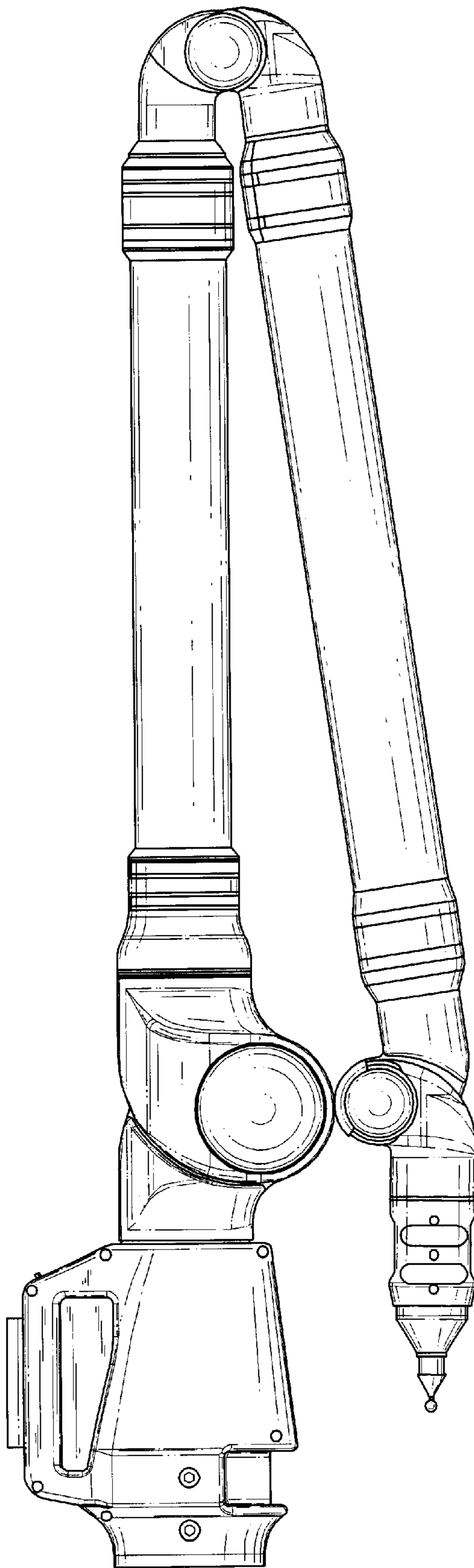

FIG. 10

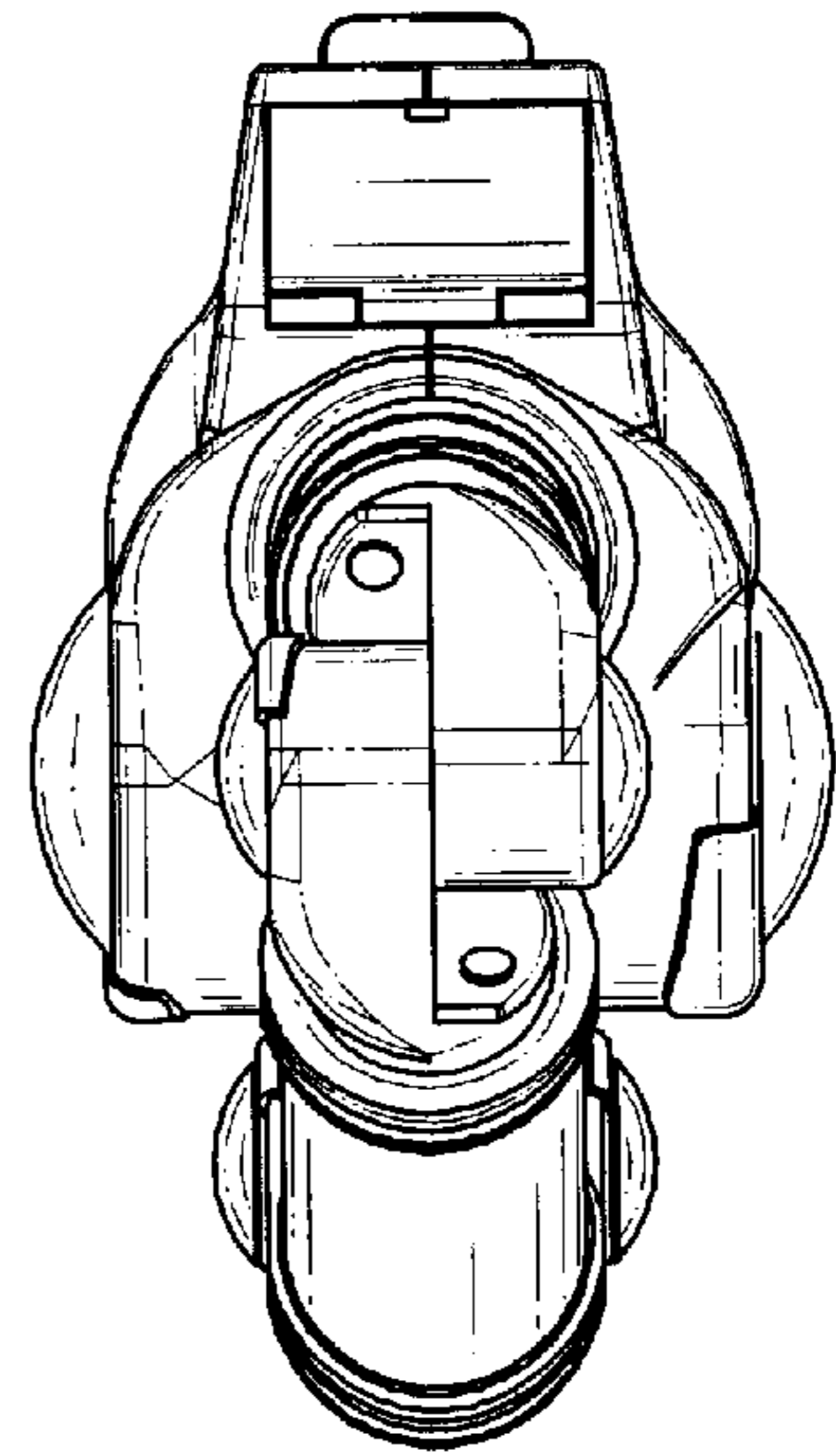

FIG. 11

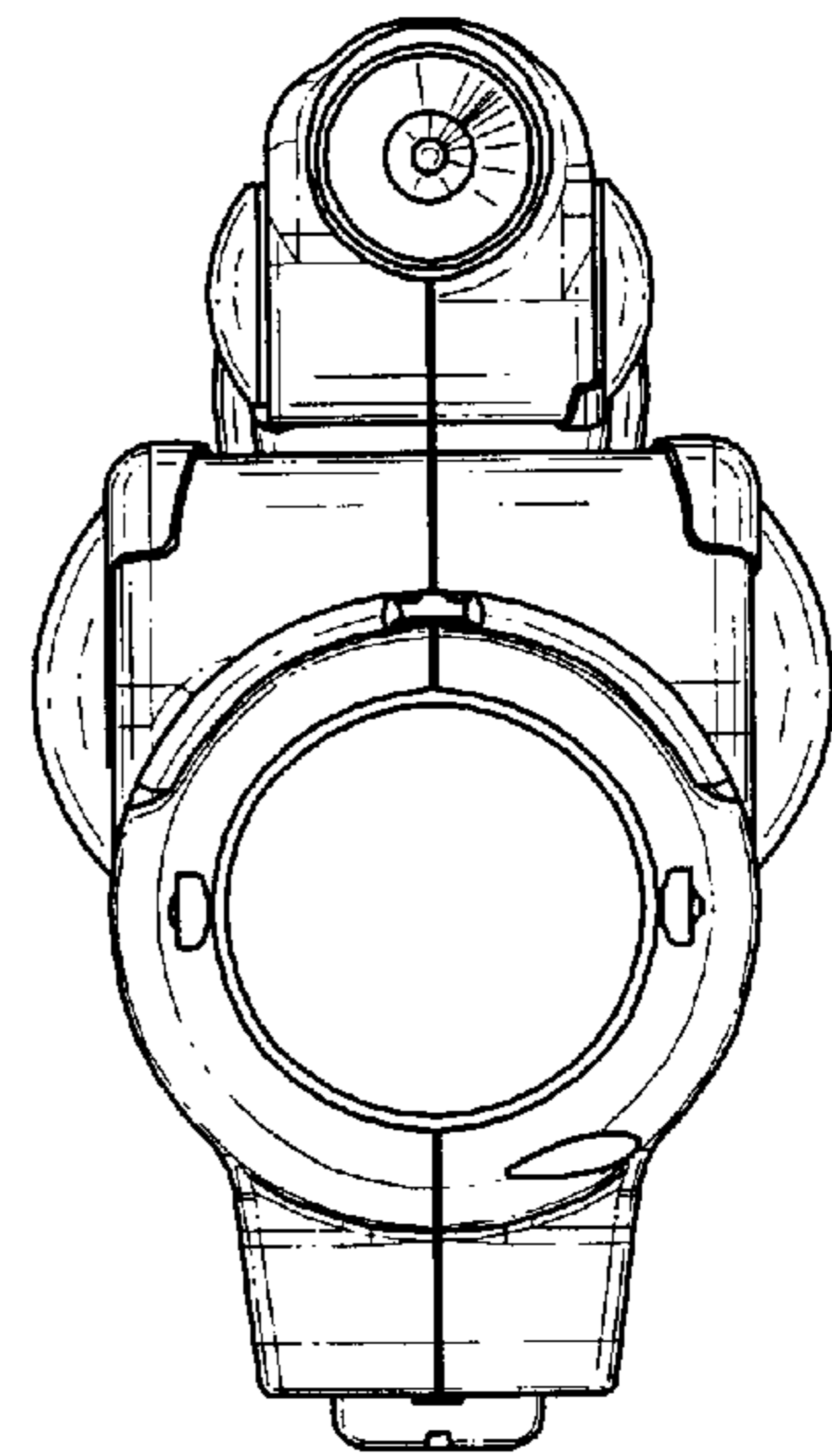

FIG. 12

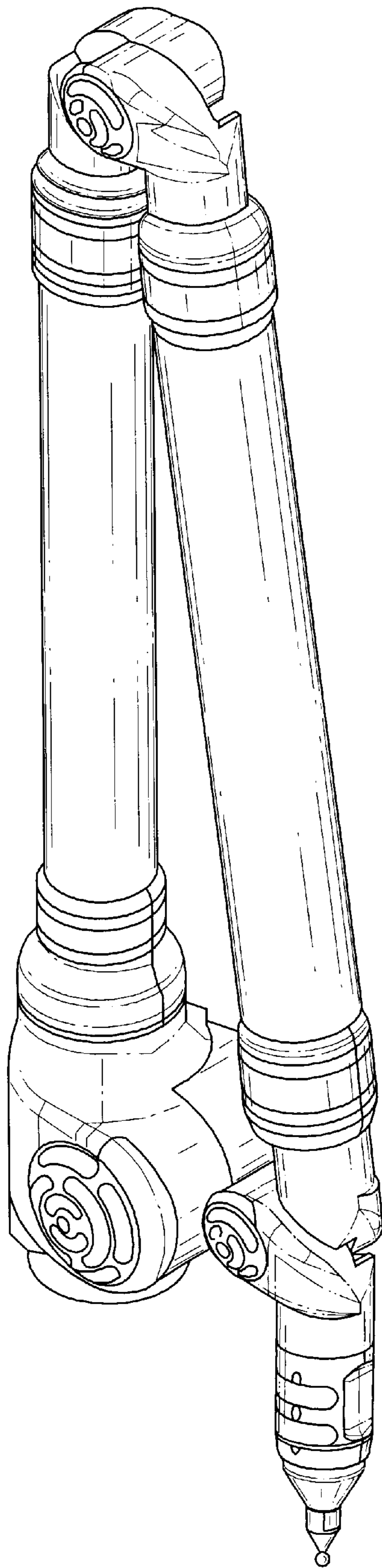

FIG. 13

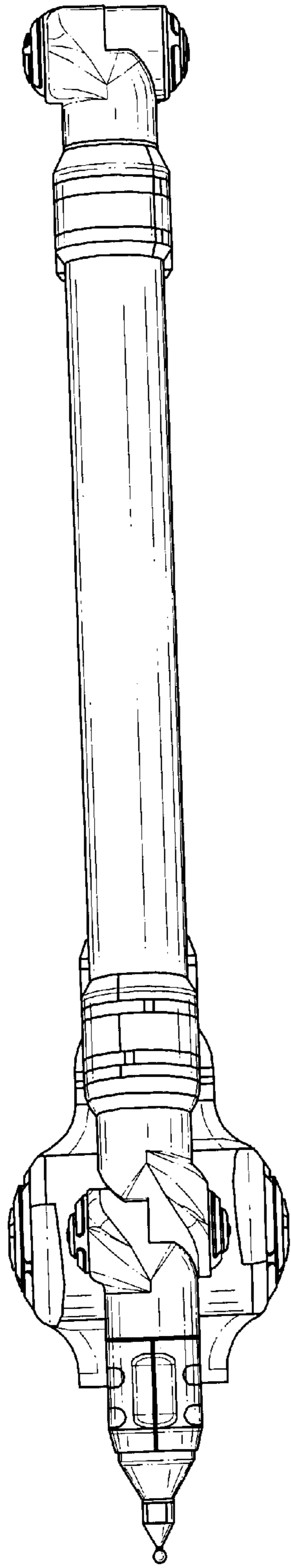

FIG. 14

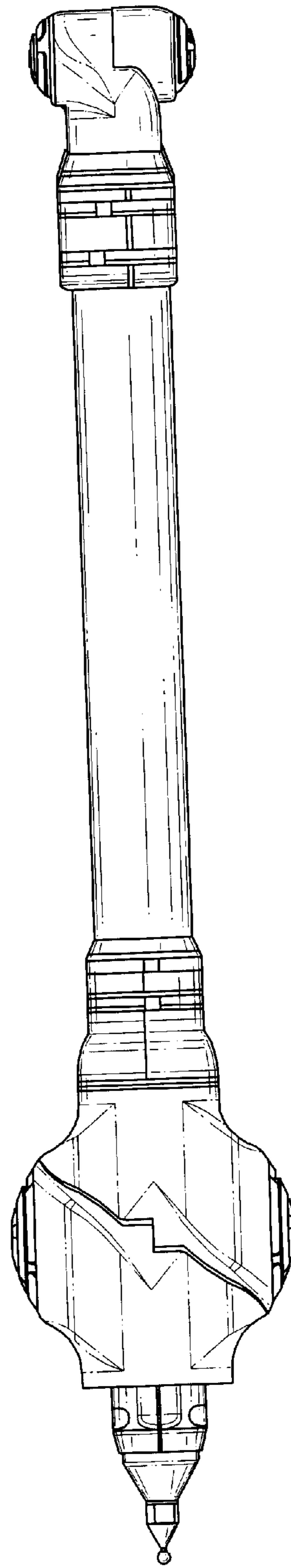

FIG. 15

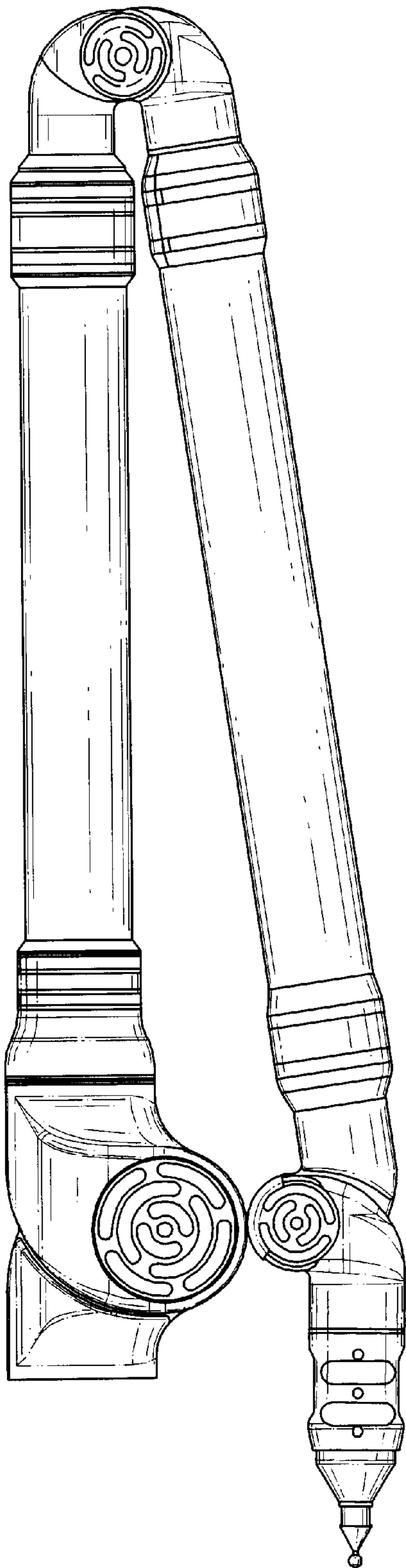

FIG. 16

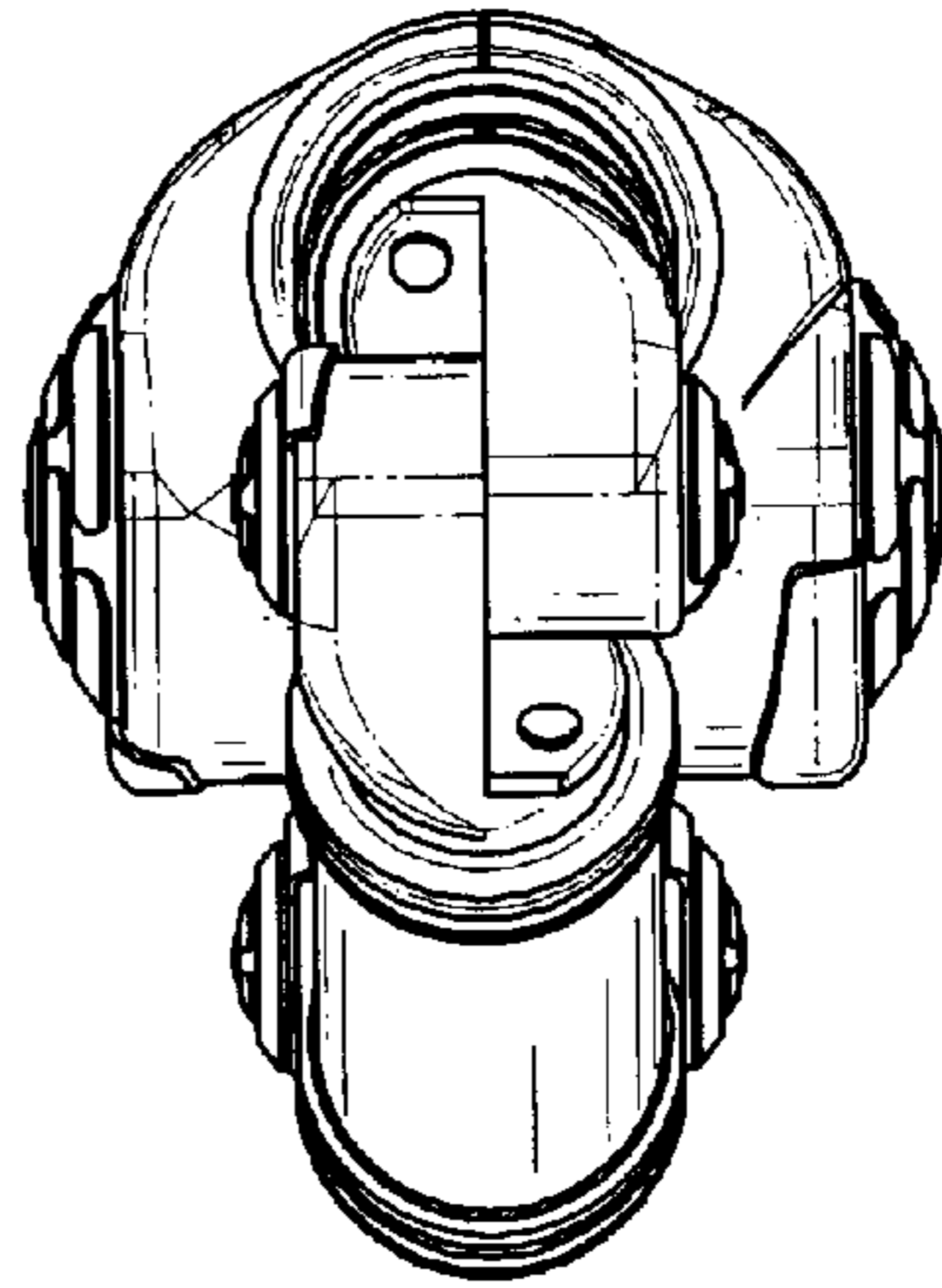

FIG. 17

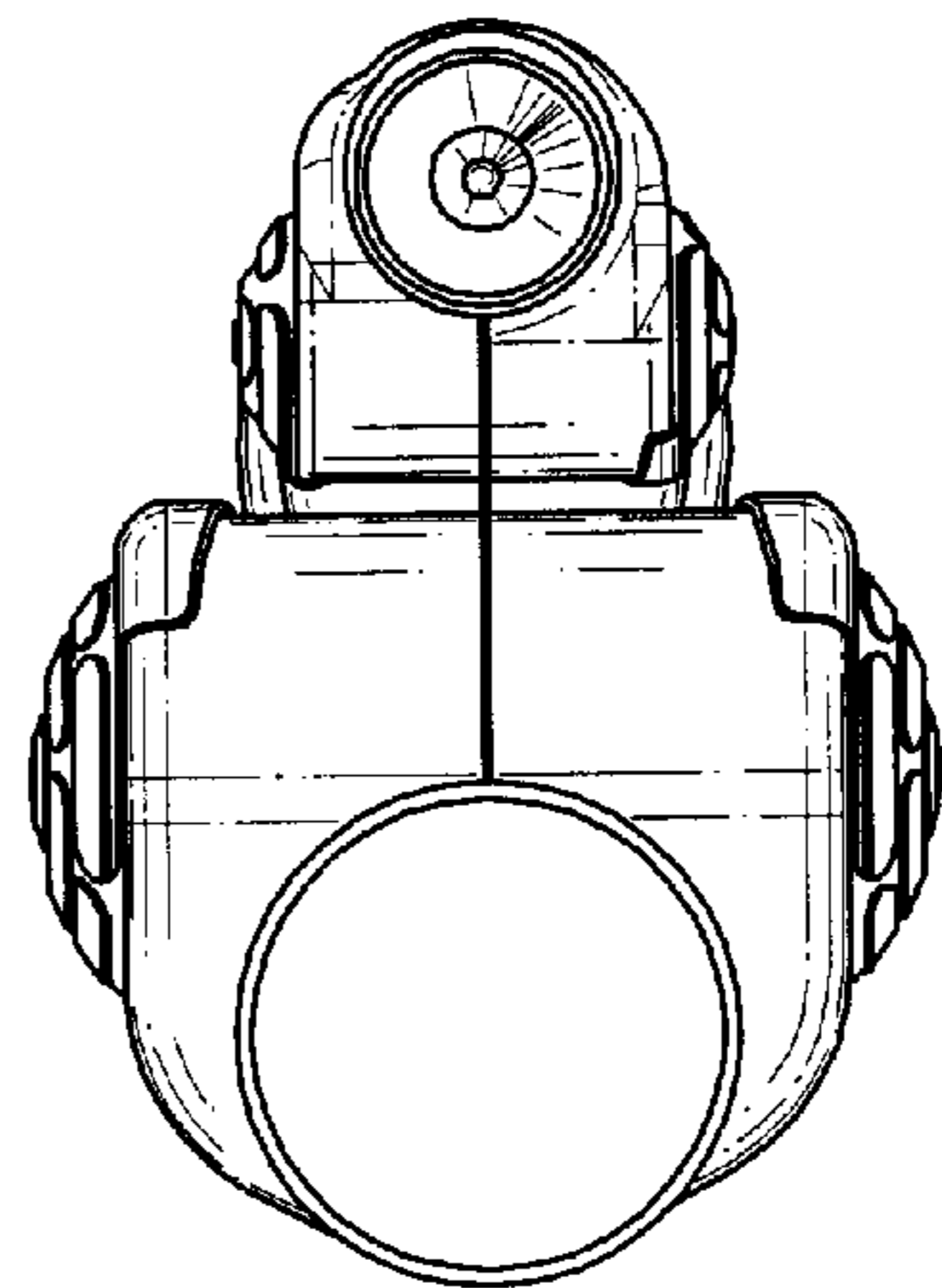

FIG. 18

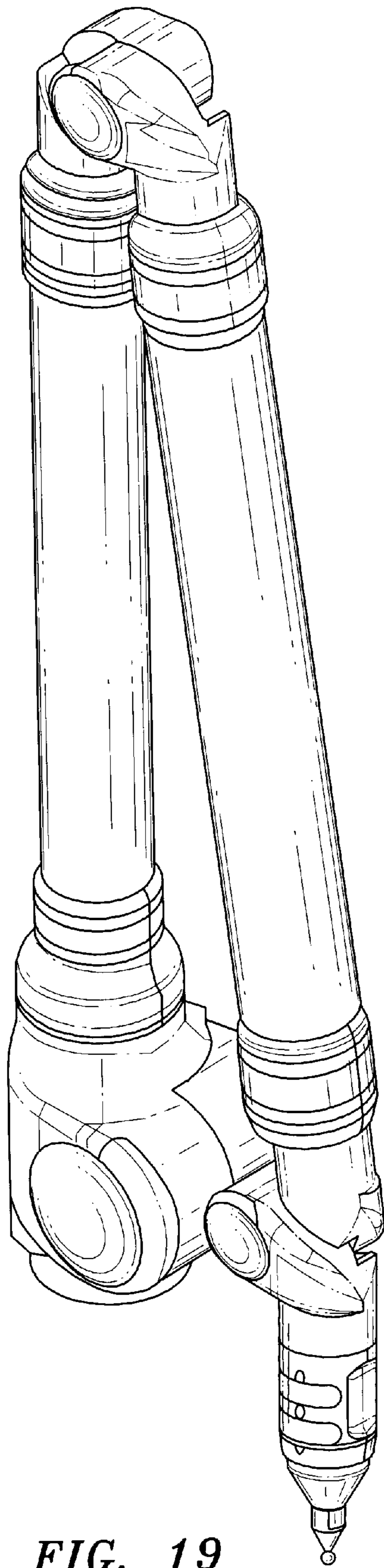

FIG. 19

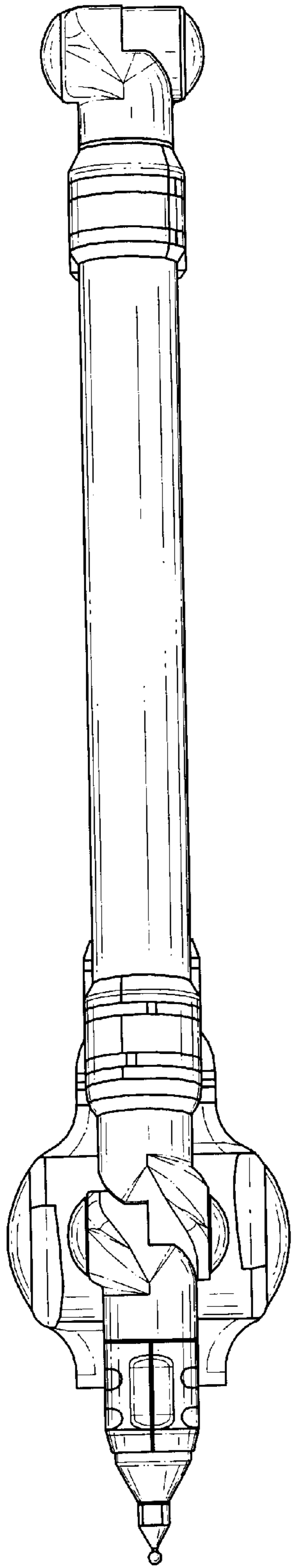

FIG. 20

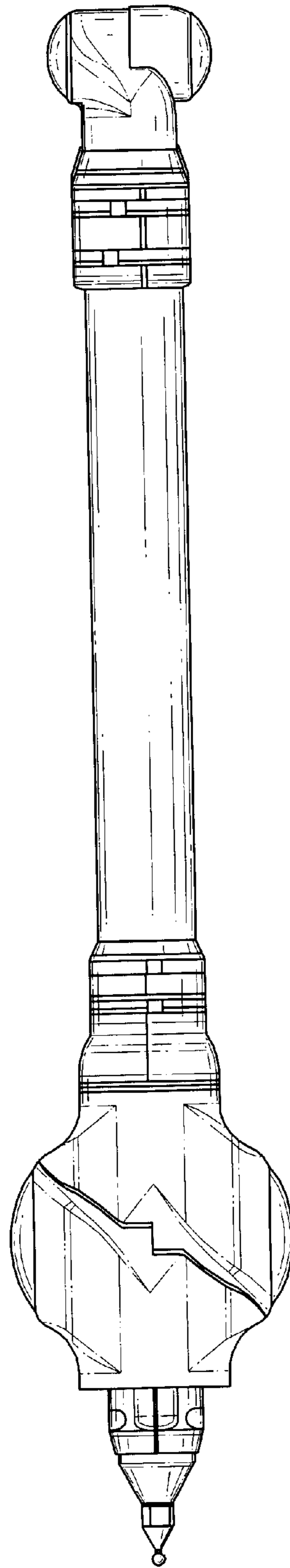

FIG. 21

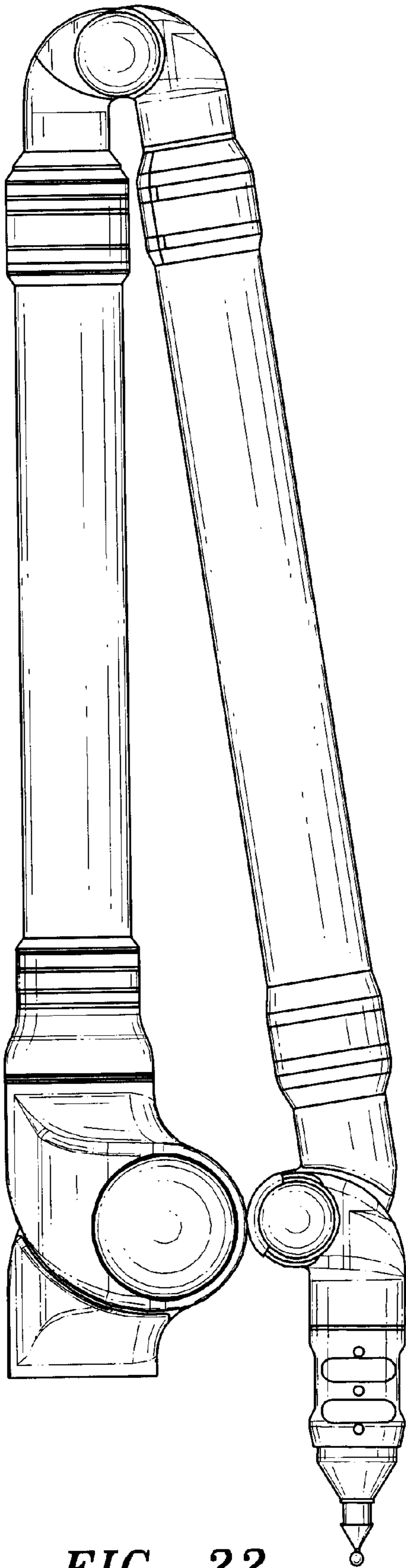

FIG. 22

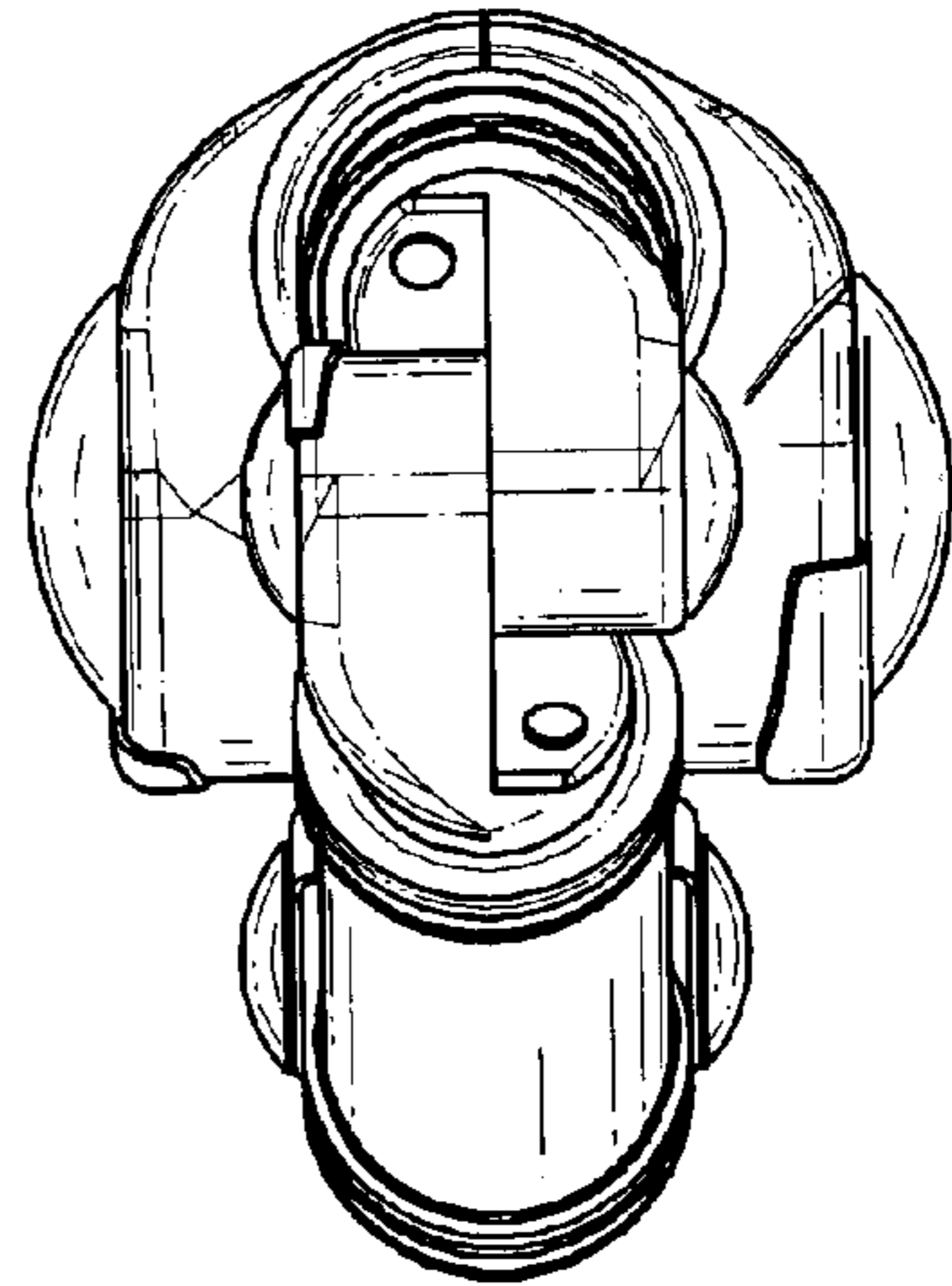

FIG. 23

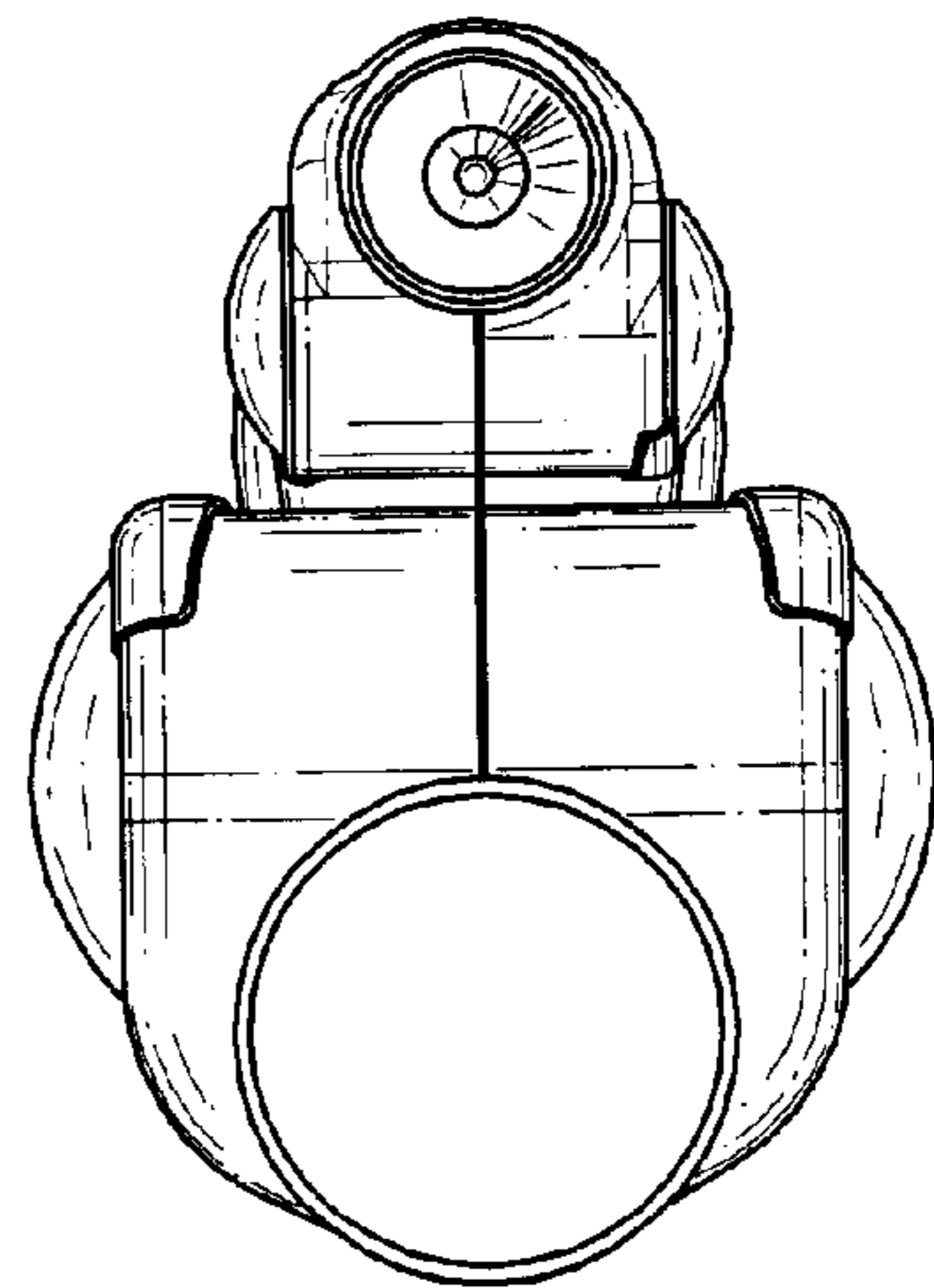

FIG. 24