



US00D490373S

(12) **United States Design Patent**
Tsergas

(10) **Patent No.:** **US D490,373 S**

(45) **Date of Patent:** **** May 25, 2004**

(54) **ICE CRUSHING MOTOR**

(75) **Inventor:** **Athanase N. Tsergas**, Wood Dale, IL (US)

(73) **Assignee:** **Molon Motor & Coil Corporation**, Rolling Meadows, IL (US)

(**) **Term:** **14 Years**

(21) **Appl. No.:** **29/172,364**

(22) **Filed:** **Dec. 11, 2002**

(51) **LOC (7) Cl.** **13-01**

(52) **U.S. Cl.** **D13/112**

(58) **Field of Search** D15/4, 148, 80; D13/112, 113; D7/372-374, 665; 310/40 R, 52, 58, 89, 91; 241/82.1, 83, 95, 100, 249, 285.1; 248/312.1; 62/340, 344, 353; 312/236, 401

(56) **References Cited**

U.S. PATENT DOCUMENTS

- D239,119 S * 3/1976 Dorsey D13/113
- D292,473 S * 10/1987 Fisher D7/402
- D298,434 S * 11/1988 Makihara D15/80

- D440,995 S * 4/2001 Tsergas et al. D15/148
- 6,276,160 B1 * 8/2001 Terada et al. 62/353
- D462,937 S * 9/2002 Nord D13/112
- D467,258 S * 12/2002 Tsergas D15/148

* cited by examiner

Primary Examiner—Melody N. Brown

(74) *Attorney, Agent, or Firm*—Oblon, Spivak, McClelland, Maier & Neustadt, P.C.

(57) **CLAIM**

The ornamental design for an ice crushing motor, as shown and described.

DESCRIPTION

FIG. 1 is a top plan view of an ice crushing motor, showing my new design.

FIG. 2 is a right side elevational view thereof.

FIG. 3 is a bottom plan view thereof.

FIG. 4 is a front end view thereof.

FIG. 5 is a rear end view thereof; and,

FIG. 6 is a top, front, side perspective view thereof.

The left side elevational view is not shown because it is identical to the right side elevational view.

1 Claim, 3 Drawing Sheets

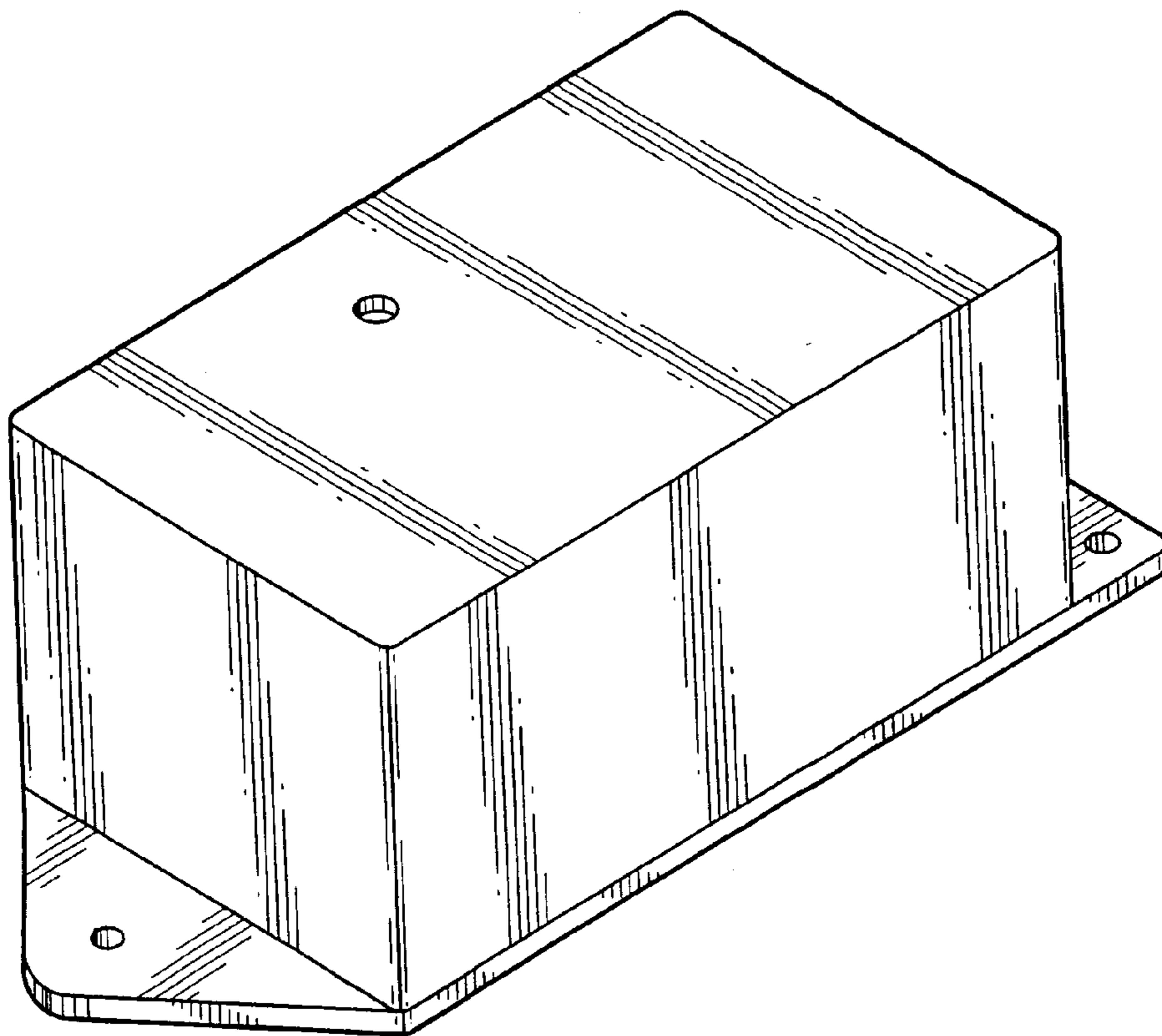

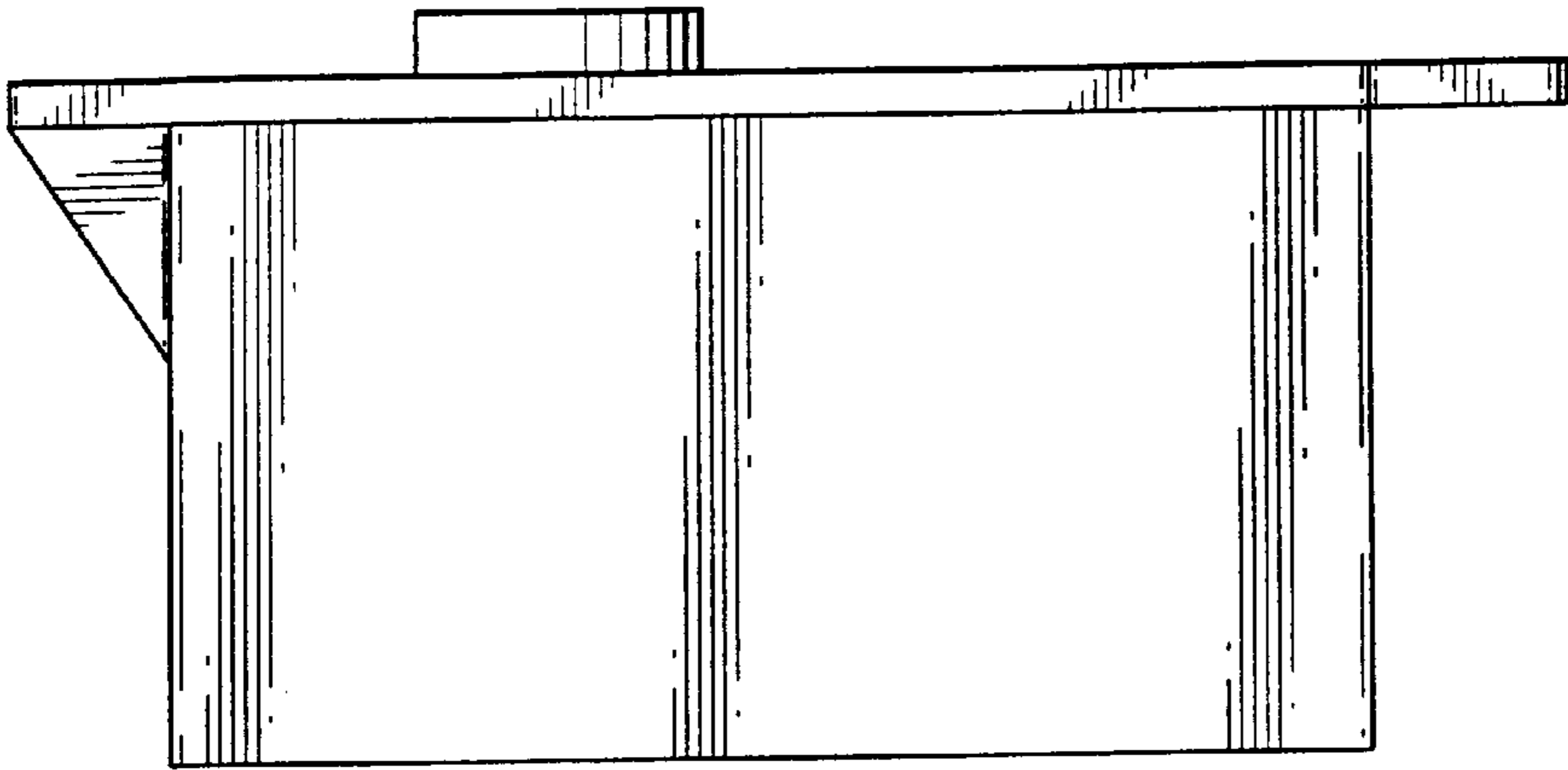

FIG. 2

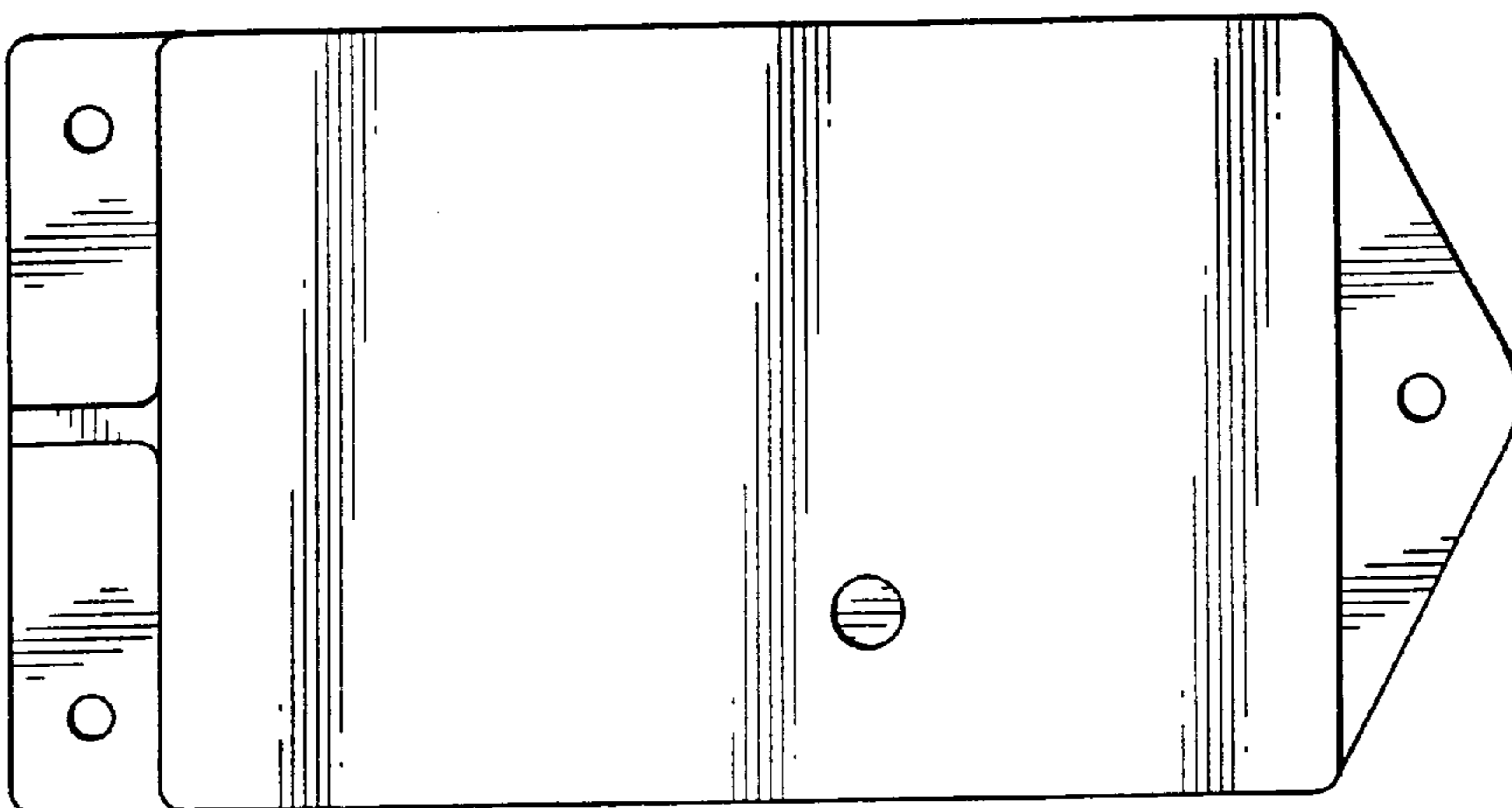

FIG. 1

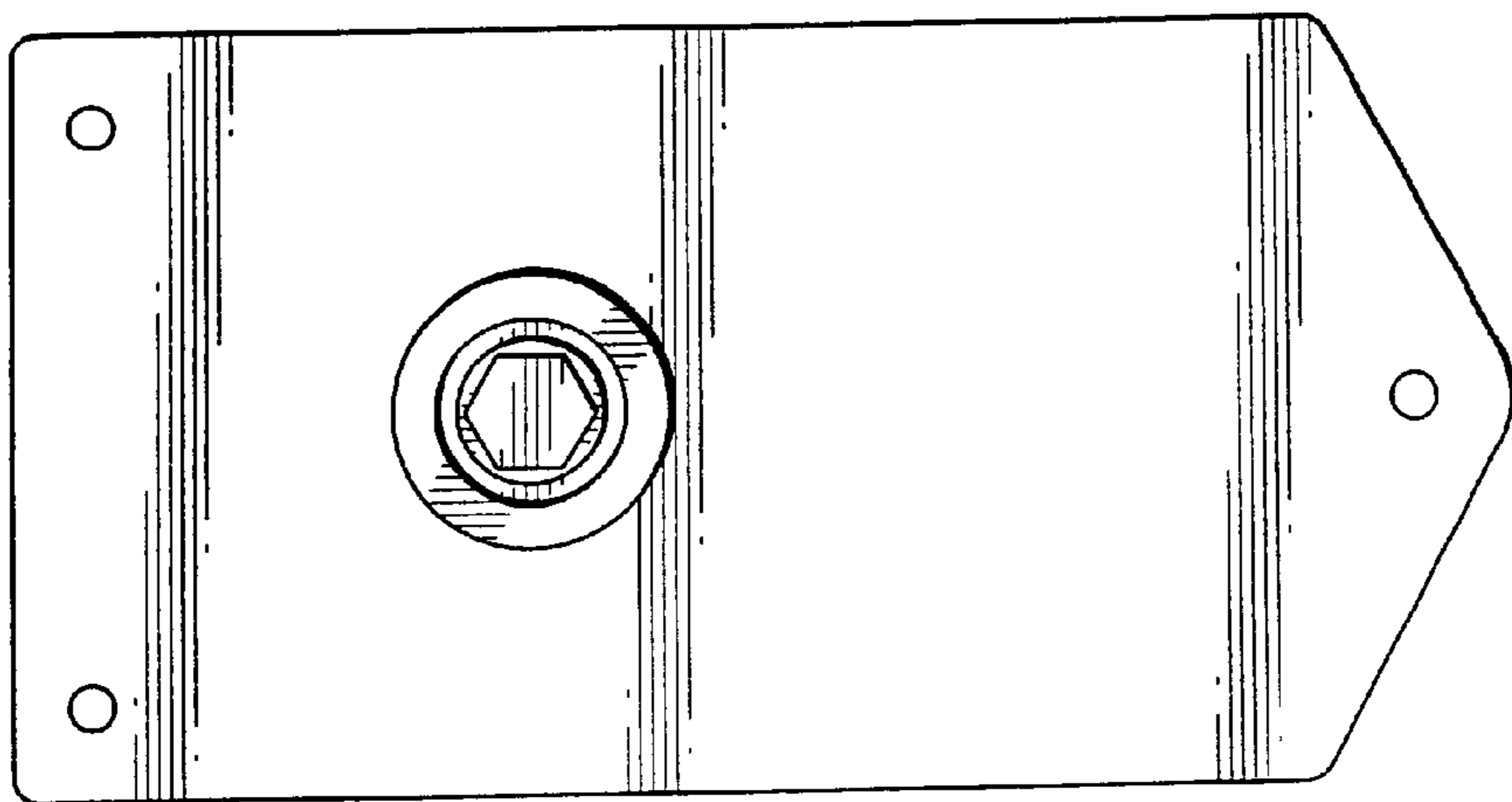

FIG. 3

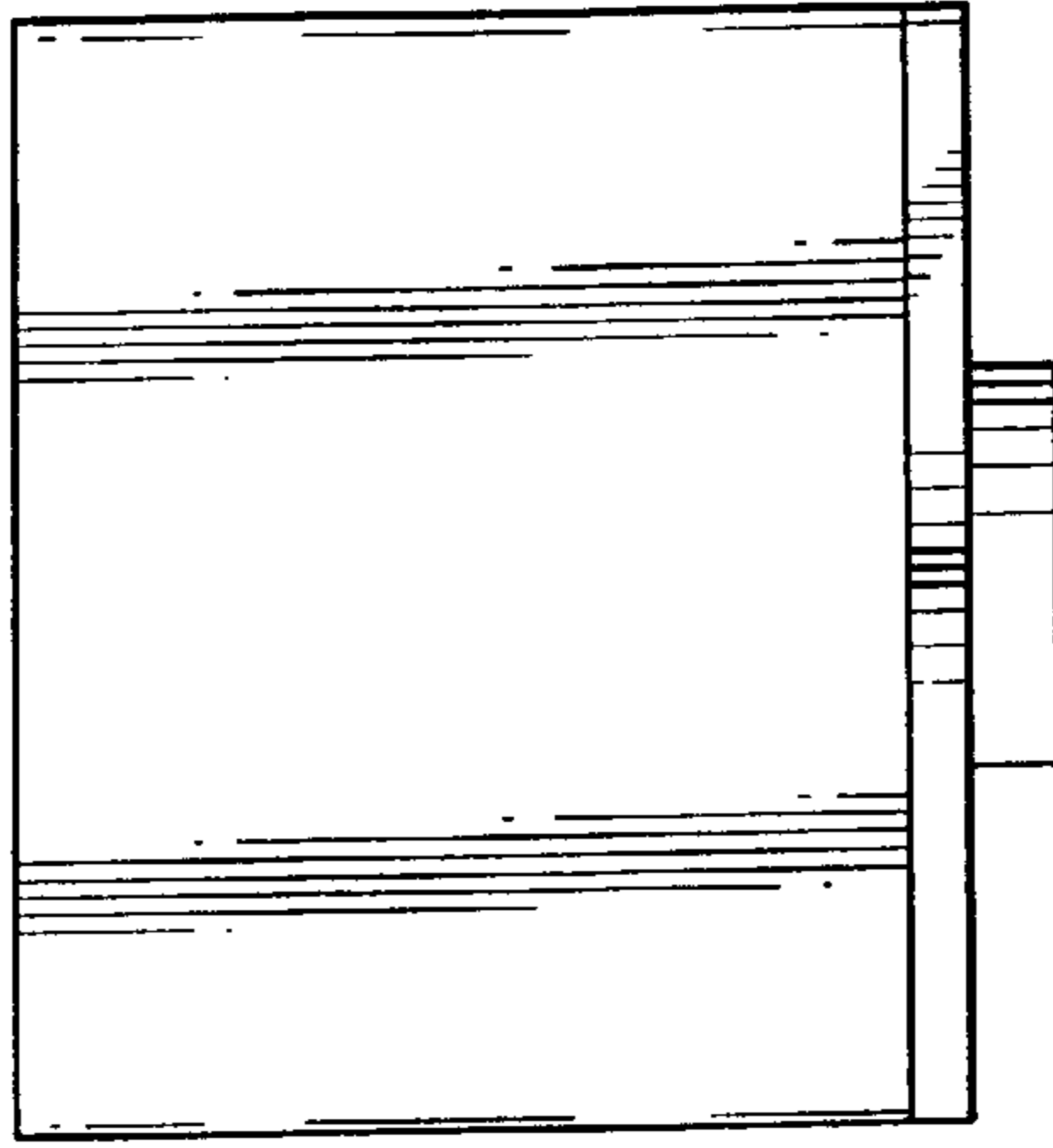

FIG. 4

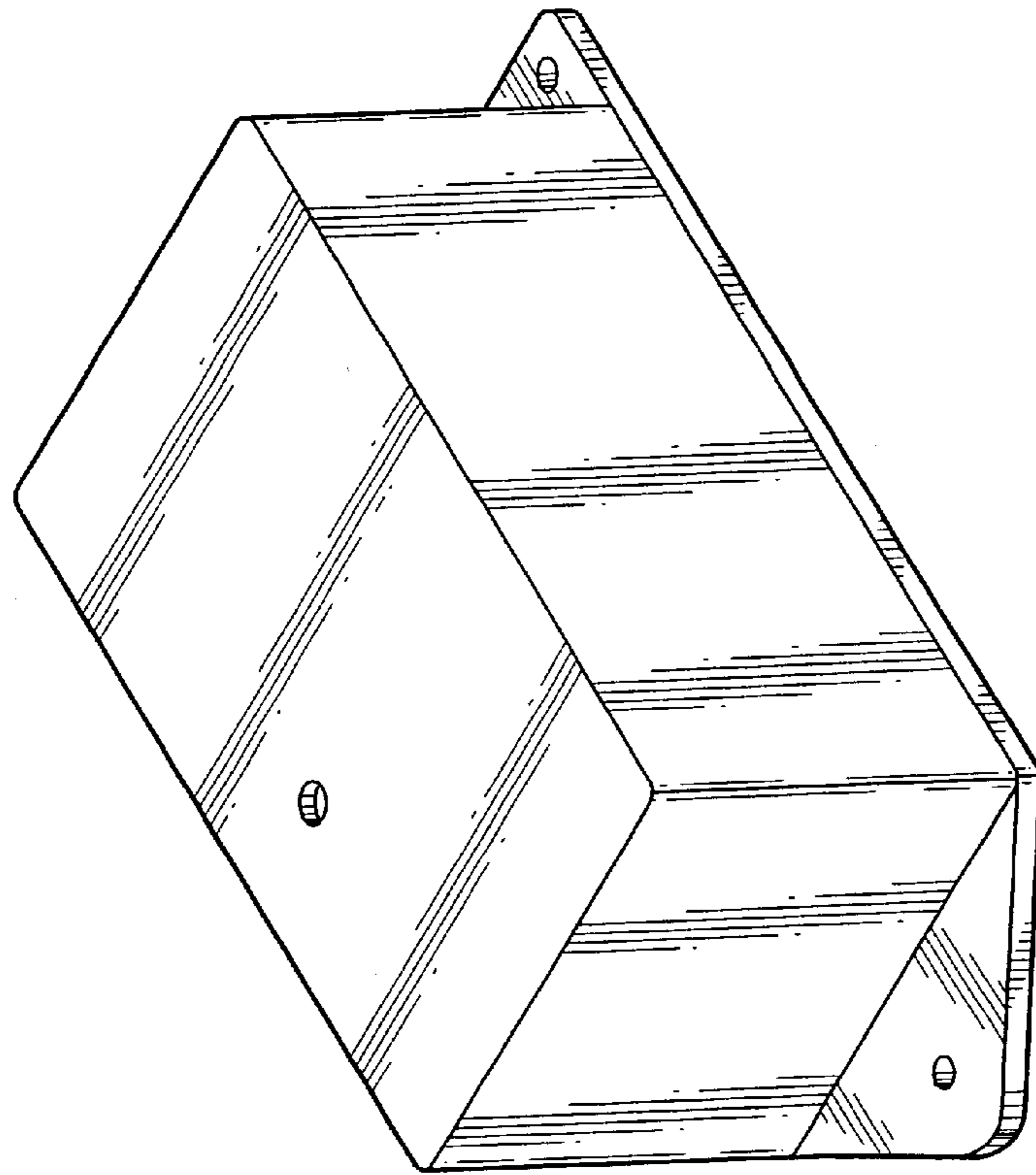

FIG. 6

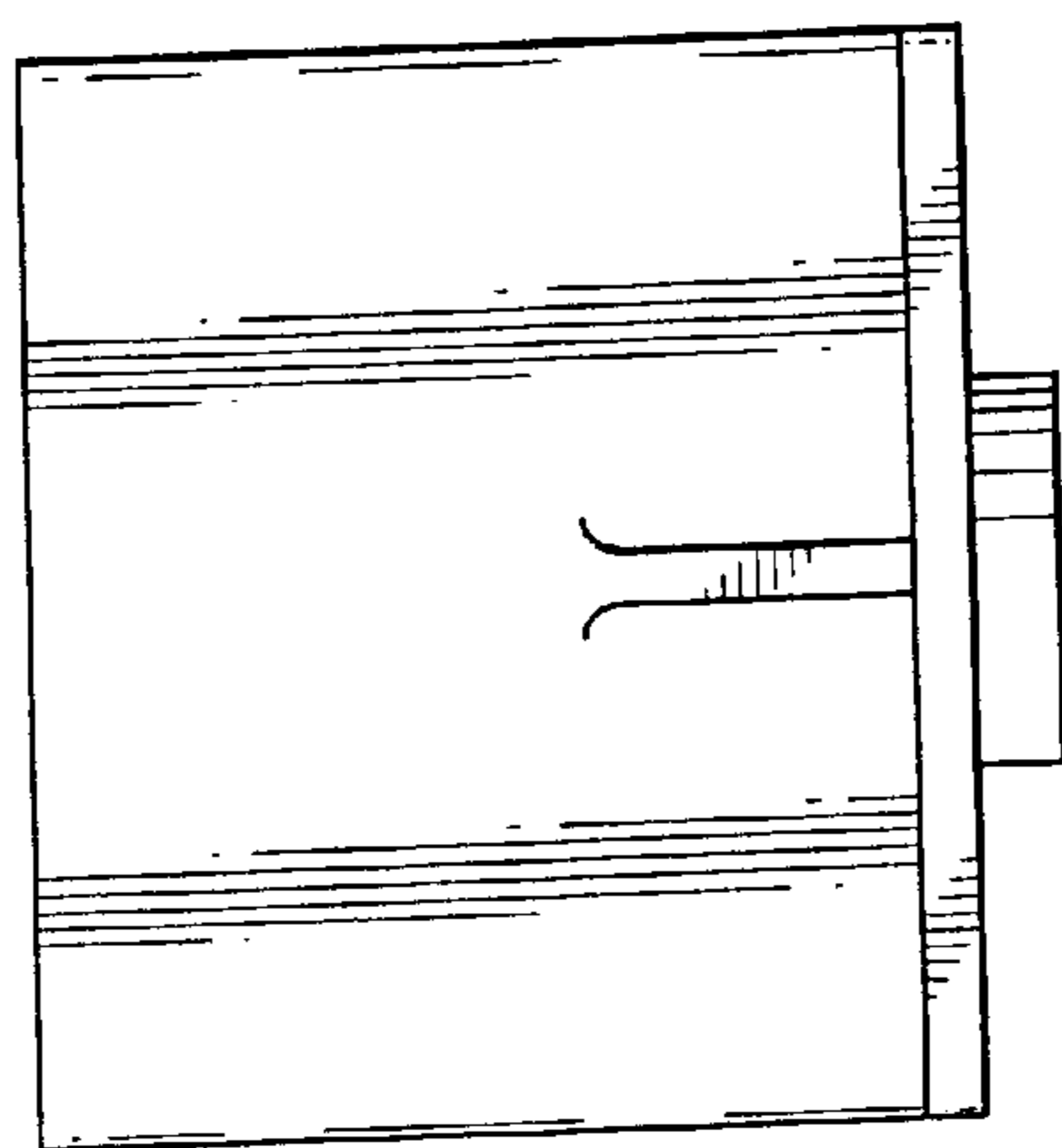

FIG. 5