



US00D490350S

(12) **United States Design Patent**  
**Blaschke et al.**

(10) **Patent No.:** **US D490,350 S**

(45) **Date of Patent:** **\*\* May 25, 2004**

(54) **ANCHOR BRACKET FOR A DISC BRAKE**

6,386,335 B1 \* 5/2002 DiPonio ..... 188/3.31

(75) Inventors: **Peter Blaschke**, Commerce, MI (US);  
**Lixin Zhang**, Windsor (CA); **Mingan Tan**, Windsor (CA)

\* cited by examiner

*Primary Examiner*—Lisa Lichtenstein

(74) *Attorney, Agent, or Firm*—Leo H. McCormick, Jr.;  
Warren Comstock

(73) Assignee: **Robert Bosch Corporation**,  
Broadview, IL (US)

(57) **CLAIM**

(\*\*) Term: **14 Years**

The ornamental design for an anchor bracket for a disc brake, as shown and described.

(21) Appl. No.: **29/181,591**

**DESCRIPTION**

(22) Filed: **May 13, 2003**

(51) **LOC (7) Cl.** ..... **12-16**

(52) **U.S. Cl.** ..... **D12/180**

(58) **Field of Search** ..... D12/180; 188/73.31,  
188/250 B, 250 D, 370, 73.35–73.39, 73.1,  
73.2, 73.41–73.46, 250 E

FIG. 1 is a perspective view of an anchor bracket for a disc brake showing our new design;

FIG. 2 is a top view of FIG. 1;

FIG. 3 is a front plan view of the anchor bracket for a disc brake of FIG. 2;

FIG. 4 is a bottom view of FIG. 2;

FIG. 5 is a side plan view of FIG. 2; and,

FIG. 6 is a rear plan view of FIG. 2.

(56) **References Cited**

**U.S. PATENT DOCUMENTS**

5,551,536 A \* 9/1996 Wang ..... 188/73.31

**1 Claim, 2 Drawing Sheets**

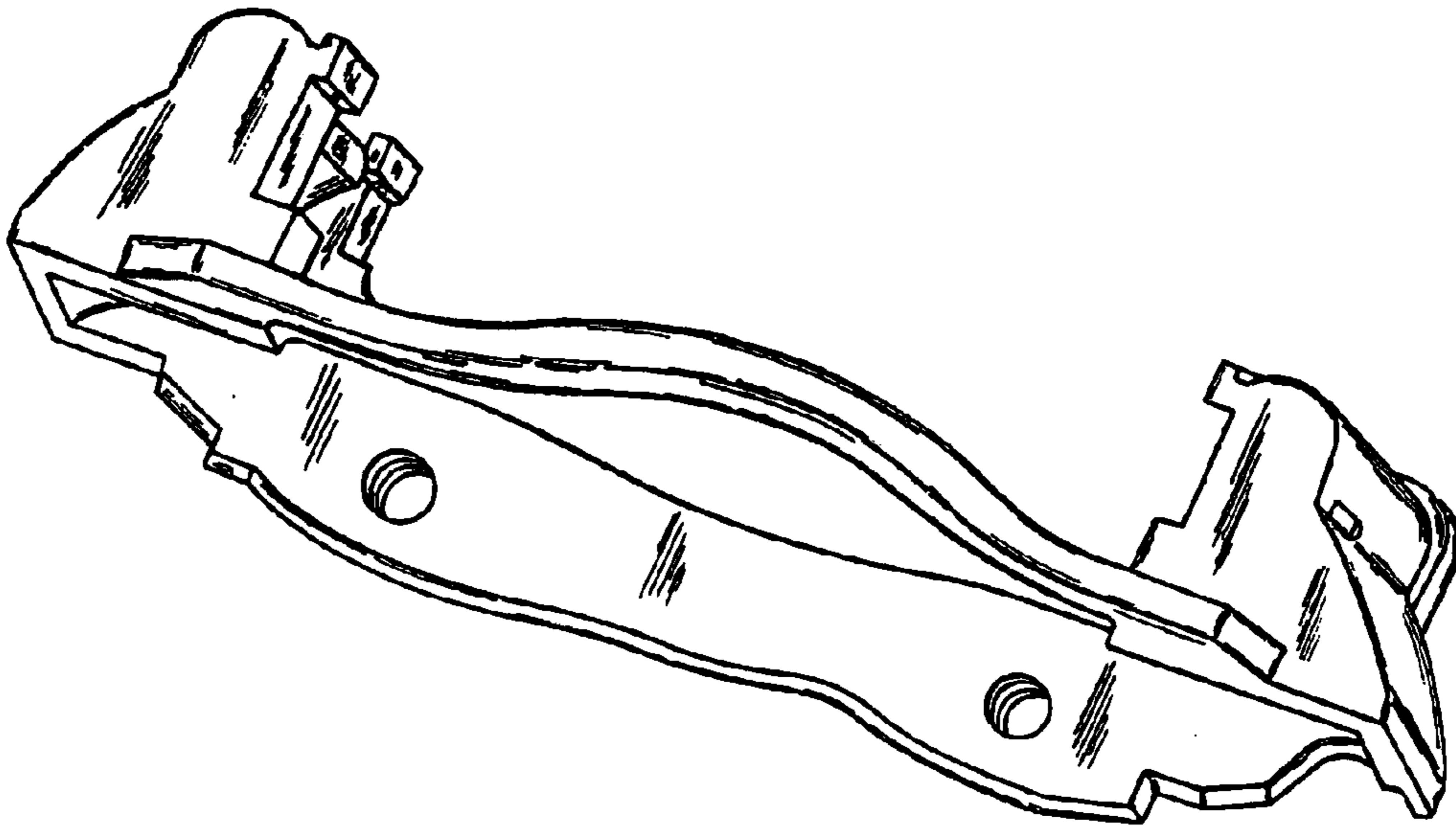

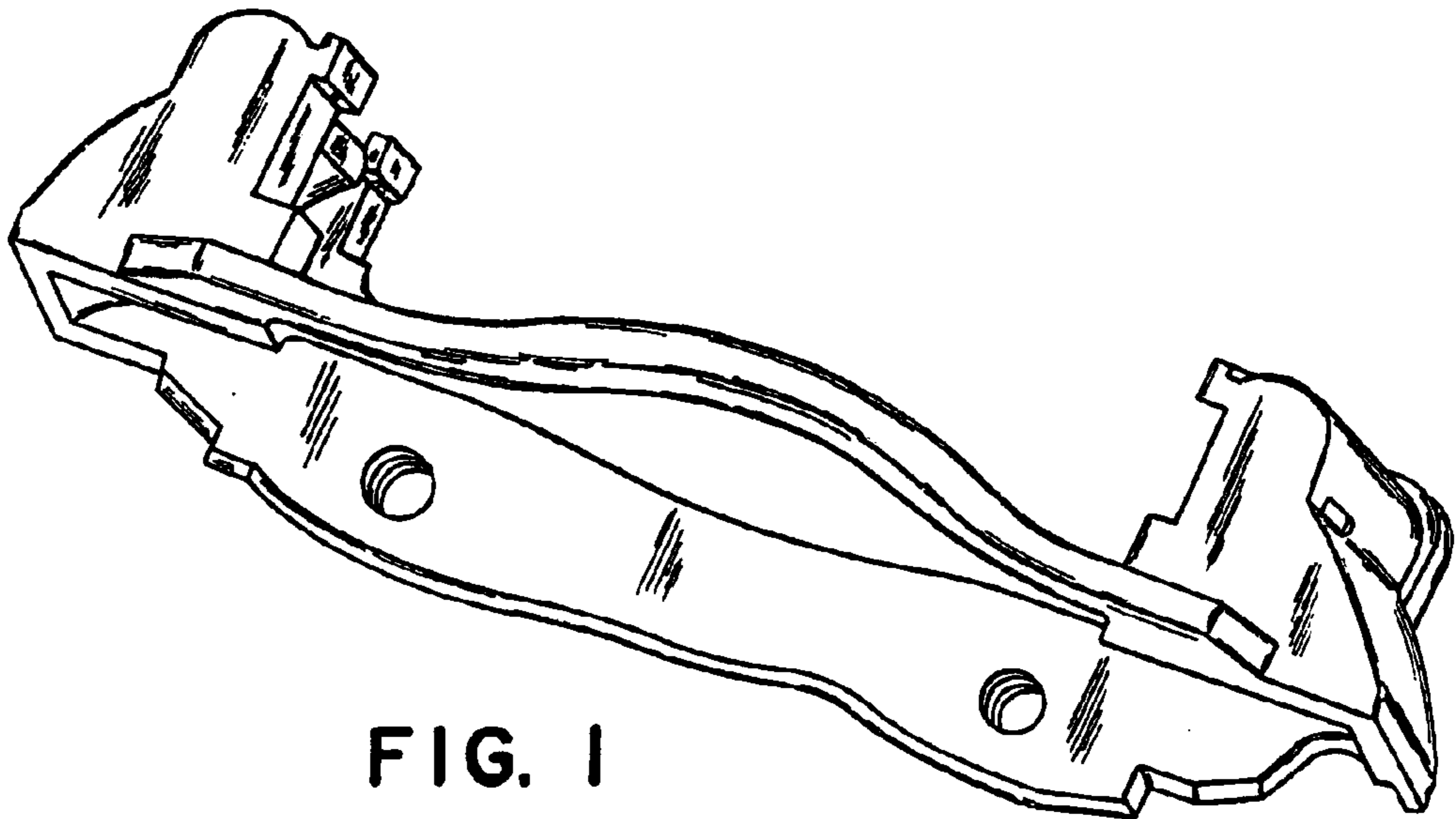

FIG. 1

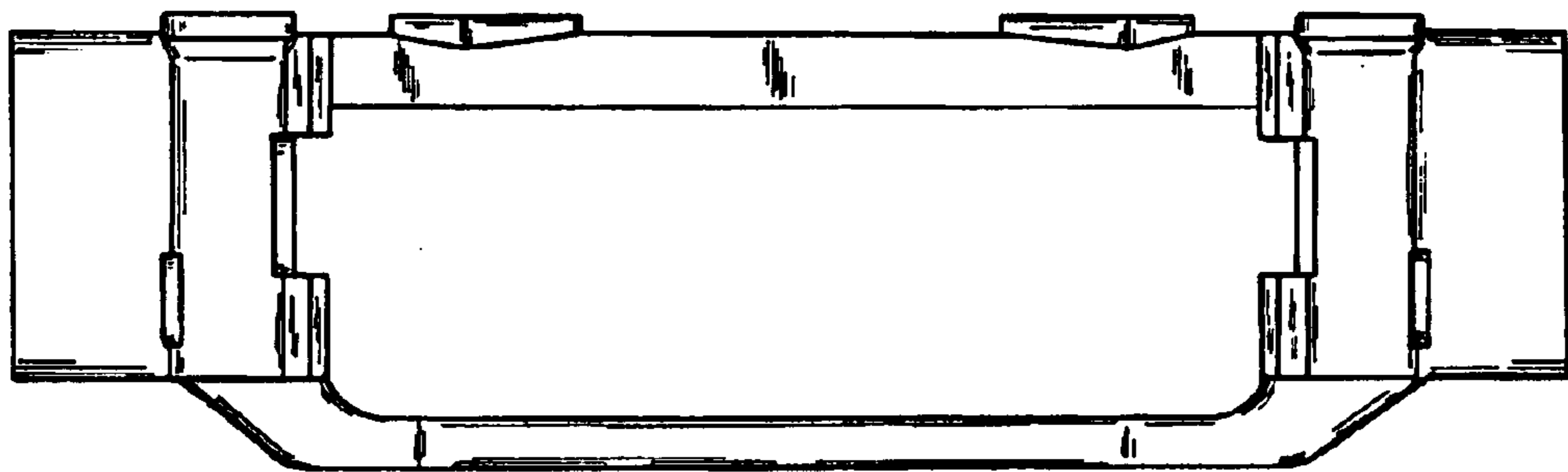

FIG. 2

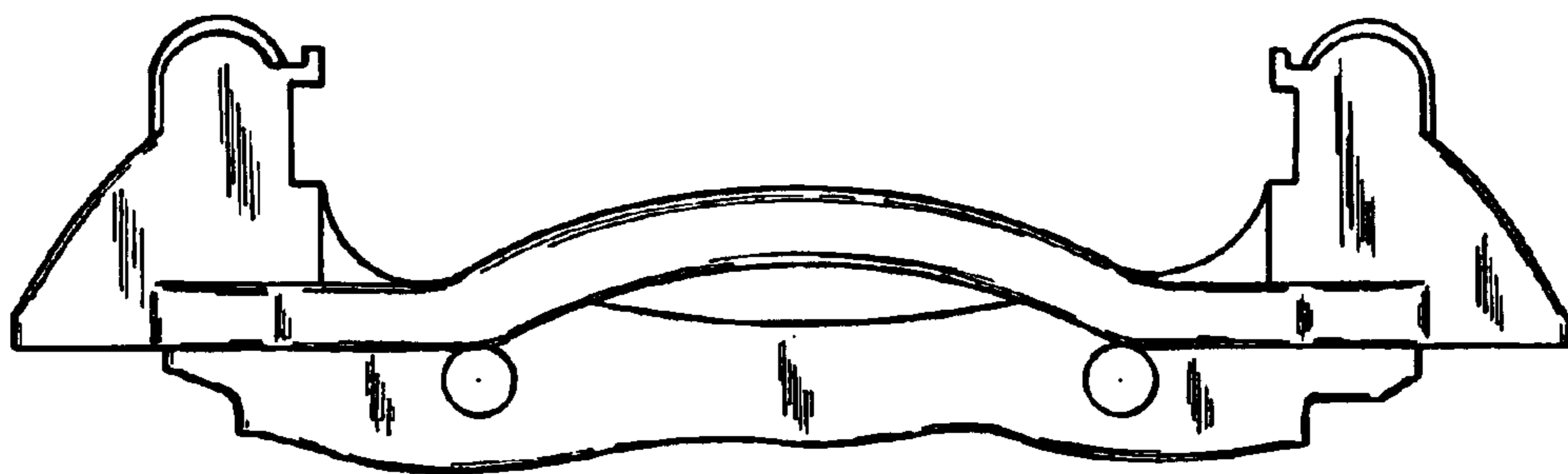
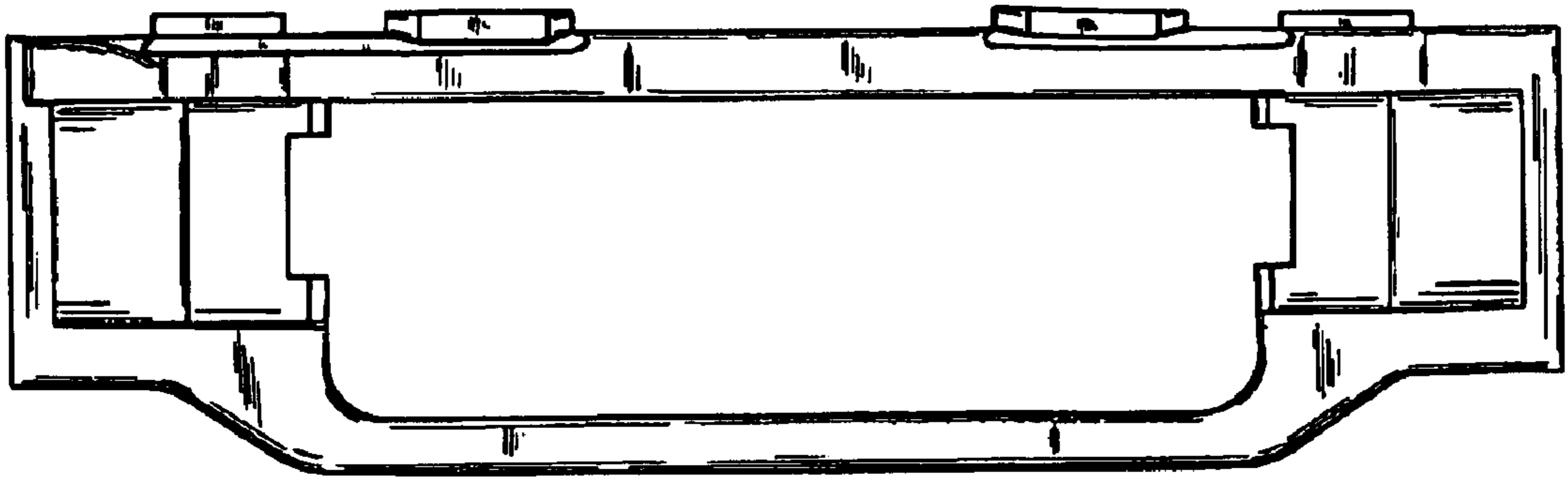
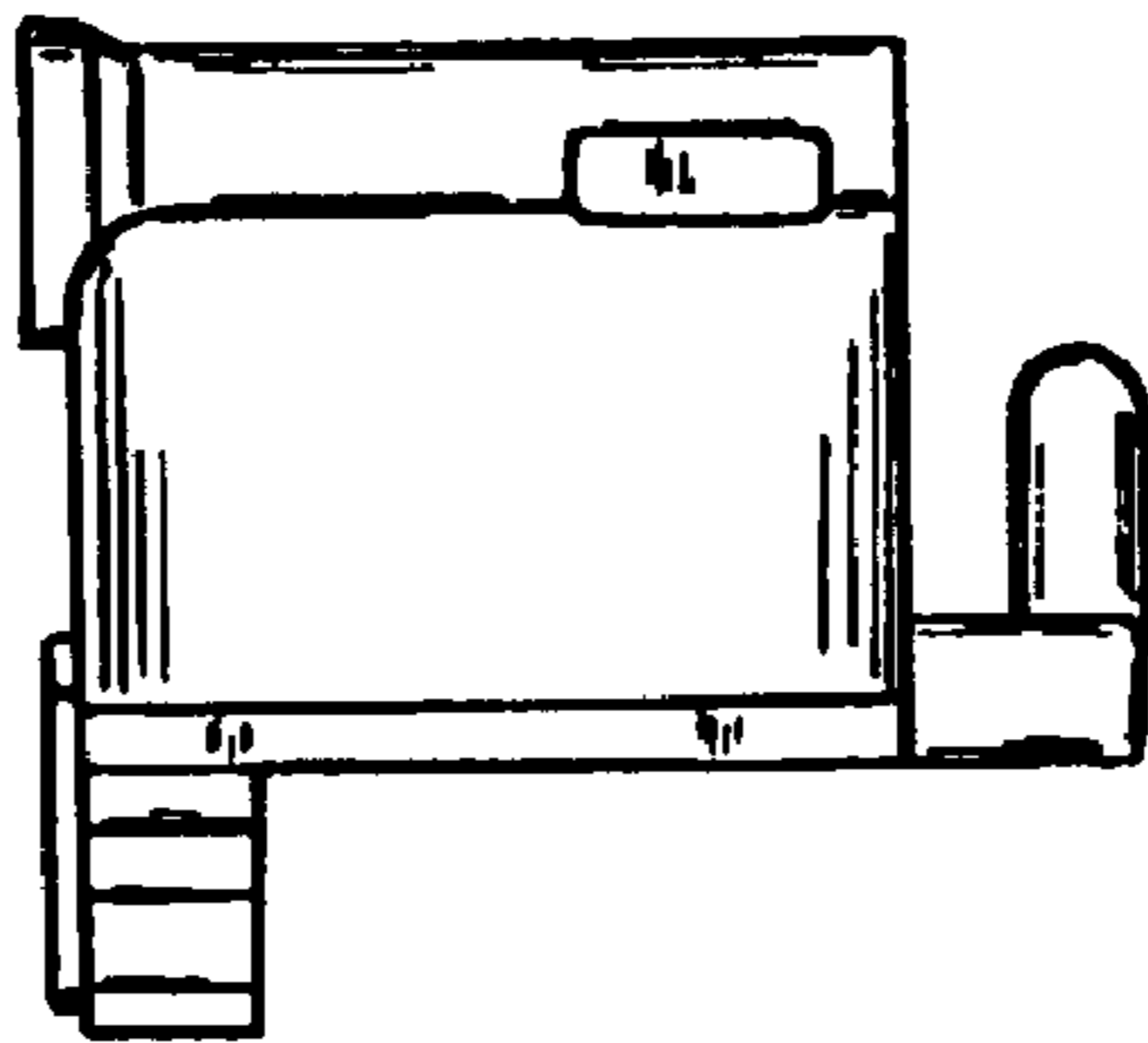

FIG. 3



**FIG. 4**



**FIG. 5**

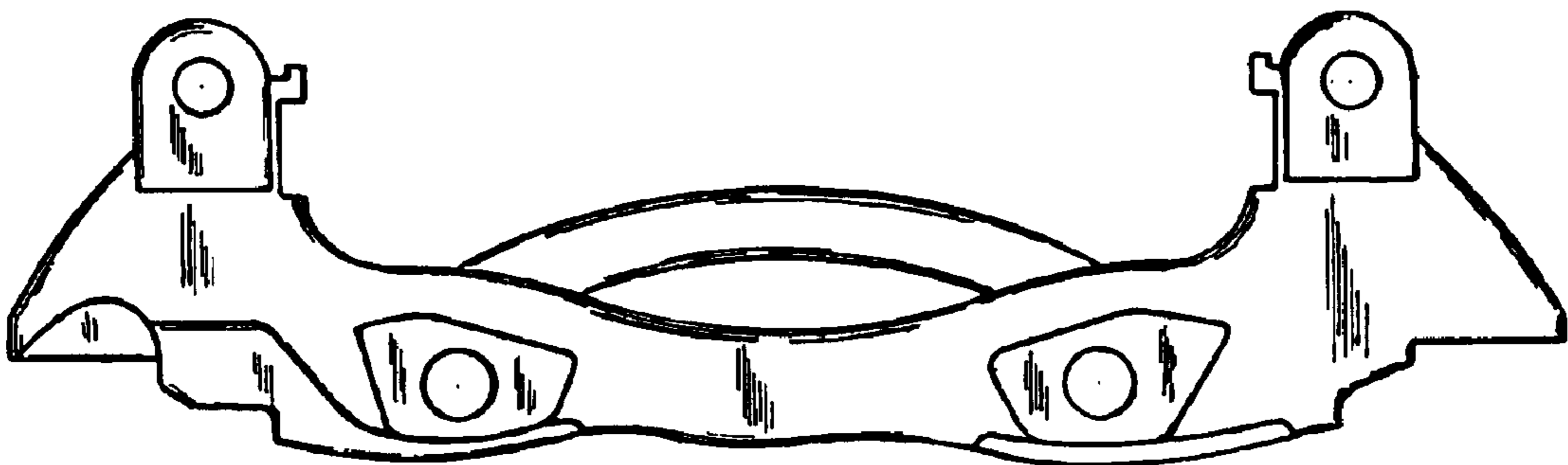

**FIG. 6**