



US00D490022S

(12) **United States Design Patent**
Sims et al.

(10) **Patent No.:** **US D490,022 S**

(45) **Date of Patent:** **** May 18, 2004**

(54) **AUTOMOBILE BODY**

(75) Inventors: **Daniel Sims**, Lake Forest, CA (US);
Michael Desmond, Long Beach, CA (US)

(73) Assignee: **Mitsubishi Jidosha Kogyo Kabushiki Kaisha**, Tokyo (JP)

(**) Term: **14 Years**

(21) Appl. No.: **29/179,854**

(22) Filed: **Apr. 16, 2003**

(51) **LOC (7) Cl.** **12-08**

(52) **U.S. Cl.** **D12/92**

(58) **Field of Search** D12/86, 90-92;
296/185

(56) **References Cited**

U.S. PATENT DOCUMENTS

D467,524 S	12/2002	Desmond	
D476,601 S	* 7/2003	Stoddard et al.	D12/92
D479,154 S	* 9/2003	Krugger et al.	D12/91
D479,492 S	* 9/2003	Gale et al.	D12/91
D483,696 S	* 12/2003	Howell et al.	D12/92

* cited by examiner

Primary Examiner—Melody N. Brown

(74) *Attorney, Agent, or Firm*—Birch, Stewart, Kolasch & Birch, LLP

(57) **CLAIM**

The ornamental design for an automobile body, as shown and described.

DESCRIPTION

FIG. 1 is a front perspective view of an automobile body constructed according to my novel design;

FIG. 2 is a front view thereof;

FIG. 3 is a rear elevational perspective view thereof;

FIG. 4 is a right side view thereof;

FIG. 5 is a top plan view thereof;

FIG. 6 is a rear view thereof;

FIG. 7 is a front perspective view of a second embodiment of an automobile body constructed according to my novel design;

FIG. 8 is a front view of the automobile body of FIG. 7;

FIG. 9 is a rear elevational perspective view of the automobile body of FIG. 7;

FIG. 10 is a right side view of the automobile body of FIG. 7;

FIG. 11 is a top plan view of the automobile body of FIG. 7; and,

FIG. 12 is a rear view of the automobile body of FIG. 7.

The broken lines showing of environmental structure in FIGS. 1-12 of the drawings are for illustrative purposes only and form no part of the claimed design.

1 Claim, 12 Drawing Sheets

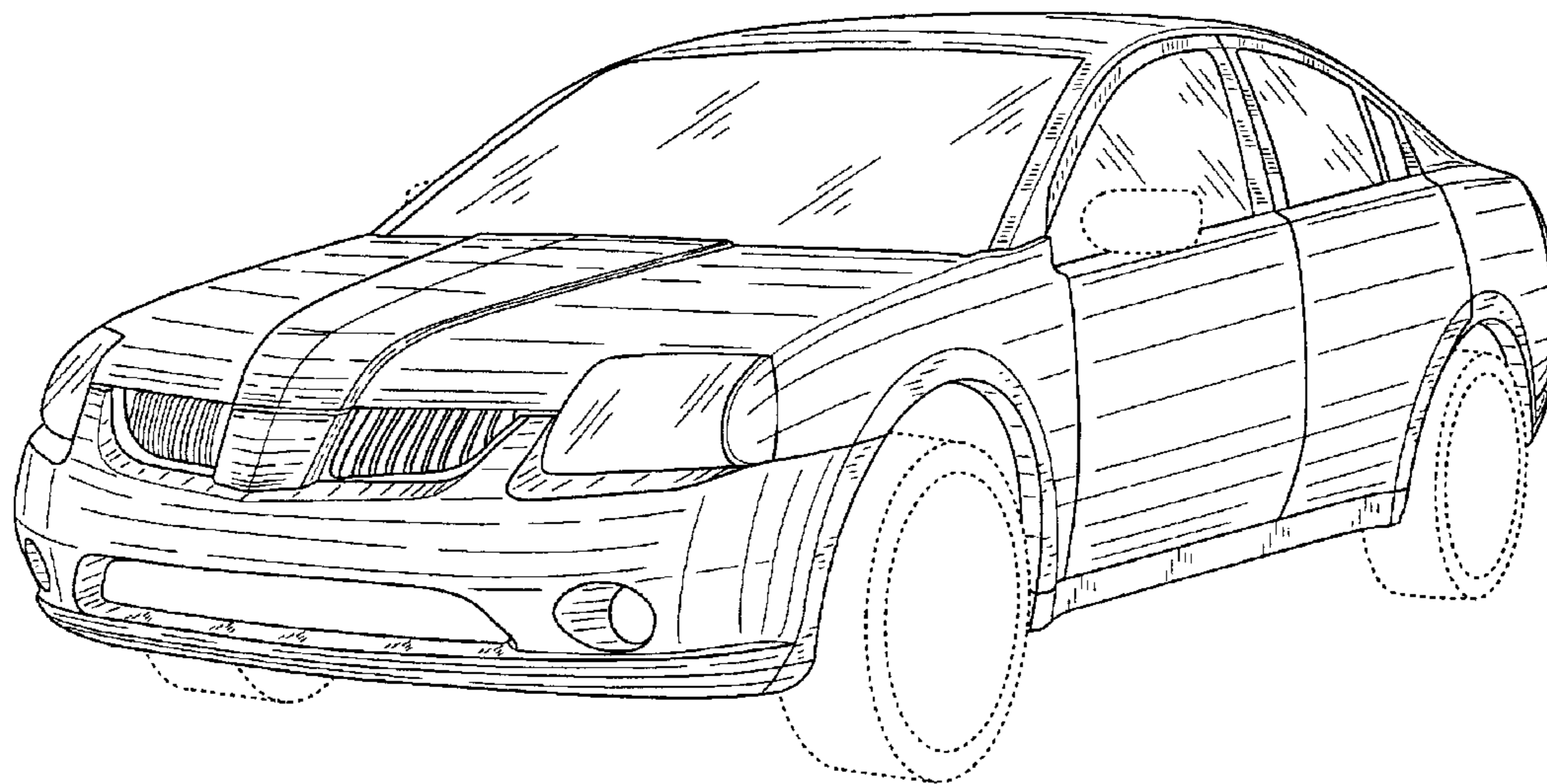

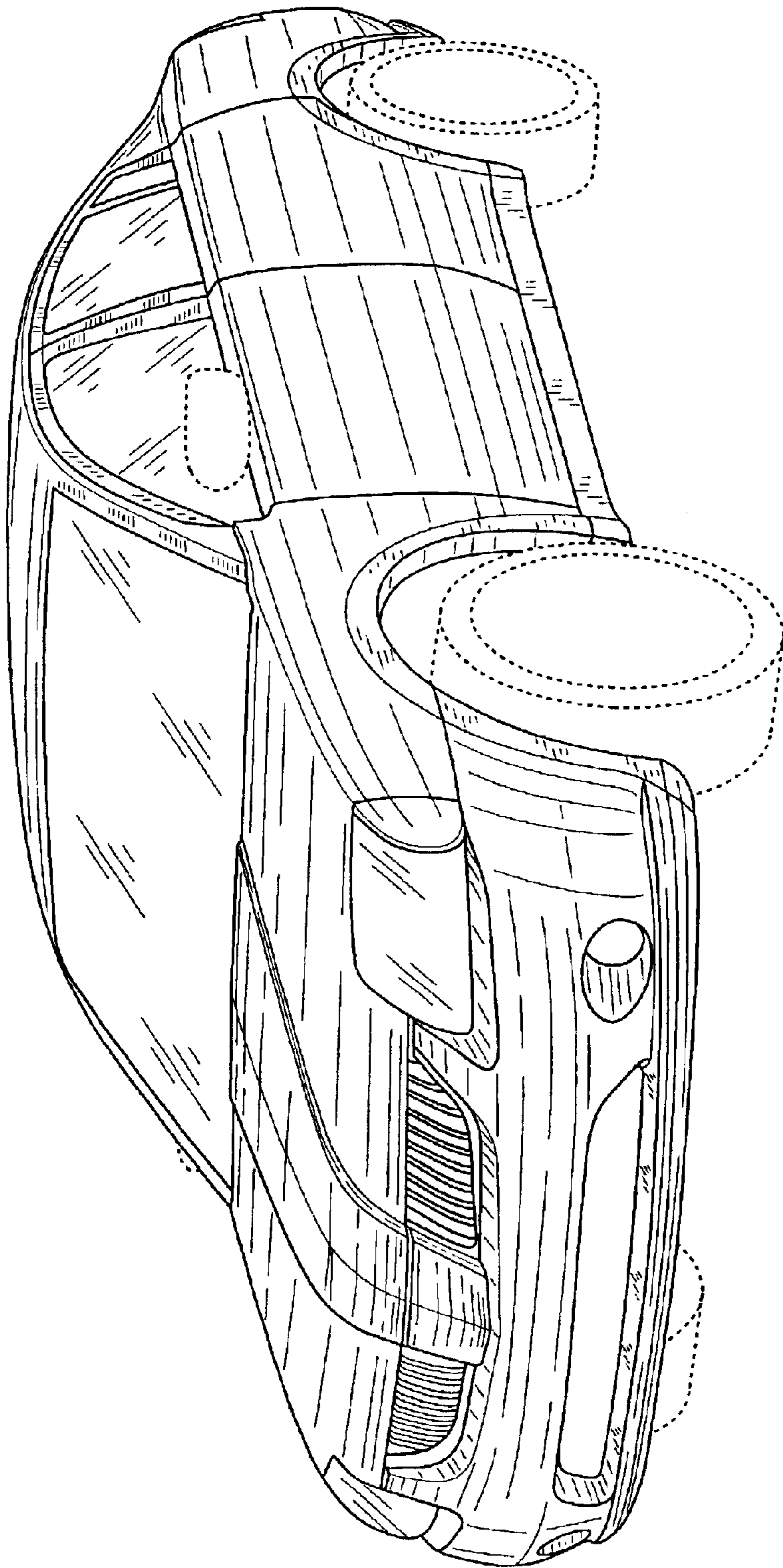

FIG. 1

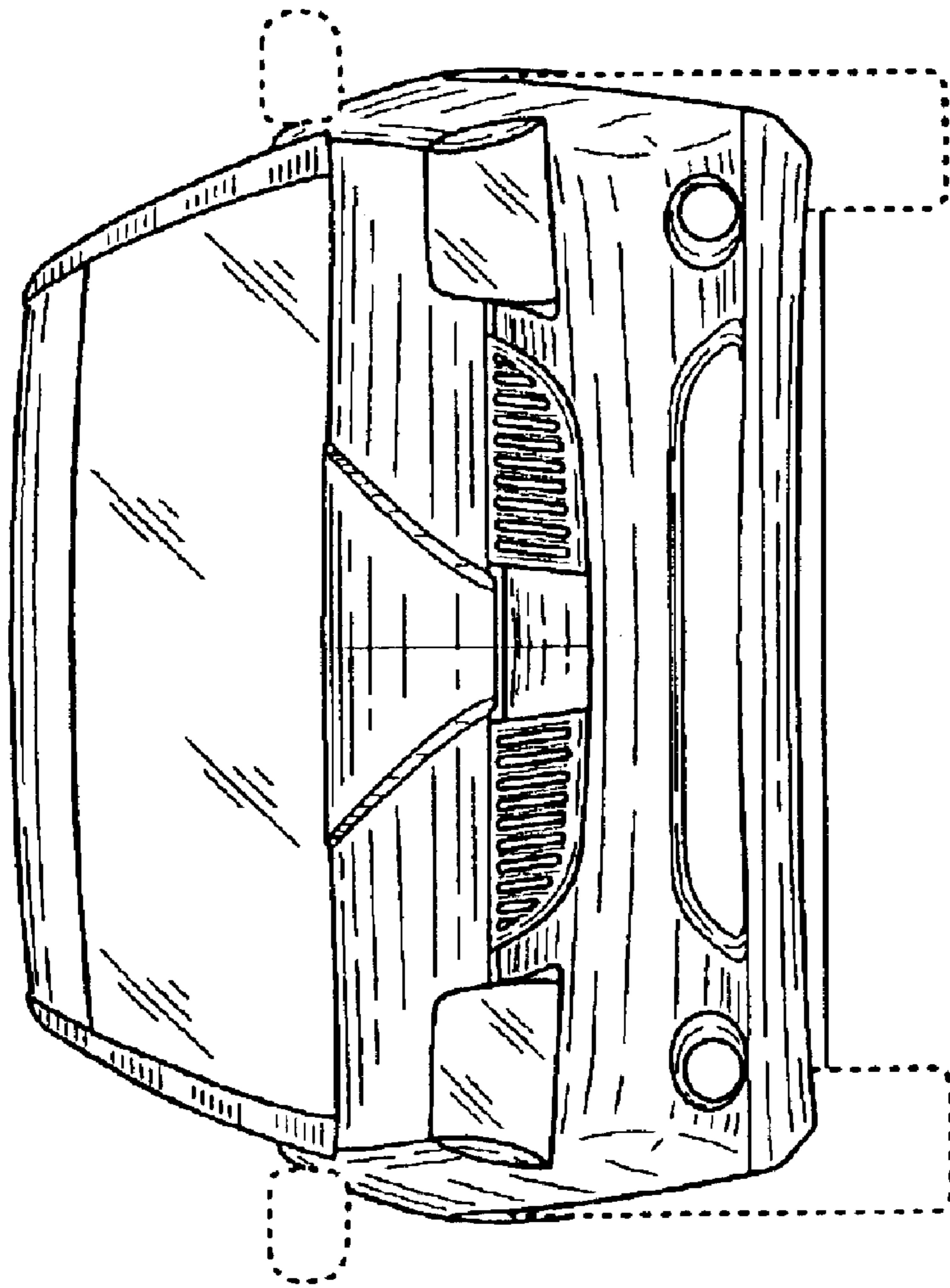

FIG. 2

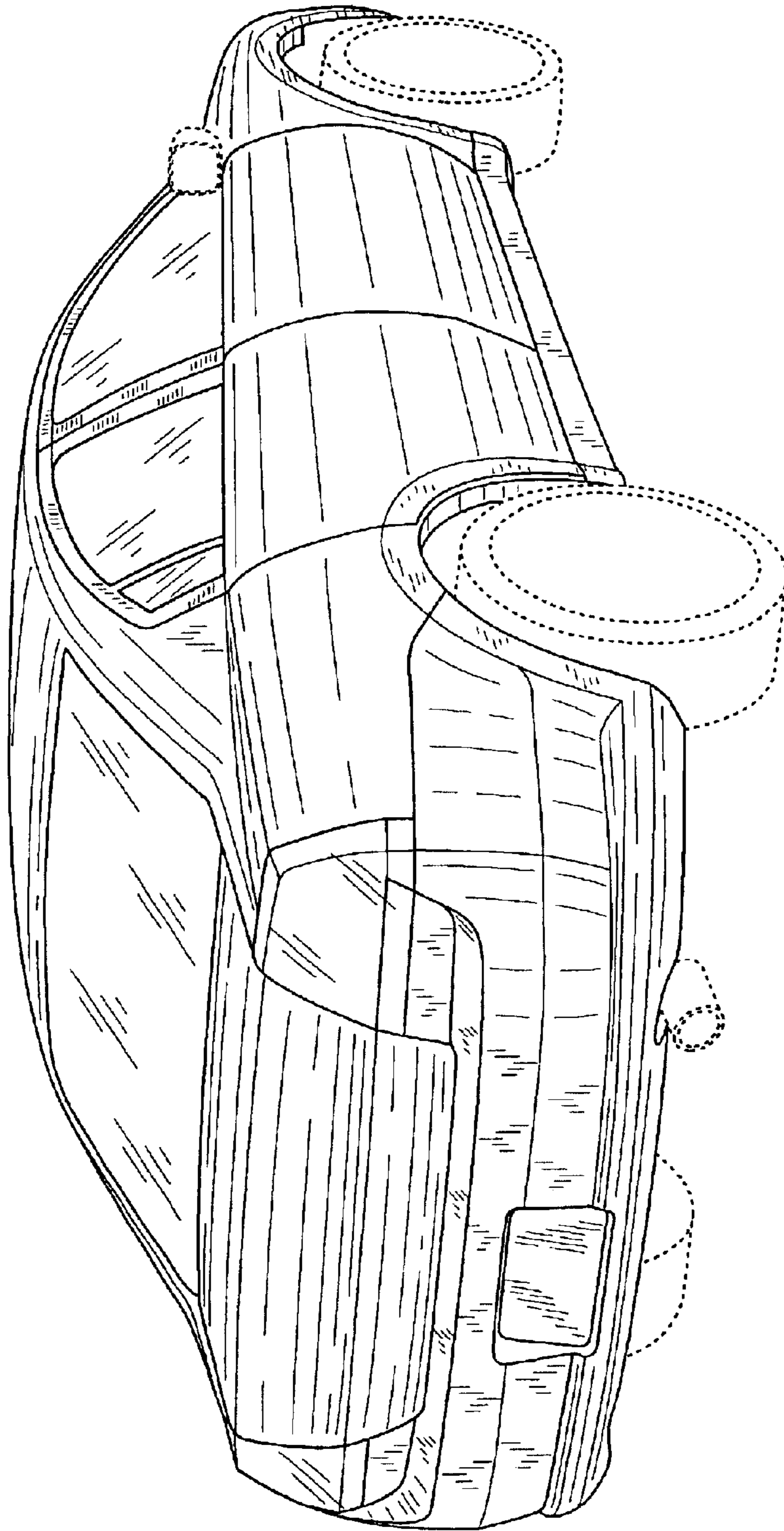

FIG. 3

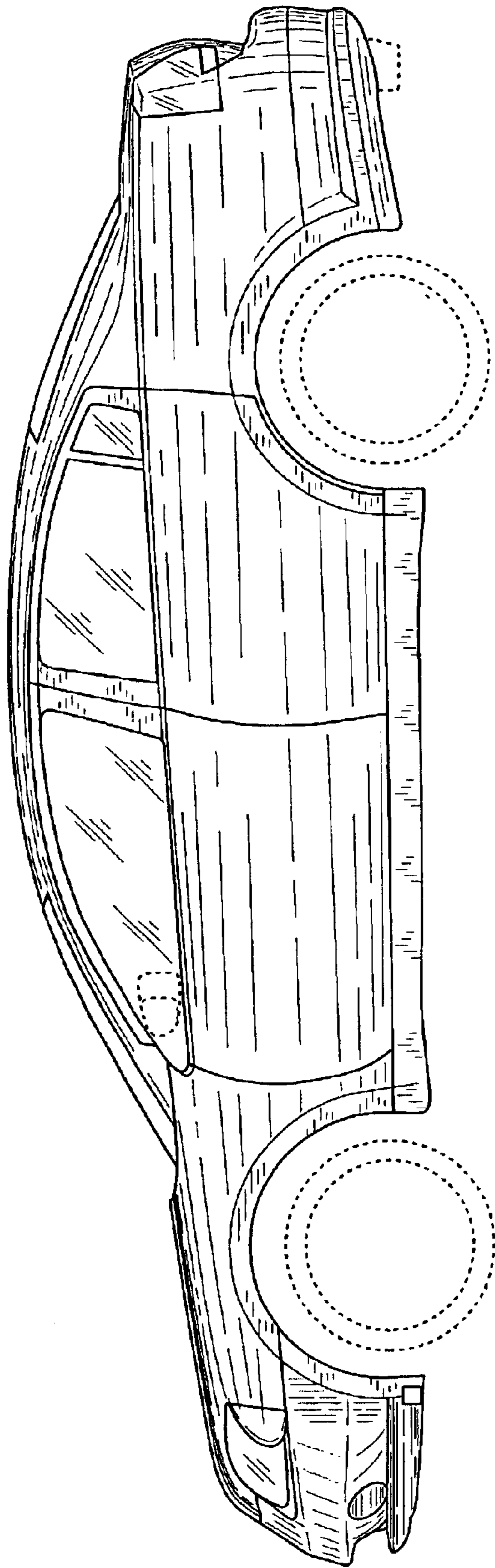

FIG. 4

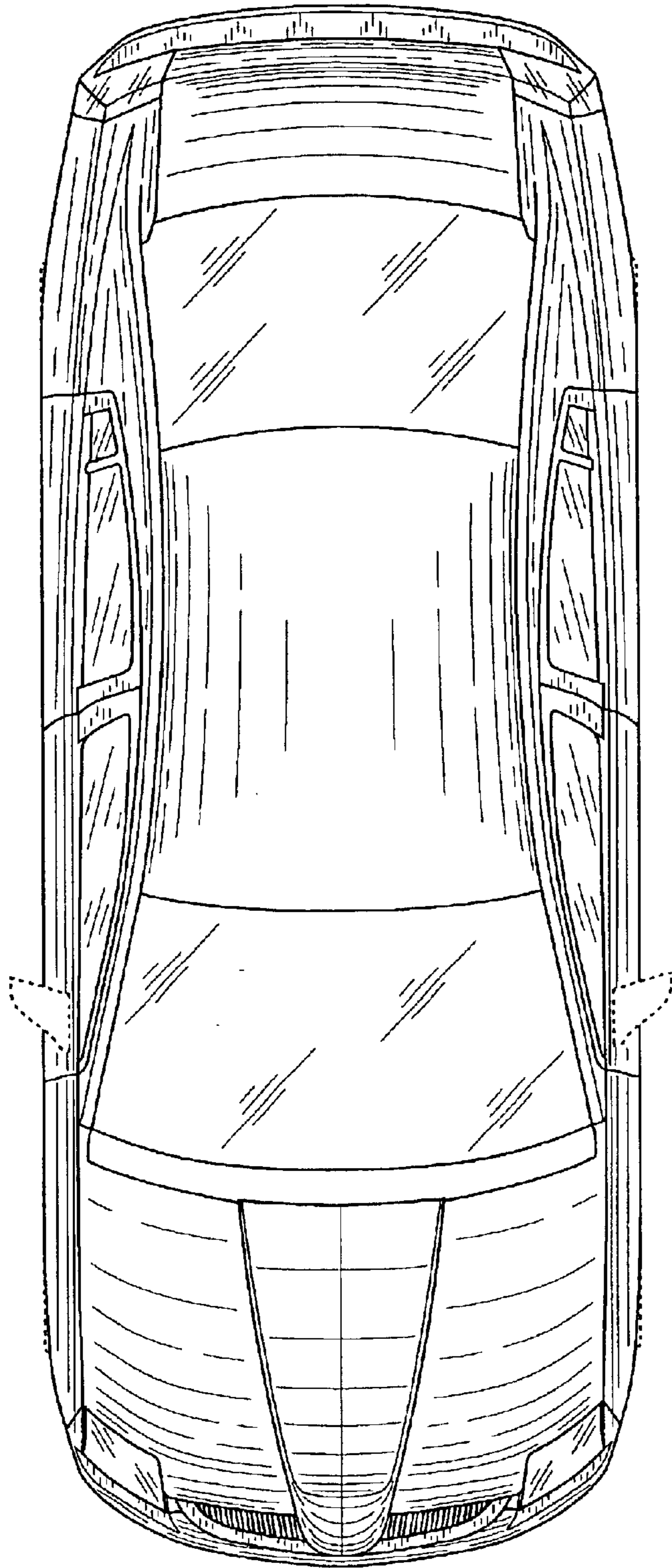

FIG. 5

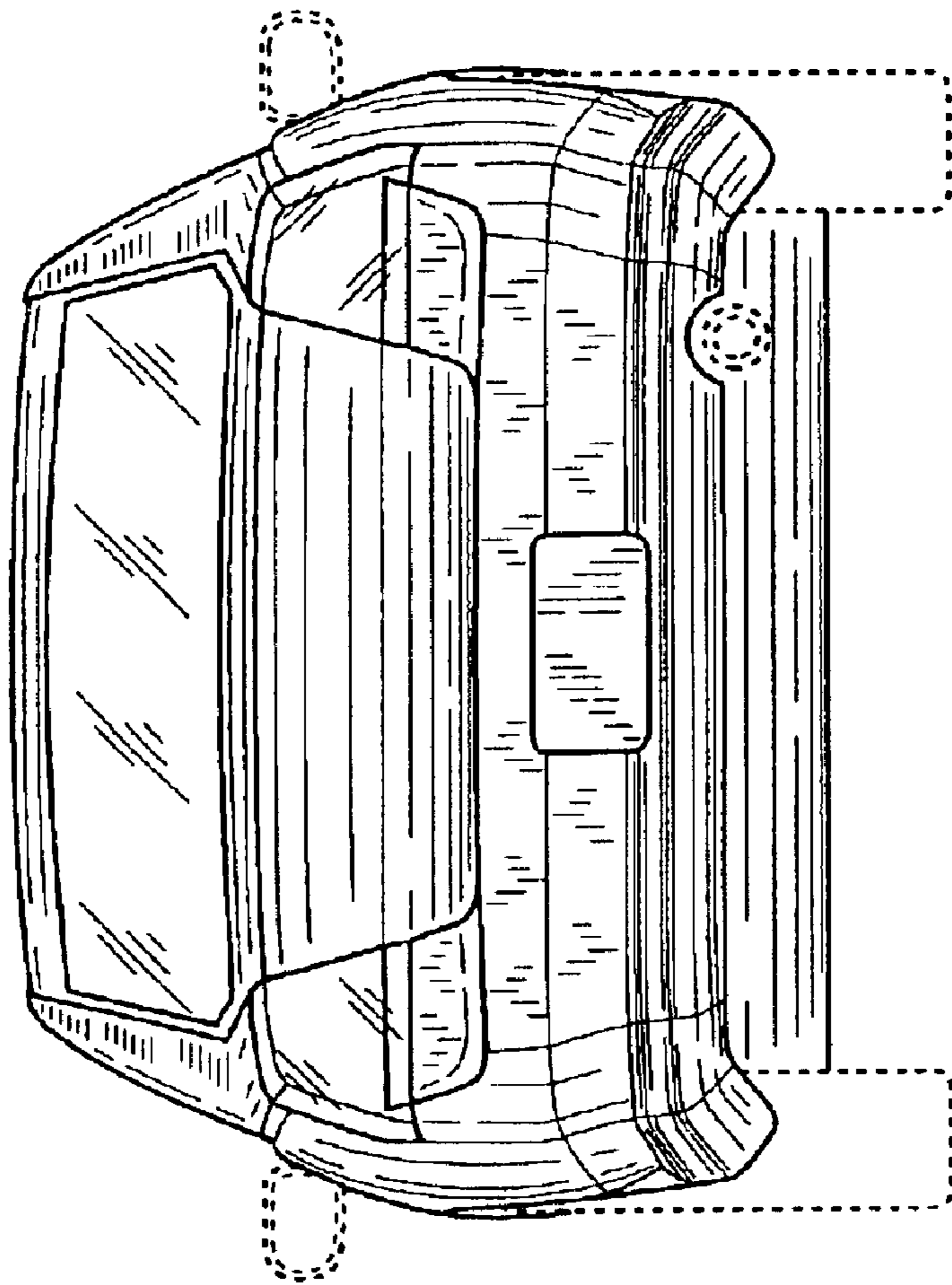

FIG. 6

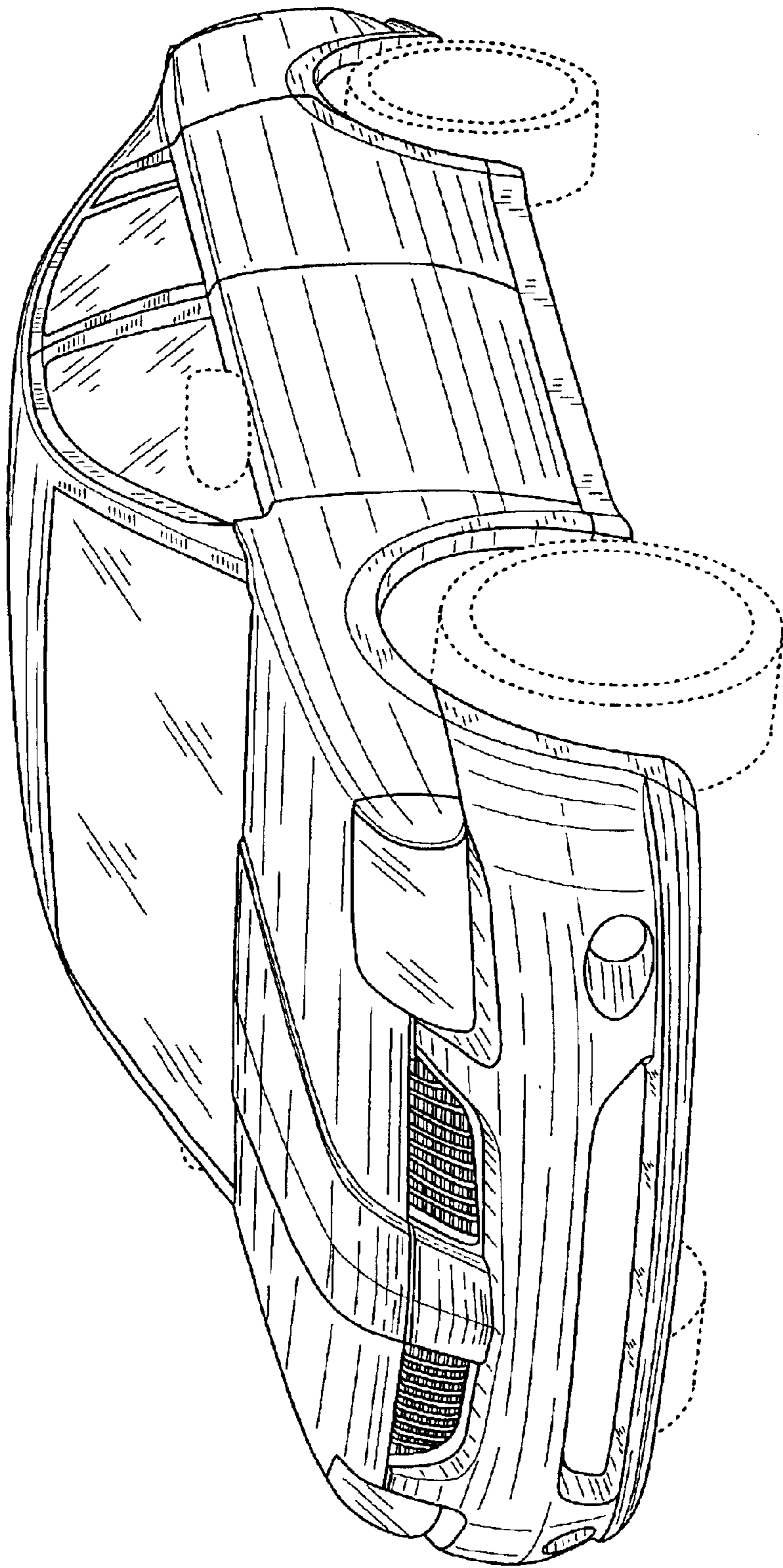

FIG. 7

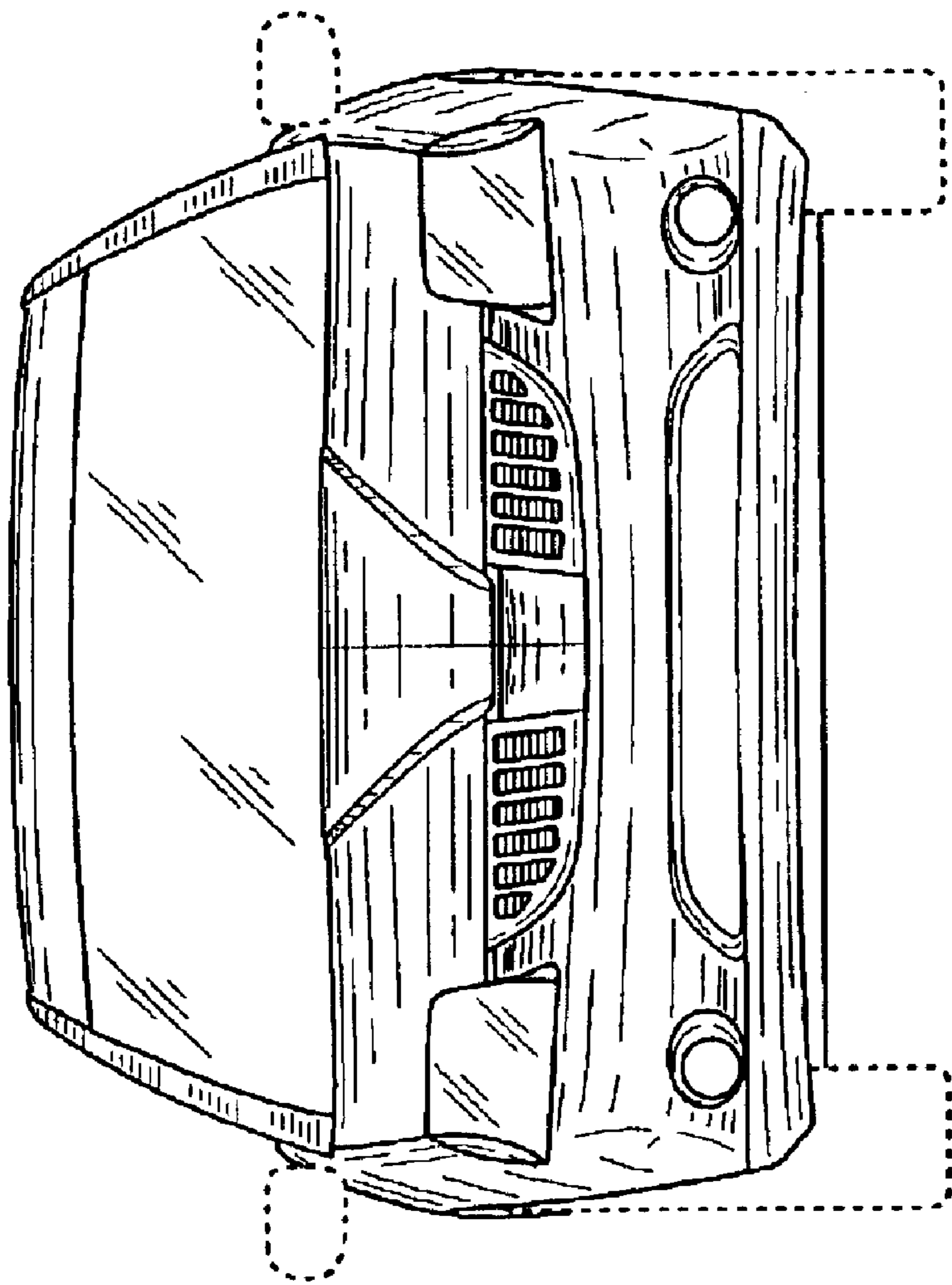

FIG. 8

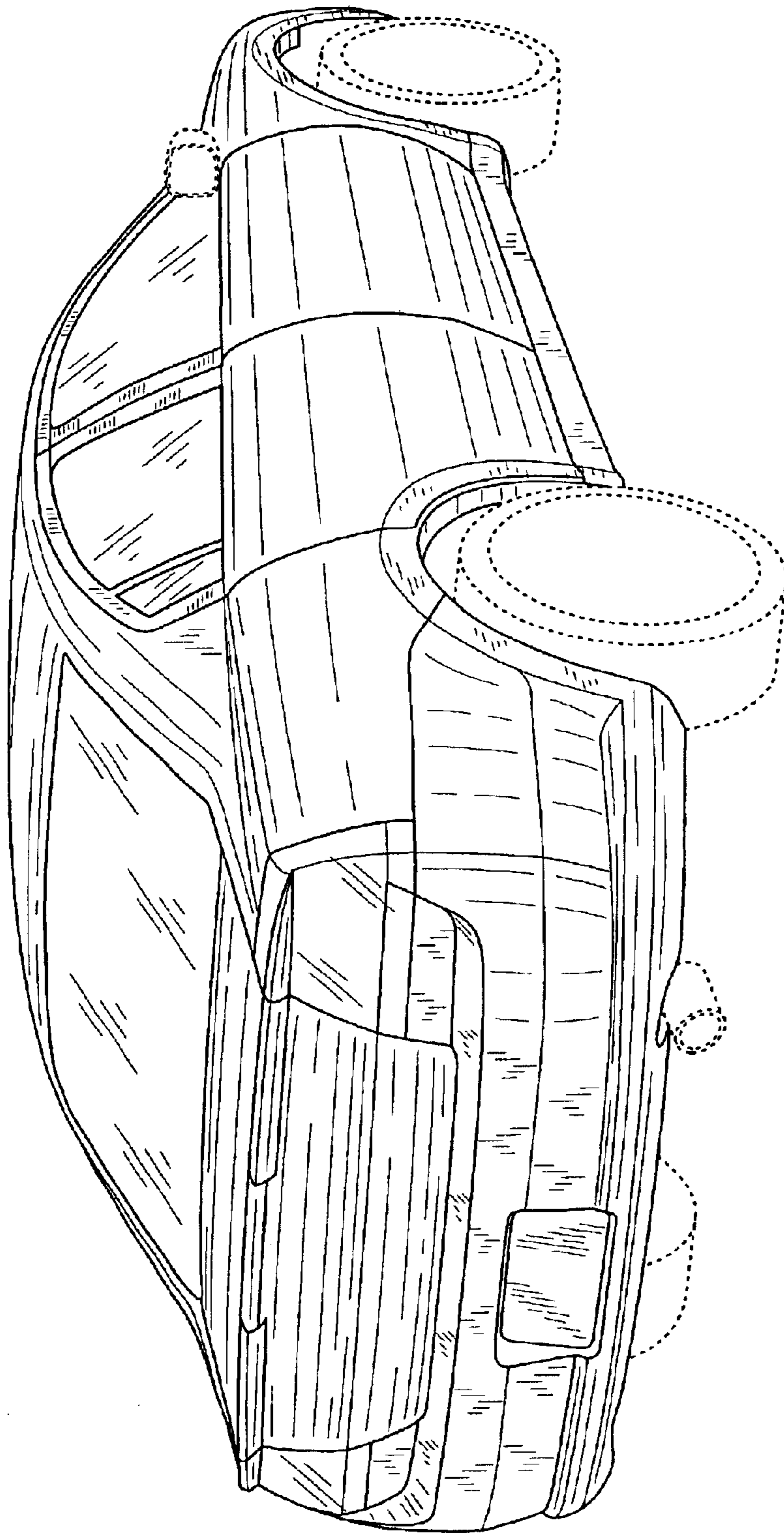

FIG. 9

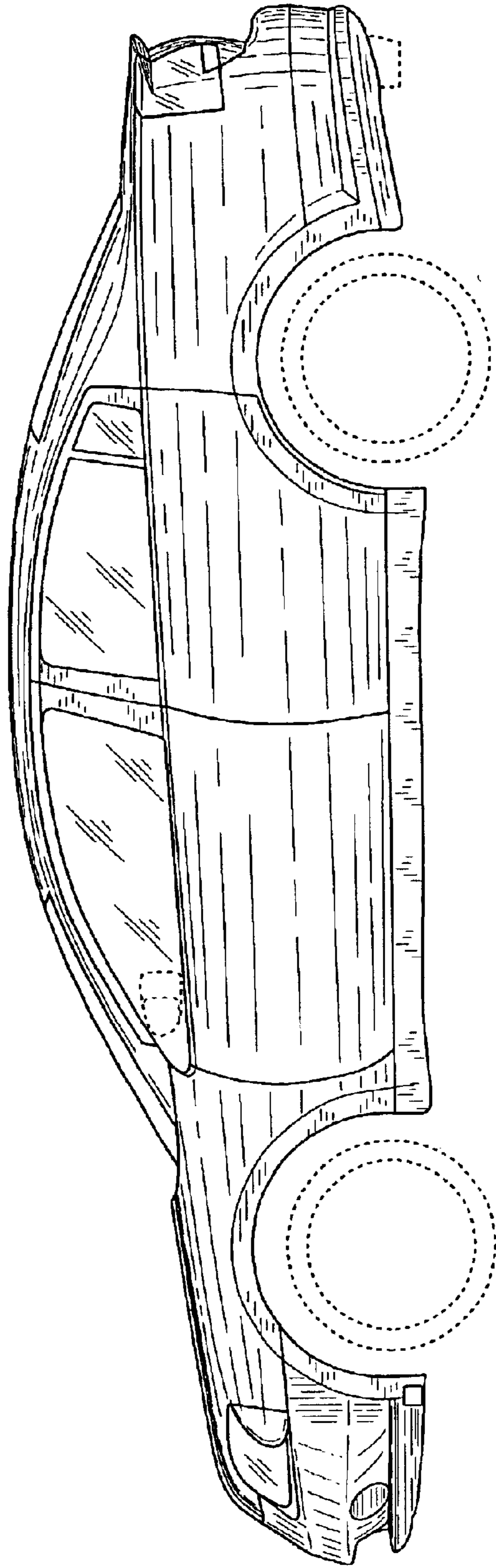

FIG. 10

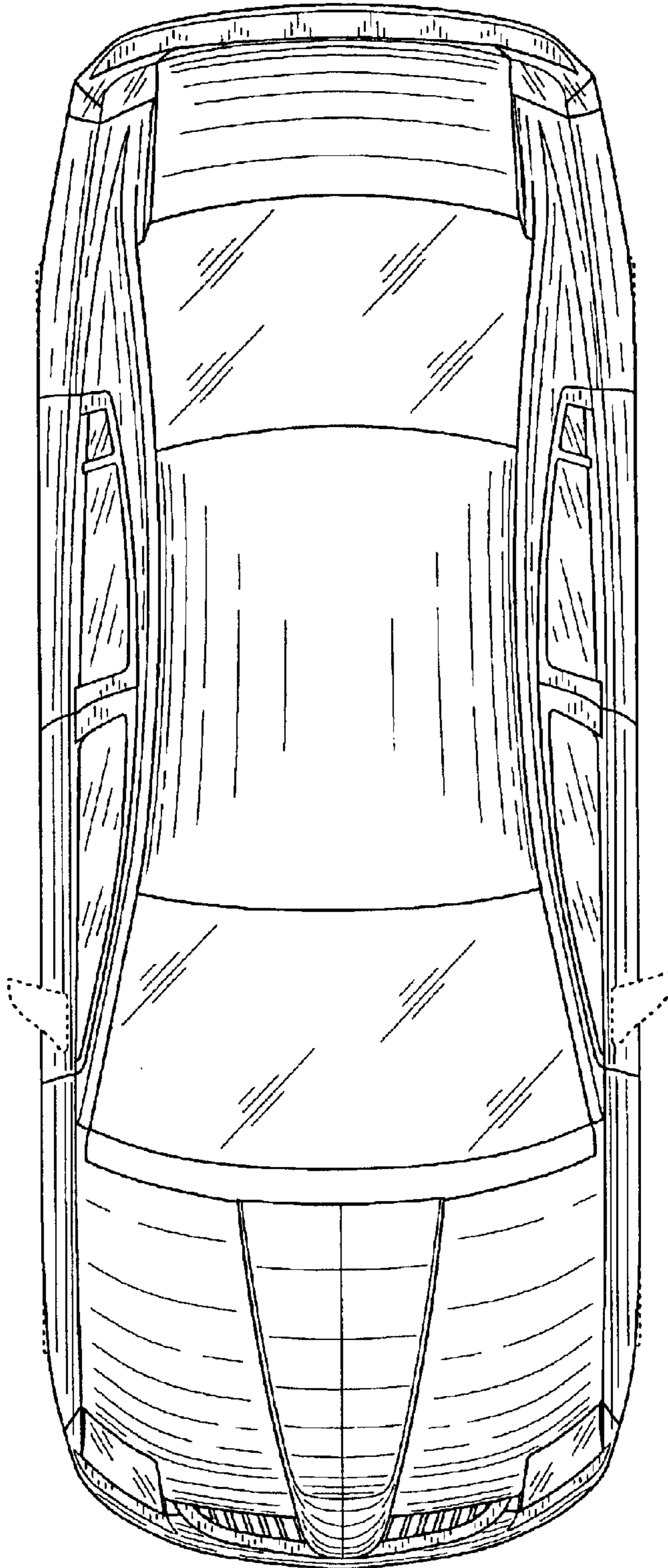

FIG. 11

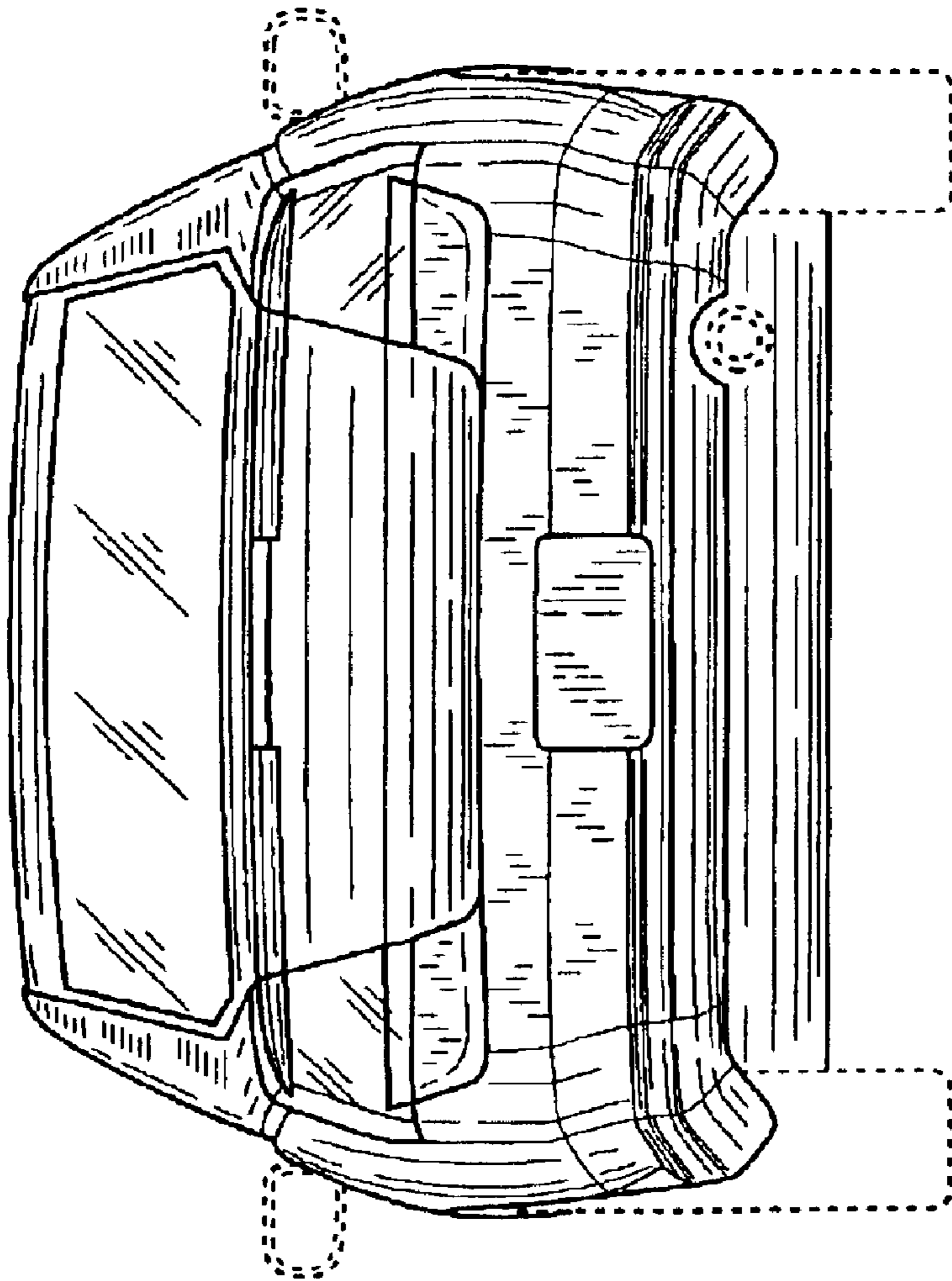

FIG. 12