



US00D489658S

(12) **United States Design Patent**  
**Metros et al.**

(10) **Patent No.:** **US D489,658 S**

(45) **Date of Patent:** **\*\* May 11, 2004**

(54) **VEHICLE SIDE VIEW MIRROR**

(75) Inventors: **Craig Metros**, Bloomfield, MI (US);  
**Patrick J. Schiavone**, Birmingham, MI (US);  
**Tyler Jon Blake**, Dearborn, MI (US);  
**Jeffery Nowak**, Huntington, MI (US)

(73) Assignee: **Ford Global Technologies, LLC**,  
Dearborn, MI (US)

(\*\*) Term: **14 Years**

(21) Appl. No.: **29/173,453**

(22) Filed: **Dec. 30, 2002**

**Related U.S. Application Data**

(63) Continuation-in-part of application No. 29/171,886, filed on  
Dec. 2, 2002.

(51) **LOC (7) Cl.** ..... **12-16**

(52) **U.S. Cl.** ..... **D12/187**

(58) **Field of Search** ..... D12/187-189;  
359/838-850, 855-868, 871-881

(56) **References Cited**

**U.S. PATENT DOCUMENTS**

D372,450 S	*	8/1996	Santo	.....	D12/187
D410,421 S	*	6/1999	Pfeiffer	.....	D12/187
D455,690 S	*	4/2002	Lee	.....	D12/187
D464,922 S	*	10/2002	Kuo	.....	D12/187
D478,853 S	*	8/2003	Boyer	.....	D12/187

**OTHER PUBLICATIONS**

Ford Motor Company; excerpts from product brochure  
entitled "1978 Ford Pickups".

Ford Motor Company; excerpts from product brochure  
entitled "'8 Ford Pickups. Tough All Over".

Ford Motor Company; excerpts from product entitled "Ford  
Truck Accessories and Specialties Catalog"; published  
1978.

Ford Motor Company; excerpts from product brochure  
entitled "Nuovo Ford Transit."; published circa 1978.

Ford Motor Company; excerpts from product brochure  
entitled "'78 Ford Courier".

Ford Motor Company; excerpts from product brochure  
entitled "Tough Ford pickups: America's No. 1 sellers.\*";  
published circa 1977.

Ford Motor Company; excerpts from product brochure  
entitled "1978 Ford Recreation Vehicles".

Ford Motor Company; excerpts from product brochure  
entitled "1978 Ford 4-Wheelers".

Ford Motor Company; excerpts from product brochure  
entitled "1978 Ford Bronco".

(List continued on next page.)

*Primary Examiner*—Melody N. Brown

(74) *Attorney, Agent, or Firm*—David B. Kelley

(57) **CLAIM**

The ornamental design for a vehicle side view mirror, as  
shown and described.

**DESCRIPTION**

FIG. 1 is a perspective view of a vehicle side view mirror in  
accordance with the present invention;

FIG. 2 is a rear view of the vehicle side view mirror of FIG.  
1;

FIG. 3 is a side view of the vehicle side view mirror of FIG.  
1;

FIG. 4 is a top view of the vehicle side view mirror of FIG.  
1;

FIG. 5 is a bottom view of the vehicle side view mirror of  
FIG. 1;

FIG. 6 is a front view of the vehicle side view mirror of FIG.  
1; and,

FIG. 7 is a perspective view of a vehicle side view mirror in  
accordance with a second embodiment of the present inven-  
tion.

The broken lines shown throughout the drawing are for  
illustrative purposes only and form no part of the claimed  
design. FIG. 7 is a mirror image of the first embodiment  
shown in FIGS. 1-6.

**1 Claim, 4 Drawing Sheets**

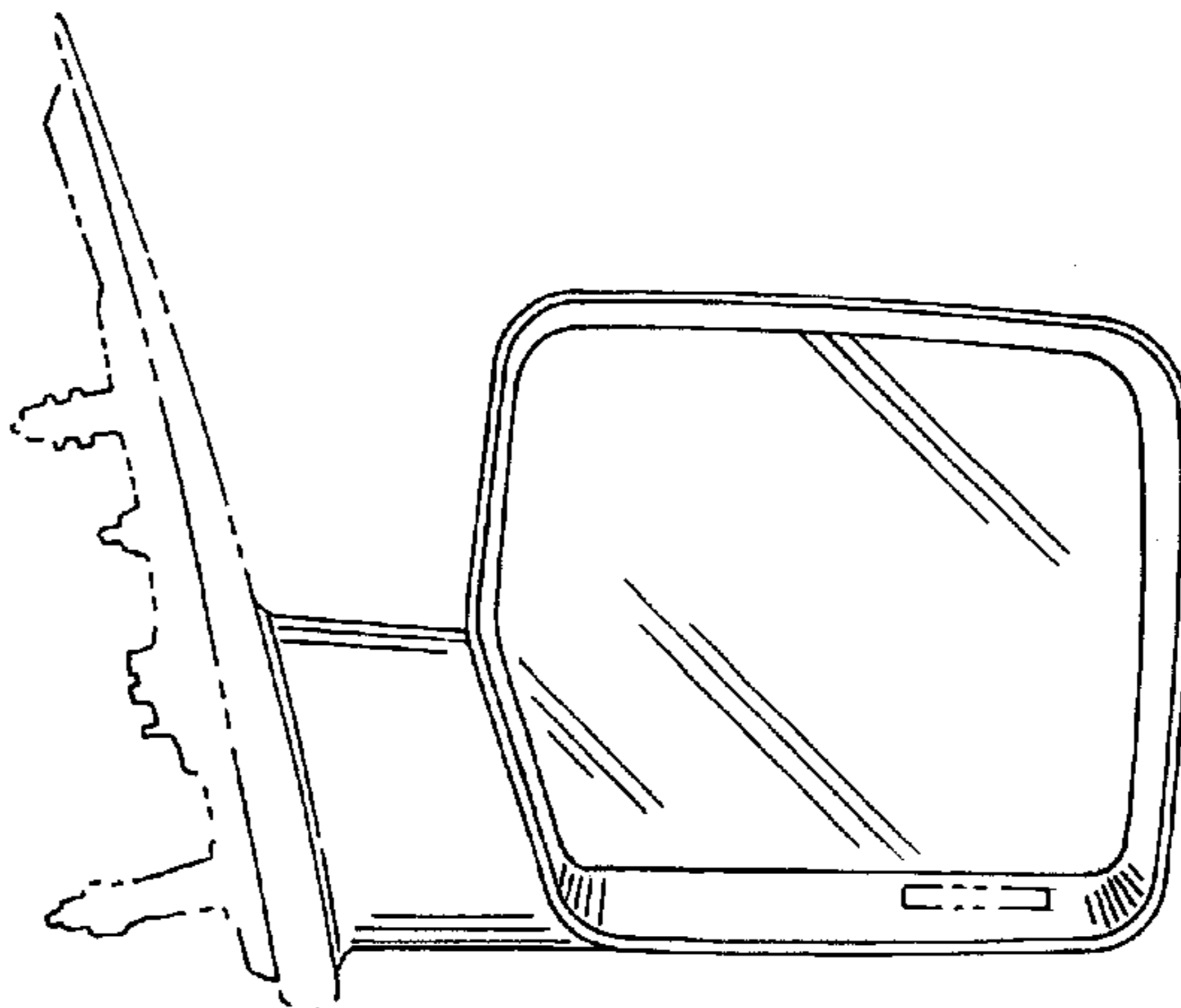

## OTHER PUBLICATIONS

- Ford Motor Company; excerpts from product brochure entitled "1978 Ford Club Wagons".
- Ford Motor Company, excerpts from product brochure entitled "Free Wheelin' Ford Trucks"; published circa 1977.
- Ford Motor Company; excerpts from product brochure entitled "1978 Ford Econoline".
- Ford Motor Company; excerpts from product brochure entitled "1978 Ford Courier".
- Ford Motor Company; excerpts from product brochure entitled "1979 Ford Recreation Vehicles".
- Ford Motor Company; excerpts from article entitled "Ford Club Wagon Van"; published circa 1978.
- Ford Motor Company; excerpts from product brochure entitled "1979 Ford 4-Wheelers".
- Ford Motor Company; excerpts from product brochure entitled "1979 Ford Club Wagons".
- Ford Motor Company; excerpts from product brochure entitled "'79 Free Wheelin' Ford Trucks".
- Ford Motor Company; excerpts from mail advertisement entitled "Ford Explorer Special Edition Sale"; published circa 1978.
- Ford Motor Company; excerpts from product brochure entitled "1979 Ford Courier".
- Ford Motor Company, excerpts from product brochure entitled "1979 Ford Econoline".
- Ford Motor Company; excerpts from product brochure entitled "Ford Truck Accesories"; published circa 1978.
- Ford Motor Company; excerpts from product brochure entitled "1979 Ford Bronco".
- Ford Motor Company; excerpts from product brochure entitled "1979 Ford Pickups".
- Ford Motor Company; excerpts from product brochure entitled "Ford 1980 Econoline Chassis".
- Ford Motor Company; excerpts from product brochure entitled "Pickup 4-Wheeler Bronco"; published circa 1979.
- Ford Motor Company; excerpts from product brochure entitled "1980 Bronco".
- Ford Motor Company; excerpts from product brochure entitled "Econoline/Club Wagon—1980 Confidential Preview".
- Ford Motor Company; excerpts from product brochure entitled "Ford 1980 Bronco".
- Ford Motor Company; excerpts from product brochure entitled "Ford 1980 Pickup".
- Ford Motor Company; excerpts from product brochure entitled "Ford 1980 Courier".
- Ford Motor Company; excerpts from product brochure entitled "1980 Free Wheelin' Fords".
- Ford Motor Company; excerpts from product brochure entitled "Ford 1980 4-Wheeler".
- Ford Motor Company; excerpts from product brochure entitled "Ford 1980 Econoline".
- Ford Motor Company; excerpts from product brochure entitled "The Captain's Club Wagon"; published circa 1979.
- Ford Motor Company; excerpts from product brochure entitled "Courier—1980 Confidential Preview".
- Ford Motor Company; excerpts from product brochure entitled "1980 Ford Courier".
- Ford Motor Company; excerpts from product brochure entitled "1980 F-Series".
- Ford Motor Company; excerpts from product brochure entitled "1980 Ford Bronco".
- Ford Motor Company; excerpts from product brochure entitled "1980 Ford Econoline".
- Ford Motor Company; excerpts from product brochure entitled "1980 Ford Bronco".
- Ford Motor Company; excerpts from product brochure entitled "Ford 1980 Club Wagon".
- Ford Motor Company; excerpts from product brochure entitled "Ford A-Serie"; published circa 1980.
- Ford Motor Company; excerpts from product brochure entitled "Pickups Ford"; published circa 1980.
- Ford Motor Company; excerpts from product brochure entitled "1981 Ford 4-Wheeler".
- Ford Motor Company; excerpts from product brochure entitled "1981 Ford Bronco".
- Ford Motor Company; excerpts from product brochure entitled "1981 Ford—The leadership lineup."
- Ford Motor Company; excerpts from product brochure entitled "1981 Ford Trucks".
- Ford Motor Company; excerpts from product brochure entitled "1981 Ford Club Wagon".
- Ford Motor Company; excerpts from product brochure entitled "1981 Ford Courier".
- Ford Motor Company; excerpts from product brochure entitled "1981 Ford Pickup".
- Ford Motor Company; excerpts from product brochure entitled "1981 Ford 4-Wheeler".
- Ford Motor Company; excerpts from product brochure entitled "1981 Ford Recreation Vehicles".
- Ford Motor Company; excerpts from product brochure entitled "1981 Ford Econoline Chassis".
- Ford Motor Company; excerpts from product brochure entitled "1981 Ford Econoline".
- Ford Motor Company; excerpts from product brochure entitled "1981 Ford Courier".
- Ford Motor Company; excerpts from product brochure entitled "Econoline/Club Wagon—1981 Confidential Preview".
- Ford Motor Company; excerpts from product brochure entitled "1981 Econoline Van/Club Wagon".
- Ford Motor Company; excerpts from product brochure entitled "1981 F-Series".
- Ford Motor Company; excerpts from product brochure entitled "1981 Bronco".
- Ford Motor Company; excerpts from product brochure entitled "F-Series—1981 Confidential Preview".
- Ford Motor Company; excerpts from product brochure entitled "Ford Truck Accessories and Specialties Catalog"; published circa 1982.
- Ford Motor Company; excerpts from product brochure entitled "'82 Ford Trucks".
- Ford Motor Company; excerpts from product brochure entitled "'82 Ford 4-Wheeler".
- Ford Motor Company; excerpts from product brochure entitled "'82 Ford Club Wagon".
- Ford Motor Company; excerpts from product brochure entitled "'82 Ford Econoline".
- Ford Motor Company; excerpts from product brochure entitled "'82 Ford Bronco".
- Ford Motor Company; excerpts from product brochure entitled "Ford 3000 I-Tonner"; published circa 1981.
- Ford Motor Company; excerpts from product brochure entitled "Ford 2400 Diesel 1-Tonner"; published circa 1981.
- Ford Motor Company; excerpts from product brochure entitled "'82 Ford F-Series Pickups".

- Ford Motor Company; excerpts from product brochure entitled "'82 Ford Econoline Chassis".
- Ford Motor Company; excerpts from product brochure entitled "1983 Ranger".
- Ford Motor Company; excerpts from product brochure entitled "America's Truck"; published circa 1982.
- Ford Motor Company; excerpts from product brochure entitled "1983 F-Series".
- Ford Motor Company; excerpts from product brochure entitled "1983 Bronco".
- Ford Motor Company; excerpts from product brochure entitled "1983 Econoline Van/Club Wagon".
- Ford Motor Company; excerpts from product brochure entitled "'83 Ford Bronco".
- Ford Motor Company; excerpts from product brochure entitled "'83 Ford Trucks".
- Ford Motor Company; excerpts from product brochure entitled "'83 Ford 4-Wheelers".
- Ford Motor Company; excerpts from product brochure entitled "1983 Ford Recreation Vehicles".
- Ford Motor Company; excerpts from product brochure entitled "'83 Ford Chassis Cab".
- Ford Motor Company; excerpts from product brochure entitled "'83 Ford Econoline".
- Ford Motor Company; excerpts from product brochure entitled "Ford 1600 I-Tonner LWB"; published circa 1982.
- Ford Motor Company; excerpts from product brochure entitled "Show Your Stripes—Create Bronco II Excitement"; published circa 1982.
- Ford Motor Company; excerpts from product brochure entitled "'83 Ford F-Series Pickup".
- Ford Motor Company; excerpts from product brochure entitled "'83 Ford Club Wagon".
- Ford Motor Company; excerpts from product brochure entitled "'83 Ford Trucks".
- Ford Motor Company; excerpts from product brochure entitled "'83 Ford Ranger".
- Ford Motor Company; excerpts from product brochure entitled "Ford Bronco II—It's A Brand New Kick!!".
- Ford Motor Company; excerpts from product brochure entitled "Accessories for Ford Light Trucks & Vans"; published circa 1983.
- Ford Motor Company; excerpts from product brochure entitled "1984 Ford Wagons".
- Ford Motor Company; excerpts from product brochure entitled "Aerostar Wars"; published circa 1983.
- Ford Motor Company; excerpts from product brochure entitled "Concept Aerostar"; published circa 1983.
- Ford Motor Company; excerpts from product brochure entitled "'84 Ford Trucks".
- Ford Motor Company; excerpts from product brochure entitled "1984 Ford Econoline Van".
- Ford Motor Company; excerpts from product brochure entitled "1984 Ford Club Wagon".
- Ford Motor Company; excerpts from product brochure entitled "Introducing the all new trim-size 1984 Ford Bronco II".
- Ford Motor Company; excerpts from product brochure entitled "1984 Ford Bronco II".
- Ford Motor Company; excerpts from product brochure entitled "1984 Ford Ranger".
- Ford Motor Company; excerpts from product brochure entitled "1984 Ford F-Series Pickup".
- Ford Motor Company; excerpts from product brochure entitled "1984 Ford Bronco".
- Ford Motor Company; excerpts from product brochure entitled "1984 Ford Chassis-Cab".
- Ford Motor Company; excerpts from product brochure entitled "1984 Ford Trucks".
- Ford Motor Company; excerpts from product brochure entitled "1984 Explorer Program".
- Ford Motor Company; excerpts from product brochure entitled "1985 Ford Bronco II".
- Ford Motor Company; excerpts from product brochure entitled "1985 Ford RV & Trailering Guide".
- Ford Motor Company; excerpts from product brochure entitled "1985 Ford Trucks".
- Ford Motor Company; excerpts from product brochure entitled "1985 Ford Trucks".
- Ford Motor Company; excerpts from product brochure entitled "1985 Ford Econoline Van".
- Ford Motor Company; excerpts from product brochure entitled "1985 Ford Club Wagon".
- Ford Motor Company; excerpts from product brochure entitled "1985 Ford Bronco".
- Ford Motor Company; excerpts from product brochure entitled "The Aussie Ute"; published circa 1984.
- Ford Motor Company; excerpts from product brochure entitled "1985 Ford Chassis-Cab".
- Ford Motor Company; excerpts from product brochure entitled "1985 F-Series Explorer Package 'A'".
- Ford Motor Company; excerpts from product brochure entitled "1985 Ford Ranger".
- Ford Motor Company; excerpts from product brochure entitled "Ford Bantam"; published circa 1984.
- Ford Motor Company; excerpts from product brochure entitled "1985 Concept Aerostar".
- Ford Motor Company; excerpts from product brochure entitled "Ford I-Tonner"; published circa 1984.
- Ford Motor Company; excerpts from product brochure entitled "F-Series Pickup"; published circa 1984.
- Ford Motor Company; excerpts from product brochure entitled "1985 Ford Wagons".
- Ford Motor Company; excerpts from product brochure entitled "1986 Ford Aerostar Wagon".
- Ford Motor Company; excerpts from product brochure entitled "Ford Aerostar Wagon"; published circa 1985.
- Ford Motor Company; excerpts from product brochure entitled "Ford Club Wagon"; published circa 1985.
- Ford Motor Company; excerpts from product brochure entitled "Ford Bronco"; published circa 1985.
- Ford Motor Company; excerpts from product brochure entitled "Ford Econoline"; published circa 1985.
- Ford Motor Company; excerpts from product brochure entitled "Der Transit"; published circa 1985.
- Ford Motor Company; excerpts from product brochure entitled "Der Econovan"; published circa 1985.
- Ford Motor Company; excerpts from product brochure entitled "1986 Ford Bronco".
- Ford Motor Company; excerpts from product brochure entitled "Ford I-Tonner 1600"; published circa 1984.
- Ford Motor Company; excerpts from product brochure entitled "Ford F-Series"; published circa 1985.
- Ford Motor Company; excerpts from product brochure entitled "Ford Light Trucks & Vans Accessories '86".

- Ford Motor Company; excerpts from product brochure entitled "Today's Crowd Pleasers—Spectron, Spectron Spacer, Spectron 4WD"; published circa 1985.
- Ford Motor Company; excerpts from product brochure entitled "1986 Ford Trucks".
- Ford Motor Company; excerpts from product brochure entitled "1986 Ford Econoline".
- Ford Motor Company; excerpts from product brochure entitled "Transportation Concept for the 80's and Beyond".
- Ford Motor Company; excerpts from product brochure entitled "1986 Ford F Series".
- Ford Motor Company; excerpts from product brochure entitled "1986 Ford Bronco II".
- Ford Motor Company; excerpts from product brochure entitled "1986 Ford Bronco".
- Ford Motor Company; excerpts from product brochure entitled "1986 Ford Chassis—Cab".
- Ford Motor Company; excerpts from product brochure entitled "1986 Ford Club Wagon".
- Ford Motor Company; excerpts from product brochure entitled "1986 Aerostar".
- Ford Motor Company; excerpts from product brochure entitled "1986 Aerostar Wagon".
- Ford Motor Company; excerpts from product brochure entitled "1986 Ford Ranger".
- Ford Motor Company; excerpts from product brochure entitled "1986 Ford Trucks".
- Ford Motor Company; excerpts from product brochure entitled "1987 Advance Light Truck Facts Book".
- Ford Motor Company; excerpts from product brochure entitled "1987 Ford Trucks".
- Ford Motor Company; excerpts from product brochure entitled "New Ford Courier 4WD"; published circa 1986.
- Ford Motor Company; excerpts from product brochure entitled "The Big Aussie Six"; published circa 1986.
- Ford Motor Company; excerpts from product brochure entitled "1987 Ford Chassis—Cab".
- Ford Motor Company; excerpts from product brochure entitled "1987 Ford Bronco".
- Ford Motor Company; excerpts from product brochure entitled "1987 Ford Econoline".
- Ford Motor Company; excerpts from product brochure entitled "1987 Ford Ranger".
- Ford Motor Company; excerpts from product brochure entitled "1987 Ford Club Wagon".
- Ford Motor Company; excerpts from product brochure entitled "1987 Ford Bronco II".
- Ford Motor Company; excerpts from product brochure entitled "1987 Ford Aerostar Wagon".
- Ford Motor Company; excerpts from product brochure entitled "1987 Ford Aerostar Van".
- Ford Motor Company; excerpts from product brochure entitled "1987 Ford F—Series Pickup".
- Ford Motor Company; excerpts from product brochure entitled "1988 Ford Wagons".
- Ford Motor Company; excerpts from product brochure entitled "New Ford F—Series."; published circa 1987.
- Ford Motor Company; excerpts from product brochure entitled "Maverick Wagon"; published circa 1987.
- Ford Motor Company; excerpts from product brochure entitled "Maverick Cab Chassis/Pick-up"; published circa 1987.
- Ford Motor Company; excerpts from product brochure entitled "1988 Ford Ranger".
- Ford Motor Company; excerpts from product brochure entitled "1988 Ford Bronco II".
- Ford Motor Company; excerpts from product brochure entitled "1988 Ford Bronco".
- Ford Motor Company; excerpts from product brochure entitled "1988 Ford Club Wagon".
- Ford Motor Company; excerpts from product brochure entitled "1988 Ford Econoline".
- Ford Motor Company; excerpts from product brochure entitled "1988 Ford Chassis—Cab".
- Ford Motor Company; excerpts from product brochure entitled "Ford Taurus Wagon, Ford Bronco 4x4"; published circa 1987.
- Ford Motor Company; excerpts from product brochure entitled "1988 Ford Aerostar Van".
- Ford Motor Company; excerpts from product brochure entitled "1988 Ford Aerostar Wagon".
- Ford Motor Company; excerpts from product brochure entitled "1988 Ford F—Series Pickup".
- Ford Motor Company; excerpts from product brochure entitled "Ranger"; published circa 1987.
- Ford Motor Company; excerpts from product brochure entitled "1988 Ford Trucks".
- Unknown Author; excerpts from newspaper section entitled "Auto Focus"; illustrating 1988 Ford F—series truck.
- Jan A. Zverina of United Press International.; excerpts from newspaper illustrating 1989 Ford Bronco II.
- Ford Motor Company; excerpts from magazine advertisement illustrating 1988 Ford Ranger entitled "Ranger Pickup Bed Cap".
- Ford Motor Company; excerpts from product brochure entitled "Ford Pre—Runner Ranger Packages—Accent Accessories 88".
- Ford Motor Company; excerpts from product brochure entitled "Electrically Powered F—Series Rear Window for Pickups."; published circa 1988.
- Ford Motor Company; excerpts from product brochure entitled "F—Series LPO"; published circa 1988.
- Ford Motor Company; excerpts from product brochure entitled "1989 Ford Trucks".
- Ford Motor Company; excerpts from product brochure entitled "Ford Light Trucks Accessories 89".
- Ford Motor Company; excerpts from product brochure entitled "1989 Ford Bronco II".
- Ford Motor Company; excerpts from product brochure entitled "1989 Ford Econoline/Club Wagon".
- Ford Motor Company; excerpts from product brochure entitled "1989 Ford Ranger".
- Ford Motor Company; excerpts from product brochure entitled "1989 Ford Aerostar".
- Ford Motor Company; excerpts from product brochure entitled "Commericals Oct. 1989".
- Ford Motor Company; excerpts from product brochure entitled "1989 Ford Club Wagon".
- Ford Motor Company; excerpts from product brochure entitled "1989 Ford F—Series".
- Ford Motor Company; excerpts from product brochure entitled "1989 Ford Ranger".
- Ford Motor Company; excerpts from product brochure entitled "1989 Ford Bronco".
- Ford Motor Company; excerpts from product brochure entitled "1989 Ford Aerostar Wagon".
- Ford Motor Company; excerpts from product brochure entitled "1990 F—Series Major Product Changes".

- Ford Motor Company; excerpts from product brochure entitled "1990 Econoline/Club Wagon Major Product Changes".
- Ford Motor Company; excerpts from product brochure entitled "1990 Aerostar Wagon and Van Major Product Changes".
- Ford Motor Company; excerpts from product brochure entitled "1990 Ford Recreation Vehicle and Trailer Towing Guide".
- Ford Motor Company; excerpts from product brochure entitled "Aerostar 4-Wheel Drive"; published circa 1989.
- Ford Motor Company; excerpts from product brochure entitled "Ford Trucks"; published circa 1989.
- Ford Motor Company; excerpts from product brochure entitled "Ford Club Wagon"; published circa 1989.
- Ford Motor Company; excerpts from product brochure entitled "Ford Aerostar Wagon"; published circa 1989.
- Ford Motor Company; excerpts from product brochure entitled "Ford Bronco II"; published circa 1989.
- Ford Motor Company; excerpts from product brochure entitled "1990 Ford F-Series".
- Ford Motor Company; excerpts from product brochure entitled "1990 Ford Econoline and Aerostar Vans".
- Ford Motor Company; excerpts from product brochure entitled "1990 Ford Bronco".
- Ford Motor Company; excerpts from product brochure entitled "1990 Ford Ranger".
- Ford Motor Company; excerpts from product brochure entitled "1990 Ford Chassis-Cab".
- Ford Motor Company; excerpts from product brochure entitled "1990 Ranger Major Product Changes".
- Ford Motor Company; excerpts from product brochure entitled "1990 Bronco Major Product Changes".
- Ford Motor Company; excerpts from product brochure entitled "1990 Bronco II Major Product Changes".
- Ford Motor Company; excerpts from product brochure entitled "1991 Aerostar Major Product Changes".
- Ford Motor Company; excerpts from product brochure entitled "1991 Ford Ranger".
- Ford Motor Company; excerpts from product brochure entitled "1991 Econoline/Club Wagon Major Product Changes".
- Ford Motor Company; excerpts from product brochure entitled "1991 Ranger Major Product Changes".
- Ford Motor Company; excerpts from product brochure entitled "New 1991 Ford Explorer . . .".
- Ford Motor Company; excerpts from product brochure entitled "1991 Ford Explorer".
- Ford Motor Company; excerpts from product brochure entitled "1991 Ford Trucks".
- David Sedgwick; excerpts from Detroit News article entitled "Explorer puts ford sport utility in driver's seat"; published circa 1991.
- Al Haas of Knight-Ridder Newspapers; excerpts from newspaper article entitled "Sport-utility vehicles brighten dark sales year"; published circa 1991.
- Ford Motor Company; excerpts from product brochure entitled "1991 Ford F-Series".
- Ford Motor Company; excerpts from product brochure entitled "Commercials —1992 Edition Two".
- James V. Higgins; excerpts from Detroit News article entitled "Ford's new Flareside pickups near-perfect F-series addition"; published circa 1992.
- Paul Lienert; excerpts from newspaper article entitled "Club Wagon sets the standard"; published circa 1992.
- Paul Eisenstein; excerpts from Detroit News article entitled "Ford to boost production on hot Explorers"; published circa 1992.
- Ford Motor Company; excerpts from product brochure entitled "1992 Ford Trucks".
- Ford Motor Company; excerpts from product brochure entitled "1992 Ford Club Wagon".
- Ford Motor Company; excerpts from product brochure entitled "Ford Commercial Trucks 1992, Vans".
- Ford Motor Company; excerpts from product brochure entitled "Ford 1992, Aerostar Wagon".
- Ford Motor Company; excerpts from product brochure entitled "Ford 1992, Bronco".
- Ford Motor Company; excerpts from product brochure entitled "1992 Ford F-Series, Flareside".
- Ford Motor Company; excerpts from product brochure entitled "Ford 1992, Explorer".
- Ford Motor Company; excerpts from product brochure entitled "Ford Trucks 1992, Ranger".
- Ford Motor Company; excerpts from product brochure entitled "Ford 1992, F-Series".
- Ford Motor Company; excerpts from product brochure entitled "Ford '93 F-Series".
- Ford Motor Company; excerpts from product brochure entitled "Ford '93 Ford Trucks".
- Ford Motor Company; excerpts from product brochure entitled "1993 Ranger".
- Ford Motor Company; excerpts from product brochure entitled "Ford '93 Ranger".
- Ford Motor Company; excerpts from product brochure entitled "Ford Commercial Trucks '93, Pickups & Chassis".
- Ford Motor Company; excerpts from product brochure entitled "Ford '93 Bronco".
- Ford Motor Company; excerpts from product brochure entitled "1993 Bronco".
- Ford Motor Company; excerpts from product brochure entitled "1993 F-Series".
- Ford Motor Company; excerpts from product brochure entitled "1993 Econoline/Club Wagon".
- Ford Motor Company; excerpts from product brochure entitled "1993 Aerostar".
- Ford Motor Company; excerpts from product brochure entitled "Utility Light Trucks & Vans Accessories"; published circa 1992.
- Ford Motor Company; excerpts from product brochure entitled "Ford '93, Explorer".
- Ford Motor Company; excerpts from product brochure entitled "Roll Along, Crew Cab DRW"; published circa 1992.
- Ford Motor Company; excerpts from product brochure entitled "Roll Along, Super Cab SRW"; published circa 1992.
- Ford Motor Company; excerpts from product brochure entitled "Roll Along, Crew Cab 4x4"; published circa 1992.
- Ford Motor Company; excerpts from product brochure entitled "Roll Along, Super Cab DRW"; published circa 1992.
- Ford Motor Company; excerpts from product brochure entitled "Roll Along, Bronco"; published circa 1992.
- Ford Motor Company; excerpts from product brochure entitled "Roll Along, Super Cab 4x4"; published circa 1992.

- James V. Higgins, Excerpts from Detroit News article entitled "1993 Ranger redesign makes a first-class pickup better"; published Jan. 20, 1993.
- Russ Devault of Atlanta Journal Constitution; excerpts from Detroit Free Press article entitled "Sporty components give the Lighting flexibility"; published Mar. 4, 1993.
- Unknown Author; excerpts from newspaper article illustrating a Ford Ranger XLT SuperCar 4x4; article entitled "Ford Ranger is unchallenged . . ."; published Feb. 25, 1993.
- James V. Higgins; excerpts from Detroit News article entitled "It's thumbs up for Lighting, but down for Mustang Cobra"; published May 12, 1993.
- Ford Motor Company; excerpts from product brochure entitled "F-Series"; published circa 1989.
- Ford Motor Company; excerpts from product brochure entitled "1990 Ford Bronco II".
- Ford Motor Company; excerpts from product brochure entitled "Ford 1992 Bronco".
- Ford Motor Company; excerpts from product brochure entitled "Ford Trucks 1992 Ranger".
- Ford Motor Company; excerpts from product brochure entitled "Ford 1992 Explorer".
- Ford Motor Company; excerpts from product brochure entitled "1992 Ford F-Series Flareside".
- Ford Motor Company; excerpts from product brochure entitled "Ford 1992 F-Series".
- Ford Motor Company; excerpts from product brochure entitled "Ford '93 F-Series".
- Ford Motor Company; excerpts from product brochure entitled "Ford 1994 F-Series".
- Ford Motor Company; excerpts from product brochure entitled "Ford 1994 Pickups & Chassis".
- Ford Motor Company; excerpts from product brochure entitled "Ford 1994 Explorer".
- Ford Motor Company; excerpts from product brochure entitled "Ford 1994 Ranger".
- Ford Motor Company; excerpts from product brochure entitled "1994 Ford F-150 Lightning".
- Ford Motor Company; excerpts from product brochure entitled "F-Series Pickup"; published circa 1993.
- Ford Motor Company; excerpts from product brochure entitled "1995 Ford Ranger".
- Ford Motor Company; excerpts from product brochure entitled "1995 Ford Bronco".
- Ford Motor Company; excerpts from product brochure entitled "1995 Ford Explorer".
- Ford Motor Company; excerpts from product brochure entitled "1996 Ford F-Series".
- Ford Motor Company; excerpts from product brochure entitled "1997 F-Series".
- Ford Motor Company; excerpts from product brochure entitled "The All-New 1997 Ford F-150".
- Ford Motor Company; excerpts from product brochure entitled "1997 F-150 Accessories".
- Ford Motor Company; excerpts from product brochure entitled "1997 Ranger".
- Ford Motor Company; excerpts from product brochure entitled "The Nineteen Hundred and Ninety Eight Ranger".
- Ford Motor Company; excerpts from product brochure entitled "The Nineteen Hundred and Ninety Eight Explorer".
- Ford Motor Company; excerpts from product brochure entitled "The Nineteen Hundred and Ninety Eight Expedition".
- Ford Motor Company; excerpts from product brochure entitled "Expedition Ninety Nine".
- Ford Motor Company; excerpts from product brochure entitled "Ranger Ninety Nine".
- Ford Motor Company; excerpts from product brochure entitled "Explorer Ninety Nine".
- Ford Motor Company; excerpts from product brochure entitled "F-Series Ninety Nine".
- Ford Motor Company; excerpts from product brochure entitled "Harley-Davidson F-150"; published circa 1998.
- Ford Motor Company; excerpts from product brochure entitled "Customized Ford F-150 SuperCrew"; published circa 1998.
- Ford Motor Company; excerpts from product brochure entitled "2001 Escape".
- Ford Motor Company; excerpts from product brochure entitled "Excursion"; published circa 1999.
- Tony Swan; excerpts from newspaper illustrating 2000 Ford Excursion; published Aug. 5, 1999.
- Anita and Paul Lienert; excerpts from newspaper illustrating 2000 Ford Excursion.
- Ford Motor Company; excerpts from product brochure entitled "Expedition"; published circa 1999.
- Ford Motor Company; excerpts from product brochure entitled "2000 Ford Expedition XLT, XLT with Premium Sport Appearance Group, Eddie Bauer".
- Ford Motor Company; excerpts from product brochure entitled "Explorer 4 Door"; published circa 1999.
- Ford Motor Company; excerpts from product brochure entitled "Explorer Sport"; published circa 1999.
- Ford Motor Company; excerpts from product brochure entitled "2000-01 Explorer Sport".
- Ford Motor Company; excerpts from product brochure entitled "Ford, 2000 (Explorer), Sport".
- Ford Motor Company; excerpts from product brochure entitled "Ford, 2000 (Explorer), XLS, XLS Sport, XLT, XLT Sport, Eddie Bauer, Limited".
- Ford Motor Company; excerpts from product brochure entitled "2001 Explorer Sport Trac".
- Ford Motor Company; excerpts from product brochure entitled "Ranger"; published circa 1999.
- Ford Motor Company; excerpts from product brochure entitled "2001 Supercrew".
- Ford Motor Company; excerpts from product brochure entitled "Super Duty F-Series"; published circa 1999.
- Ford Motor Company; excerpts from product brochure entitled "F-Series, 1000 F-150 Series"; published circa 1999.
- Ford Motor Company; excerpts from product brochure entitled "Super Duty, 200 F-250/350 F-Series Pickups"; published circa 1999.
- Ford Motor Company; excerpts from product brochure entitled "Windstar"; published circa 1999.
- Ford Motor Company; excerpts from product brochure entitled "Ford, 2000 Windstar".
- Ford Motor Company; excerpts from product brochure entitled "Ford, 2000 (Commercial Vehicles)".
- Ford Motor Company; excerpts from product brochure entitled "The Great Escape"; published circa 2000.
- Ford Motor Company; excerpts from product brochure entitled "2001 For DSVT F-150 Lightning".
- Ford Motor Company; excerpts from product brochure entitled "Over the Edge Ranger"; published circa 2000.

- Ford Motor Company; excerpts from product brochure entitled "Excursion Sightseer"; published circa 2000.
- Ford Motor Company; excerpts from product brochure entitled "Out Here, There are No Boundaries"; published circa 2001.
- Toyota Motor Corporation; excerpts from product brochure entitled "Toyota 1996 4Runner".
- Toyota Motor Corporation; excerpts from product brochure entitled "Toyota 1997 T100".
- Toyota Motor Corporation; excerpts from product brochure entitled "Toyota Tacoma".
- Mark Williams; excerpts from Four Wheeler magazine article entitled "Three pickups battle terrain—and each other—for the golden prize"; published circa 1997.
- Toyota Motor Corporation; excerpts from product brochure entitled "Toyota Tundra"; published circa 1998.
- Toyota Motor Corporation; excerpts from product brochure entitled "1998 Toyota RAV4".
- Toyota Motor Corporation; excerpts from product brochure entitled "1999 4Runner".
- Toyota Motor Corporation; excerpts from product brochure entitled "1999 Land Cruiser".
- Toyota Motor Corporation; excerpts from product brochure entitled "2002 Tacoma".
- General Motors Corporation; excerpts from product brochure entitled "2000 Shopper's Guide".
- General Motors Corporation; excerpts from product brochure entitled "Professional Grade Sierra"; published circa 1999.
- General Motors Corporation; excerpts from product brochure entitled "GMC Product Guide"; published circa 1999.
- General Motors Corporation; excerpts from product brochure entitled "Introducing the Sierra Sport Special Edition"; published circa 2000.
- General Motors Corporation; excerpts from product brochure entitled "Safari, Quick Facts"; published circa 2000.
- General Motors Corporation; excerpts from product brochure entitled "Jimmy, Quick Facts"; published circa 2000.
- General Motors Corporation; excerpts from product brochure entitled "Yukon Denali, Quick Facts"; published circa 2000.
- General Motors Corporation; excerpts from product brochure entitled "Sonoma, Quick Facts"; published circa 2000.
- General Motors Corporation; excerpts from product brochure entitled "Yukon, Quick Facts"; published circa 2000.
- General Motors Corporation; excerpts from product brochure entitled "Sierra Heavy Duty, Quick Facts"; published circa 2000.
- General Motors Corporation; excerpts from product brochure entitled "Sierra Light Duty, Quick Facts"; published circa 2000.
- General Motors Corporation; excerpts from product brochure entitled "2002 Envoy".
- General Motors Corporation; excerpts from product brochure entitled "2002 Yukon/Yukon Denali".
- General Motors Corporation; excerpts from product brochure entitled "2002 Sierra".
- The Dodge Corporation; excerpts from product brochure entitled "Sport Utility Defined."; published circa 1997.
- The Dodge Corporation; excerpts from product brochure entitled "More power. More Torque. More Towing. More Payload. More Room."; published circa 1997.
- The Dodge Corporation; excerpts from product brochure entitled "1998 Dakota, The New Dodge".
- The Dodge Corporation; excerpts from product brochure entitled "1998 Ram Pickup, The New Dodge".
- The Dodge Corporation; excerpts from product brochure entitled "Different to the Maxx"; published circa 1999.
- The Dodge Corporation; excerpts from product brochure entitled "1998 Durango, The New Dodge".
- The Dodge Corporation; excerpts from product brochure entitled "2001 Durango".
- The Dodge Corporation; excerpts from product brochure entitled "2001 Ram".
- The Dodge Corporation; excerpts from product brochure entitled "Ram 1500 2002".
- The Dodge Corporation; excerpts from product brochure entitled "Ram 2500/3500 2002".
- Chevrolet; excerpts from product brochure entitled "Suburban"; published circa 2001.
- Chevrolet; excerpts from product brochure entitled "2002".
- Chevrolet; excerpts from product brochure entitled "Blazer"; published circa 2001.
- Chevrolet; excerpts from product brochure entitled "Tahoe"; published circa 2001.
- Chevrolet; excerpts from product brochure entitled "Silverado"; published circa 2001.
- Chevrolet; excerpts from product brochure entitled "Commercial Vehicles"; published circa 2001.
- Chevrolet; excerpts from product brochure entitled "S10"; published circa 2001.
- Chevrolet; excerpts from product brochure entitled "Commercial Trucks"; published circa 2001.
- Chevrolet; excerpts from product brochure entitled "Tracker"; published circa 2001.
- Chevrolet; excerpts from product brochure entitled "Trail Blazer Ext"; published circa 2001.
- Chevrolet; excerpts from product brochure entitled "Trail Blazer"; published circa 2001.
- Chevrolet; excerpts from product brochure entitled "Avalanche"; published circa 2001.
- Chevrolet; excerpts from product brochure entitled "2004 Colorado".
- Chevrolet; excerpts from product brochure entitled "2005 Equinox".
- Mazda Motor Corporation; excerpts from product brochure entitled "IN H 4x2"; published circa 1998.
- Anita and Paul Lienert; excerpts from newspaper article entitled "Two extra doors increase utility of Mazda B series"; published Oct. 7, 1998.
- Mazda Motor Corporation; excerpts from product brochure entitled "B-Series Trucks"; published circa 1998.
- Mazda Motor Corporation; excerpts from product brochure entitled "Mazda B-Series Truck"; published circa 1997.
- Dan Lienert; excerpts from newspaper article entitled "All-new Mazda truck on outside houses pure Ranger on the inside"; published Aug. 6, 1997.
- Mazda Motor Corporation; excerpts from product brochure entitled "1998 Mazda B4000 4x4 SE Cab Plus".
- Mazda Motor Corporation; excerpts from product brochure entitled "The B-Series Trucks by Mazda"; published circa 1997.
- Rachel Konrad of Free Press Automotive Writer; excerpts from Detroit Free Press article entitled "Nissan steers new vehicles toward turnaround"; published Dec. 31, 1998.
- Tony Swan; excerpt from newspaper article entitled "Frontier Crew Cab shows the Nissan still has good ideas"; published Apr 29, 1999.

Paul Lienert; excerpt from The Detroit News article entitled "Nissan peers into the future"; published Aug. 5, 1998.

Nissan Motor Company; excerpts from product brochure entitled "1999 Nissan Frontier".

Nissan Motor Company; excerpts from product brochure entitled "Nissan Cars & Trucks 1998".

Nissan Motor Company; excerpts from product brochure entitled "Nissan Frontier 1998".

Nissan Motor Company; excerpts from product brochure entitled "2000 Frontier".

\* cited by examiner



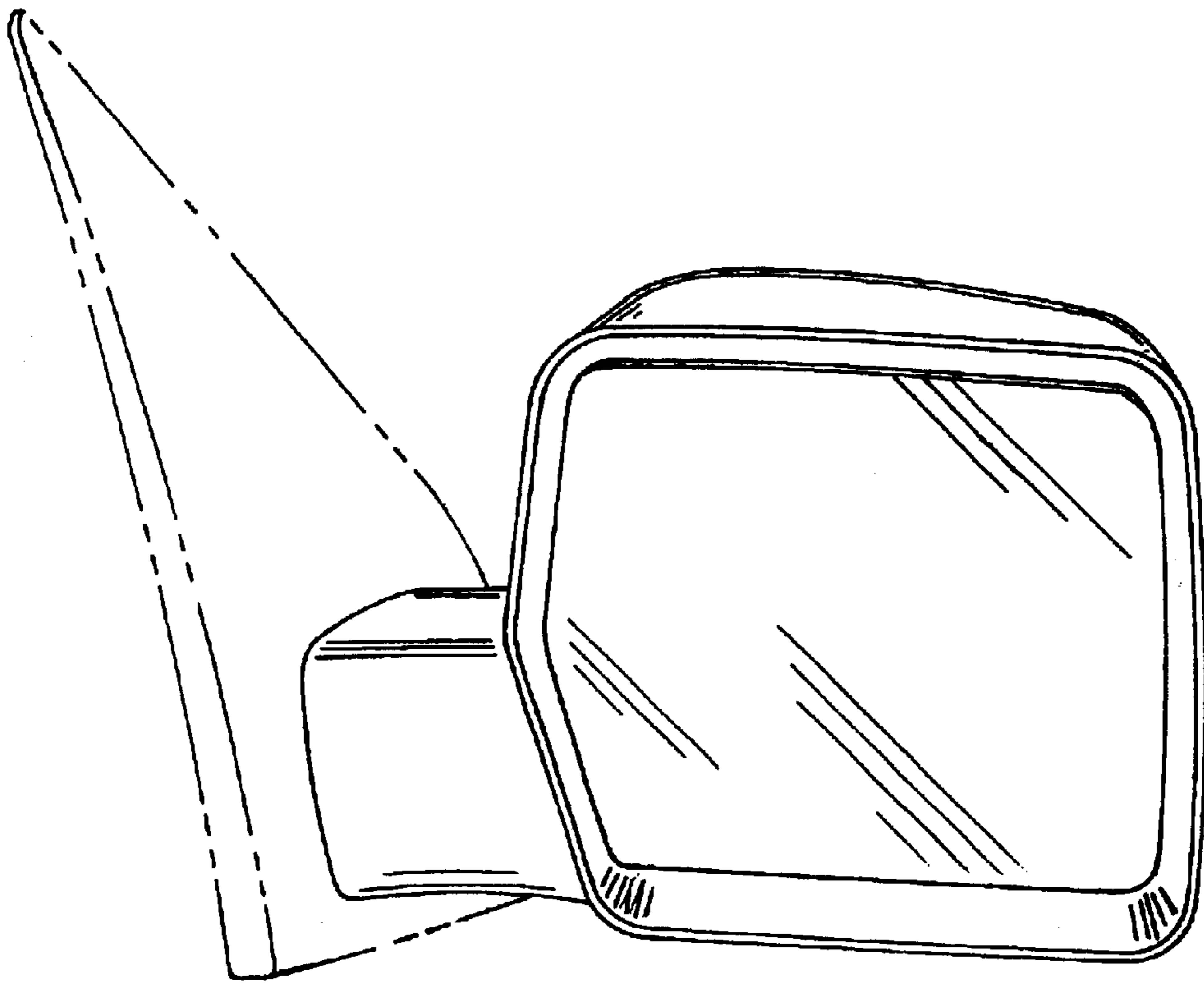

FIG. 1

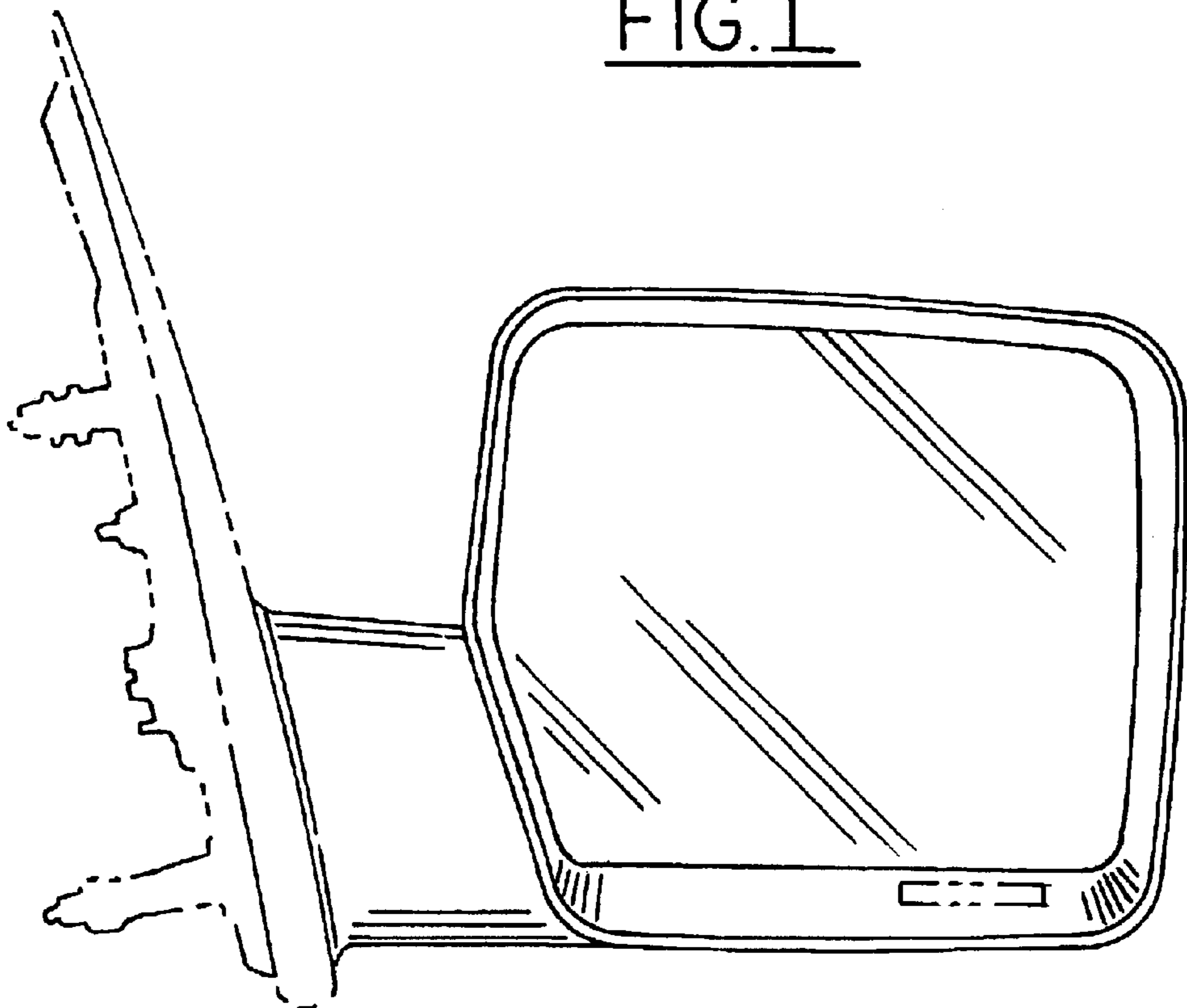

FIG. 2

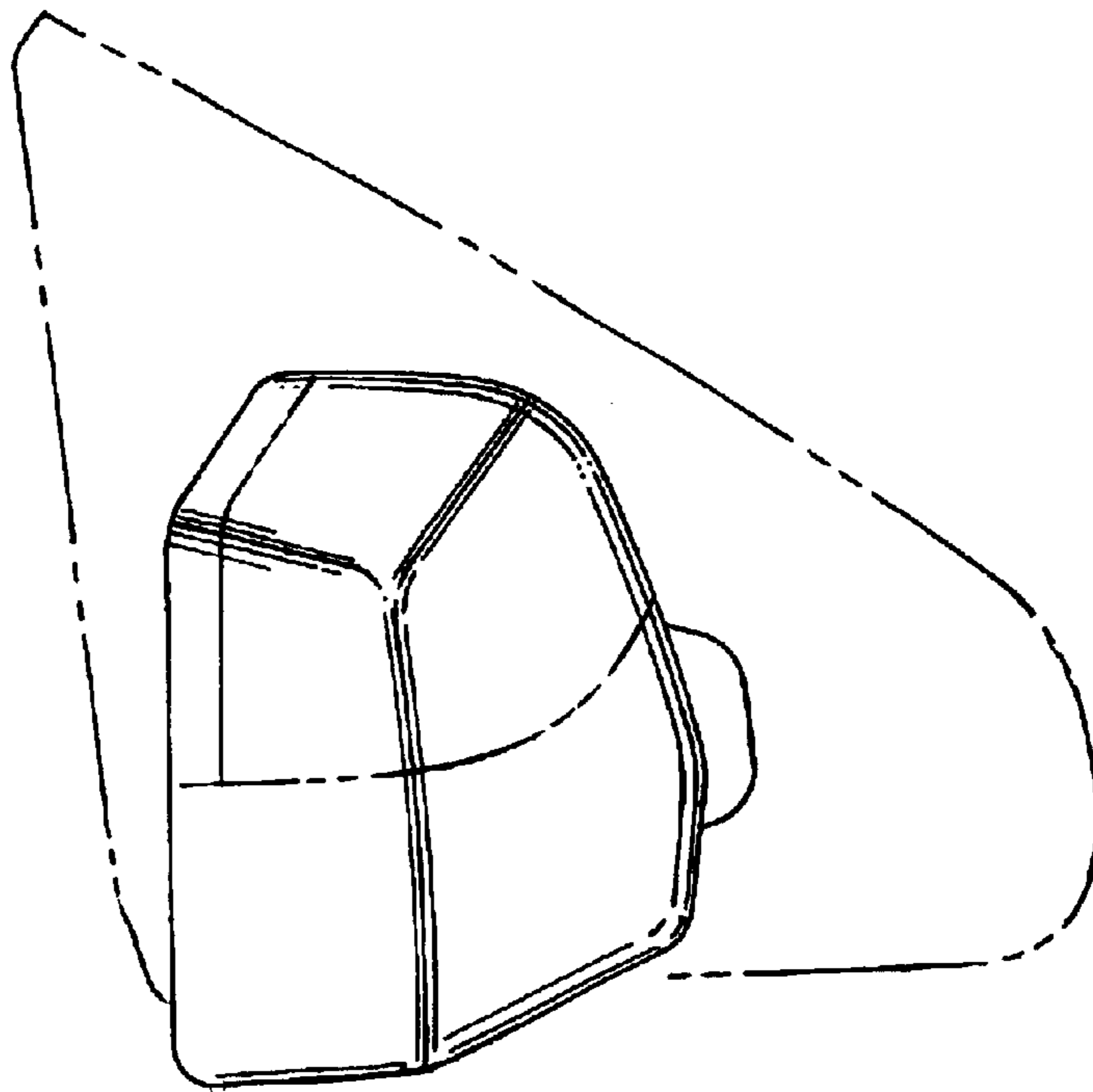

FIG. 3

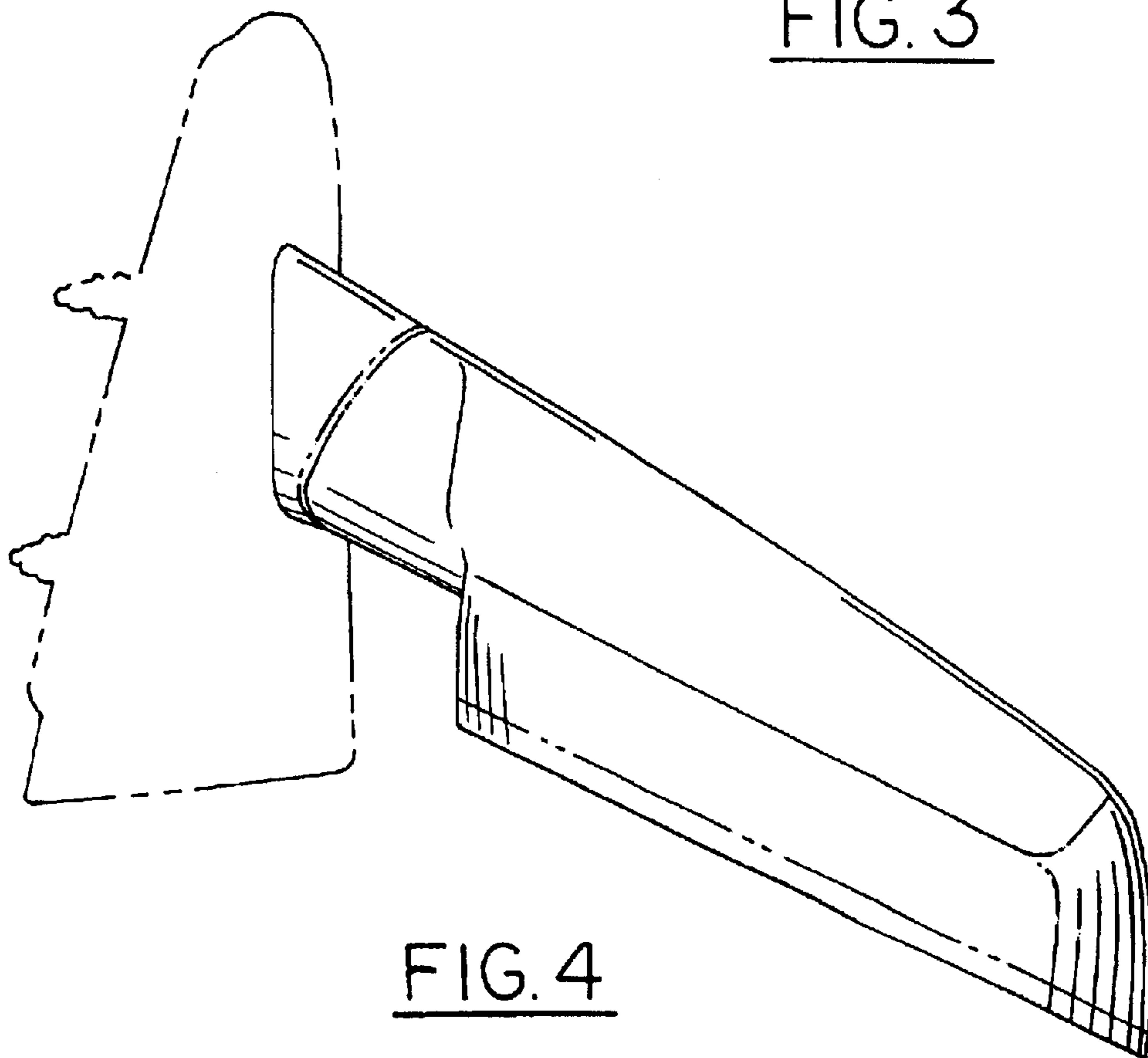

FIG. 4

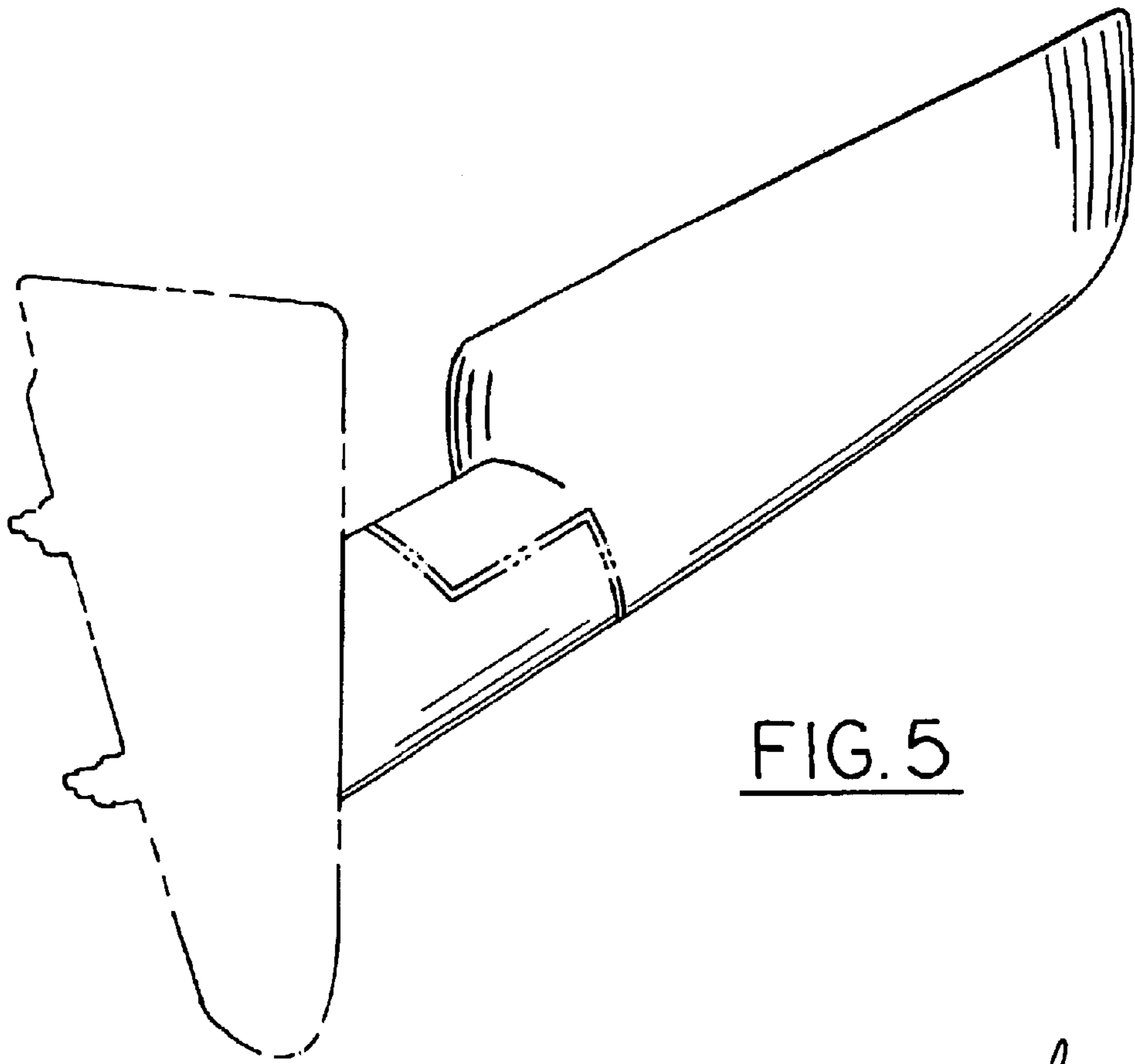

FIG. 5

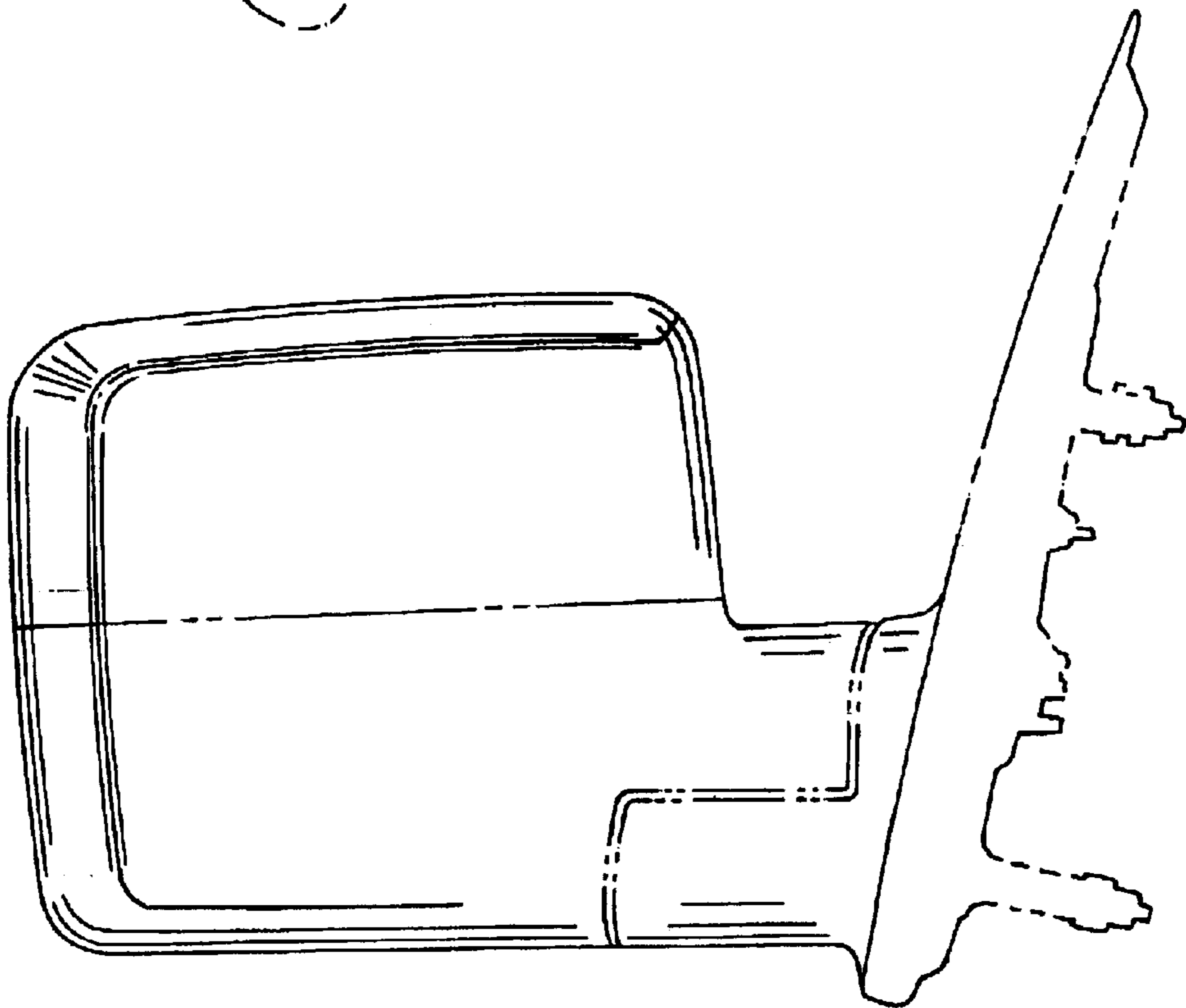

FIG. 6

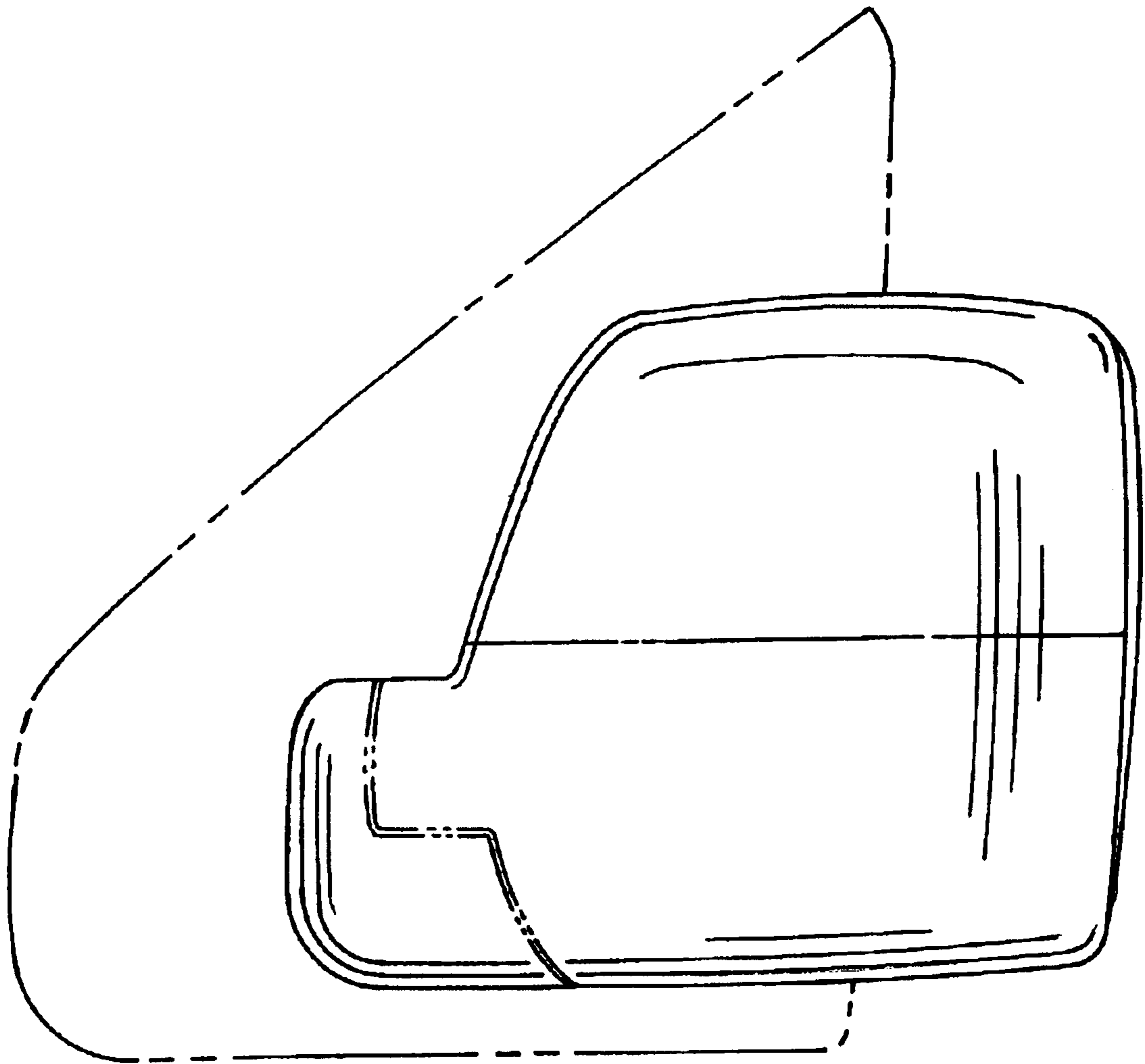

FIG. 7