



US00D489656S

(12) **United States Design Patent**
Kneefel et al.

(10) **Patent No.:** **US D489,656 S**

(45) **Date of Patent:** **** May 11, 2004**

(54) **VEHICLE RIGHT FRONT FENDER**

(75) Inventors: **Rolph Kneefel**, Livonia, MI (US);
Steve Park, Victoria (AU)

(73) Assignee: **Ford Global Technologies, LLC**,
Dearborn, MI (US)

(**) Term: **14 Years**

(21) Appl. No.: **29/173,301**

(22) Filed: **Dec. 26, 2002**

(51) **LOC (7) Cl.** **12-16**

(52) **U.S. Cl.** **D12/184; D12/196**

(58) **Field of Search** D12/184, 196,
D12/90-92; 280/152.1, 847-849, 851; 296/185

(56) **References Cited**

U.S. PATENT DOCUMENTS

D317,586 S * 6/1991 Yoshinao et al. D12/184
D417,424 S * 12/1999 Horbury et al. D12/196
D455,372 S * 4/2002 Myles et al. D12/98

OTHER PUBLICATIONS

Photographs of commercial parts—2 pages.

Lincoln-Mercury; excerpts from product brochure entitled
“2002 Mercury”.

Lincoln-Mercury; excerpts from product brochure entitled
“2002 Mercury Grand Marquis”.

Lincoln-Mercury; excerpts from product brochure; pub-
lished circa 2001.

Lincoln-Mercury; excerpts from product specification
entitled “2001 Mercury Grand Marquis”.

Lincoln-Mercury; excerpts from product brochure entitled
“Mercury 2000”.

Lincoln-Mercury; excerpts from product brochure entitled
“Mercury Grand Marquis 1999”.

Lincoln-Mercury; excerpts from product brochure entitled
“1998 Mercury Grand Marquis”.

Lincoln-Mercury; excerpts from product brochure entitled
“1998 Mercury Grand Marquis”.

Lincoln-Mercury; excerpts from product brochure entitled
“1998 Mercury Grand Marquis”.

Lincoln-Mercury; excerpts from product brochure entitled
“Presenting the new 1998 Mercury Grand Marquis”.

Lincoln-Mercury; excerpts from product entitled “1997
Grand Marquis”.

Lincoln-Mercury; excerpts from product brochure entitled
“Imagine Yourself In a Mercury; 1996-Sable-Mys-
tique-Villager-Grand Marquis-Cougar XR7-Tracer”.

Lincoln-Mercury; excerpts from product brochure entitled
“Imagine Yourself In a Mercury Grand Marquis; ’96 Mer-
cury”.

Lincoln-Mercury; excerpts from product brochure entitled
“Imagine Yourself In a Mercury Grand Marquis”.

Excerpts from article entitled “Mercury’s Hugh Grand Mar-
quis is an Agile, Friendly, Economical Dinosaur”; published
circa 1994.

(List continued on next page.)

Primary Examiner—Melody N. Brown

(74) *Attorney, Agent, or Firm*—Gigette Bejin

(57) **CLAIM**

The ornamental design for a vehicle right front fender, as
shown and described.

DESCRIPTION

FIG. 1 is a perspective view of a right front fender in
accordance with an embodiment of the present invention;
FIG. 2 is a side view of the right front fender shown in FIG.
1;

FIG. 3 is the other side view of the right front fender shown
in FIG. 1;

FIG. 4 is a front view of the right front fender of FIG. 1; and,
FIG. 5 is a top view of the right front fender of FIG. 1.

The bottom and rear views of the right front fender are not
part of the claimed design. The broken lines illustrate the
environment of the design and are not part of the claimed
design.

1 Claim, 2 Drawing Sheets

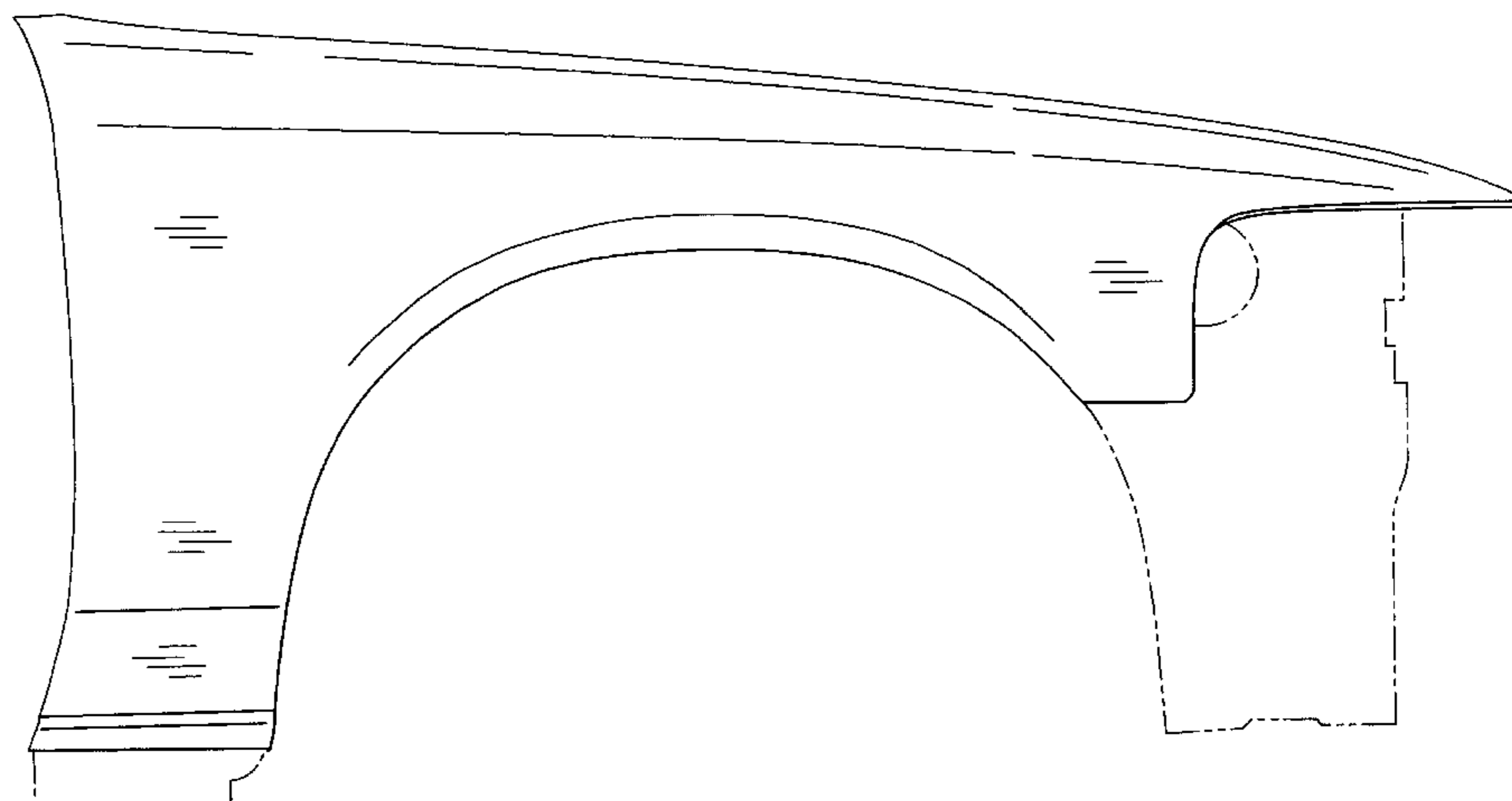

OTHER PUBLICATIONS

- Lincoln-Mercury; excerpts from product brochure entitled "1995 Mercury".
- Lincoln-Mercury; excerpts from product brochure entitled "1994 Product Information; Grand Marquis".
- Lincoln-Mercury; excerpts from product brochure entitled "1994 Mercurys. All this and the quality of a Mercury".
- Lincoln-Mercury; excerpts from product brochure entitled "1993 Mercury Grand Marquis".
- Lincoln-Mercury; excerpts from product brochure entitled "Mercury Grand Marquis"; published circa 1993.
- Lincoln-Mercury; excerpts from product brochure entitled "1992 Mercury, Sable, Grand Marquis, Cougar, Tracer, Topaz, Capri".
- Lincoln-Mercury; excerpts from product entitled "When You Think About Your Next Car Think On a Grand Scale"; published circa 1992.
- Lincoln-Mercury; excerpts from product brochure entitled "1992 Mercury Grand Marquis".
- Lincoln-Mercury; excerpts from product brochure entitled "Mercury Grand Marquis; Grand Marquis 1992".
- Excerpt from article entitled "92 Grand Marquis unveiled"; published circa Dec. 1990.
- Excerpt from article entitled "Big Changes In Store For '92 Marquis"; published circa Nov. 1990.
- Photograph of Mercury Grand Marquis from article; published circa 1992.
- Lincoln-Mercury; excerpts from product brochure entitled "1992 Mercury Grand Marquis Major Product Changes".
- Lincoln-Mercury; excerpts from product brochure entitled "Grand Marquis"; published circa 1991.
- Excerpt from article entitled "Grand Marquis Has The Juice" published circa 1991.
- Lincoln-Mercury; excerpts from product brochure entitled "Mercury-Cougar, Sable, Topaz, Tracer, Grand Marquis"; published circa 1990.
- Lincoln-Mercury; excerpts from product brochure entitled "Mercury '90 Grand Marquis".
- Lincoln-Mercury; excerpts from product brochure entitled "1990 Mercury Grand Marquis/Colony Park-major product changes".
- Lincoln-Mercury; excerpts from product brochure entitled "1998 Mercury Grand Marquis".
- Lincoln-Mercury; excerpts from product brochure entitled "Good Things Come in Preferred Equipment Packages"; published circa 1989.
- Lincoln-Mercury; excerpts from product brochure entitled "Mercury-Cougar, Sable, Topaz, Tracer, Grand Marquis"; published circa 1989.
- Lincoln-Mercury; excerpts from product brochure entitled "Mercury '89, Cougar, Sable, Topaz, Tracer, Grand Marquis".
- Lincoln-Mercury; excerpts from product brochure entitled "Mercury '89 Grand Marquis Brochure".
- Lincoln-Mercury; excerpts from product brochure entitled "Tracer, Topaz-Grand Marquis"; published circa 1988.
- Lincoln-Mercury; excerpts from product brochure entitled "1988 Grand Marquis".
- Lincoln-Mercury; excerpts from product brochure entitled "1987 Mercury".
- Lincoln-Mercury; excerpts from product brochure entitled "Tracer-Topaz-Grand Marquis-Sable-Cougar".
- Lincoln-Mercury; excerpts from product brochure entitled "Mercury '87, Sable/Cougar/Topaz/Lynx/Grand Marquis".
- Lincoln-Mercury; excerpts from product brochure entitled "Mercury Grand Marquis '86".
- Lincoln-Mercury; excerpts from product brochure entitled "Mercury '86, Sable/Cougar/Topaz/Lynx/Capri/Marquis/Grand Marquis".
- Lincoln-Mercury; excerpts from product brochure entitled "Mercury '85".
- Lincoln-Mercury; excerpts from product brochure entitled "Mercury Marquis '85".
- Lincoln-Mercury; excerpts from product brochure entitled "Mercury Grand Marquis '85".
- Lincoln-Mercury; excerpts from product brochure entitled "1985 Mercury-Competitive Comparisons".
- Lincoln-Mercury; excerpts from product brochure entitled "1985 Mercury-Competitive Comparisons".
- Lincoln-Mercury; excerpts from product brochure entitled "1985 Lincoln-Mercury, Close-up news bulletin No. 3".
- Lincoln-Mercury; excerpts from product brochure entitled "1984 Mercury Grand Marquis".
- Lincoln-Mercury; excerpts from product brochure entitled "1984 Lincoln-Mercury Advance Fleet Buyers Guide".
- Lincoln-Mercury; excerpts from product entitled "1984 Mercury, Topaz, Lynx, Capri, Cougar, Marquis, Grand Marquis".
- Lincoln-Mercury; excerpts from product brochure entitled "1983 Mercury Grand Marquis".
- Lincoln-Mercury; excerpts from product brochure entitled "1983 Mercury Grand Marquis".
- Lincoln-Mercury; excerpts from product brochure entitled "Fleet Facts 1983 Grand Marquis".
- Lincoln-Mercury; excerpts from product brochure entitled "Lincoln-Mercury for 1983".
- Lincoln-Mercury; excerpts from product entitled "1983 fleet programs for Lincoln-Mercury Car Lines".
- Lincoln-Mercury; excerpts from product brochure entitled "Mercury '83".
- Lincoln-Mercury; excerpts from product brochure entitled "Mercury Grand Marquis '83".
- Lincoln-Mercury; excerpts from product brochure entitled "Mercury Marquis"; published circa 1983.

* cited by examiner

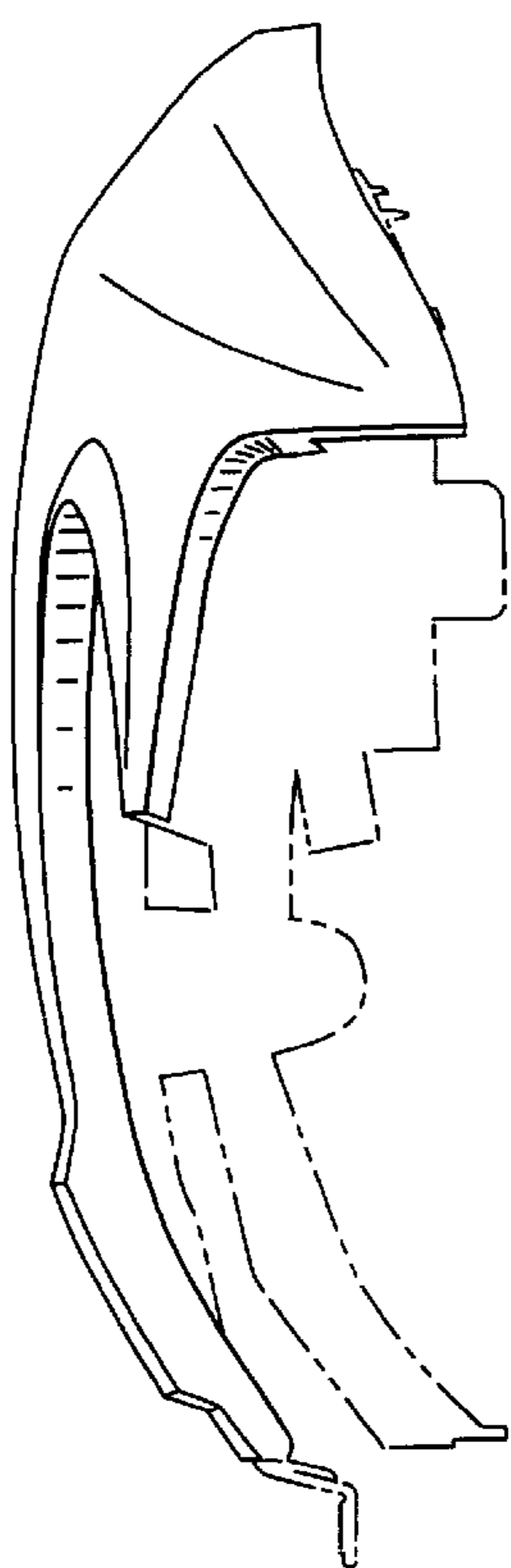
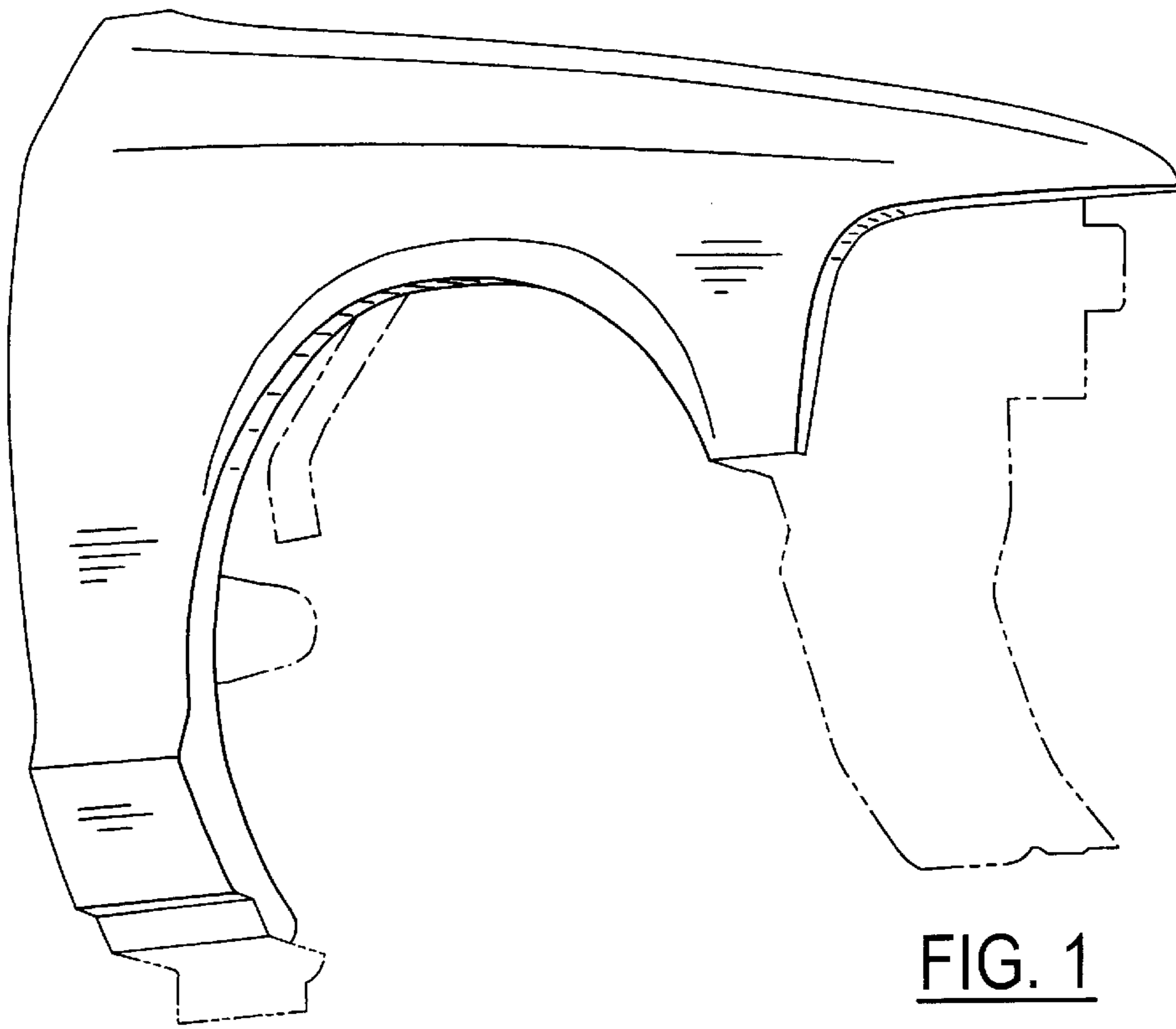
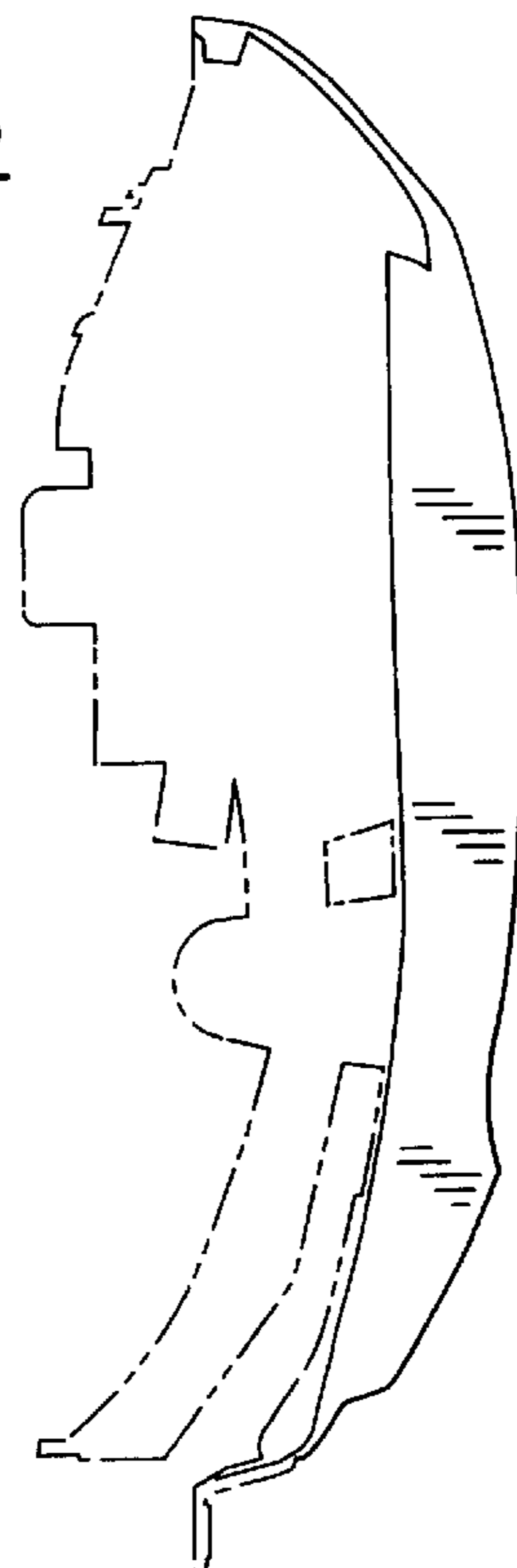

FIG. 3



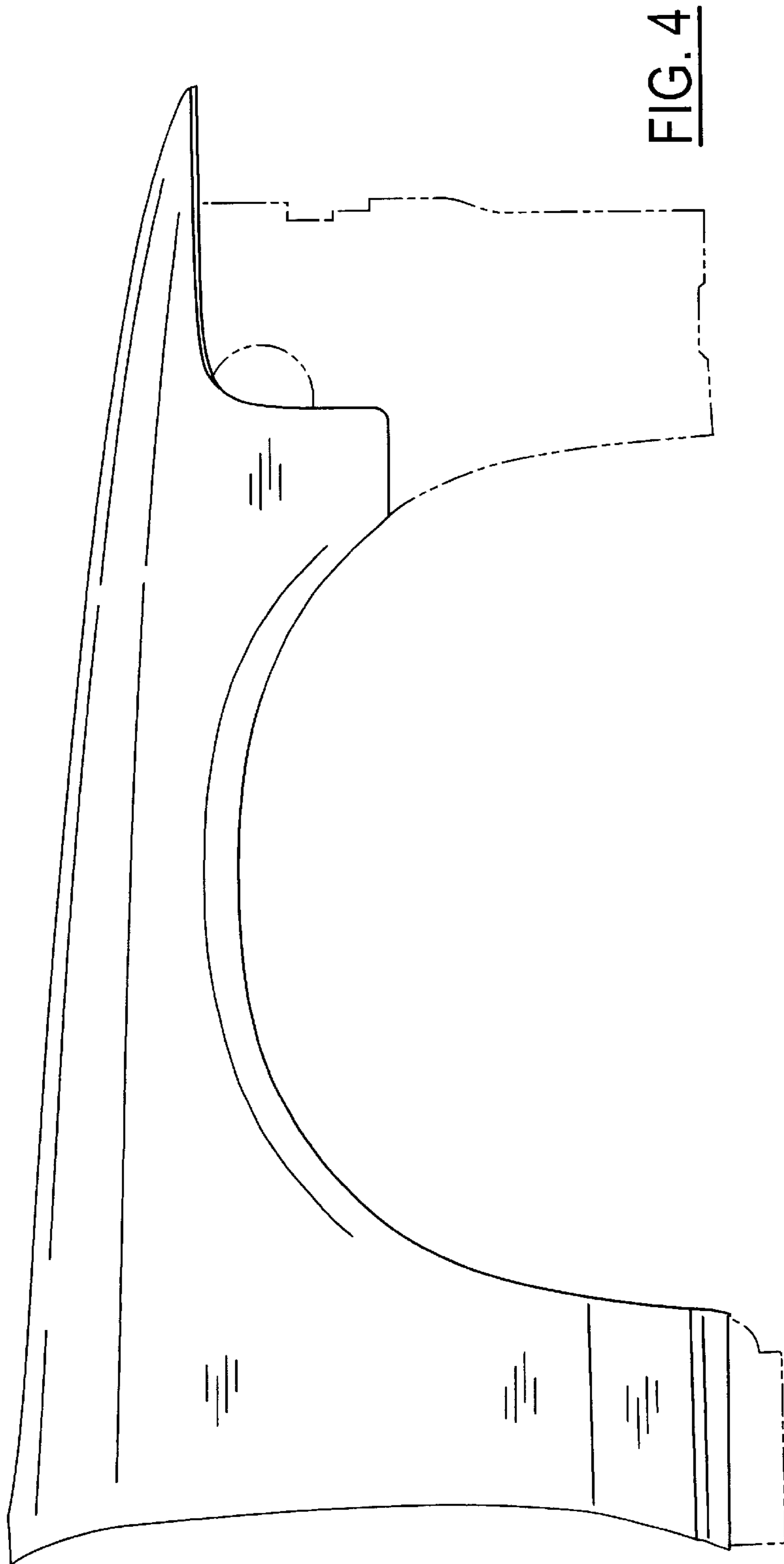

FIG. 4

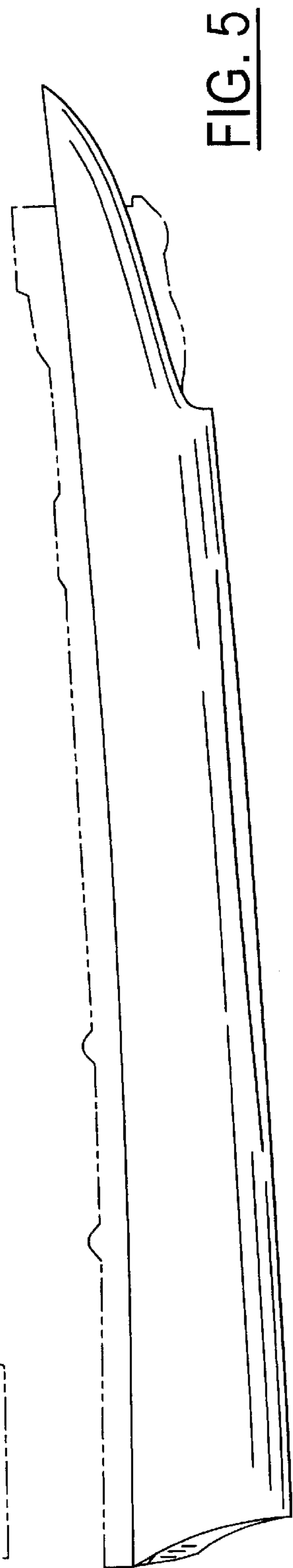

FIG. 5