



US00D489395S

(12) **United States Design Patent**
Sewell

(10) **Patent No.:** **US D489,395 S**

(45) **Date of Patent:** **** May 4, 2004**

(54) **NECKLESS LAP GUITAR**

(76) **Inventor:** **David L. Sewell**, 527 Northport Dr.
Apt. 3, Madison, WI (US) 53704

(**) **Term:** **14 Years**

(21) **Appl. No.:** **29/177,041**

(22) **Filed:** **Mar. 3, 2003**

(51) **LOC (7) Cl.** **17-03**

(52) **U.S. Cl.** **D17/14**

(58) **Field of Search** D17/14, 15, 19-21,
D17/99; 84/267, 268, 291, 294, 290, 192;
D21/405

(56) **References Cited**

U.S. PATENT DOCUMENTS

| | | | |
|---------------|---------|--------------|--------|
| 72,591 A | 12/1867 | Bini | |
| 475,541 A * | 5/1892 | Cross | 84/291 |
| D28,340 S | 3/1898 | Baehr | |
| 627,067 A * | 6/1899 | Simpson | 84/268 |
| 636,692 A | 11/1899 | Patch | |
| 860,350 A * | 7/1907 | Clopton | 84/268 |
| 989,510 A | 4/1911 | McCullough | |
| 1,047,217 A * | 12/1912 | Hartnett | 84/294 |
| D43,684 S * | 3/1913 | Weymann | |
| 1,183,369 A | 5/1916 | Gardie | |
| 1,304,914 A | 5/1919 | Smith | |
| 1,335,010 A | 3/1920 | Morris | |
| 1,364,217 A | 1/1921 | Surratt | |
| 1,426,852 A | 8/1922 | Frozeth | |
| 1,650,112 A * | 11/1927 | Charlston | 84/268 |
| 1,768,261 A | 6/1930 | Larson | |
| 1,834,804 A | 12/1931 | Puoina | |
| 1,839,244 A | 1/1932 | Meisel | |
| 1,889,408 A | 11/1932 | Larson | |
| 2,449,124 A | 9/1948 | Kimmons | |
| 2,800,050 A | 7/1957 | Gregg et al. | |
| D208,949 S * | 10/1967 | Jennings | D17/14 |
| 3,561,314 A | 2/1971 | MacEachron | |

(List continued on next page.)

OTHER PUBLICATIONS

Egyptian Oud—<http://www.apollosaxes.com/egyptianoud.html> (Oct. 25, 2002).

Oud—<http://www.apollosaxes.com/oud.html> (Oct. 25, 2002).

Lute—<http://www.apollosaxes.com/lute.html> (Oct. 25, 2002).

Laouta—<http://www.apollosaxes.com/laouta.html> (Oct. 25, 2002).

Mandolin from Amigo—<http://www.apollosaxes.com/man-froman.htm>. (Oct. 25, 2002).

Dilruba—<http://www.buckinghammusic.com/dilruba/dilruba.html> (Oct. 25, 2002).

Sarode—<http://www.buckinghammusic.com/sarod/sarod.html> (Oct. 25, 2002).

Primary Examiner—Ruth McInroy

(74) *Attorney, Agent, or Firm*—LaFollette Godfrey & Kahn; Sonali S. Srivastava

(57) **CLAIM**

The ornamental design of a neckless lap guitar, as shown and described.

DESCRIPTION

FIG. 1 is a perspective view of a neckless lap guitar showing my new design;

FIG. 2 is a top plan view of the neckless guitar shown in FIG. 1;

FIG. 3 is a side plan view of the neckless guitar shown in FIG. 1;

FIG. 4 is a bottom plan view of the neckless guitar shown in FIG. 1;

FIG. 5 is a rear end view of the neckless guitar shown in FIG. 1 as viewed from a peg head end;

FIG. 6 is a front end view of the neckless guitar shown in FIG. 1 as viewed from a acoustic chamber end;

FIG. 7 is an enlarged exploded perspective view of the top end of the guitar shown in FIG. 1 wherein a peg head block and the peg head are capable of forming a mortise and tenon joint; and,

FIG. 8 is an exploded perspective view of the guitar shown in FIG. 1, revealing supporting braces.

FIG. 7 is shown separate for clarity of illustration only.

1 Claim, 5 Drawing Sheets

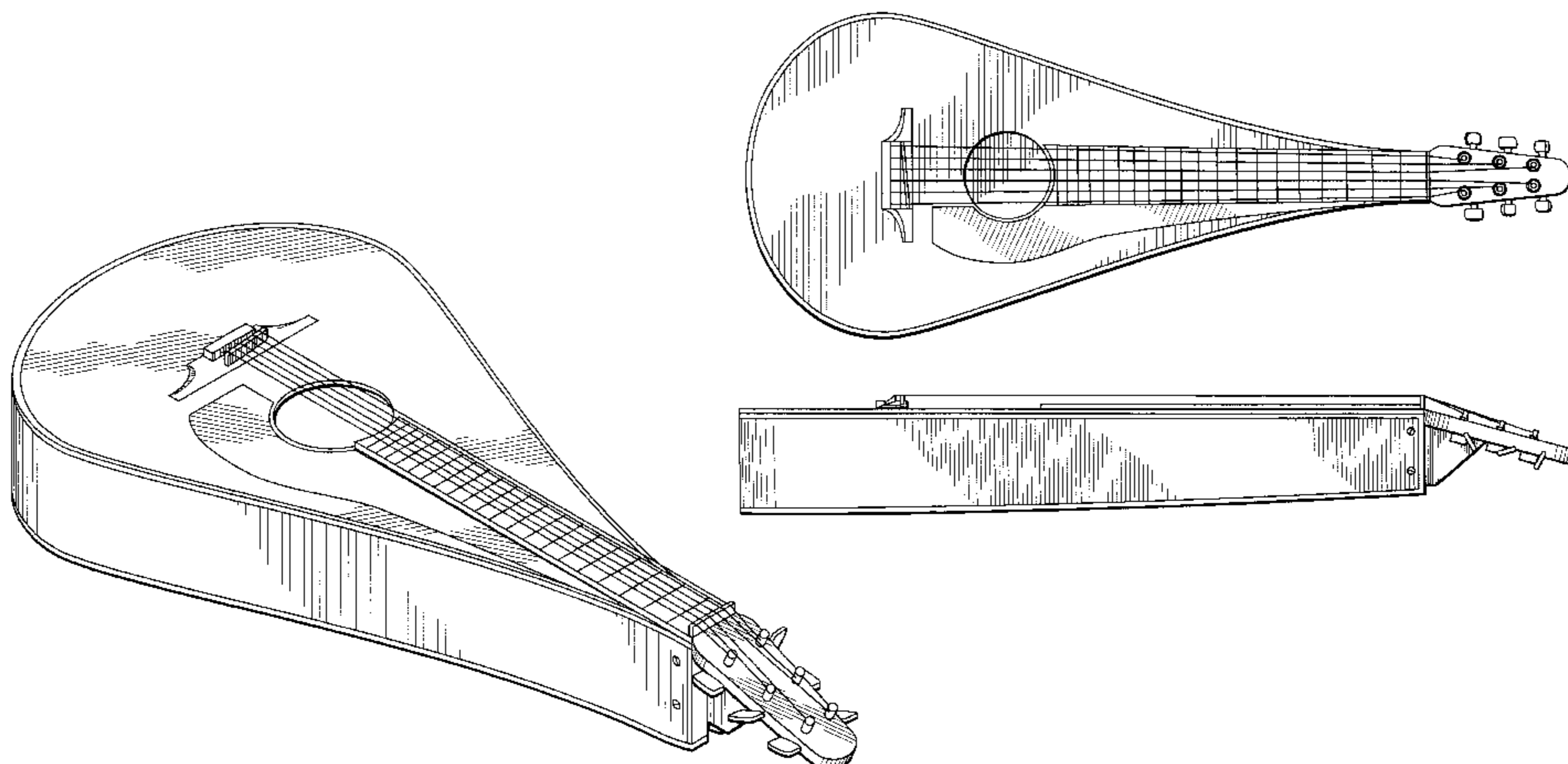

US D489,395 S

Page 2

U.S. PATENT DOCUMENTS

| | | | | | | | |
|-----------|---|-----------|----------------|-----------|----|---------|-----------------|
| 3,685,385 | A | 8/1972 | Rendell | 5,469,770 | A | 11/1995 | Taylor |
| 3,853,032 | A | 12/1974 | Freeman | D384,689 | S | 10/1997 | Najarian |
| 3,892,159 | A | 7/1975 | Houtsma | 5,811,704 | A | 9/1998 | Anderko |
| 3,974,730 | A | 8/1976 | Adams, Jr. | 5,895,872 | A | 4/1999 | Chase |
| D249,980 | S | * 10/1978 | Eventoff | 5,952,592 | A | 9/1999 | Teel |
| | | | D17/19 | D415,517 | S | 10/1999 | Hagerman et al. |
| 4,881,441 | A | 11/1989 | Larsen | 6,166,308 | A | 12/2000 | Lam |
| 5,339,718 | A | 8/1994 | Leduc | 6,459,024 | B1 | 10/2002 | Baker |
| 5,406,874 | A | 4/1995 | Witchel | | | | |

* cited by examiner

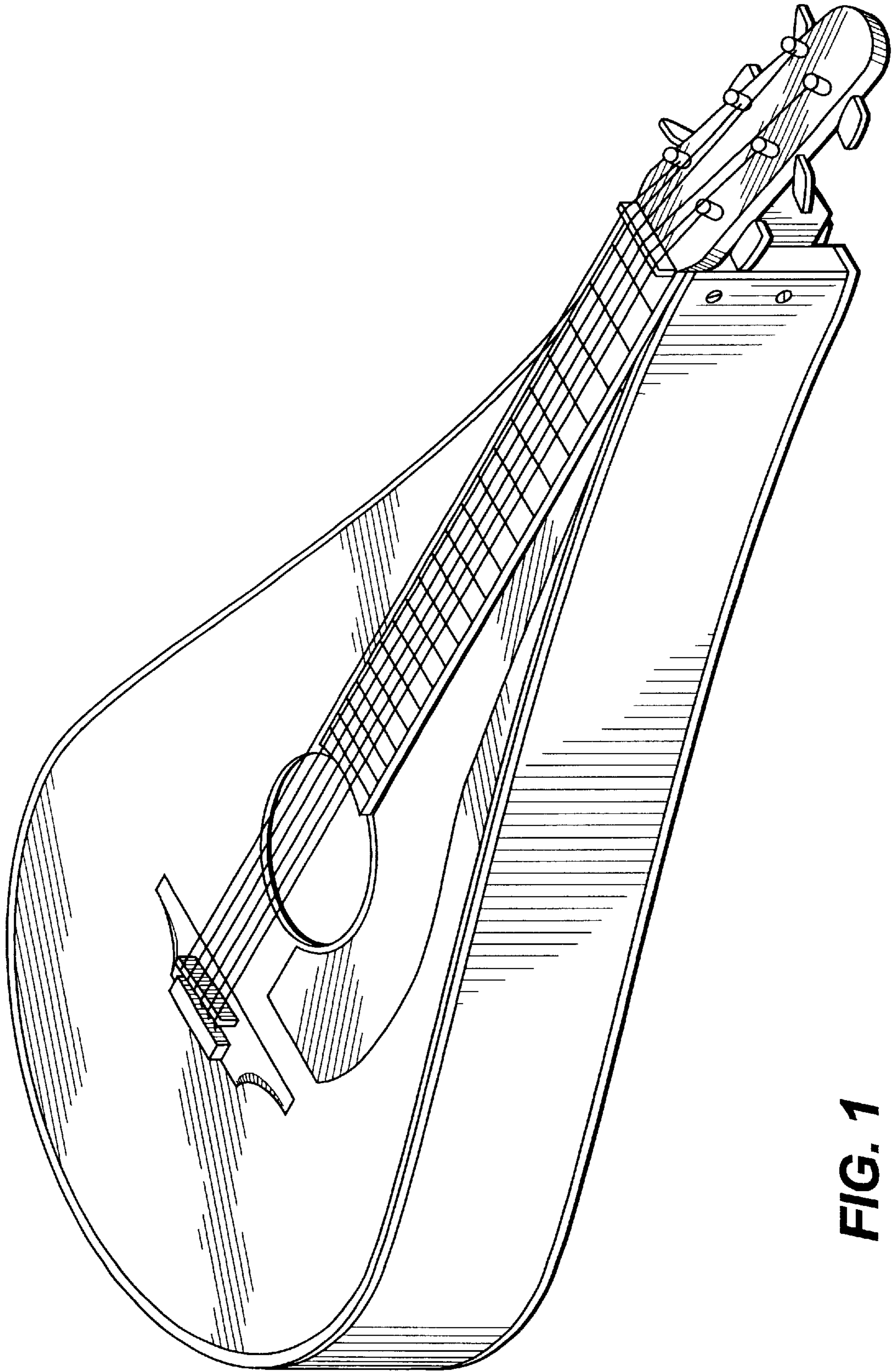

FIG. 1

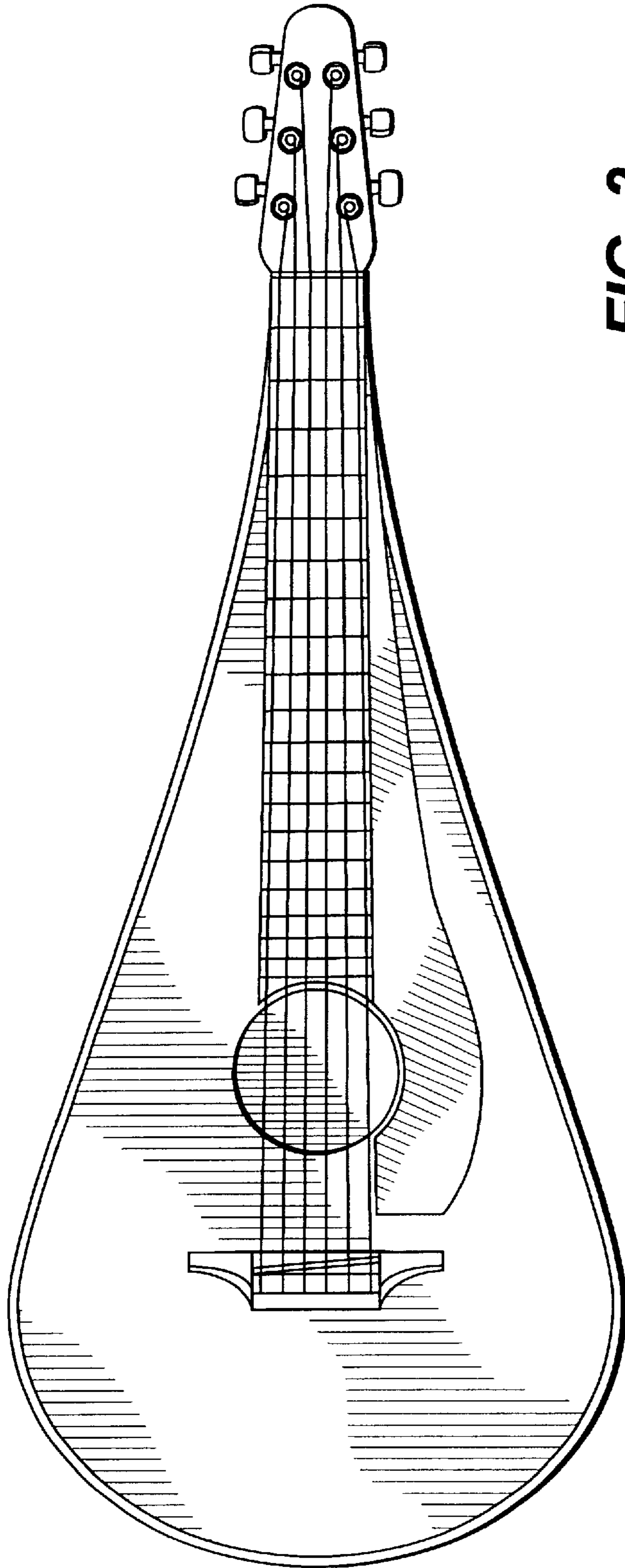

FIG. 2

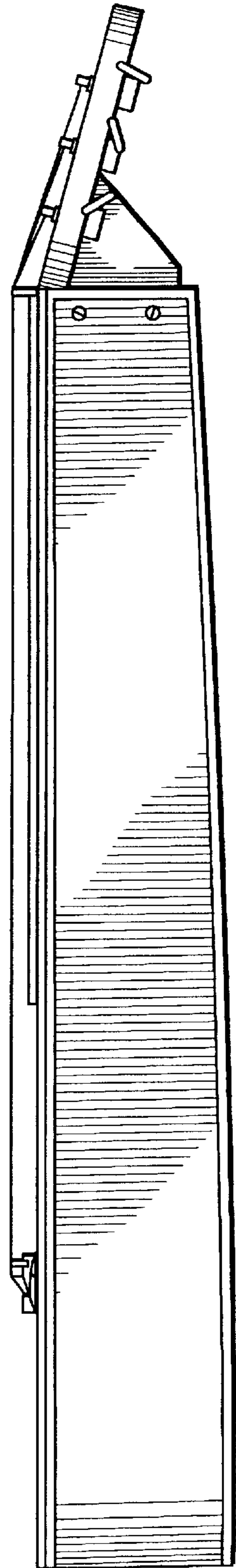

FIG. 3

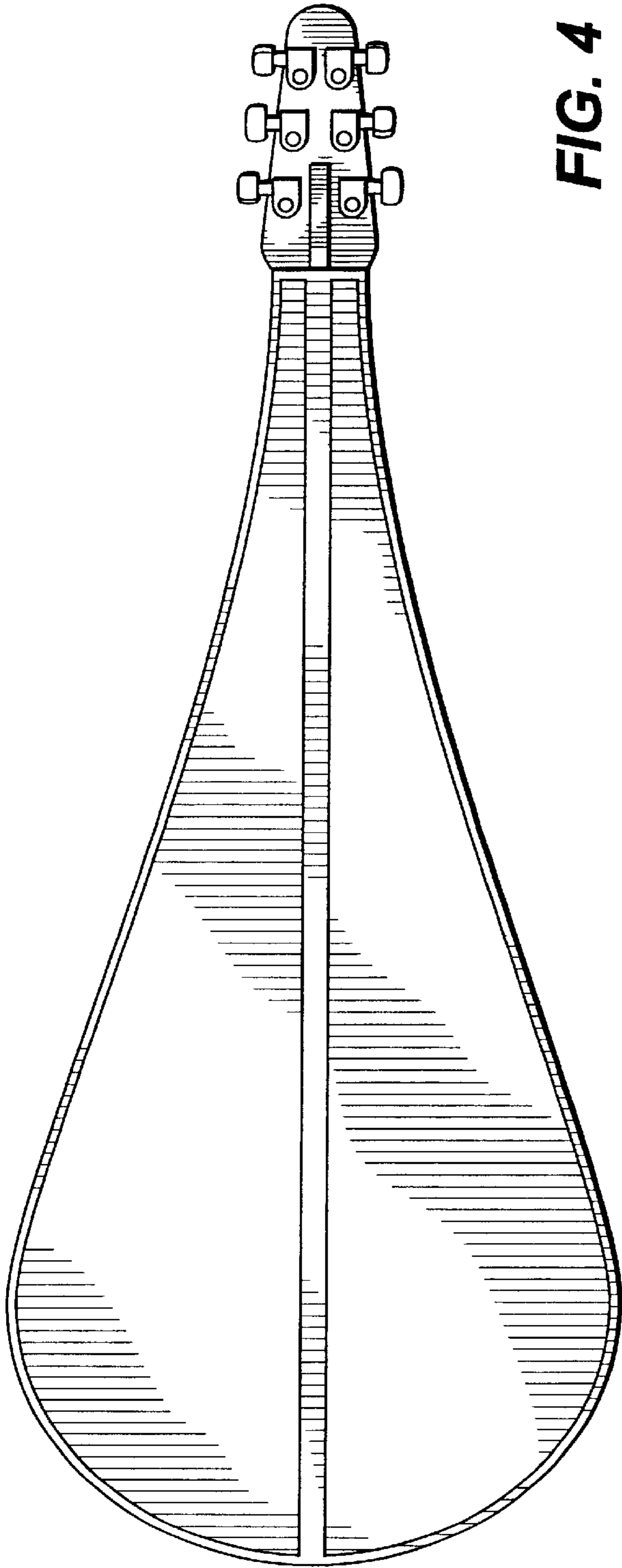

FIG. 4

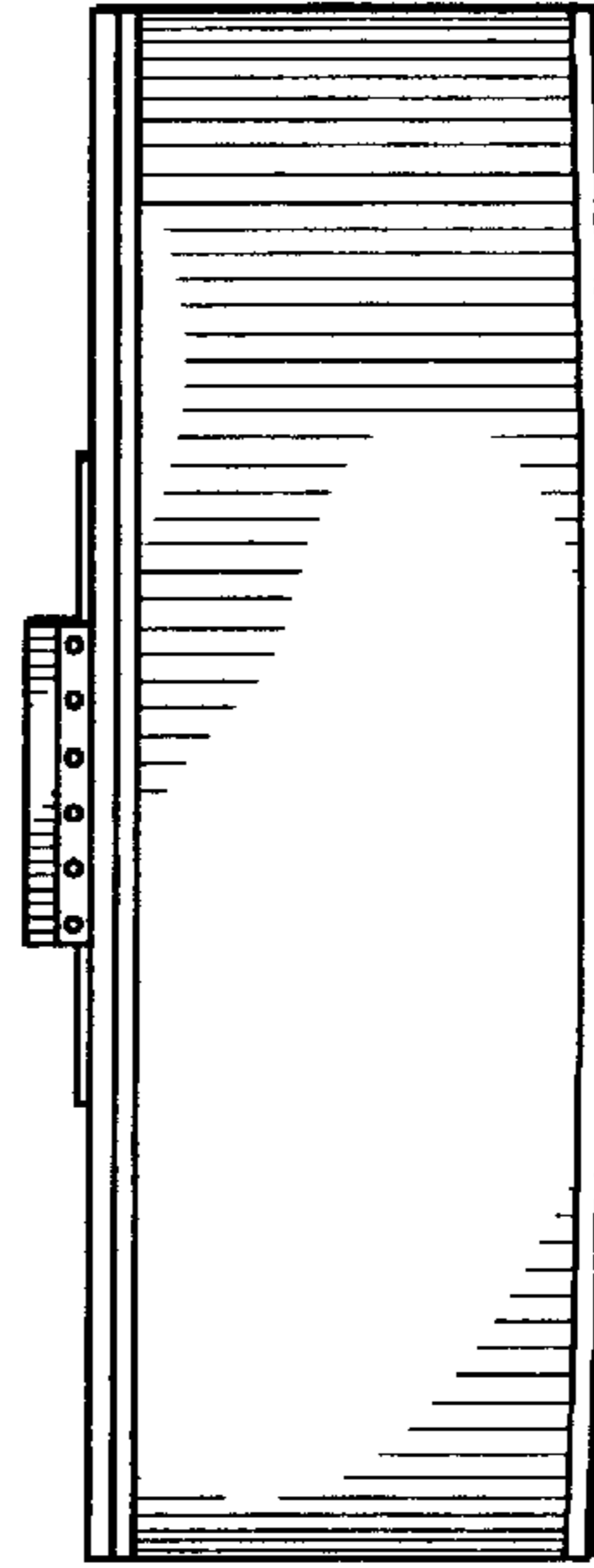

FIG. 6

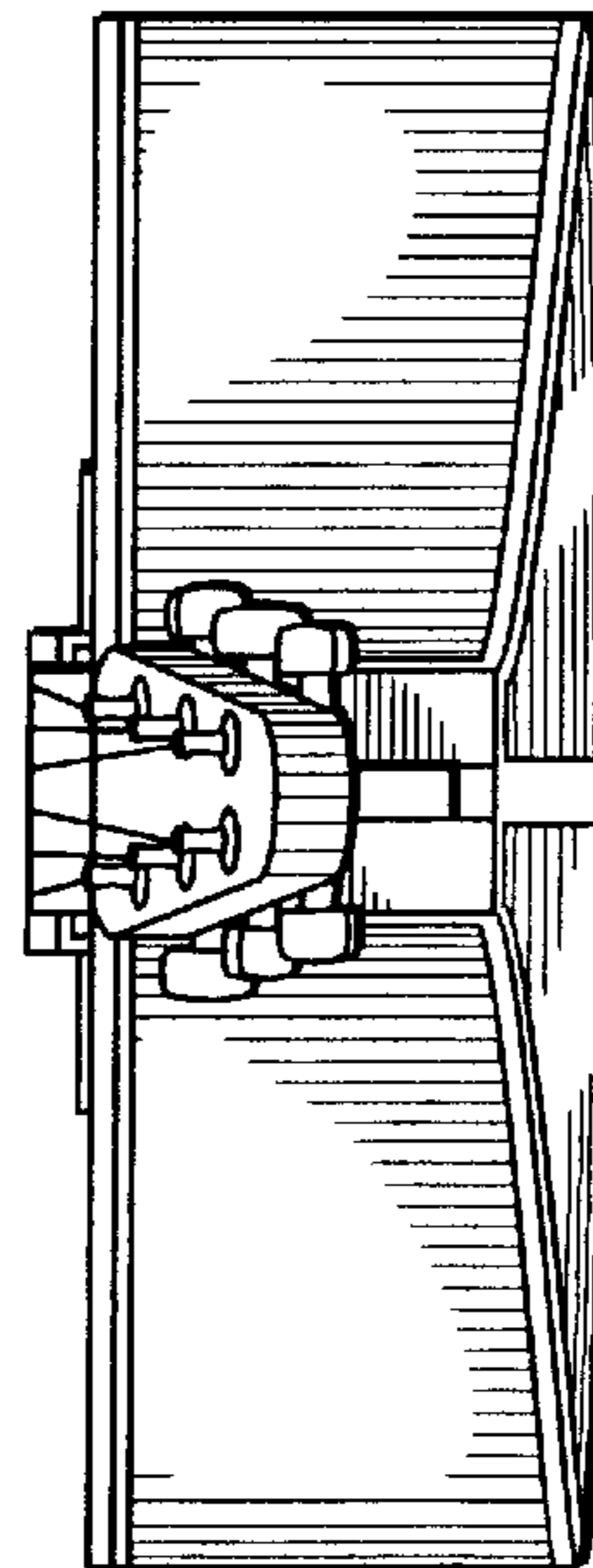

FIG. 5

FIG. 7

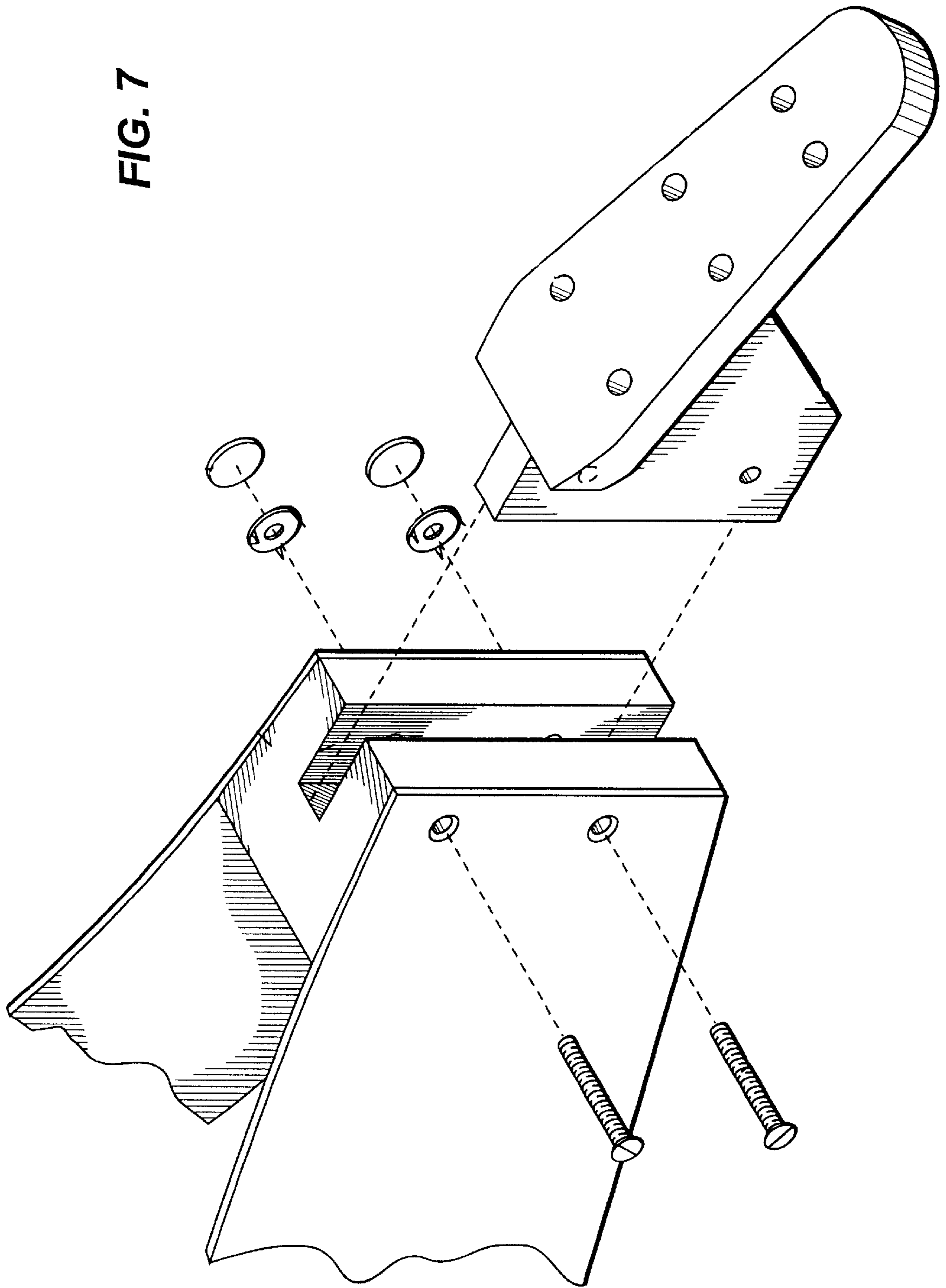

FIG. 8

