



US00D488744S

(12) **United States Design Patent**
Ciarfello

(10) **Patent No.:** **US D488,744 S**

(45) **Date of Patent:** **** Apr. 20, 2004**

(54) **SLIDE OUT UNITS FOR A RECREATIONAL VEHICLE**

(76) **Inventor:** **Timothy L. Ciarfello**, 1902 Woodbrook Dr., Wilmington, DE (US) 19810

(**) **Term:** **14 Years**

(21) **Appl. No.:** **29/178,362**

(22) **Filed:** **Mar. 26, 2003**

(51) **LOC (7) Cl.** **12-10**

(52) **U.S. Cl.** **D12/104**

(58) **Field of Search** D12/104; 296/26.01, 296/26.03, 26.13, 165, 171, 175, 26.12; 52/67

(56) **References Cited**

U.S. PATENT DOCUMENTS

3,887,226	A	*	6/1975	Hart	296/26.11
D241,027	S	*	8/1976	Cox	D12/104
D255,027	S	*	5/1980	Hemminger	D12/403
D274,844	S	*	7/1984	Corey	D25/22
6,224,126	B1	*	5/2001	Martin et al.	296/26.01
6,325,437	B2	*	12/2001	Hiebert et al.	296/26.01

6,354,646	B1	*	3/2002	McManus et al.	296/26.13
6,402,216	B1	*	6/2002	McManus et al.	296/26.14
6,536,821	B1	*	3/2003	Gardner	296/26.01
6,575,514	B2	*	6/2003	McManus et al.	296/26.01
6,619,713	B2	*	9/2003	Eichhorn	296/26.01

* cited by examiner

Primary Examiner—Melody N. Brown

(57) **CLAIM**

The ornamental design for slide out units for a recreational vehicle, as shown and described.

DESCRIPTION

FIG. 1 is a perspective view of slide out units for a recreational vehicle.

FIG. 2 is a top plan view.

FIG. 3 is a side elevational view.

FIG. 4 is a front elevational view; and,

FIG. 5 is a rear elevational view.

The broken lines shown the vehicle throughout the drawing views are for illustrative purposes only and form no part of the claimed design.

1 Claim, 3 Drawing Sheets

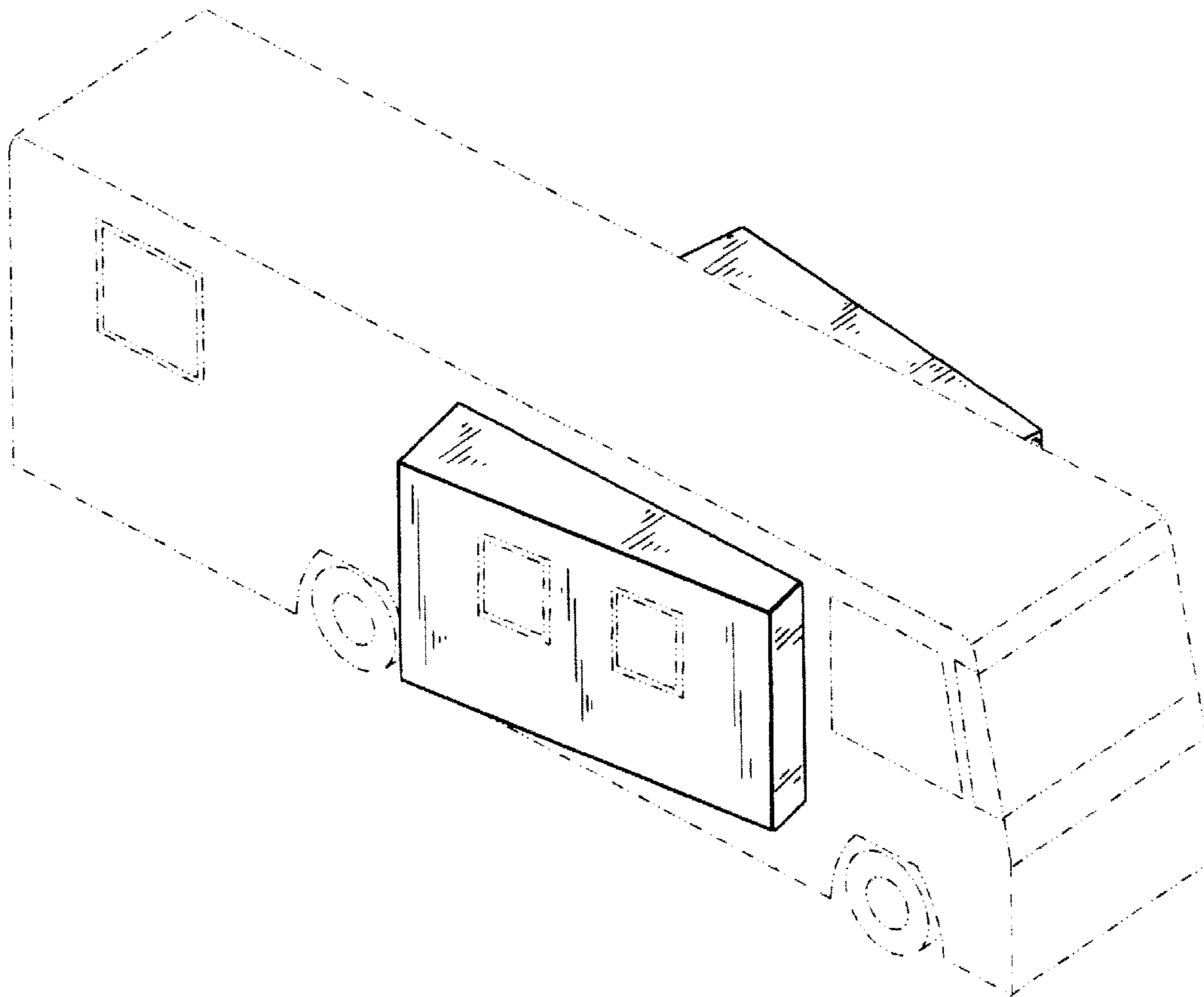

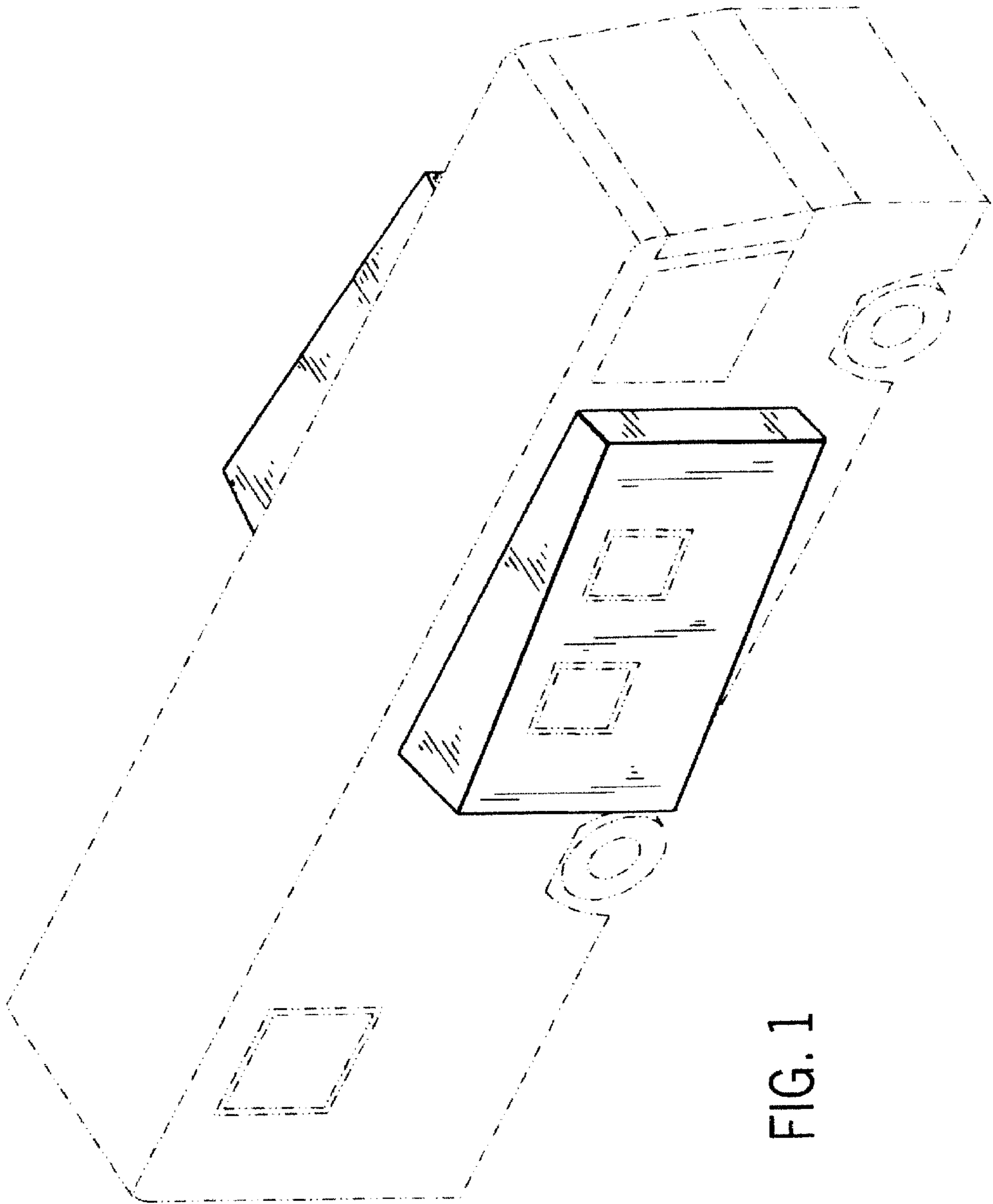

FIG. 1

FIG. 2

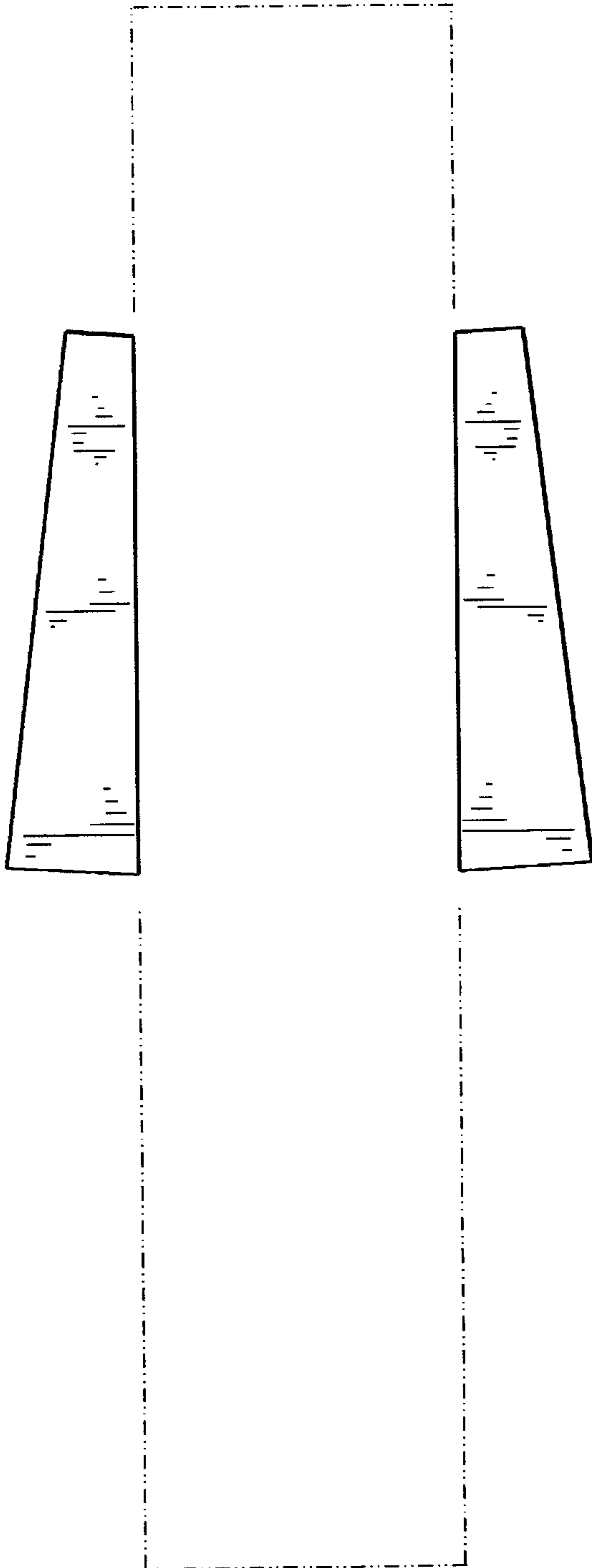
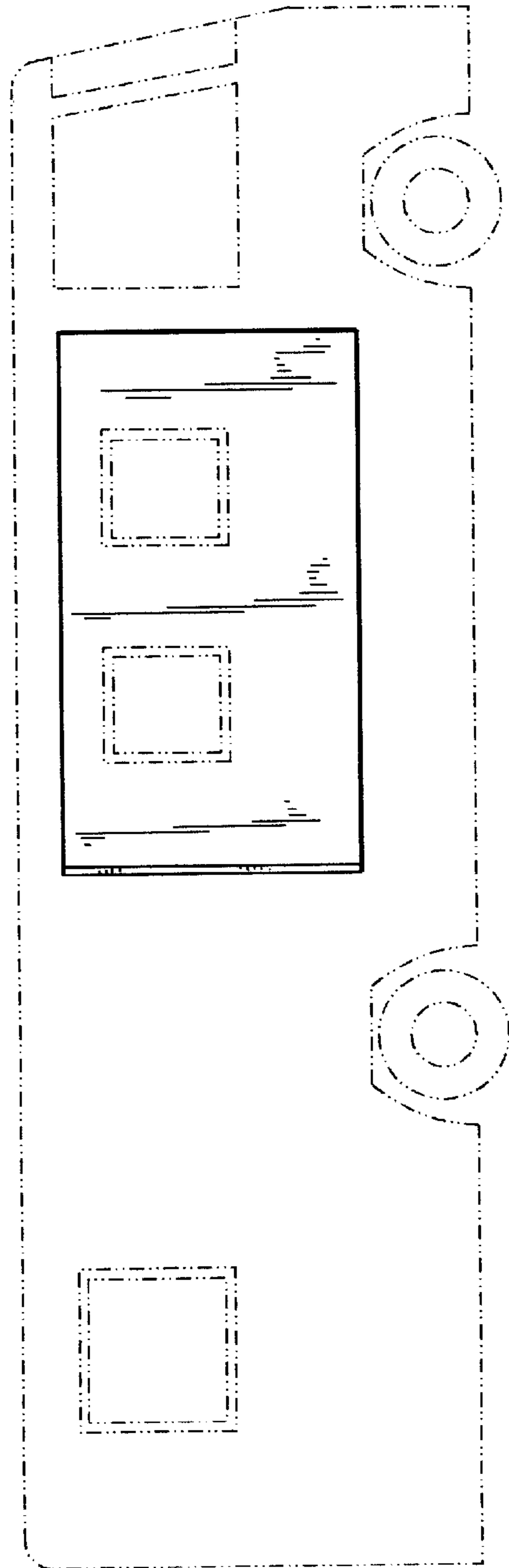

FIG. 3



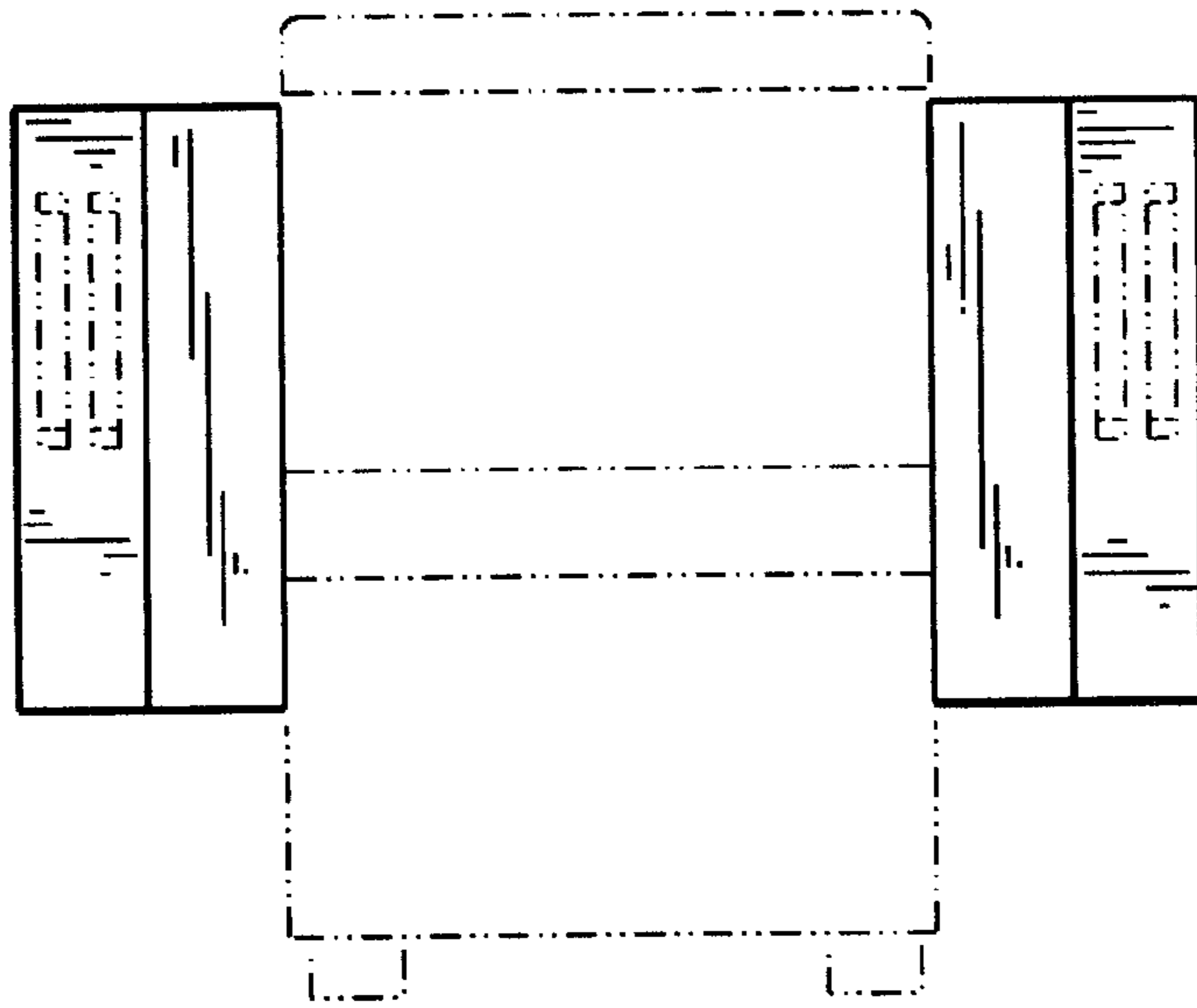

FIG. 4

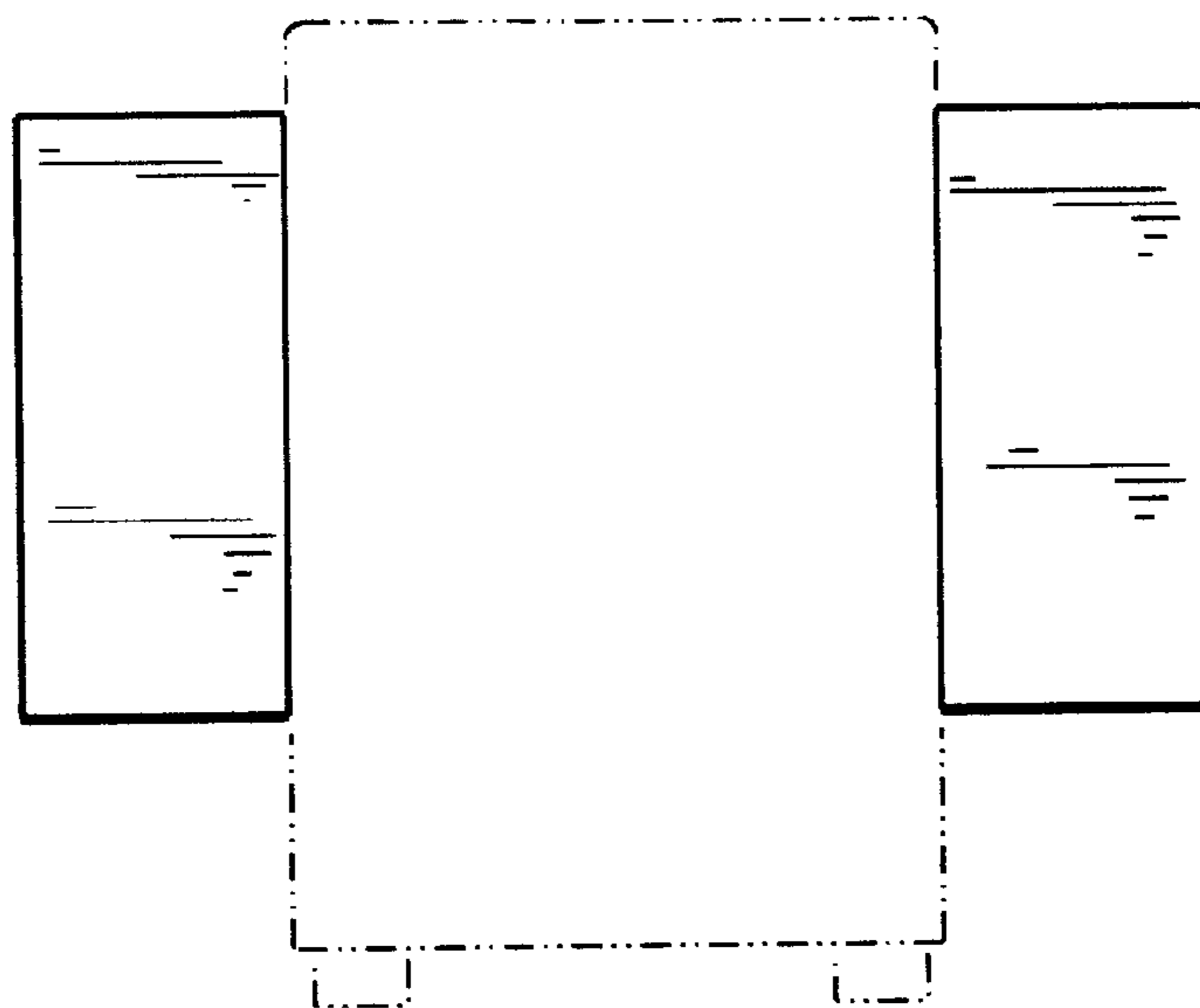

FIG. 5