



US00D488629S

(12) **United States Design Patent**  
**Giasson**

(10) **Patent No.:** **US D488,629 S**

(45) **Date of Patent:** **\*\* Apr. 20, 2004**

(54) **SEAT FOR AIRCRAFT**

(75) Inventor: **Brigitte Giasson**, Outremont (CA)

(73) Assignee: **3861589 Canada Inc.**, Outremont (CA)

(\*\*) Term: **14 Years**

(21) Appl. No.: **29/180,676**

(22) Filed: **Apr. 30, 2003**

(30) **Foreign Application Priority Data**

Apr. 17, 2003 (CA) ..... 102779  
Apr. 29, 2003 (CA) ..... 102880

(51) **LOC (7) Cl.** ..... **06-01**

(52) **U.S. Cl.** ..... **D6/356**

(58) **Field of Search** ..... D6/334, 335, 336,  
D6/356, 360, 361, 367, 500-502; 297/188.01,  
188.14, 188.18, 232, 244, 391, 396; 244/118.5,  
118.6

(56) **References Cited**

**U.S. PATENT DOCUMENTS**

|             |   |         |                    |       |         |
|-------------|---|---------|--------------------|-------|---------|
| D153,875 S  | * | 5/1949  | Hager              | ..... | D6/356  |
| D201,129 S  | * | 5/1965  | Solomon            | ..... | D6/360  |
| D262,165 S  | * | 12/1981 | Andries et al.     | ..... | D6/335  |
| D269,652 S  | * | 7/1983  | McKean et al.      | ..... | D6/361  |
| D273,157 S  | * | 3/1984  | Staub              | ..... | D6/356  |
| D409,010 S  | * | 5/1999  | Papaioannou et al. | ..... | D6/356  |
| 6,158,812 A | * | 12/2000 | Bonke              | ..... | 297/391 |
| D443,990 S  | * | 6/2001  | Beroth             | ..... | D6/356  |
| D456,621 S  | * | 5/2002  | Antunes et al.     | ..... | D6/367  |

\* cited by examiner

*Primary Examiner*—Doris V. Coles

*Assistant Examiner*—Mimosa De

(74) *Attorney, Agent, or Firm*—Brouillette Kosie Prince

(57) **CLAIM**

The ornamental design for a seat for aircraft, as shown.

**DESCRIPTION**

FIG. 1 is a front elevational view of a first embodiment of the seat for aircraft;

FIG. 2 is a rear elevational view of the first embodiment of the seat for aircraft;

FIG. 3 is a right side elevational view of the first embodiment of the seat for aircraft;

FIG. 4 is a left side elevational view of the first embodiment of the seat for aircraft;

FIG. 5 is a top plan view of the first embodiment of the seat for aircraft;

FIG. 6 is a front elevational view of the second embodiment of the seat for aircraft;

FIG. 7 is a rear elevational view of the second embodiment of the seat for aircraft;

FIG. 8 is a left side elevational view of the second embodiment of the seat for aircraft;

FIG. 9 is a right side elevational view of the second embodiment of the seat for aircraft; and,

FIG. 10 is a top plan view of the second embodiment of the seat for aircraft.

**1 Claim, 6 Drawing Sheets**

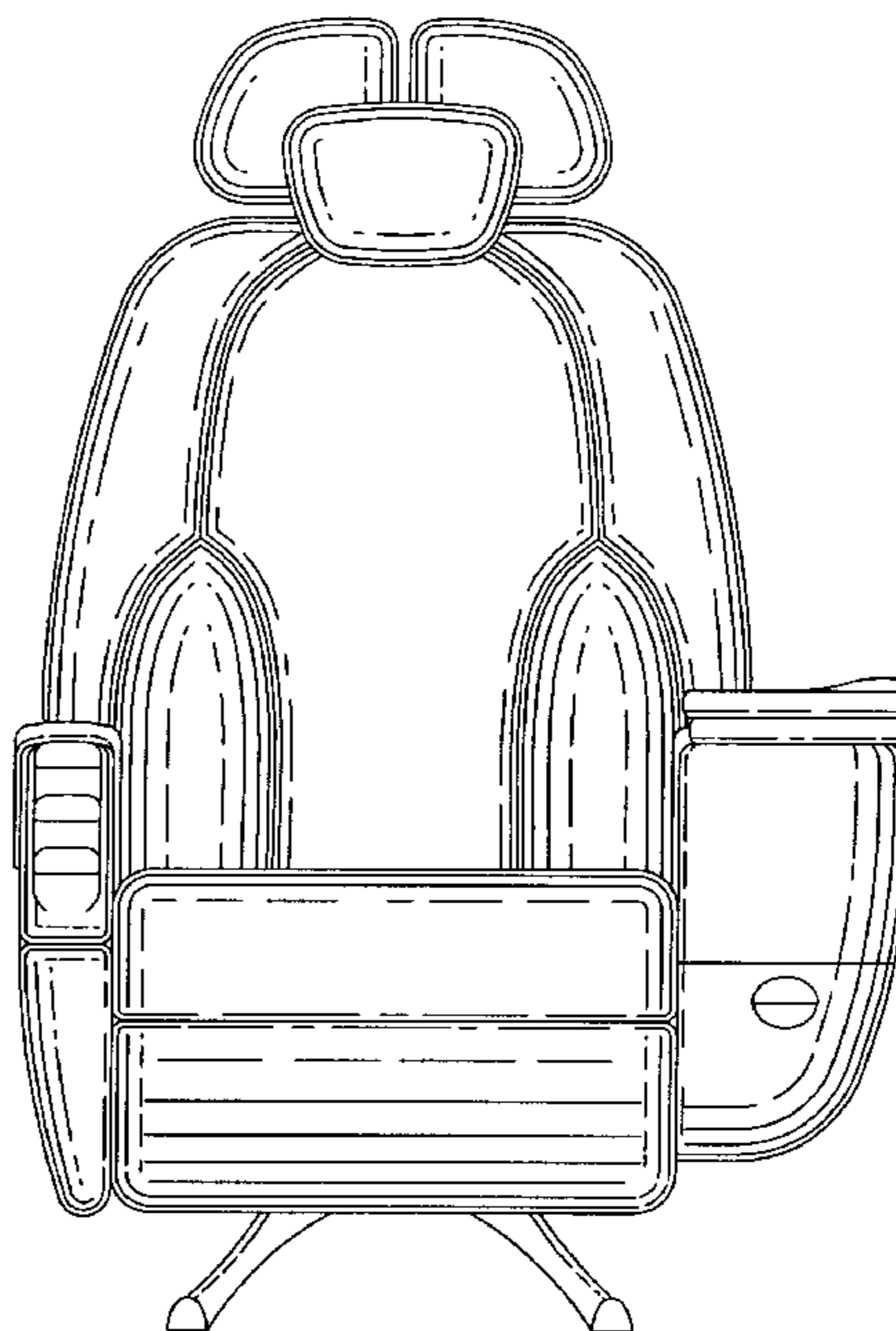
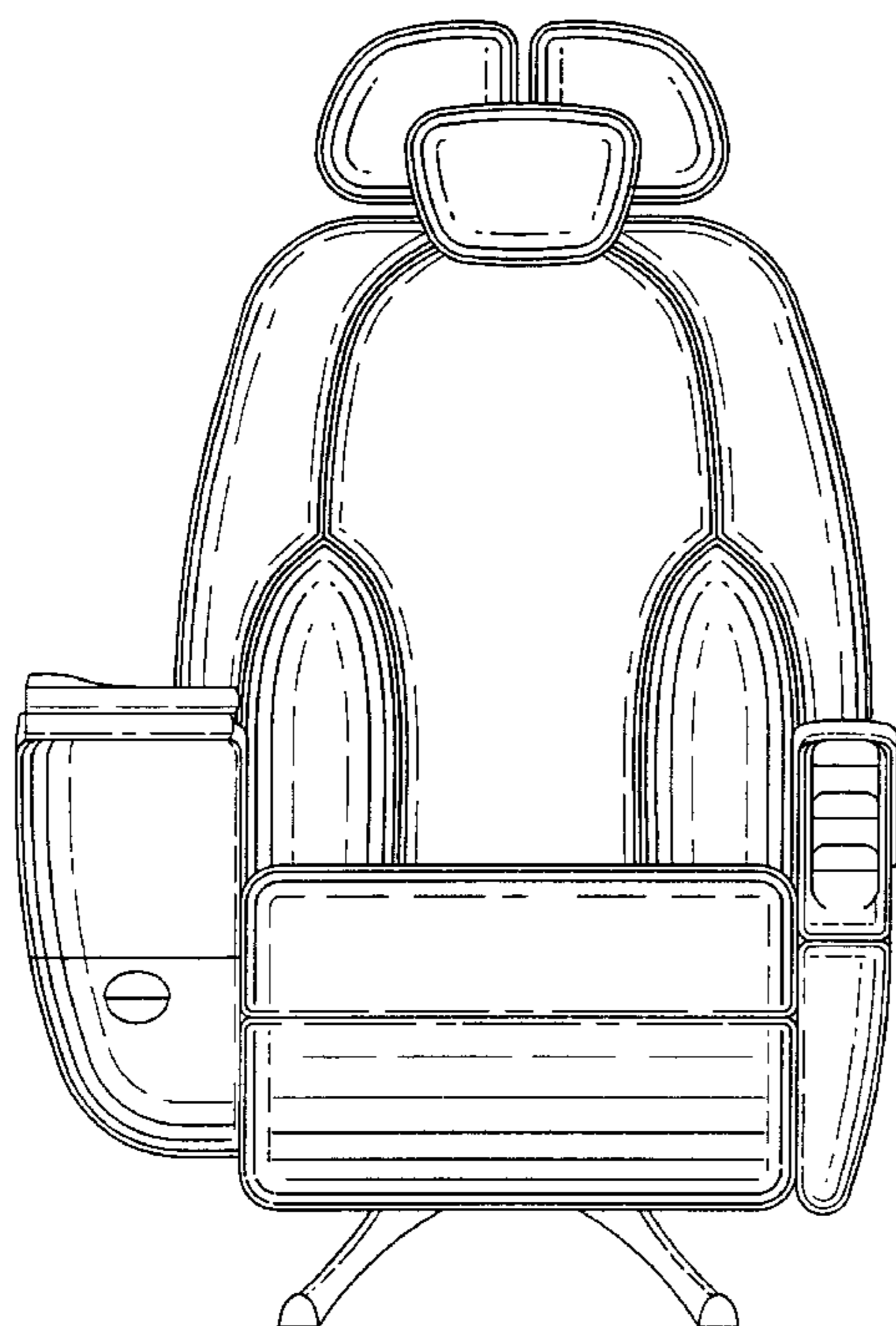

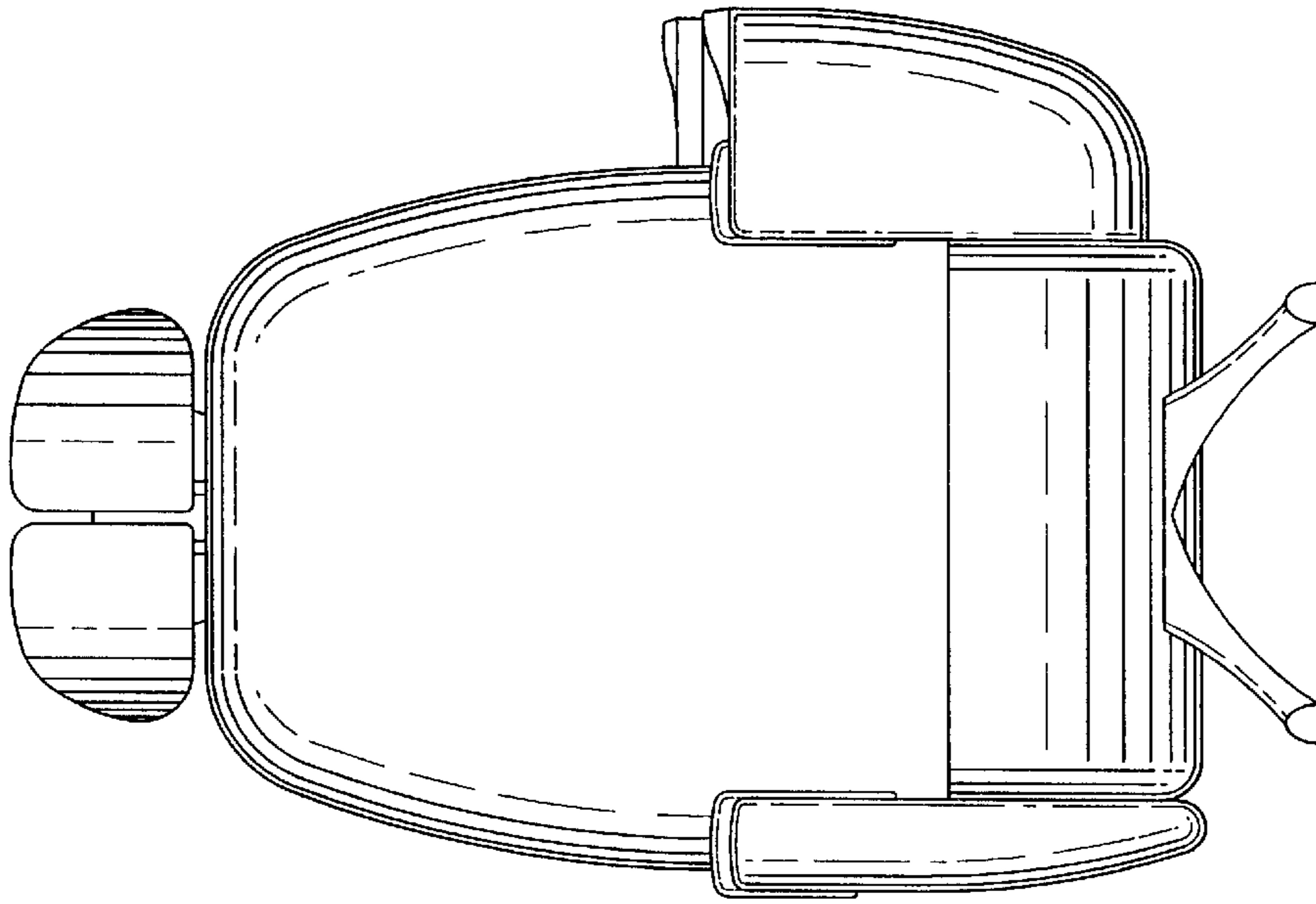

FIG. 2

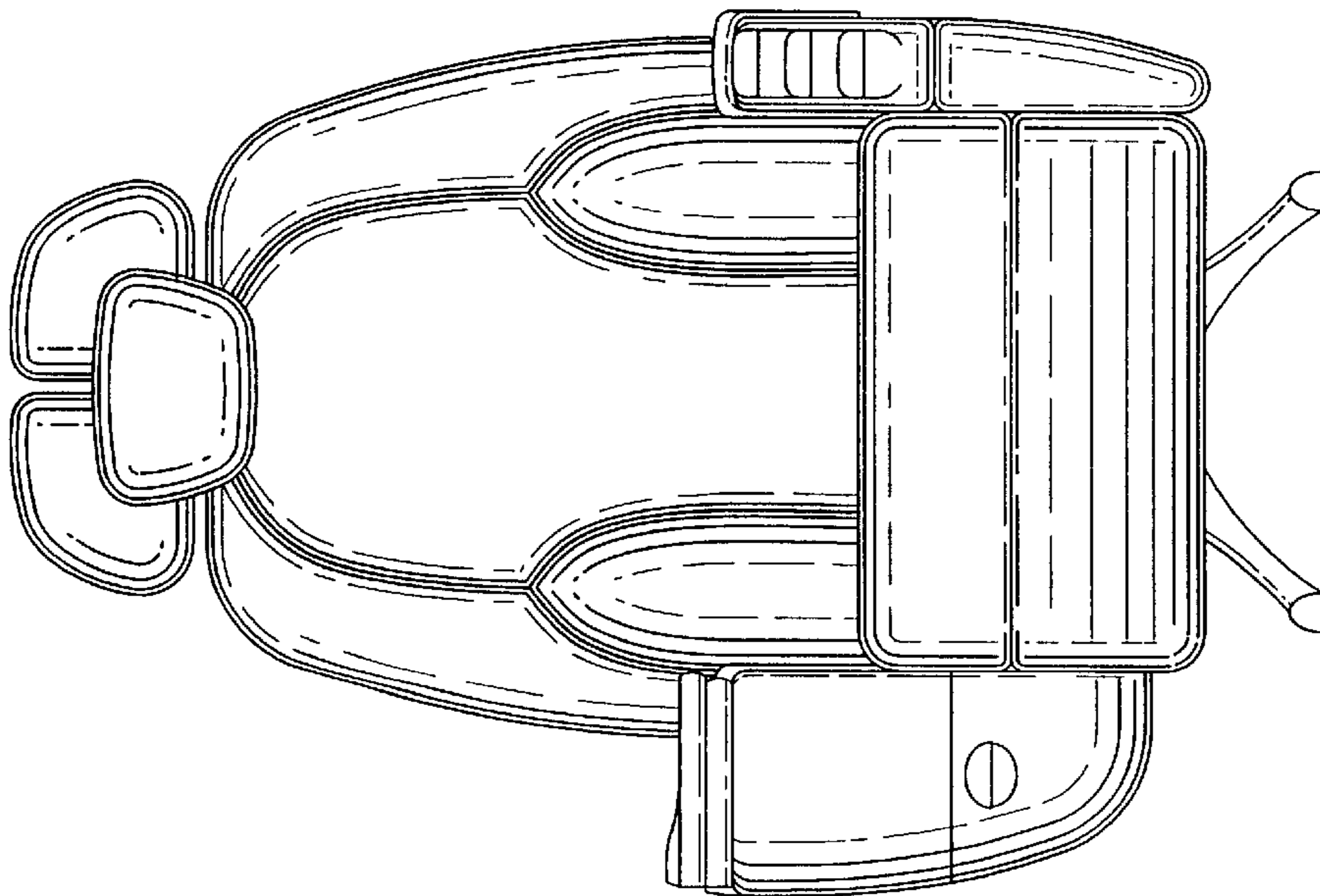

FIG. 1

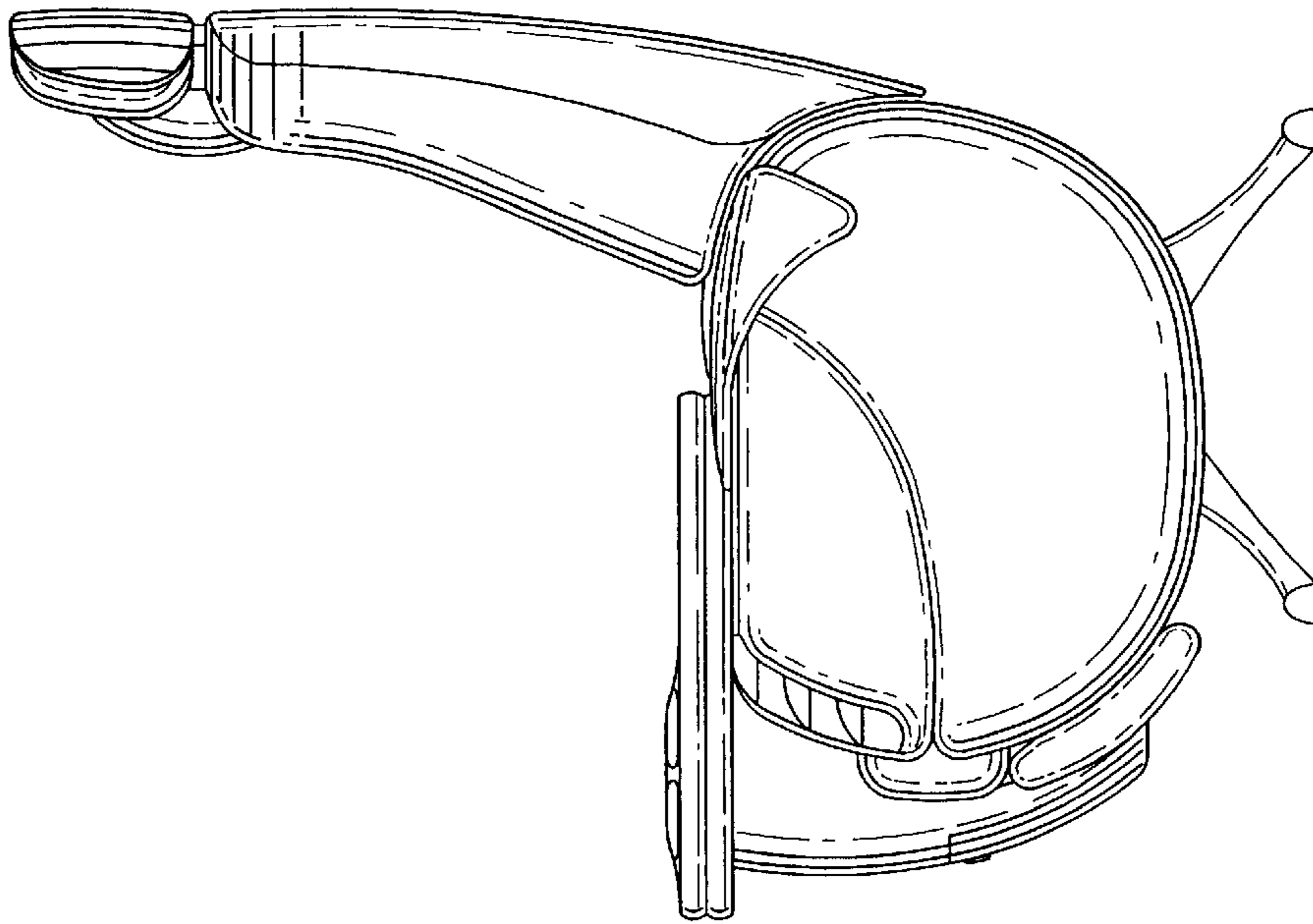

FIG. 4

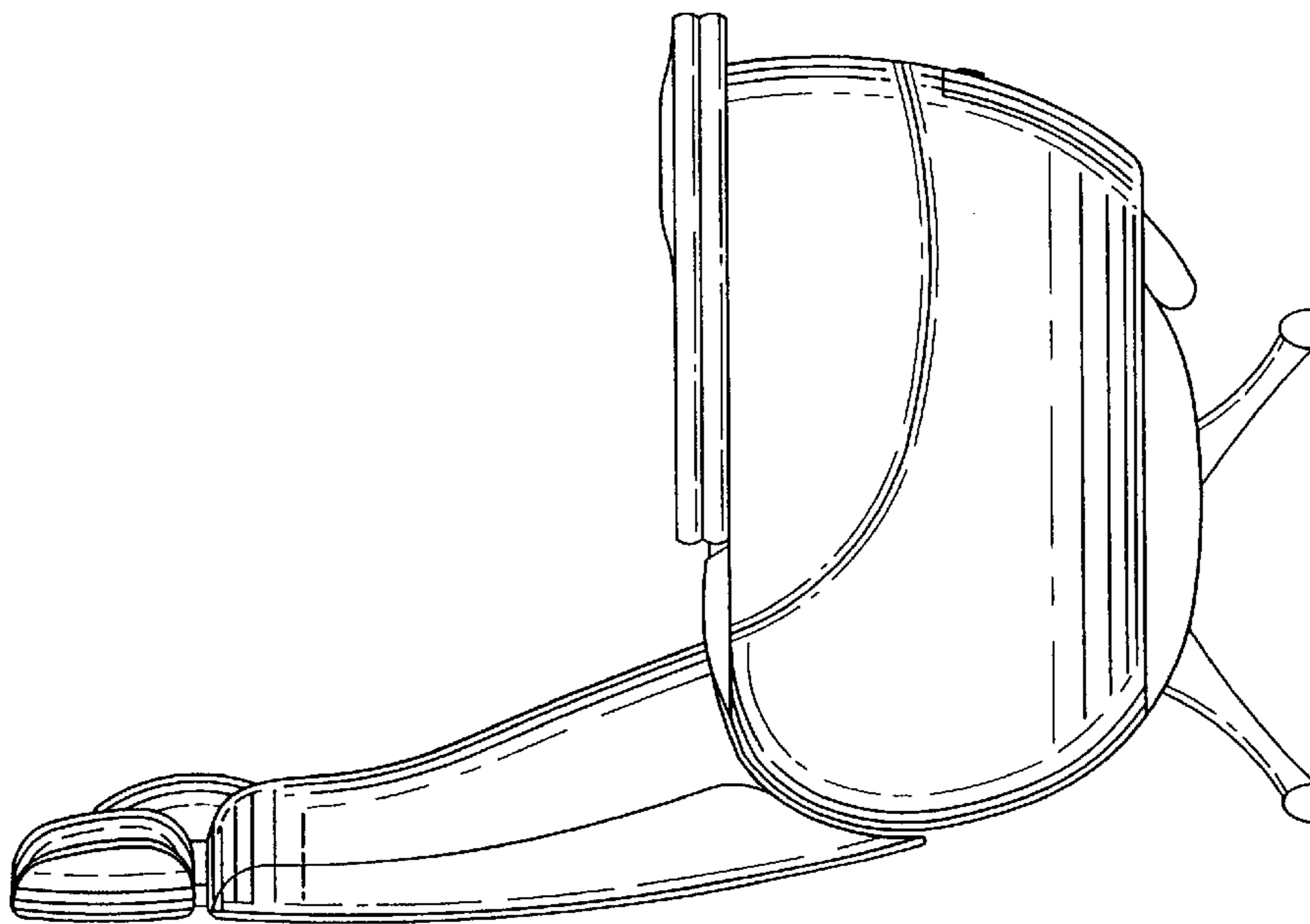

FIG. 3

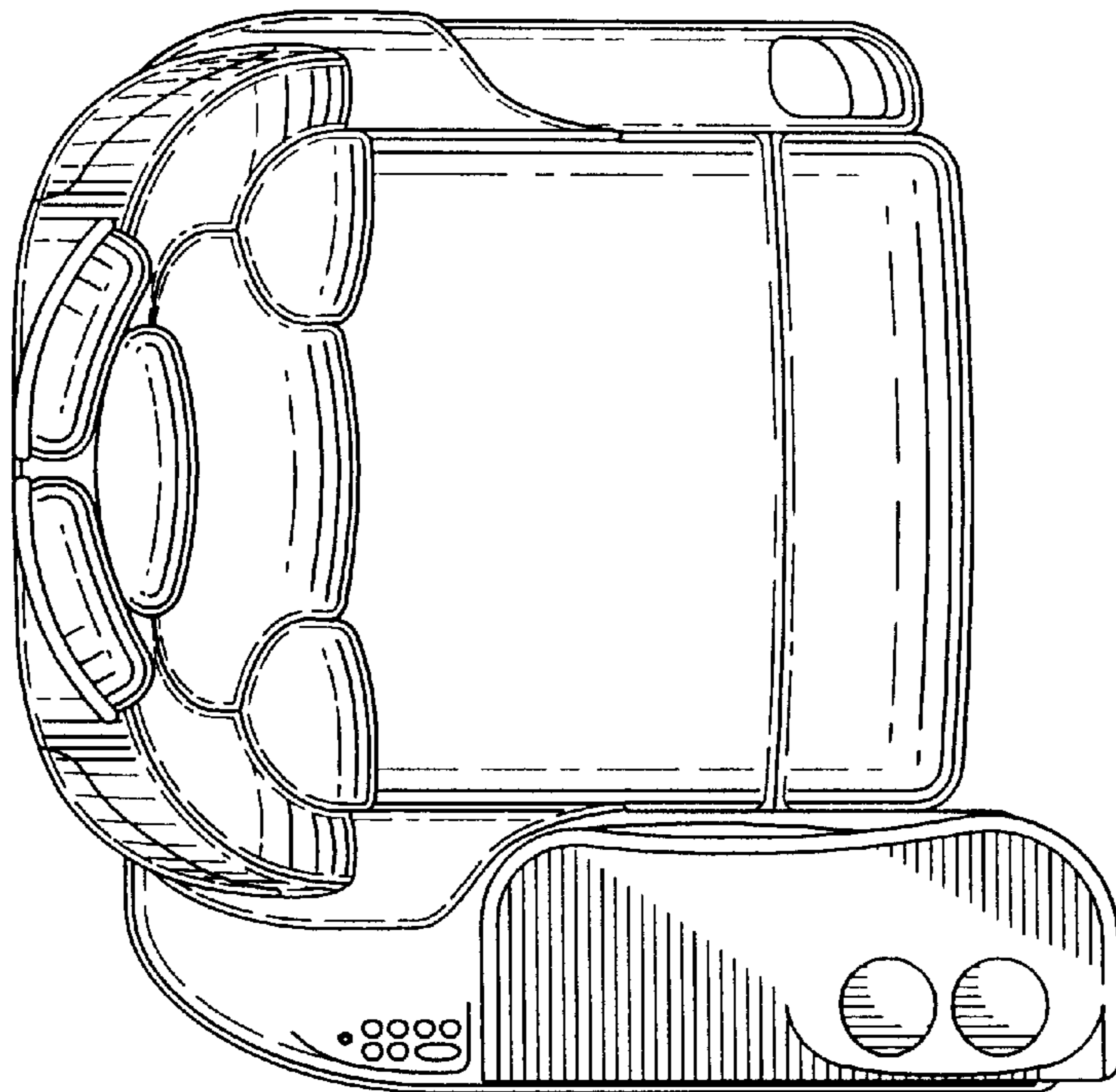

FIG. 5

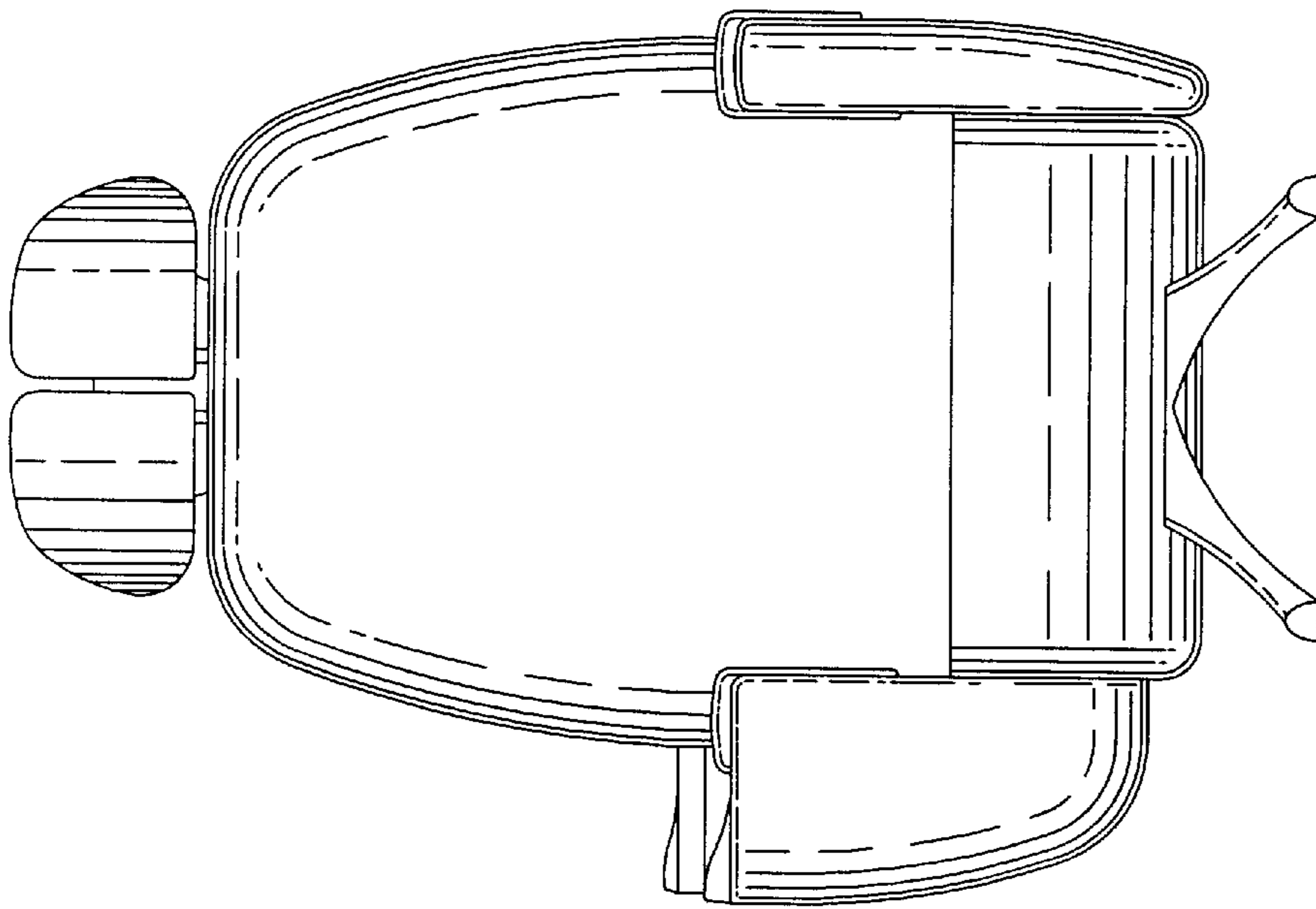

FIG. 7

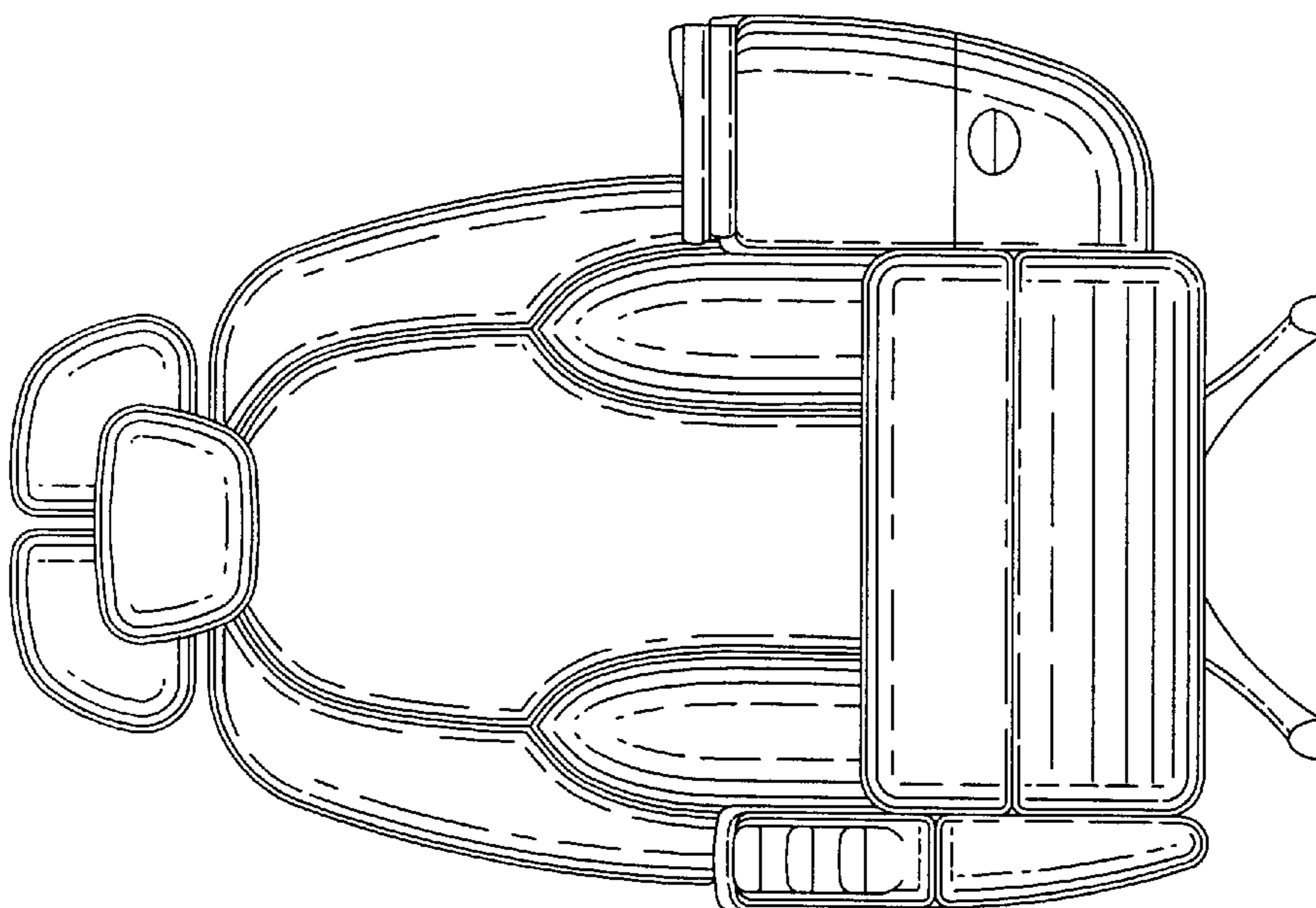

FIG. 8

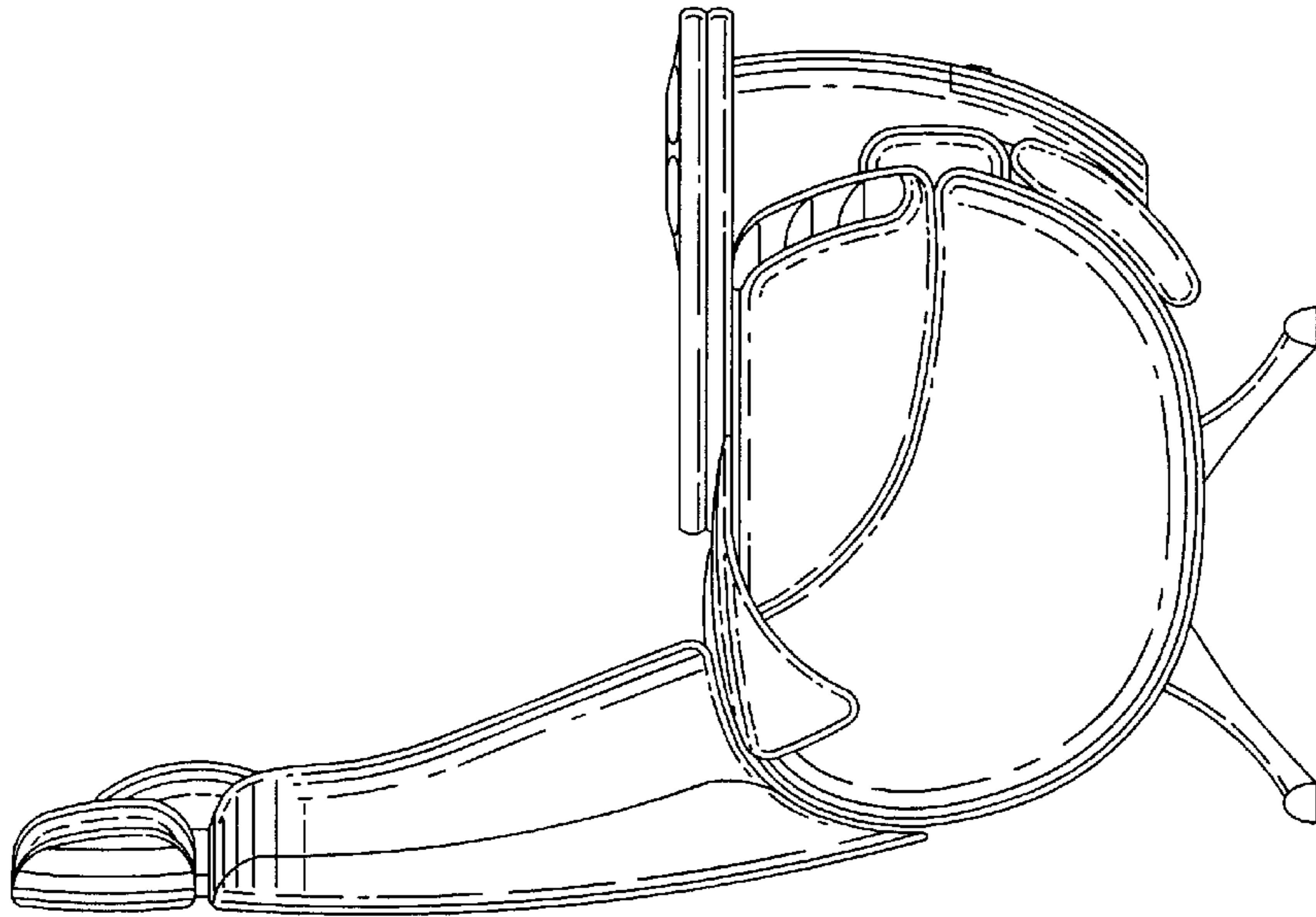

FIG. 1

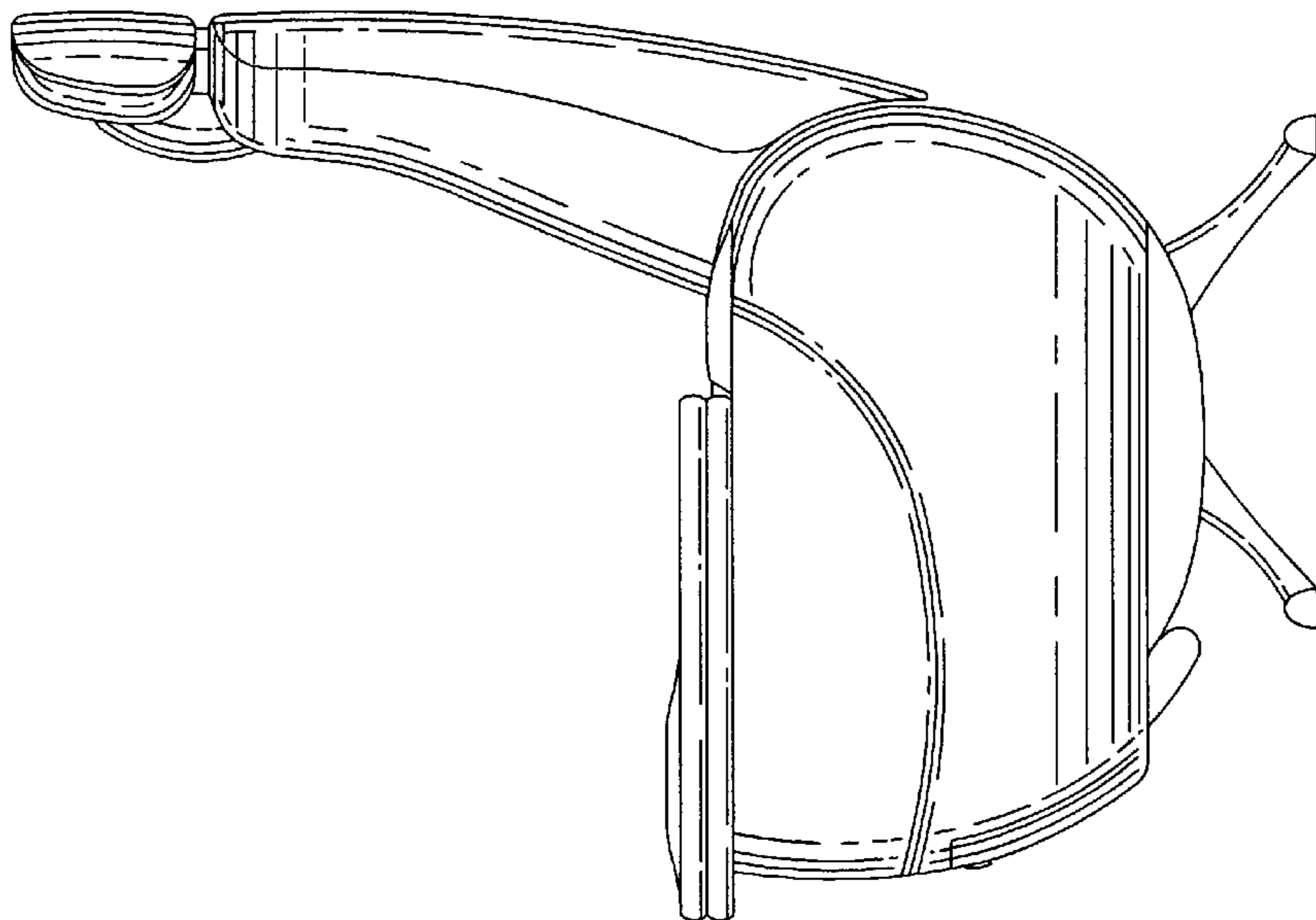

FIG. 2

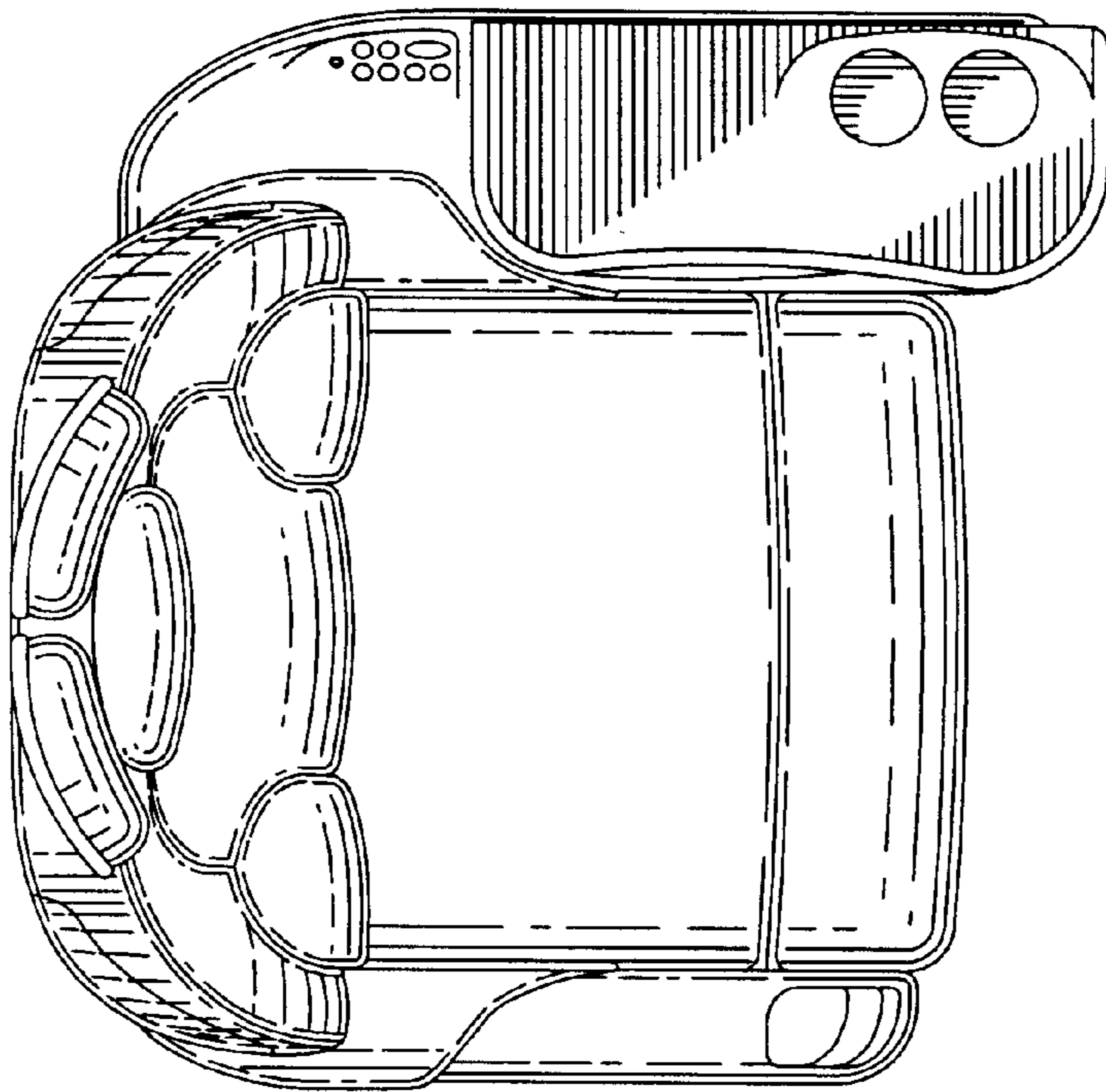

FIG. 10