



US00D488424S

(12) **United States Design Patent**  
**Pigeon**

(10) **Patent No.:** **US D488,424 S**

(45) **Date of Patent:** **\*\* Apr. 13, 2004**

(54) **BOAT HULL**

(75) Inventor: **Charles F. Pigeon**, Abilene, TX (US)

(73) Assignee: **Tige Boats, Inc.**, Abilene, TX (US)

(\*\*) Term: **14 Years**

(21) Appl. No.: **29/185,392**

(22) Filed: **Jun. 26, 2003**

(51) **LOC (7) Cl.** ..... **12-06**

(52) **U.S. Cl.** ..... **D12/300**

(58) **Field of Search** ..... D12/300-318;  
114/56, 288.1, 292, 344

(56) **References Cited**

**U.S. PATENT DOCUMENTS**

D331,561 S \* 12/1992 Stark ..... D12/300

\* cited by examiner

*Primary Examiner*—Lisa Lichtenstein

(74) *Attorney, Agent, or Firm*—Haynes and Boone, LLP.

(57) **CLAIM**

The design for the boat hull, as shown and described.

**DESCRIPTION**

FIG. 1 is a side elevational view of my new design;

FIG. 2 is a front elevational view;

FIG. 3 is a rear elevational view thereof; and,

FIG. 4 is a bottom elevational view of my new design.

The broken line showing of environmental structure is for illustrative purposes only and forms no part of the claimed design.

**1 Claim, 2 Drawing Sheets**

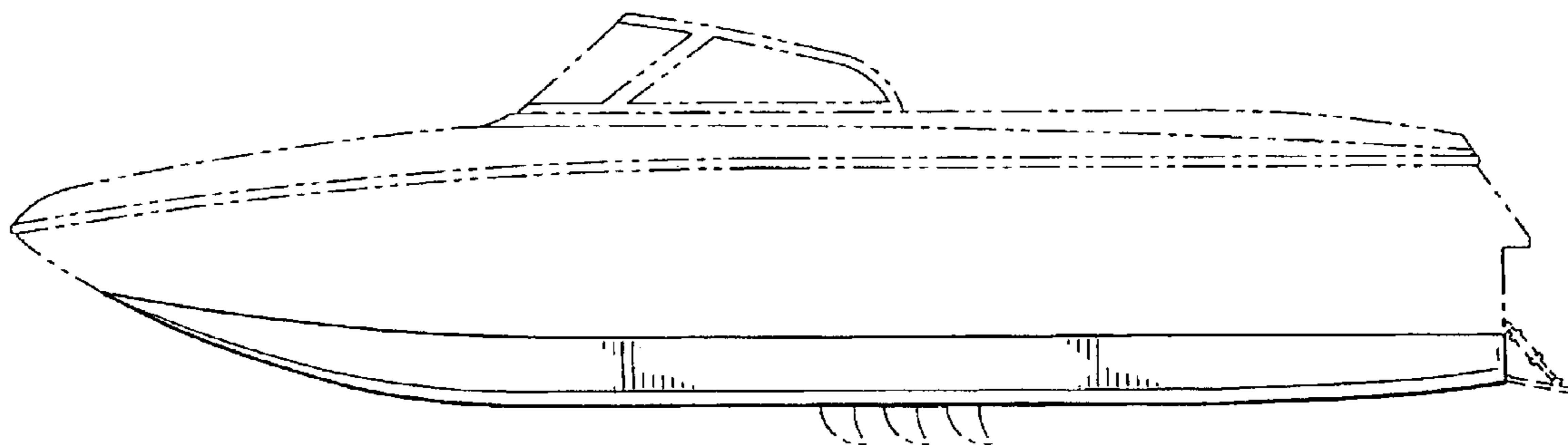

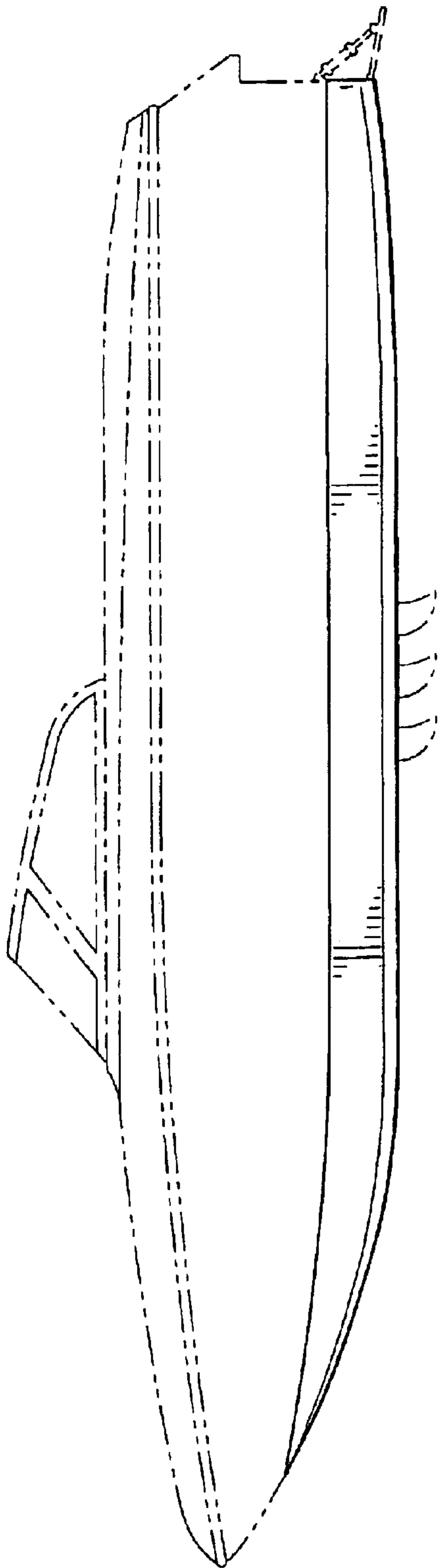

Fig. 1

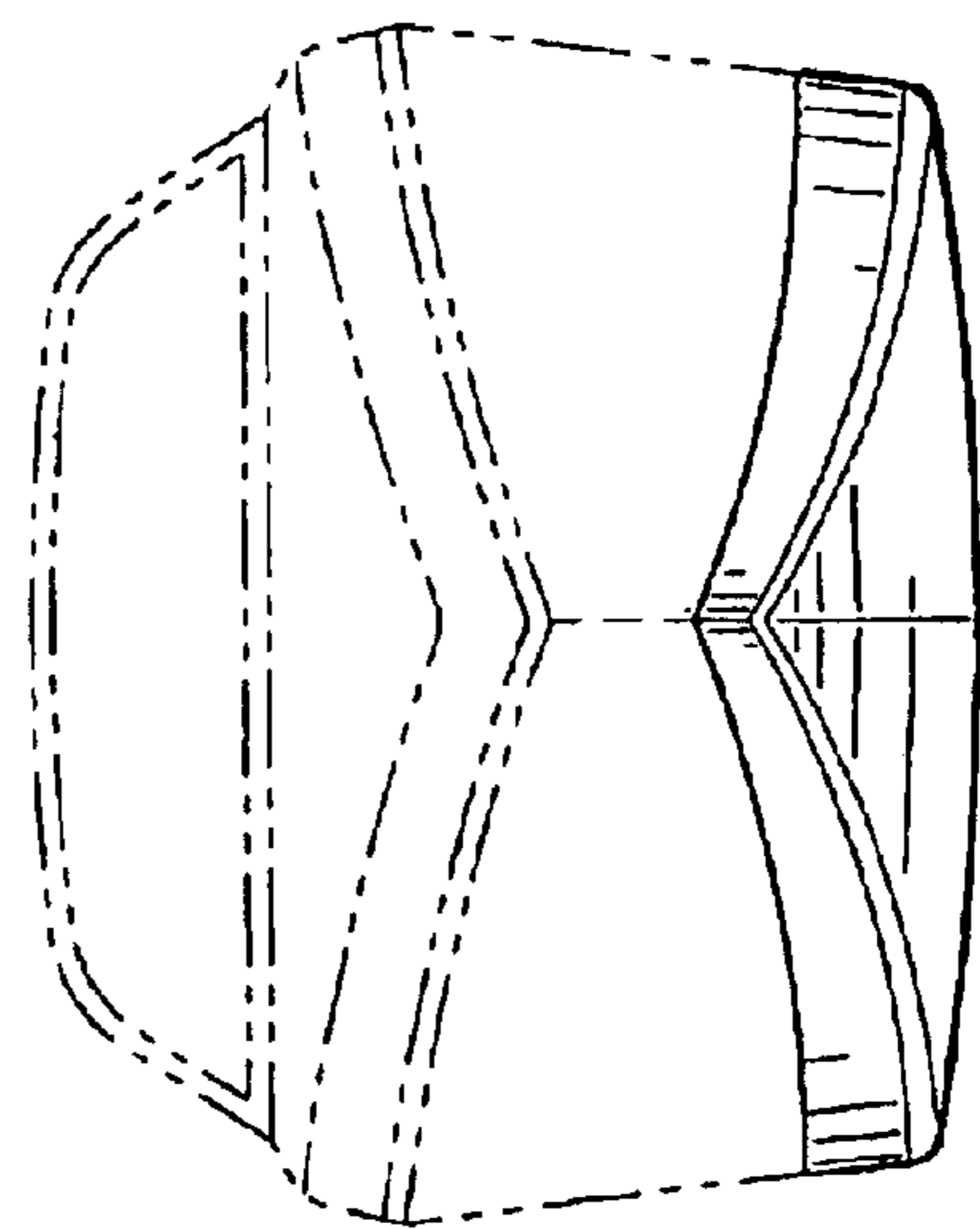

Fig. 2

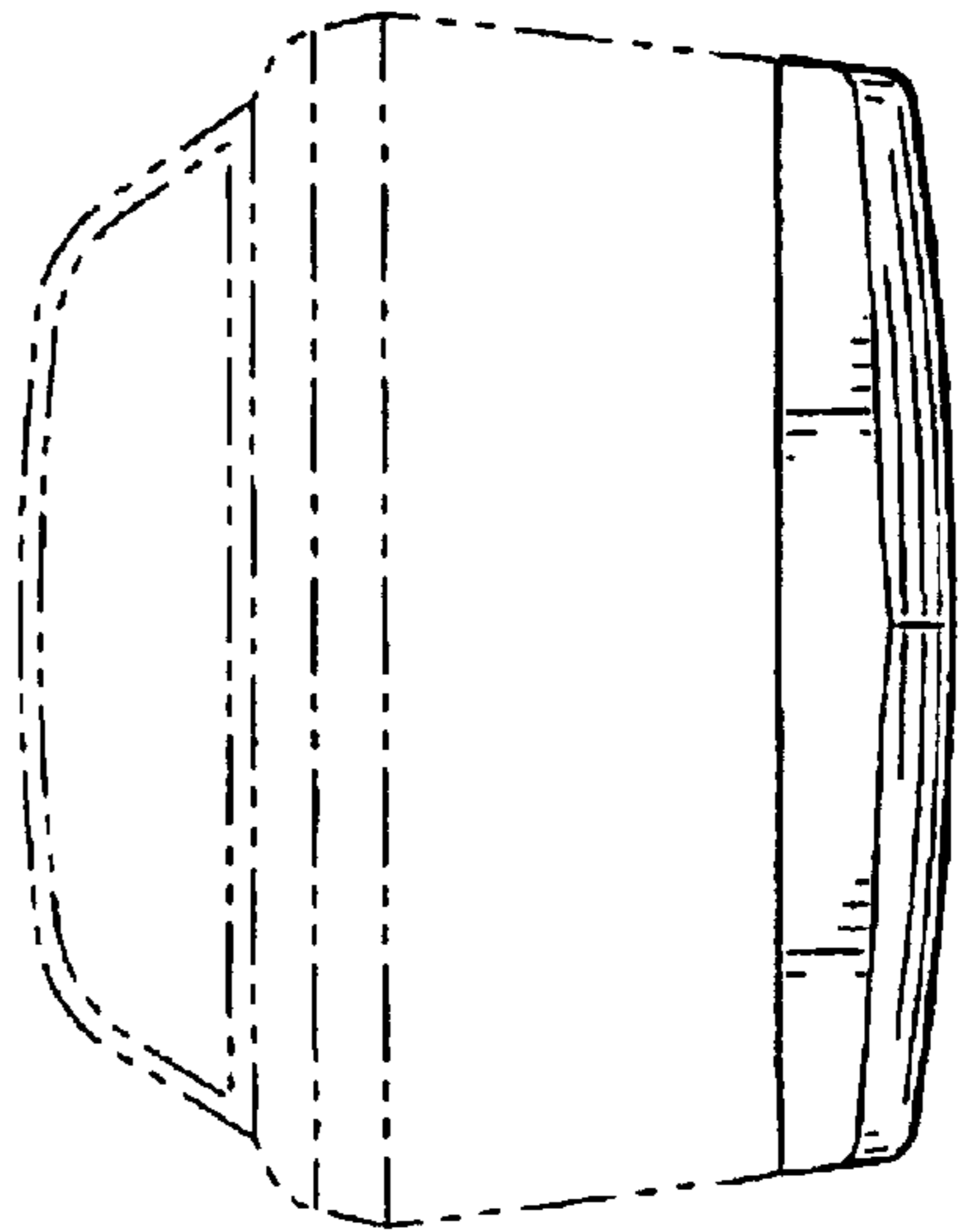

Fig. 3

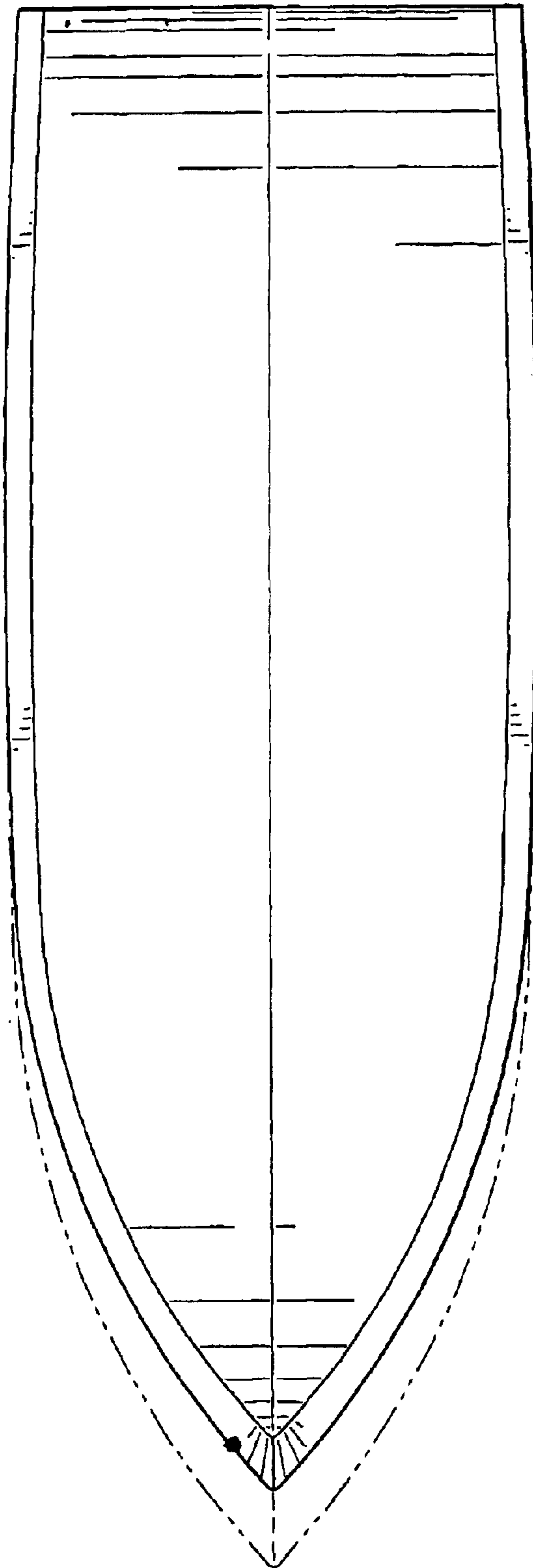

Fig. 4