



US00D488414S

(12) **United States Design Patent**
Barbosa et al.

(10) **Patent No.:** **US D488,414 S**

(45) **Date of Patent:** **** Apr. 13, 2004**

(54) **OPENING IN A BRAKE CALIPER**
(75) Inventors: **Manuel Barbosa**, Novi, MI (US); **Sean C. Barrett**, Farmington Hills, MI (US); **Philip N. Jedele**, Plymouth, MI (US)

(73) Assignee: **Akebono Corporation (North America)**, Farmington Hills, MI (US)

(**) Term: **14 Years**

(21) Appl. No.: **29/178,274**

(22) Filed: **Mar. 24, 2003**

(51) **LOC (7) Cl.** **12-16**

(52) **U.S. Cl.** **D12/180**

(58) **Field of Search** D12/180; 188/73.31,
188/73.34, 73.3, 73.43, 218 XL

(56) **References Cited**

U.S. PATENT DOCUMENTS

3,884,332 A	5/1975	Walther et al.	188/73.4
4,200,173 A	4/1980	Evans et al.	188/73.3
4,485,897 A	12/1984	Kawaguchi et al.	188/73.39
4,805,745 A	2/1989	Thiel	188/73.31
4,878,564 A	11/1989	Kondo	188/73.31
5,022,500 A	6/1991	Wang	188/73.31
5,205,383 A	4/1993	Terashima	188/73.45
5,249,649 A	10/1993	Emmons	188/73.47
5,363,944 A	11/1994	Thiel et al.	188/73.31
5,464,077 A	11/1995	Thiel et al.	188/72.5
D378,363 S	3/1997	Sin	D12/180

D425,465 S	*	5/2000	Pink et al.	D12/180
D426,180 S	*	6/2000	Pink et al.	D12/180
6,131,706 A		10/2000	Gotti et al.	188/72.4
6,478,121 B2		11/2002	Reeves	188/73.31
D476,275 S	*	6/2003	Winkler et al.	D12/180
2001/0013448 A1		8/2001	Schorn et al.	
2001/0032757 A1		10/2001	Ballinger et al.	
2002/0014376 A1		2/2002	Ortegren et al.	
2002/0017436 A1		2/2002	Ortegren et al.	

FOREIGN PATENT DOCUMENTS

JP 55-135237 10/1980

* cited by examiner

Primary Examiner—Melody N. Brown

(74) *Attorney, Agent, or Firm*—Harness, Dickey & Pierce, P.L.C.

(57) **CLAIM**

The ornamental design for an opening in a brake caliper, substantially as shown and described.

DESCRIPTION

FIG. 1 is a perspective view of an opening of a brake caliper in accordance with the present invention.

FIG. 2 is a front elevational view of FIG. 1.

FIG. 3 is a side elevational view of FIG. 1; and,

FIG. 4 is a top plan view of FIG. 1.

The broken lines are for illustrative purposes only and form no part of the claimed design.

1 Claim, 2 Drawing Sheets

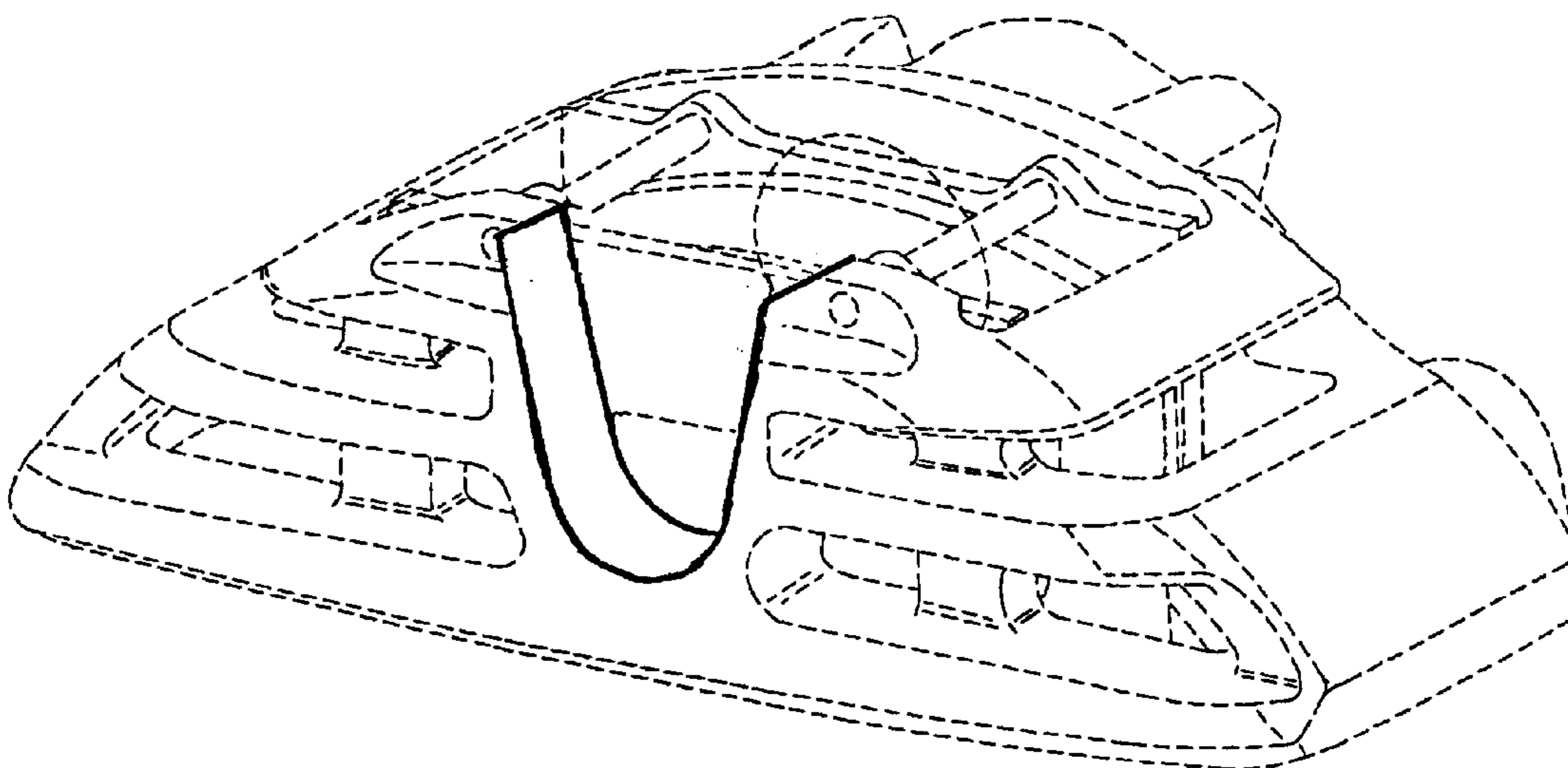

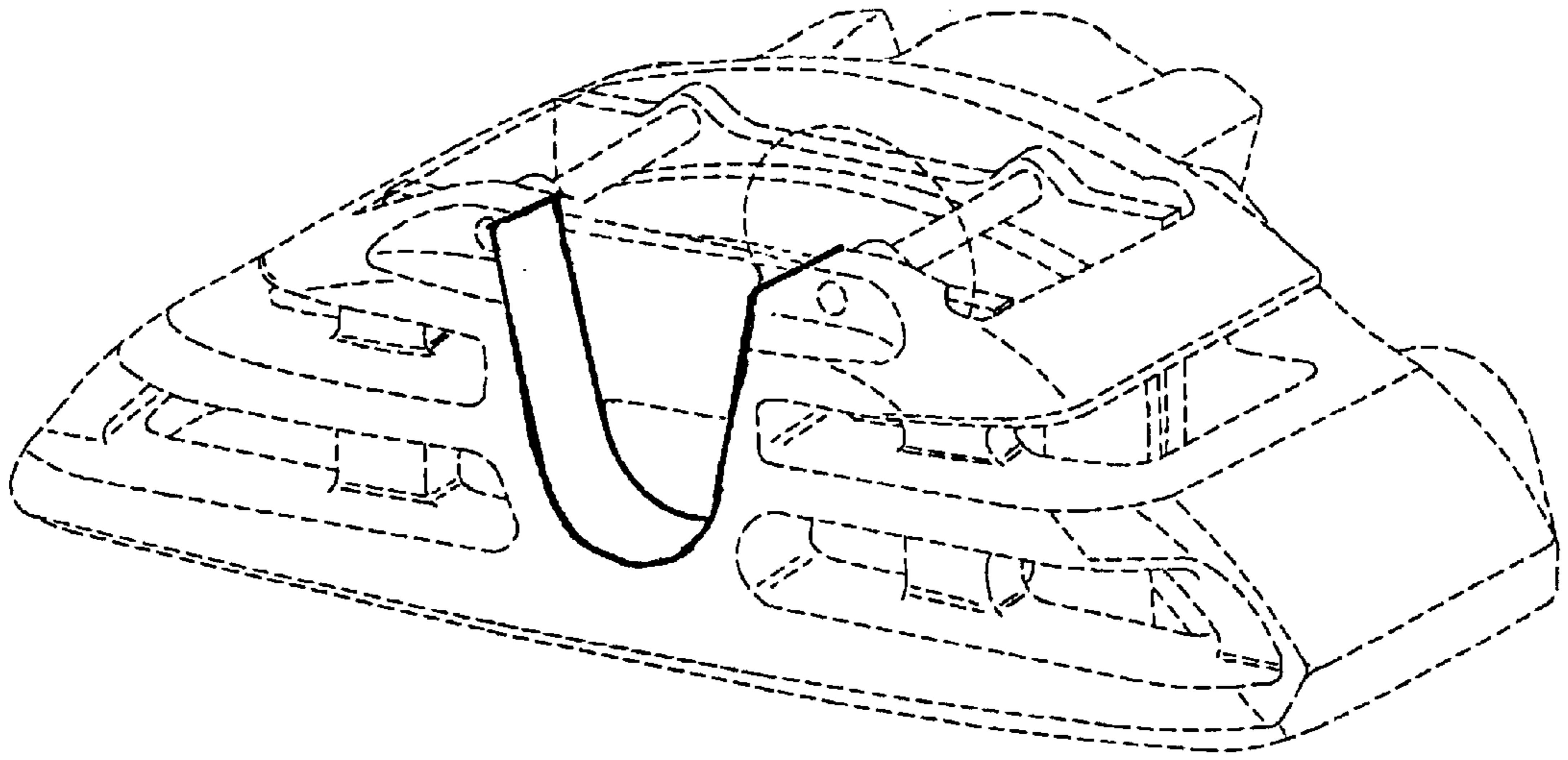

FIG - 1

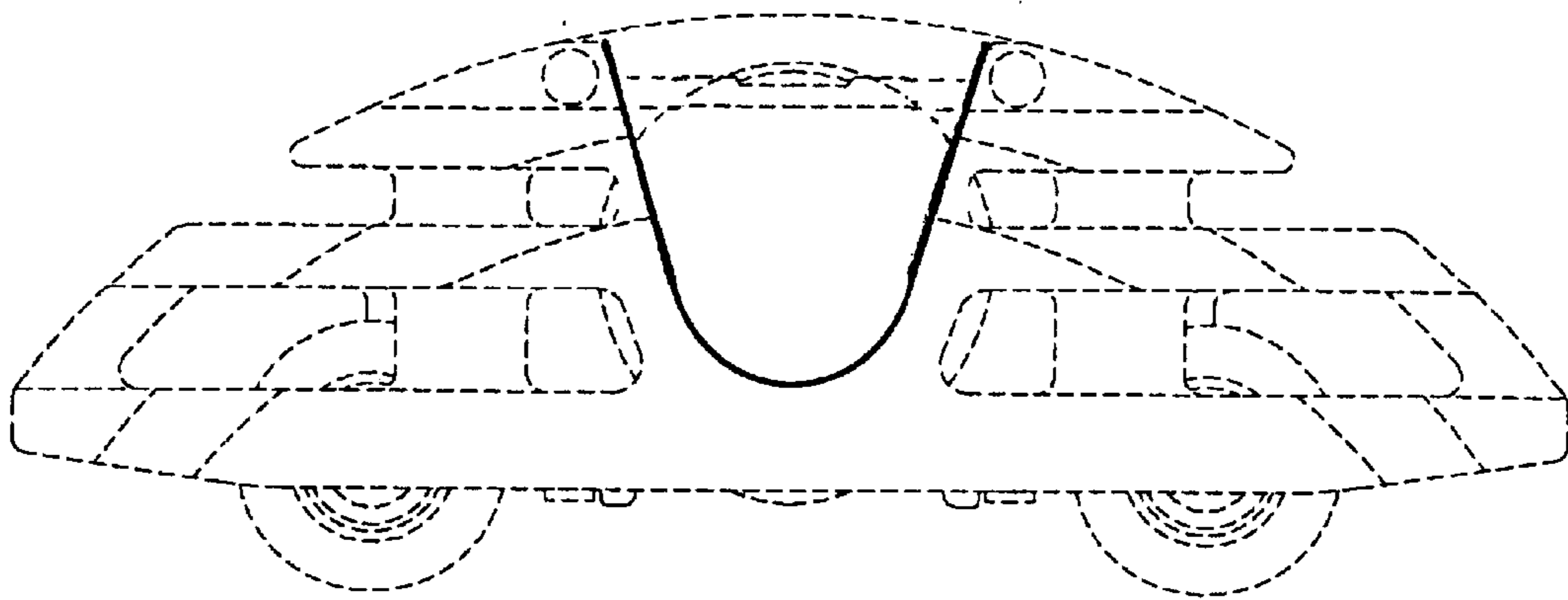

FIG - 2

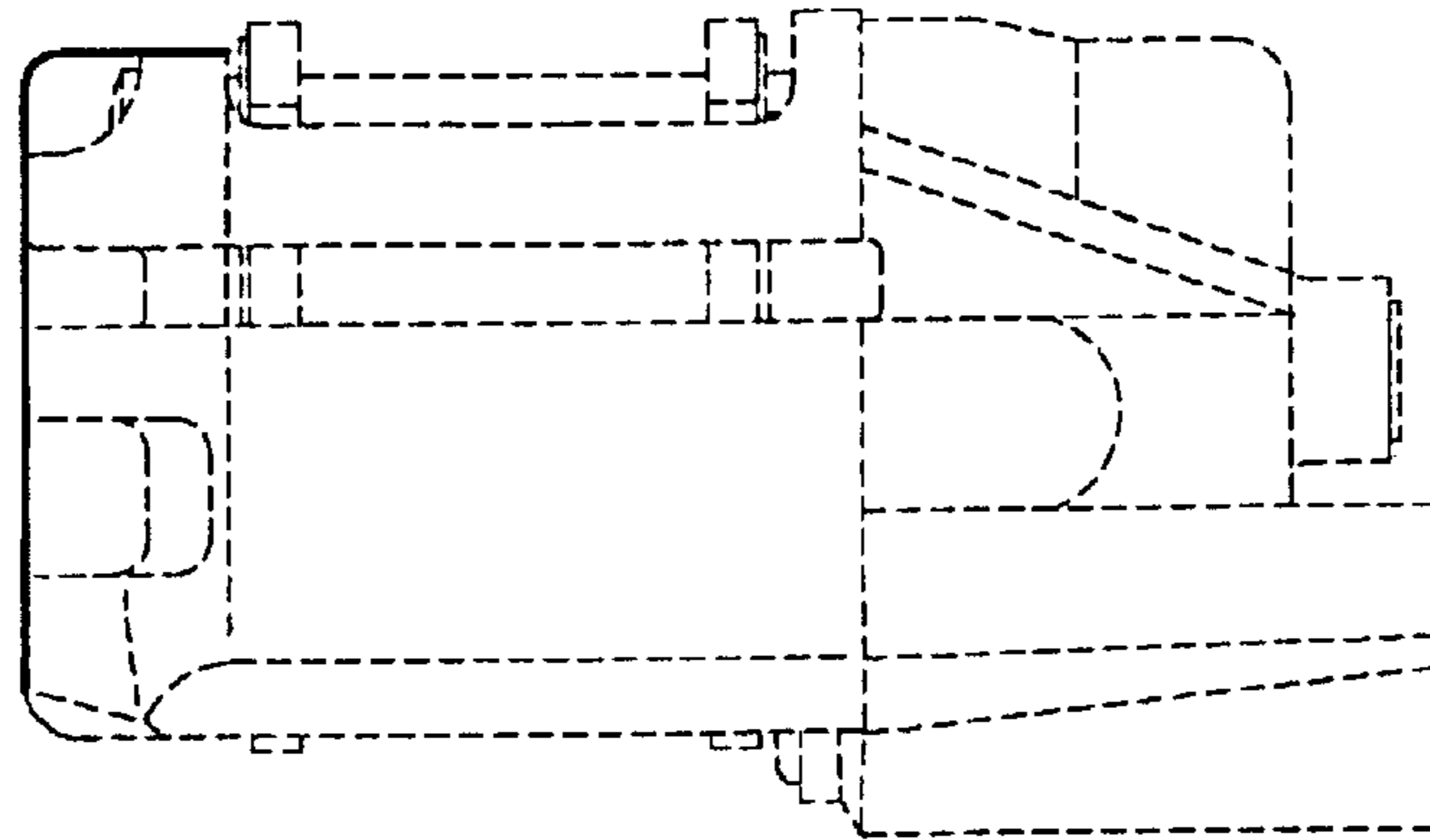

FIG - 3

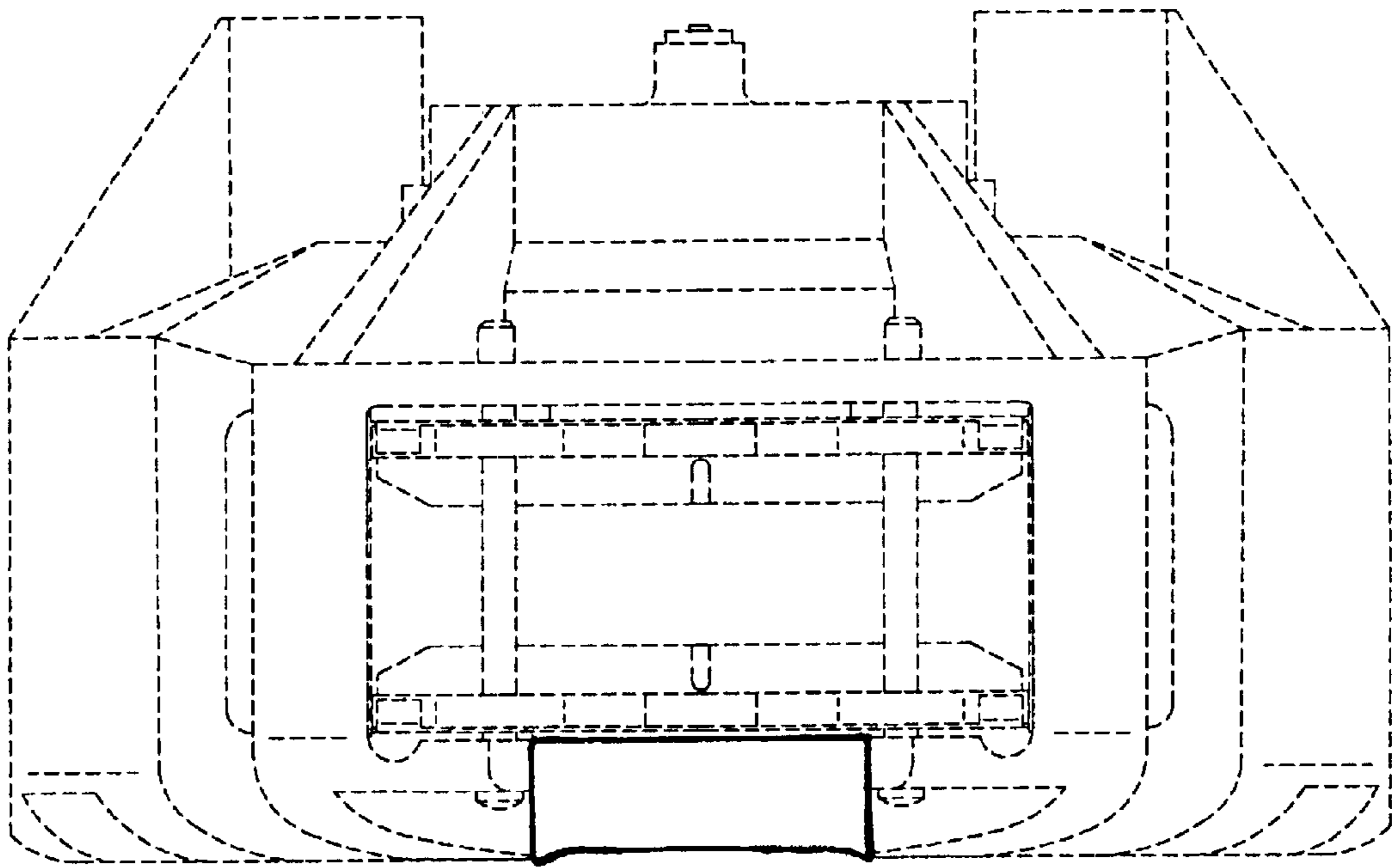

FIG - 4