



US00D488114S

(12) **United States Design Patent**
Kulla

(10) **Patent No.:** **US D488,114 S**

(45) **Date of Patent:** **** Apr. 6, 2004**

(54) **SURFACE CONFIGURATION OF AN EXHAUST PIPE FOR A VEHICLE**

D460,726 S * 7/2002 Campbell et al. D12/194
D473,175 S * 4/2003 Gilli D12/194

(75) Inventor: **Matthias Kulla**, Leonberg (DE)

* cited by examiner

(73) Assignee: **Dr. Ing. h.c.F. Porsche Aktiengesellschaft**, Stuttgart (DE)

Primary Examiner—Stacia Cadmus

(74) *Attorney, Agent, or Firm*—Crowell & Moring LLP

(**) Term: **14 Years**

(57) **CLAIM**

(21) Appl. No.: **29/178,238**

The ornamental design for the surface configuration of an exhaust pipe for a vehicle, as shown and described.

(22) Filed: **Mar. 25, 2003**

DESCRIPTION

(30) **Foreign Application Priority Data**

Sep. 28, 2002 (DE) 4 02 08 087

(51) **LOC (7) Cl.** **12-16**

(52) **U.S. Cl.** **D12/194**

(58) **Field of Search** D12/194, 110,
D12/400; D15/5; 181/239, 227-228, 247;
60/302, 313, 323; 138/37; 29/890.08

FIG. 1 is a front, right perspective view of a surface configuration of an exhaust pipe for a vehicle according to my novel design;

FIG. 2 is a front view of the surface configuration of an exhaust pipe for a vehicle according to my novel design;

FIG. 3 is a bottom view of the surface configuration of an exhaust pipe for a vehicle according to my novel design;

FIG. 4 is a top view of the surface configuration of an exhaust pipe for a vehicle according to my novel design;

FIG. 5 is a right side view of the surface configuration of an exhaust pipe for a vehicle according to my novel design; and,

FIG. 6 is a left side view of the surface configuration of an exhaust pipe for a vehicle according to my novel design.

Also enclosed is a set of photographs of an embodiment of my invention. The dash lines included depict environment and are not part of the claimed design.

(56) **References Cited**

U.S. PATENT DOCUMENTS

D159,865 S * 8/1950 Russell D12/194
D165,985 S * 2/1952 Koonter D12/194
2,909,235 A * 10/1959 Beranek 181/227
4,537,278 A * 8/1985 Okada et al. 181/227
D289,766 S * 5/1987 Evans D12/194 X
D418,469 S * 1/2000 Whisenhunt D12/194
D423,436 S * 4/2000 Larson D12/194

1 Claim, 3 Drawing Sheets

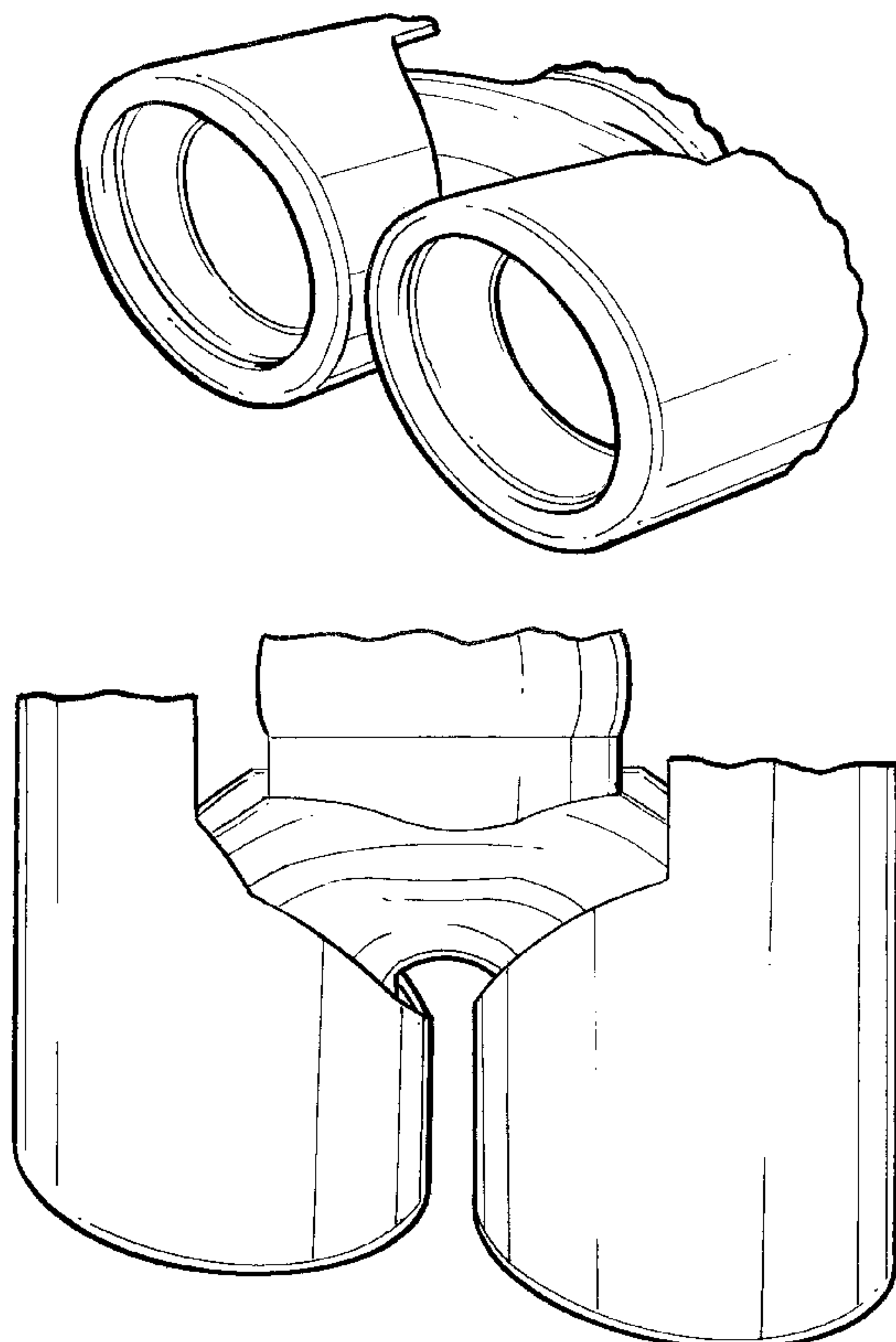

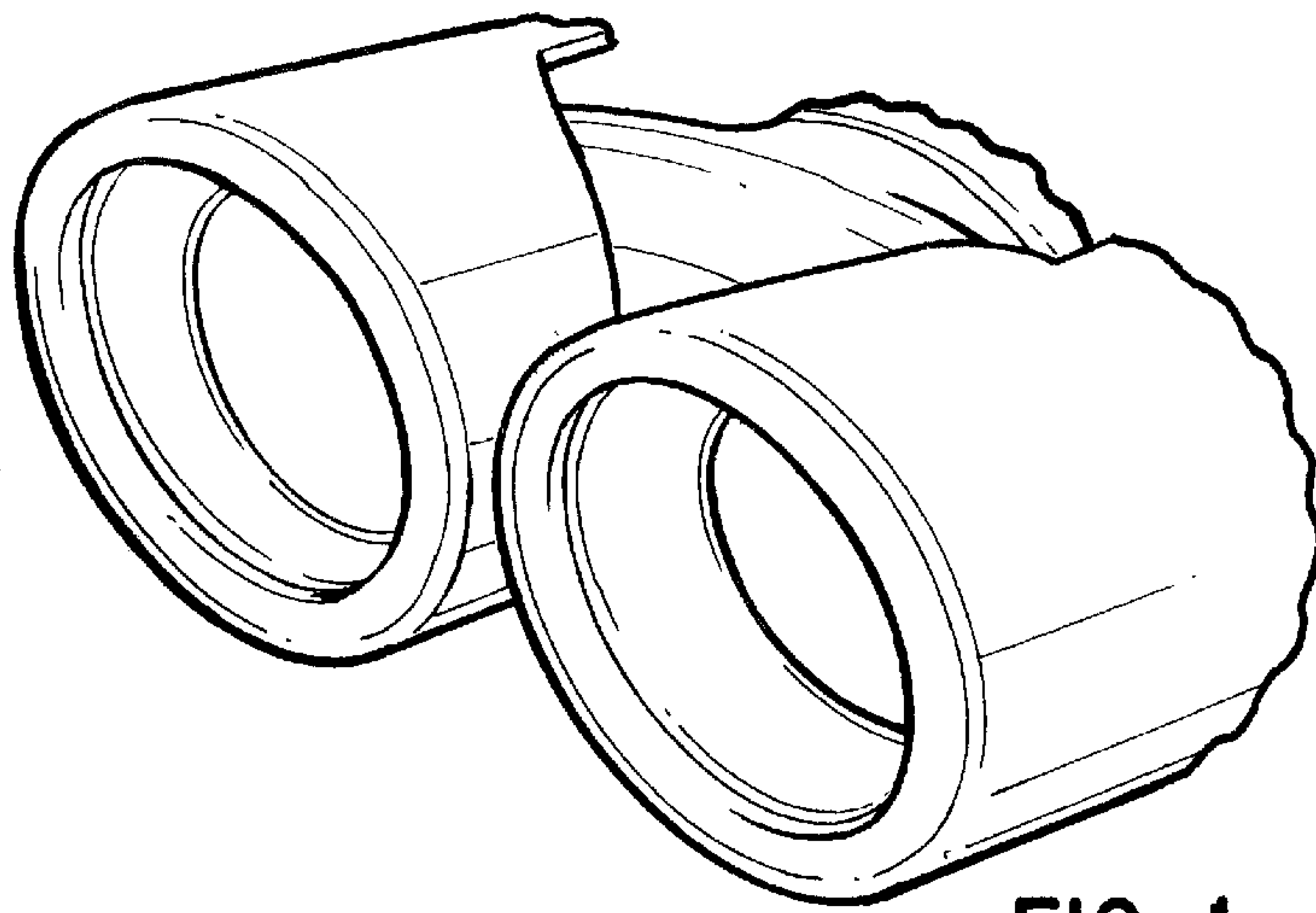

FIG. 1

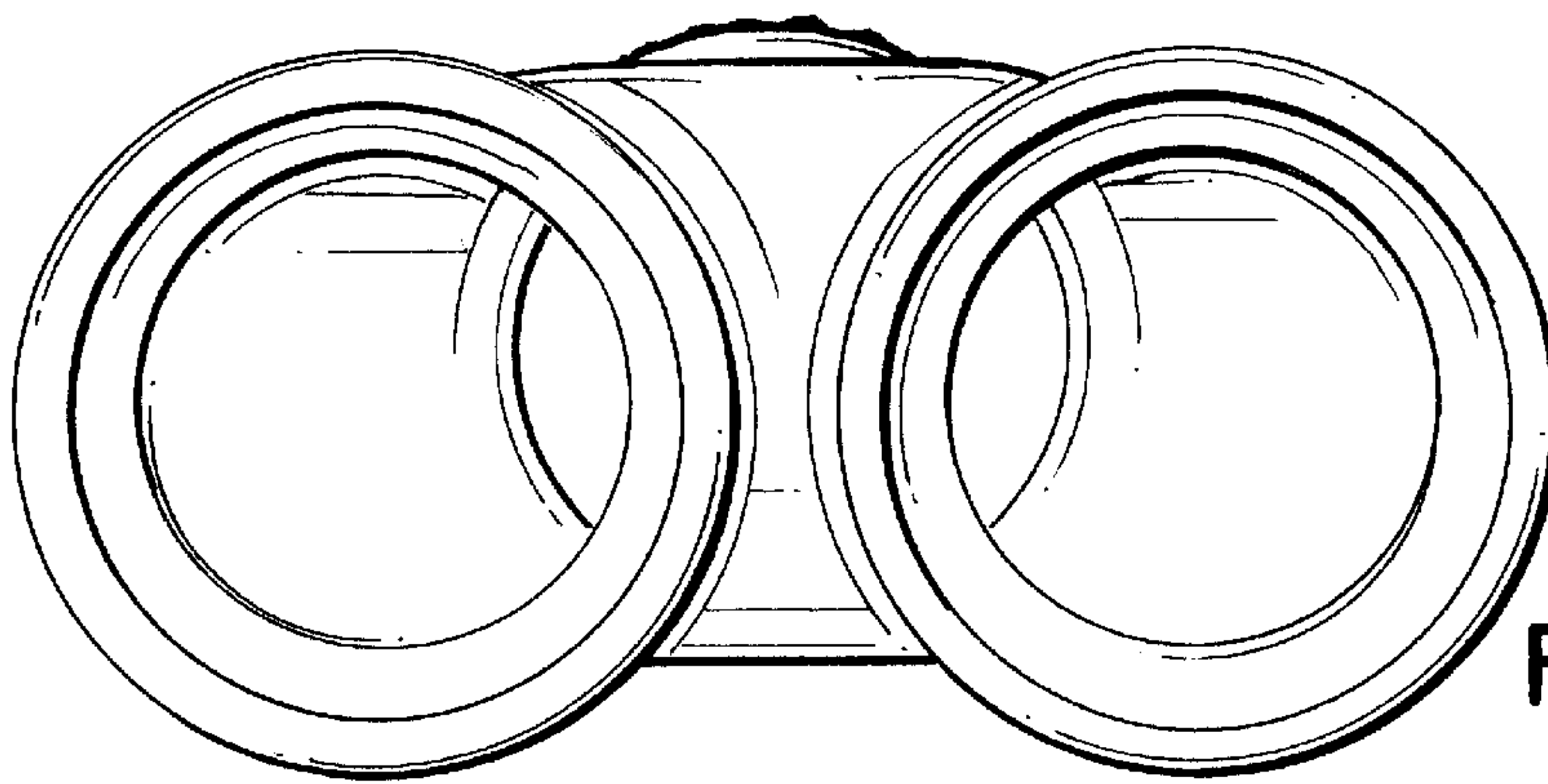

FIG. 2

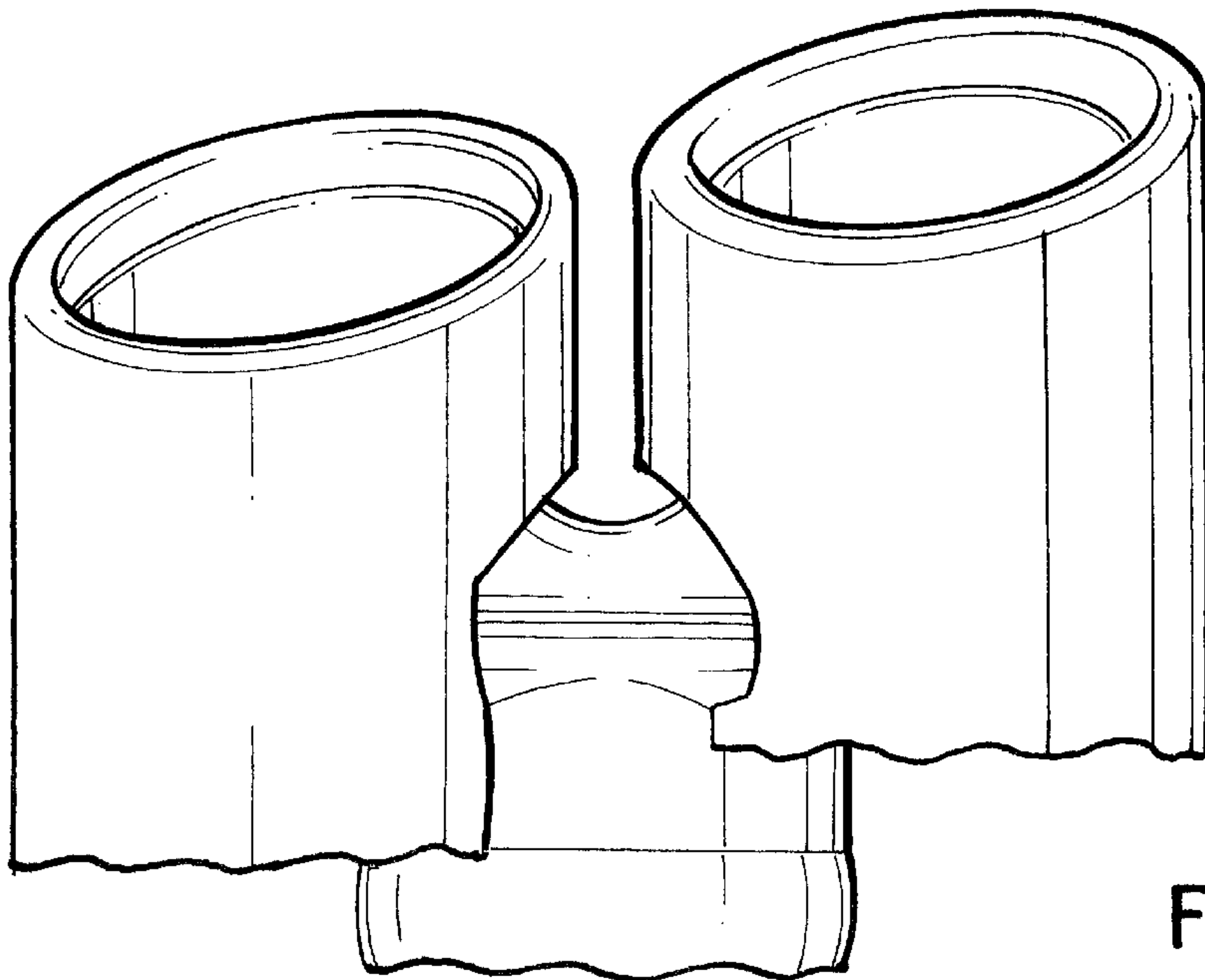

FIG. 3

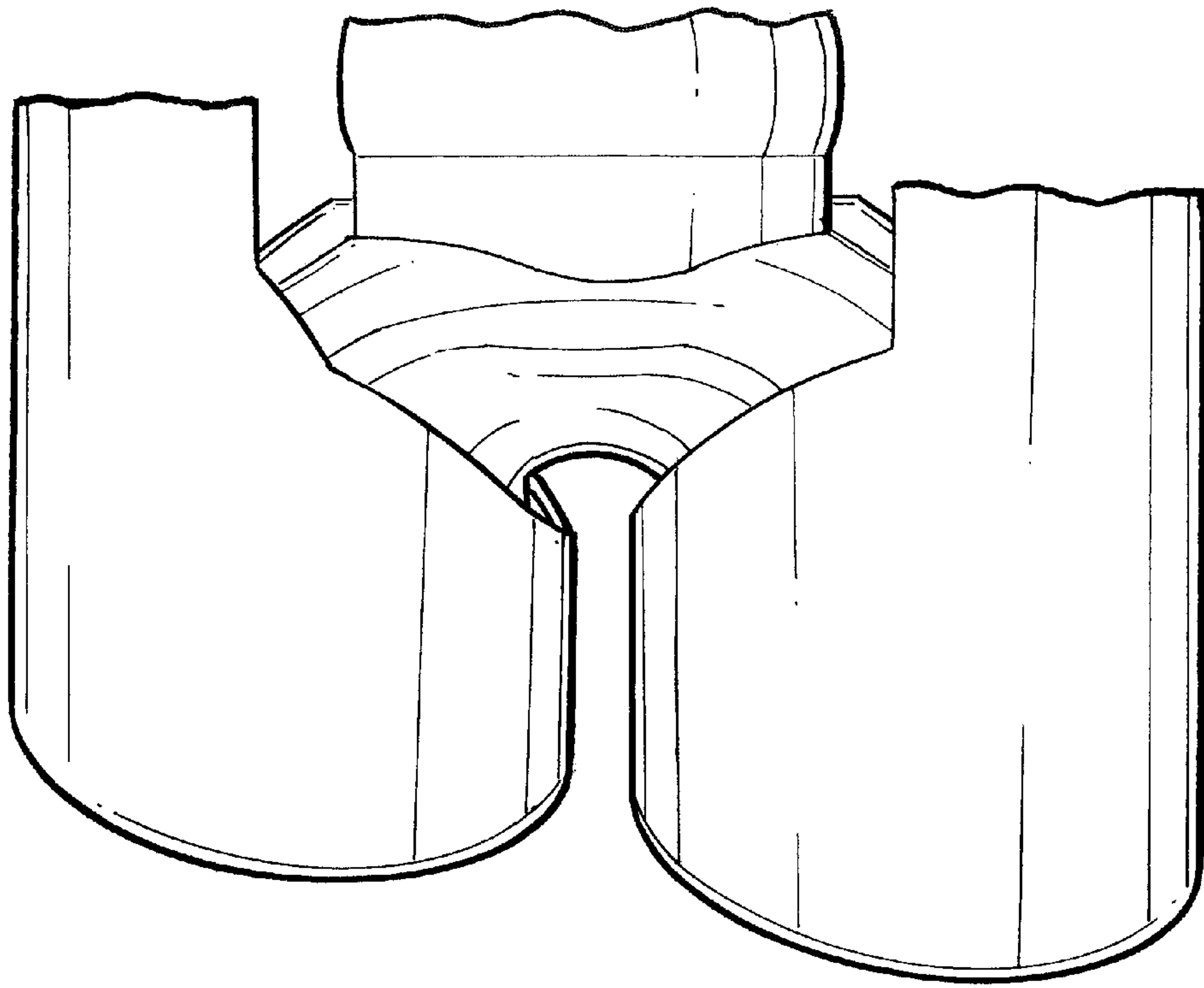

FIG. 4

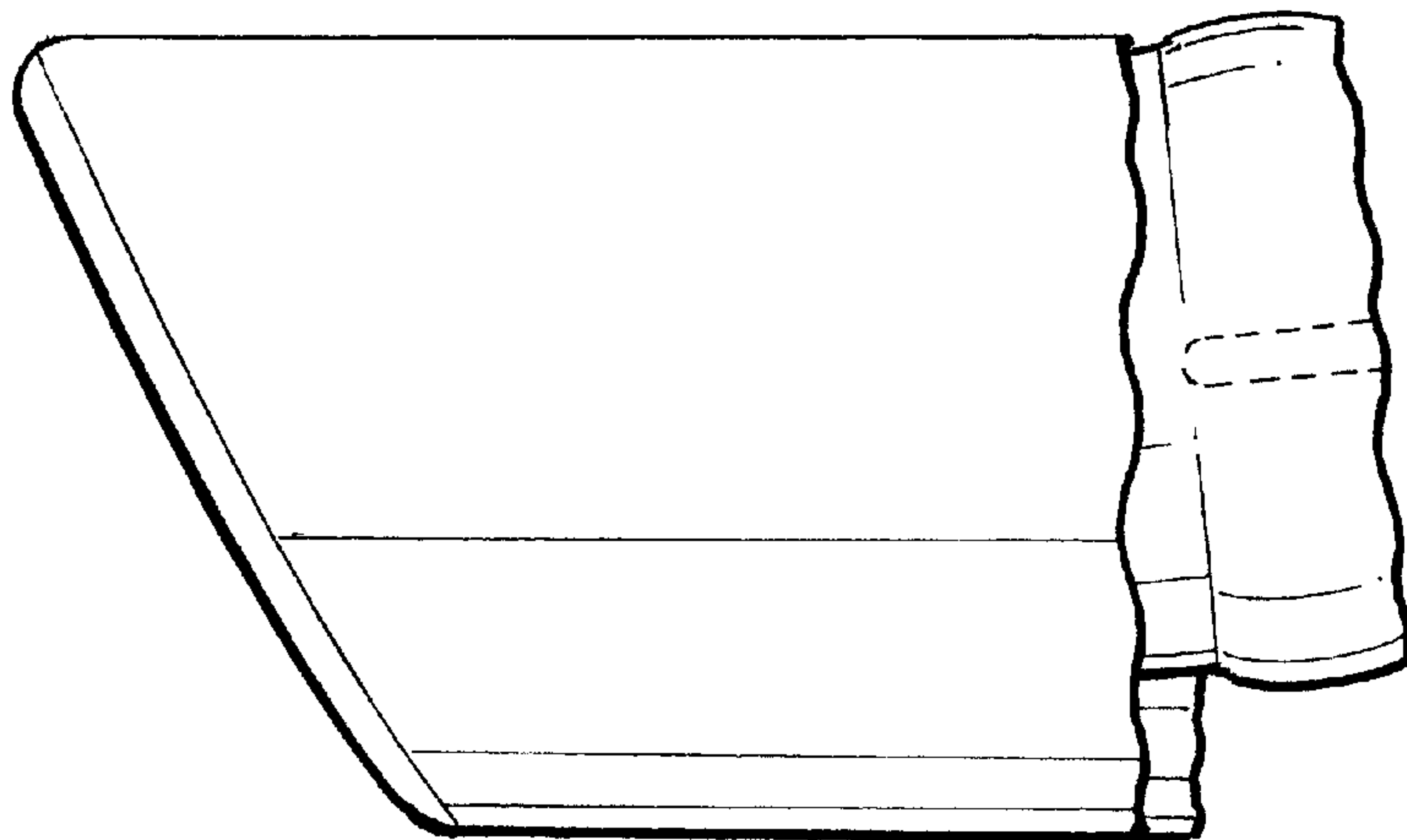

FIG. 5

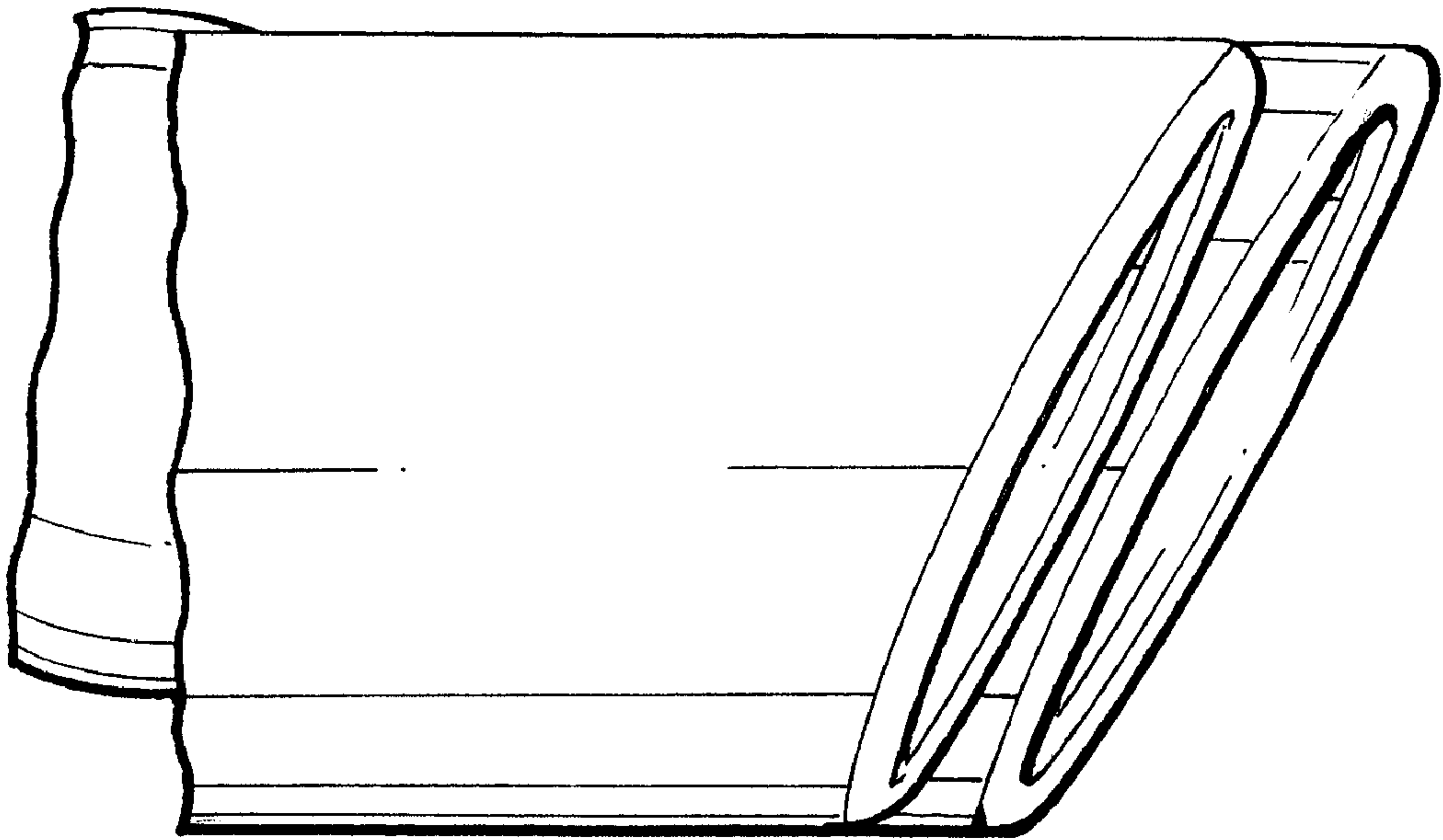

FIG. 6