



US00D488113S

(12) **United States Design Patent**
Nelson

(10) **Patent No.:** **US D488,113 S**

(45) **Date of Patent:** **** Apr. 6, 2004**

(54) **VEHICLE AIR DEFLECTOR**

(76) Inventor: **Dennis I. Nelson**, P.O. Box 426, Darby, MT (US) 59829

(**) Term: **14 Years**

(21) Appl. No.: **29/163,859**

(22) Filed: **Jul. 12, 2002**

(51) **LOC (7) Cl.** **12-16**

(52) **U.S. Cl.** **D12/181**

(58) **Field of Search** D12/181, 191,
D12/196; 160/133, DIG. 1; 280/848; 296/180.1-180.5,
82, 208, 91

(56) **References Cited**

U.S. PATENT DOCUMENTS

D206,972 S	2/1967	Borick	
D238,666 S	2/1976	Herrod	
3,999,797 A	12/1976	Kirsch et al.	
4,320,920 A	3/1982	Goudey	
4,603,810 A	8/1986	Schleimer et al.	
D290,454 S	* 6/1987	Menking et al.	D12/181
4,674,788 A	6/1987	Ohmura et al.	
4,881,772 A	11/1989	Feinberg	
D319,613 S	* 9/1991	Mikawa	D12/181
5,199,762 A	4/1993	Scheele et al.	
D401,199 S	* 11/1998	Kovach et al.	D12/181
D422,544 S	* 4/2000	Carlson et al.	D12/181
D427,126 S	* 6/2000	Won et al.	D12/181
D436,905 S	* 1/2001	Bhambra	D12/181
D465,180 S	* 11/2002	Yokomaku	D12/181
D473,831 S	* 4/2003	Saleen	D12/181

FOREIGN PATENT DOCUMENTS

FR	7490596	1/1933
FR	2 594 497 A1	2/1986

GB	1066371	4/1967
GB	1215688	12/1970
JP	67-18785	1/1989

* cited by examiner

Primary Examiner—Stacia Cadmus

(74) *Attorney, Agent, or Firm*—Wells St. John P.S.

(57) **CLAIM**

I claim the ornamental design for a vehicle air deflector, as shown and described.

DESCRIPTION

FIG. 1 is a rear left side perspective view of my new design for a vehicle air deflector with broken lines illustrating environment that does not constitute part of the design; FIG. 2 is a front right side perspective view of my new design for a vehicle air deflector with broken lines illustrating environment that does not constitute part of the design; FIG. 3 is a left side elevational view thereof, of which the right side elevational view is a mirror image thereof; FIG. 4 is a front view thereof with broken lines illustrating environment that does not constitute part of the design; FIG. 5 is a rear view thereof, with broken lines illustrating environment that does not constitute part of the design; FIG. 6 is a top elevational view thereof; FIG. 7 is a vertical cross sectional view taken along line 7—7 in FIG. 6, in which the broken lines are illustrating environment that does not constitute part of the design, it being understood that a cross-section view taken in the opposite direction is a mirror image thereof; and, FIG. 8 is a bottom elevational view thereof. FIGS. 2, 4, 5, 6 and 8 have been shown with a central section broken away for convenience of illustration to shown the design in larger scale.

1 Claim, 8 Drawing Sheets

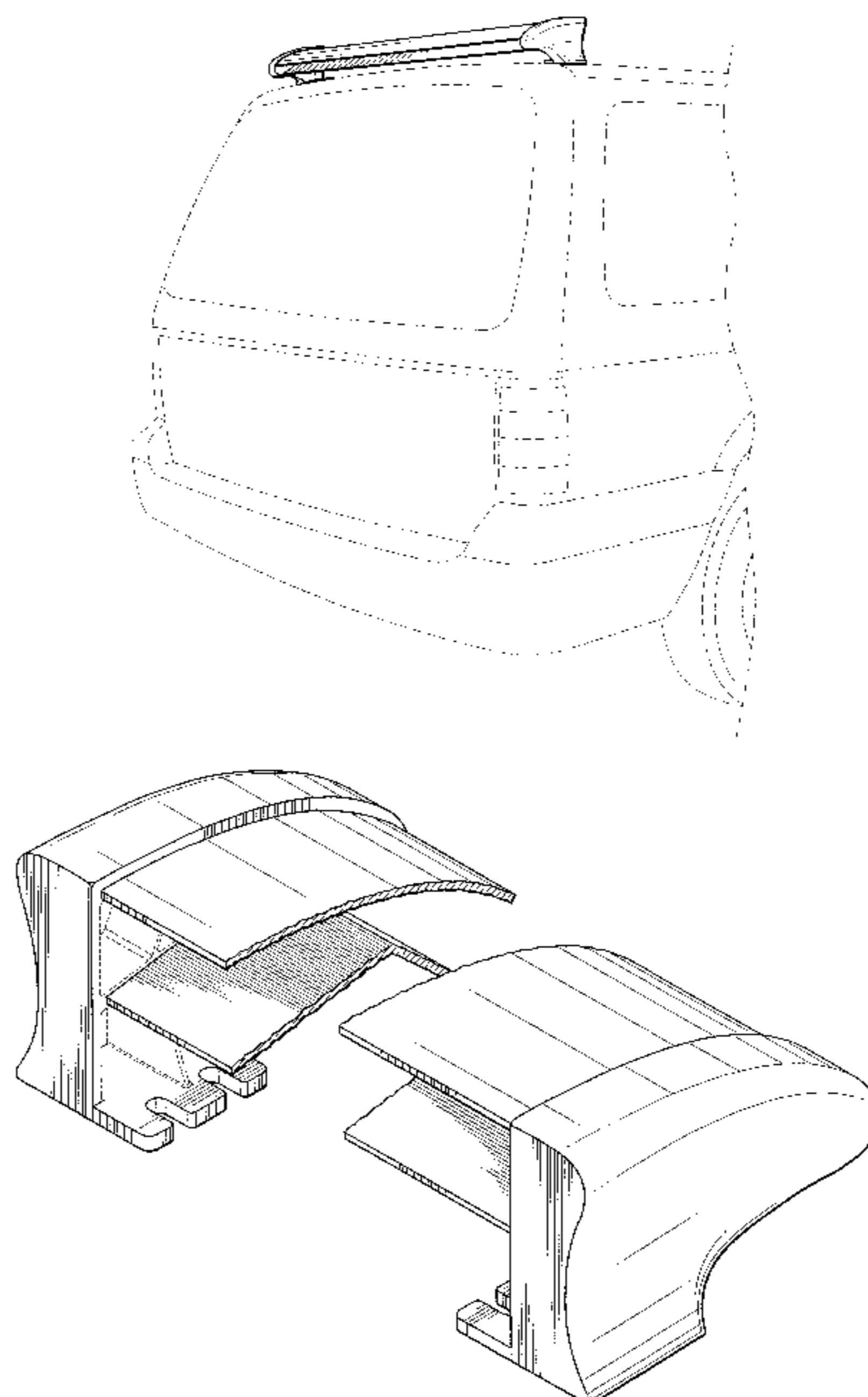

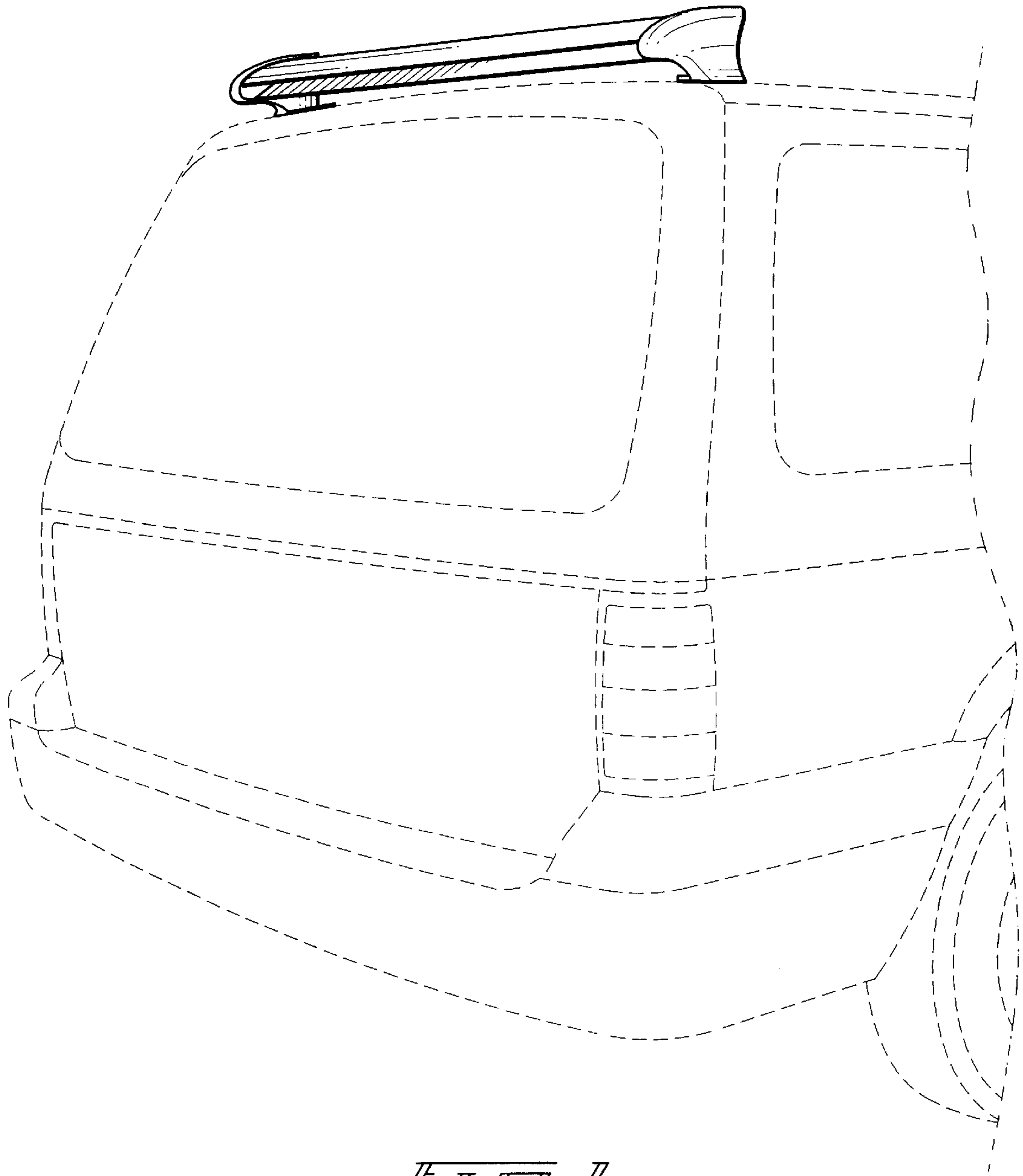

FIG. 1

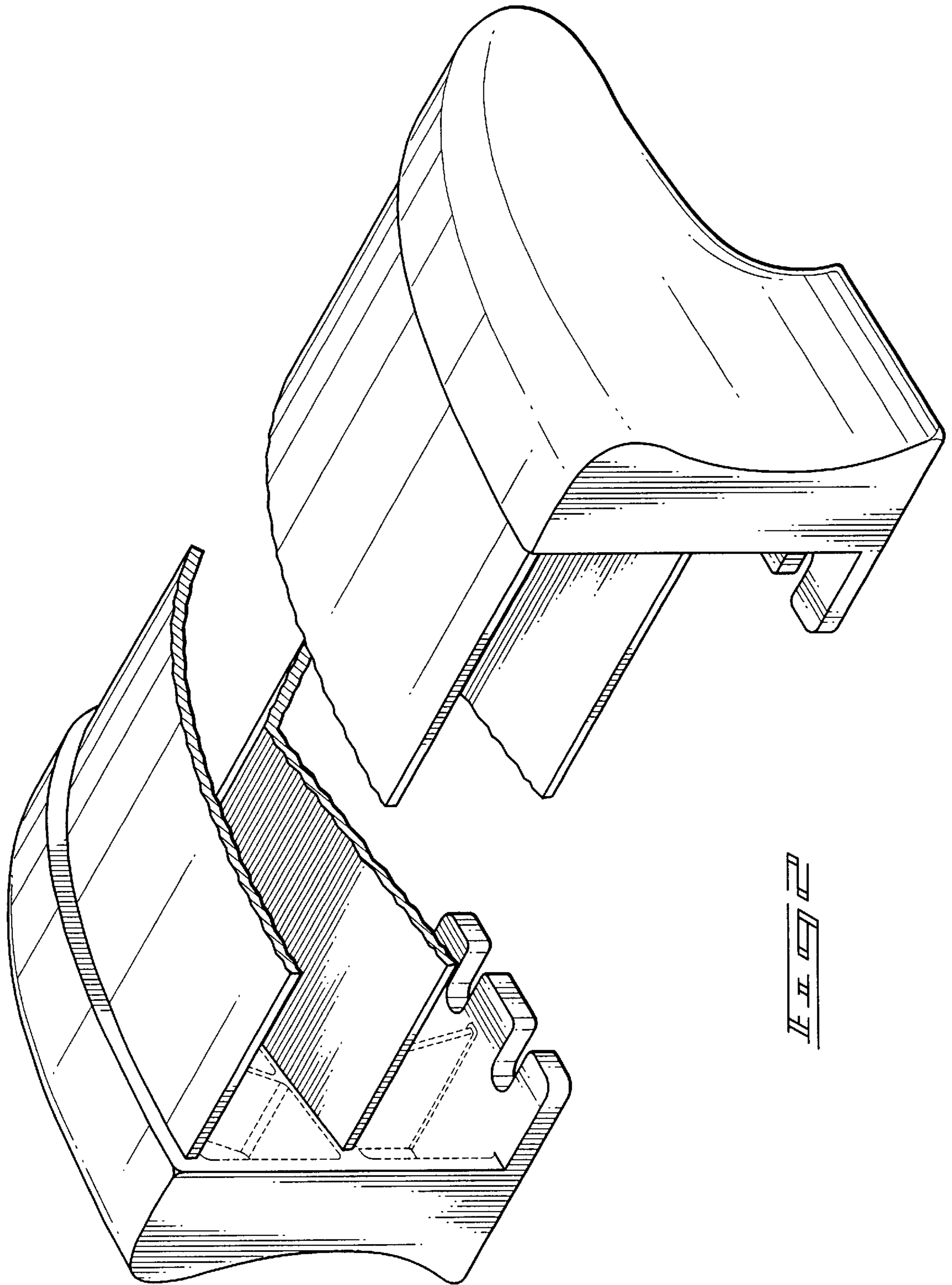

FIG. 2

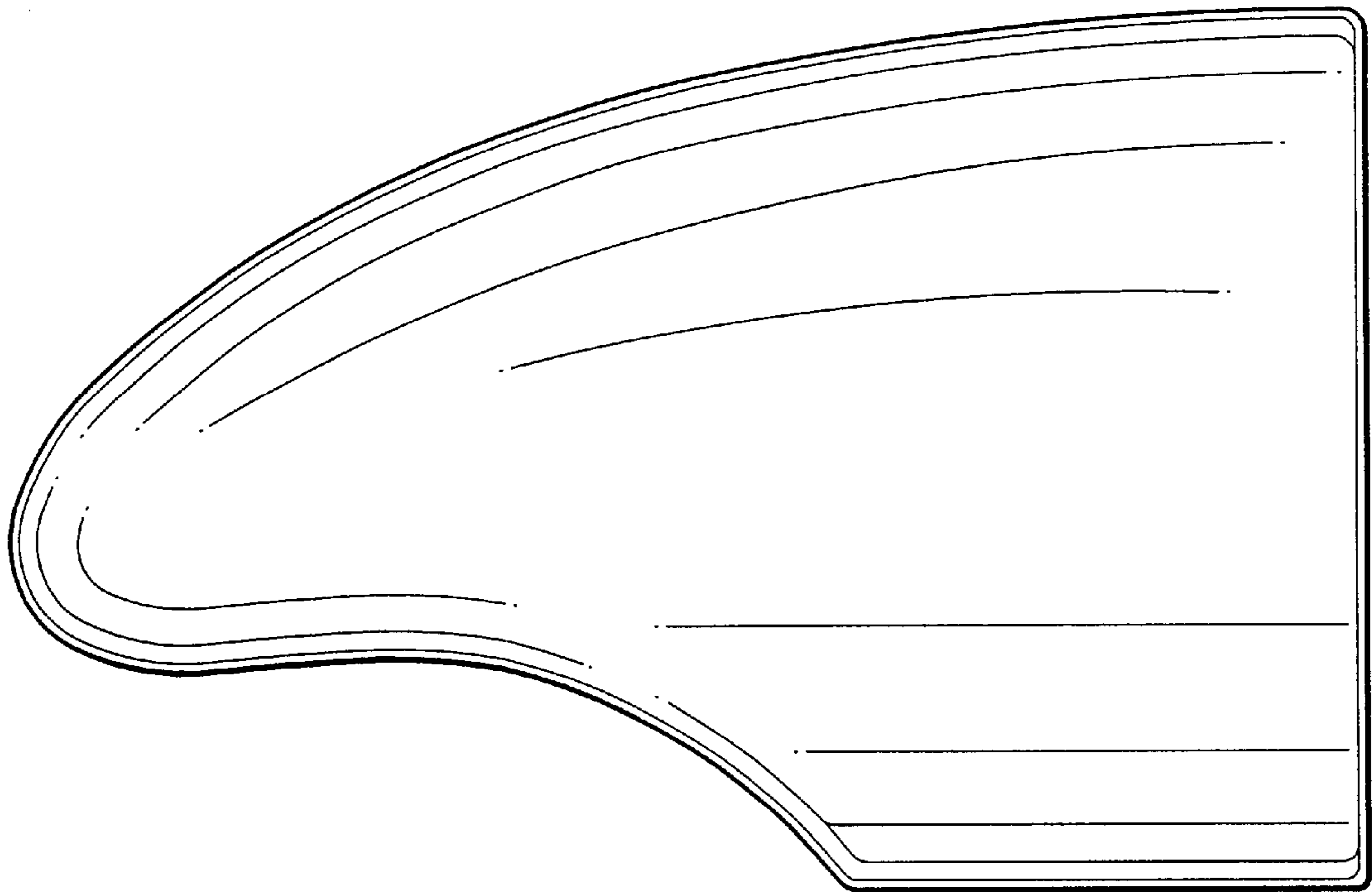

FIG. 3

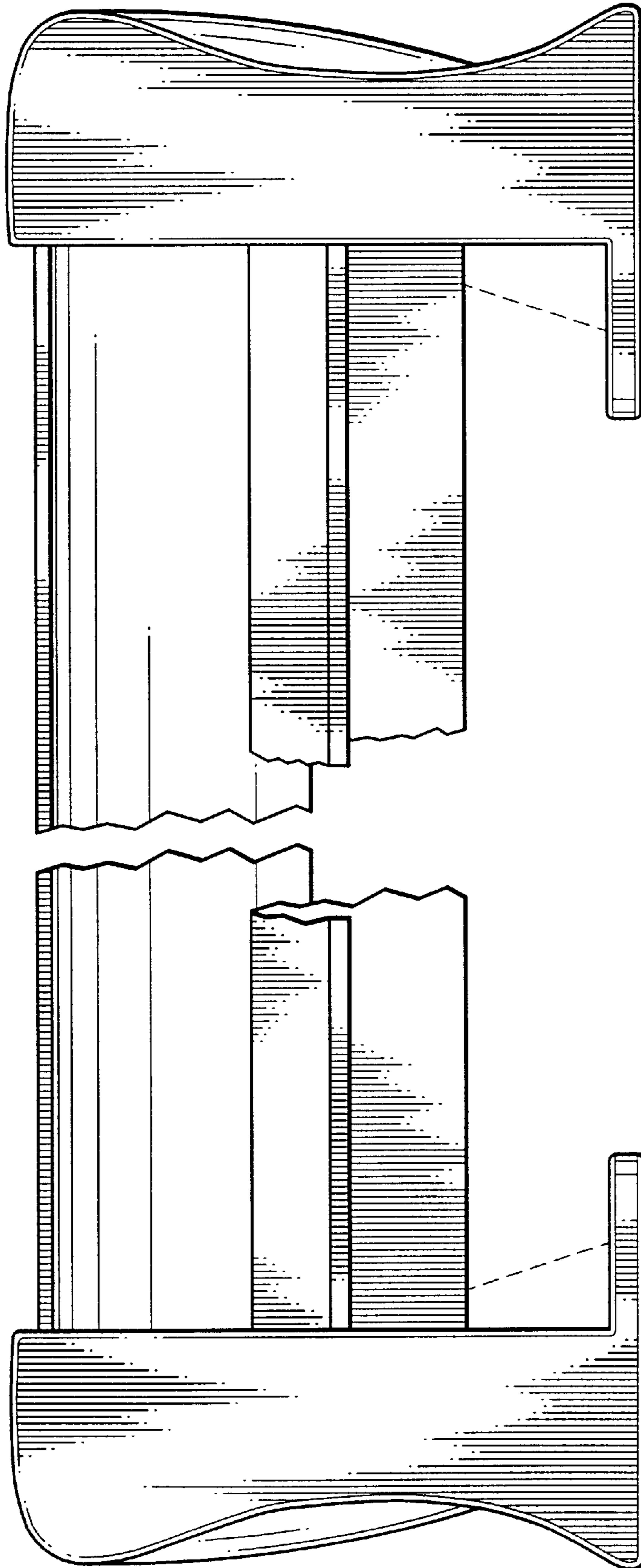

FIG. 4

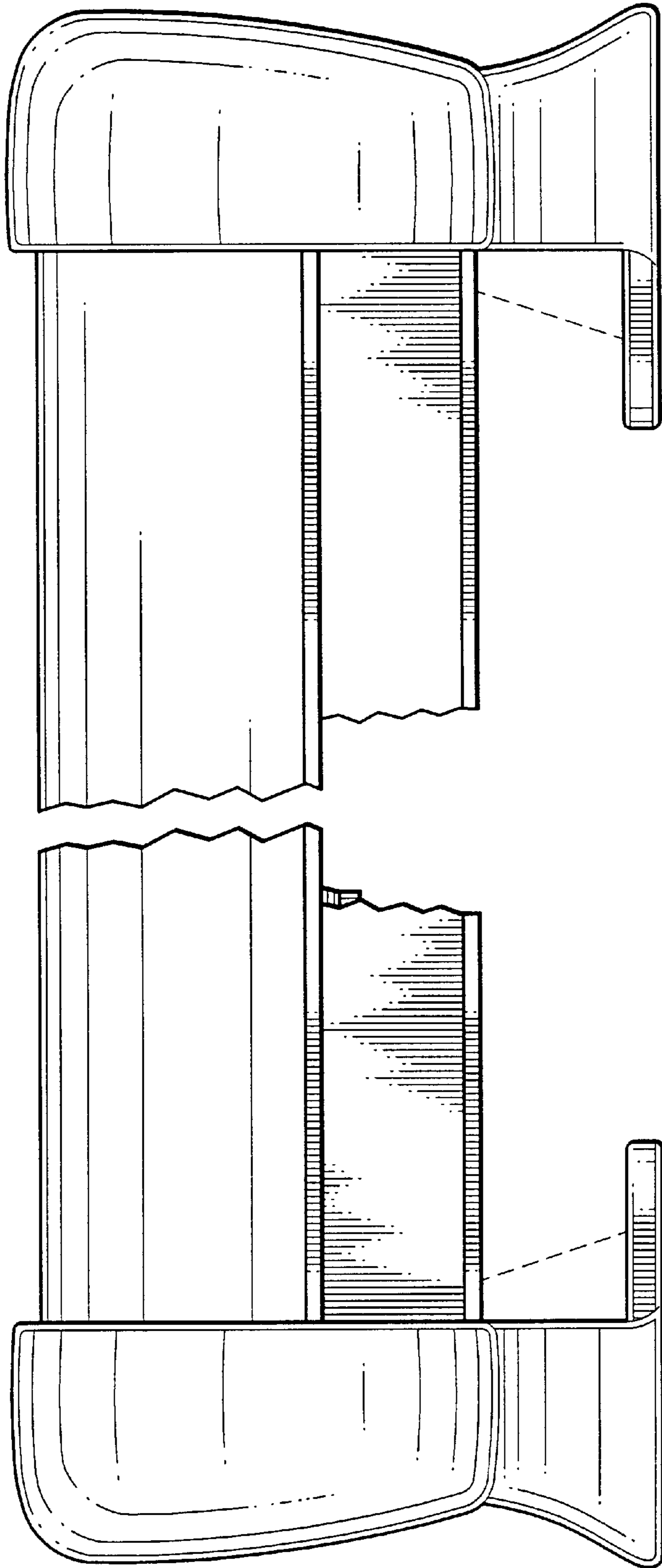
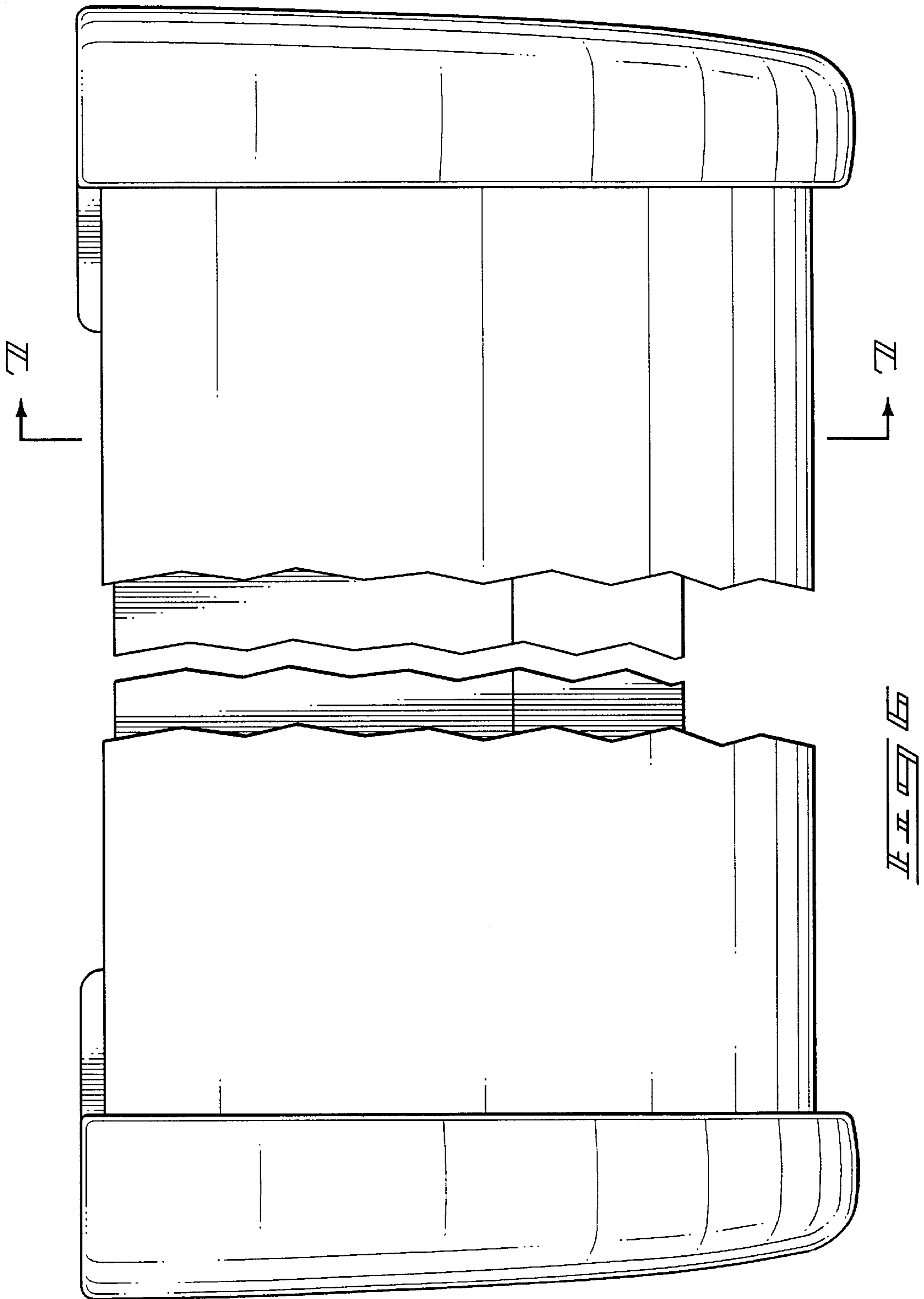

FIG. 5



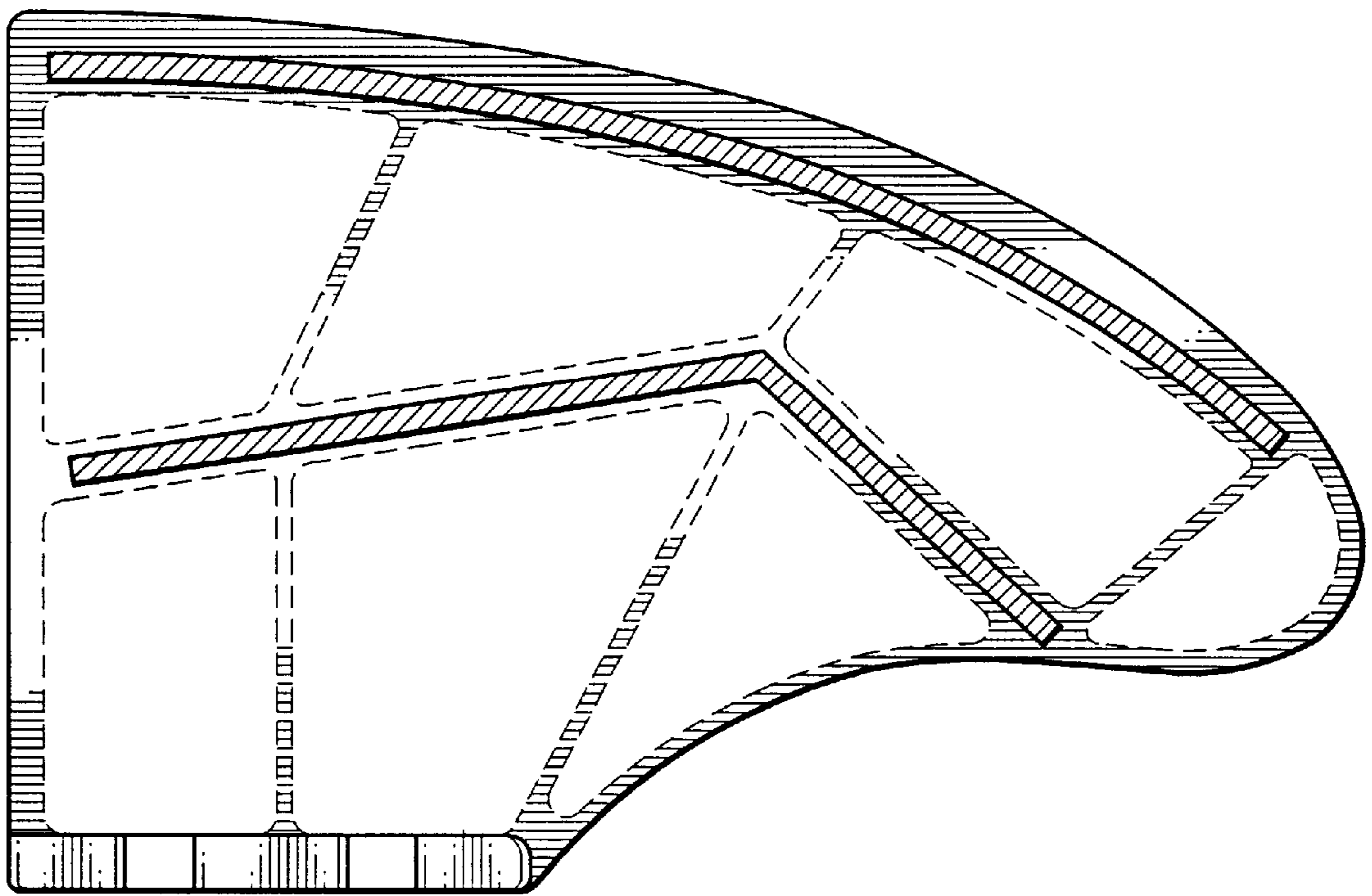

FIG. 7

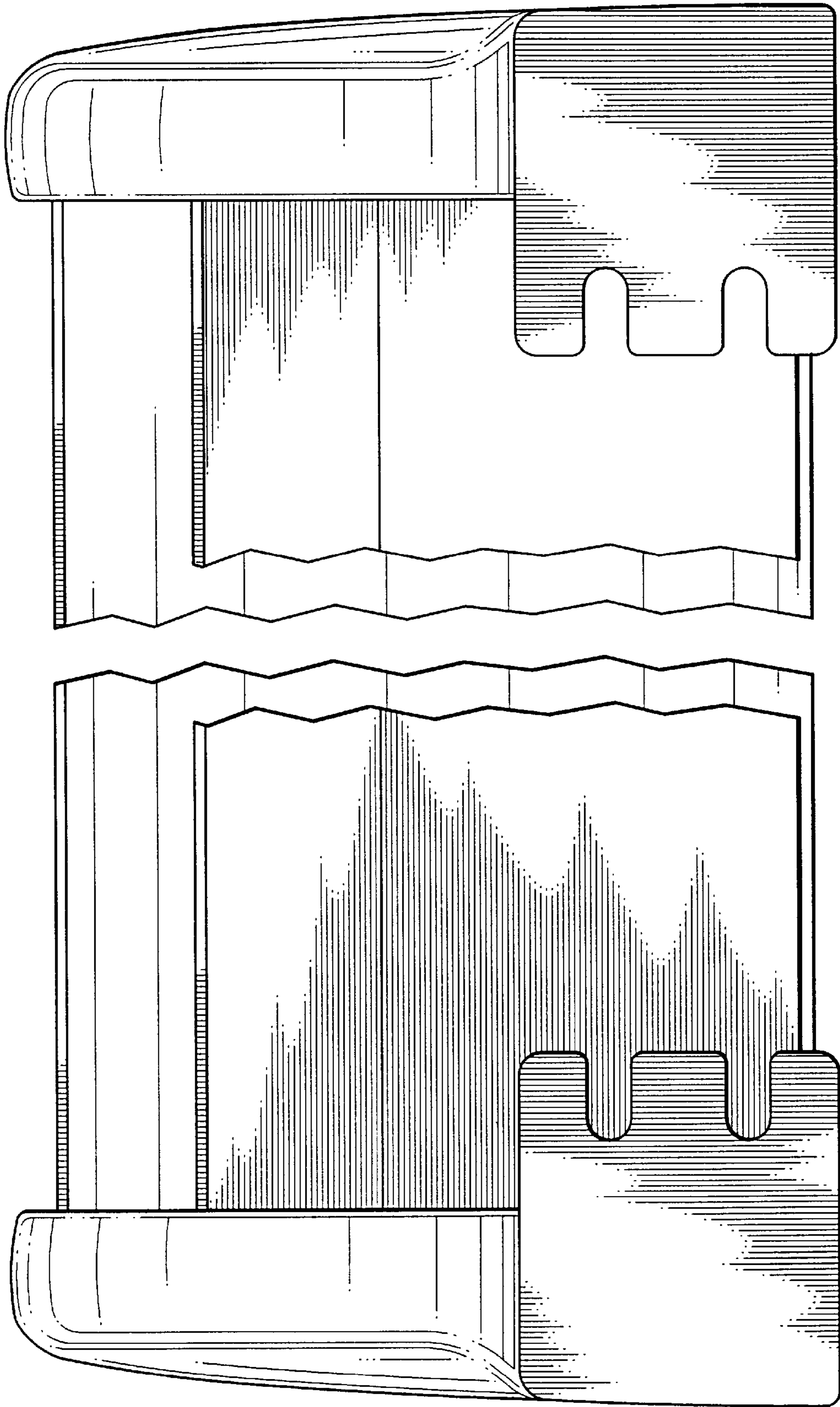

FIG. 8

UNITED STATES PATENT AND TRADEMARK OFFICE
CERTIFICATE OF CORRECTION

PATENT NO. : Des. 488,113 S
DATED : April 6, 2004
INVENTOR(S) : Dennis I. Nelson

Page 1 of 1

It is certified that error appears in the above-identified patent and that said Letters Patent is hereby corrected as shown below:

Title page,

Item [56], **References Cited**, U.S. PATENT DOCUMENTS, replace "D206,972" with -- D206,872 --

FOREIGN PATENT DOCUMENTS, replace "7490596" with -- 749,596 --

Signed and Sealed this

Twenty-first Day of December, 2004

A handwritten signature in black ink that reads "Jon W. Dudas". The signature is written in a cursive style with a large, stylized initial "J".

JON W. DUDAS

Director of the United States Patent and Trademark Office