



US00D487237S

(12) **United States Design Patent**
Newport

(10) **Patent No.:** **US D487,237 S**

(45) **Date of Patent:** **** Mar. 2, 2004**

(54) **TRAILER HITCH BAR**

(75) **Inventor:** **Colin Newport, Ayr (CA)**

(73) **Assignee:** **Copperweld Canada Inc. (CA)**

(**) **Term:** **14 Years**

(21) **Appl. No.:** **29/166,812**

(22) **Filed:** **Sep. 3, 2002**

(30) **Foreign Application Priority Data**

Mar. 1, 2002 (CA) 98827

(51) **LOC (7) Cl.** **12-16**

(52) **U.S. Cl.** **D12/162**

(58) **Field of Search** D12/162, 400;
D8/381; 280/490.1, 490.2, 457, 495, 475,
491.5, 479.2, 507, 481.5, 500-504, 402;
248/224.7; 293/117

(56) **References Cited**

U.S. PATENT DOCUMENTS

D208,535 S	*	9/1967	Moll	D12/162
D214,787 S	*	7/1969	Whisnand	D12/162
D265,645 S	*	8/1982	Hampton	D12/162 X
D268,574 S	*	4/1983	Hampton	D12/162 X
D338,119 S	*	8/1993	Merrick	D12/162 X
D341,117 S	*	11/1993	Sundstedt	D12/162
D358,570 S	*	5/1995	Doherty et al.	D12/162
D373,557 S	*	9/1996	Shaw et al.	D12/162
D375,923 S	*	11/1996	McCoy et al.	D12/162
D379,343 S	*	5/1997	Shaw et al.	D12/162
5,853,187 A	*	12/1998	Maier	280/495
D420,631 S	*	2/2000	Shaw et al.	D12/162
D424,990 S	*	5/2000	McCoy et al.	D12/162
D434,708 S	*	12/2000	McCoy et al.	D12/162
6,234,512 B1	*	5/2001	Bettenhausen	280/491.1
D445,382 S	*	7/2001	Lindenman et al.	D12/162

D445,738 S	*	7/2001	Lindenman et al.	D12/162
6,464,240 B1	*	10/2002	Seksaria et al.	280/495
D470,085 S	*	2/2003	Newport	D12/162
D470,444 S	*	2/2003	Newport	D12/162
6,540,277 B2	*	4/2003	McCoy et al.	293/117
D474,134 S	*	5/2003	Belinky et al.	D12/162

* cited by examiner

Primary Examiner—Stacia Cadmus

(74) *Attorney, Agent, or Firm*—Piper Rudnick LLP

(57) **CLAIM**

The ornamental design for a trailer hitch bar, as shown and described.

DESCRIPTION

FIG. 1 is a perspective view of the trailer hitch bar showing my new design;
 FIG. 2 is a top view thereof;
 FIG. 3 is a rear view thereof;
 FIG. 4 is a side view thereof;
 FIG. 5 is a perspective view of a second embodiment of the trailer hitch bar;
 FIG. 6 is a top view of FIG. 5
 FIG. 7 is a rear view of FIG. 5
 FIG. 8 is a side view of FIG. 5;
 FIG. 9 is a perspective view of a third embodiment of the trailer hitch bar;
 FIG. 10 is a top view of FIG. 9;
 FIG. 11 is a rear view of FIG. 9;
 FIG. 12 is a side view of FIG. 9
 FIG. 13 is a perspective view of a fourth embodiment of the trailer hitch bar;
 FIG. 14 is a top view of FIG. 13
 FIG. 15 is a rear view of FIG. 13; and,
 FIG. 16 is a side view of FIG. 13.

1 Claim, 4 Drawing Sheets

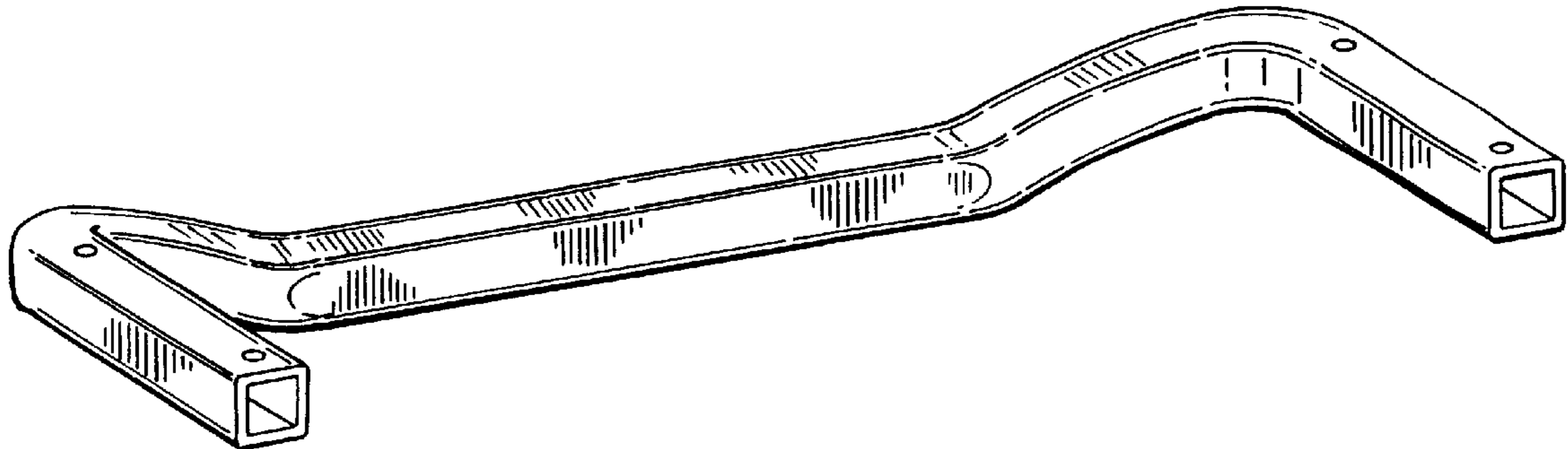

FIG. 1.

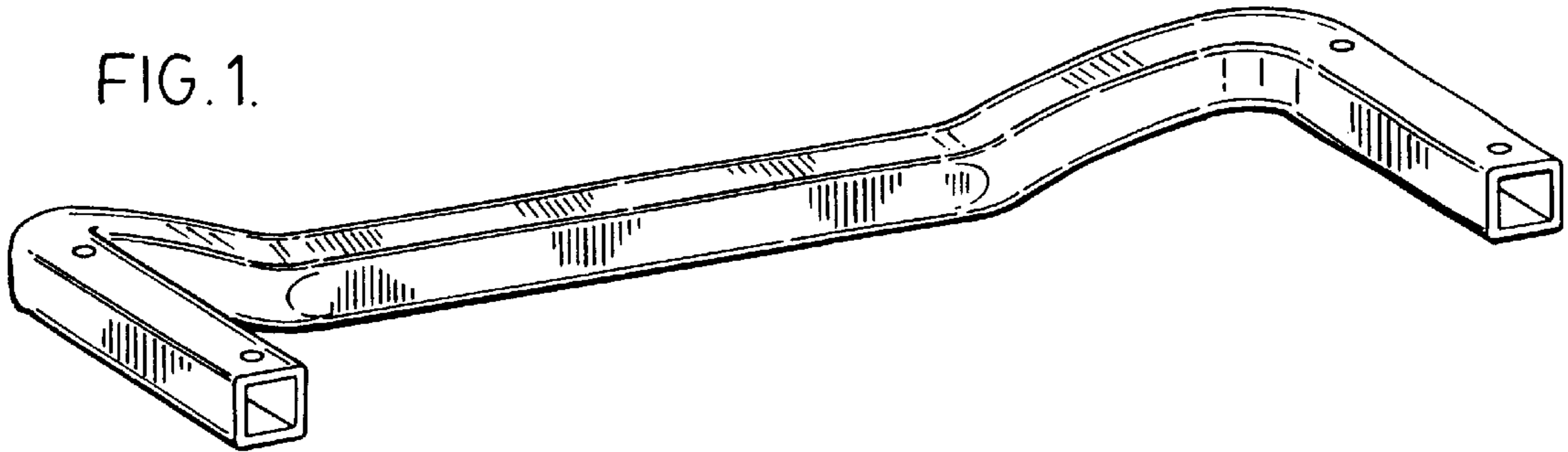

FIG. 2.

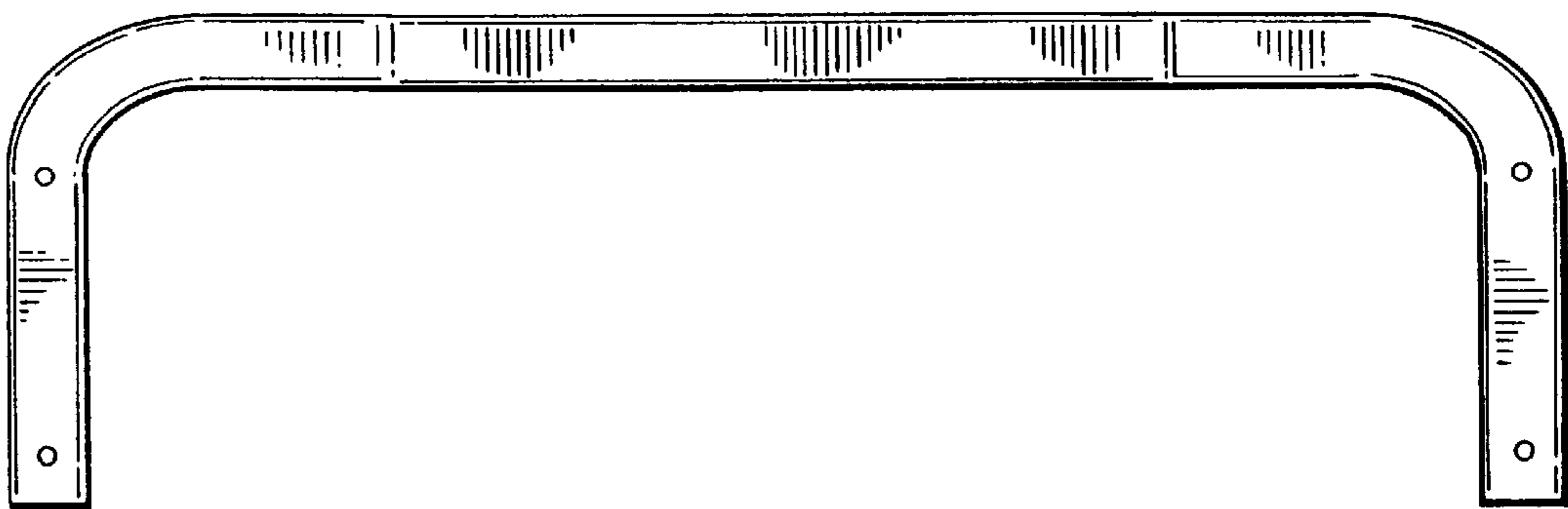

FIG. 3.



FIG. 4.

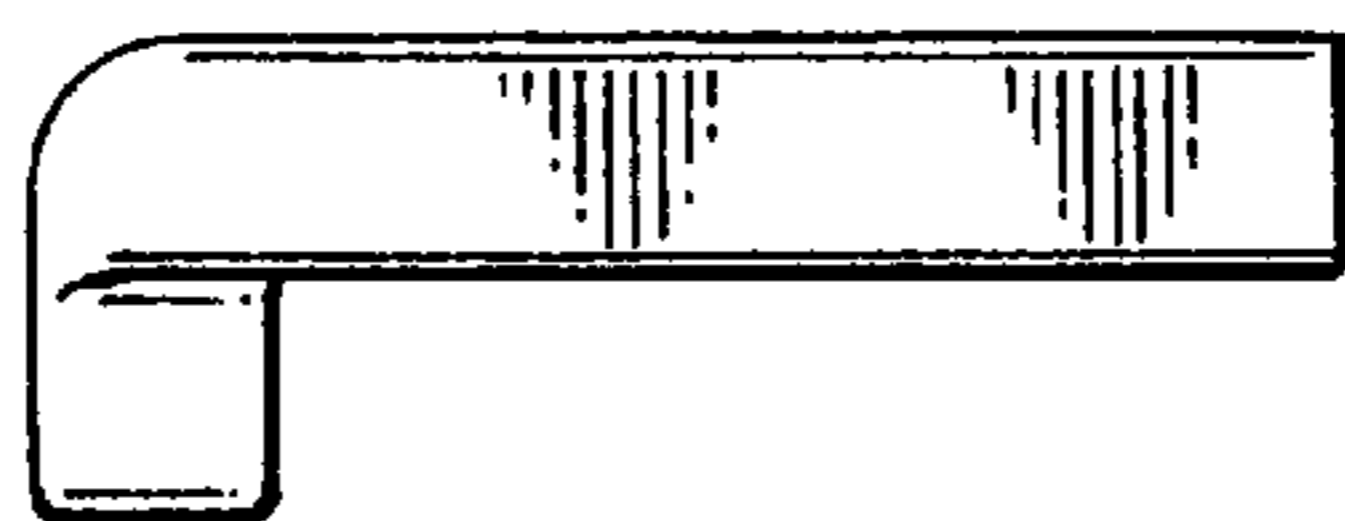

FIG. 5.

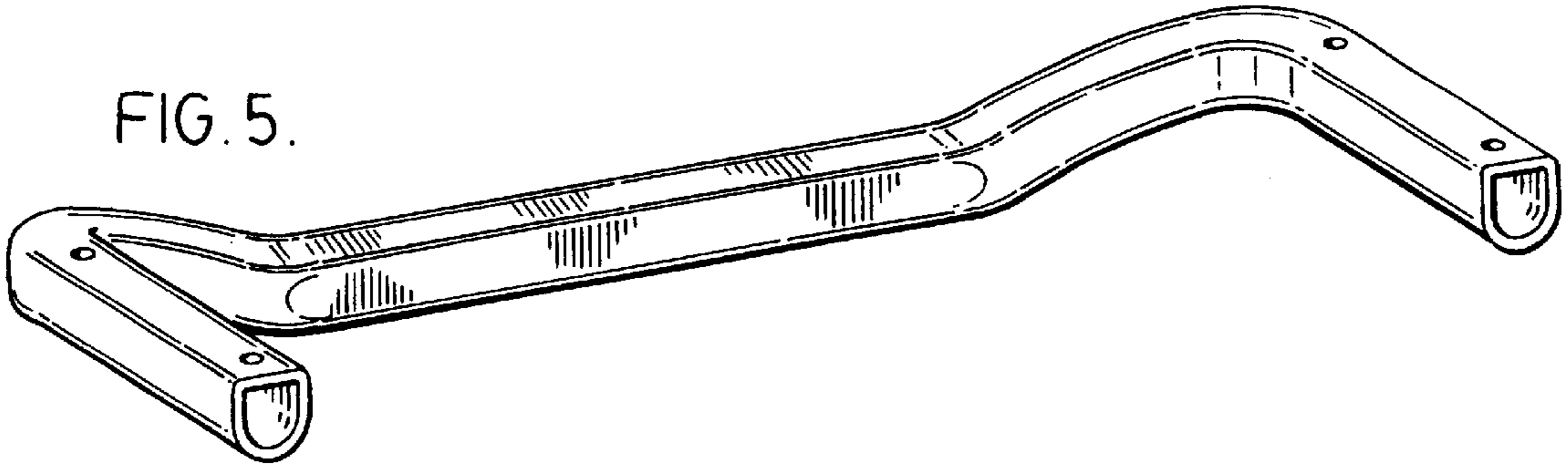

FIG. 6.

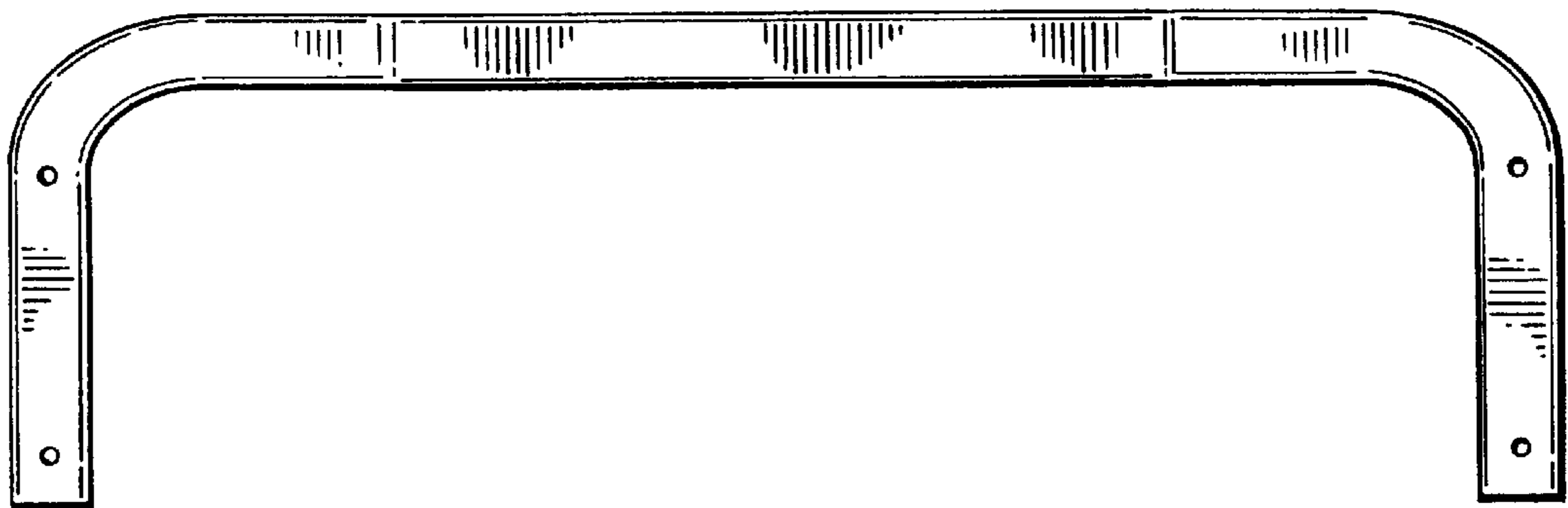

FIG. 7.



FIG. 8.

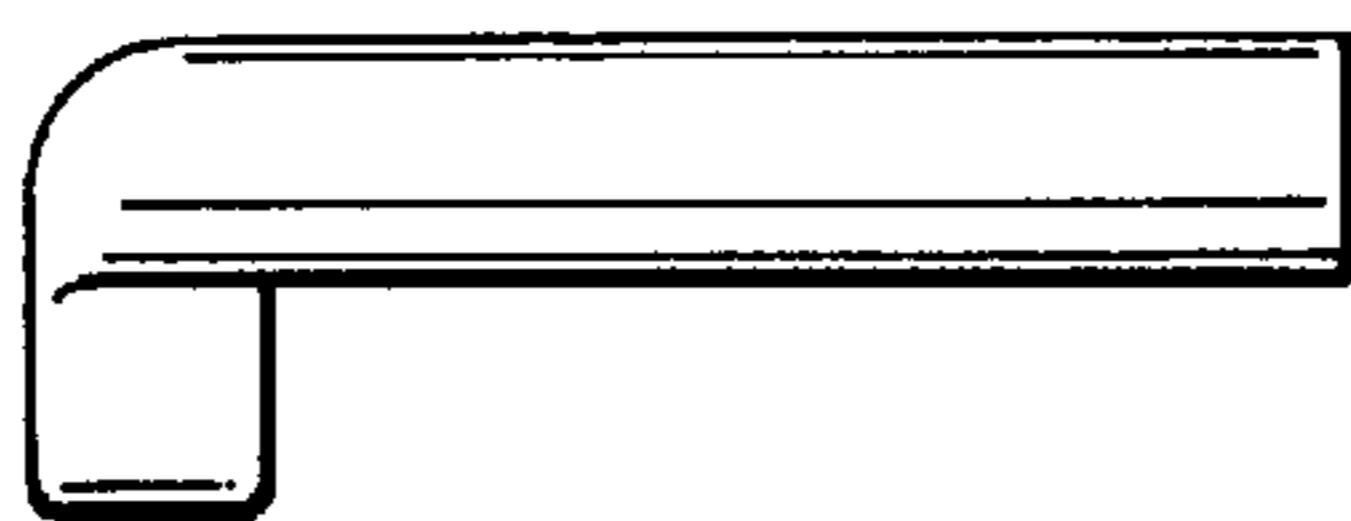

FIG. 9.

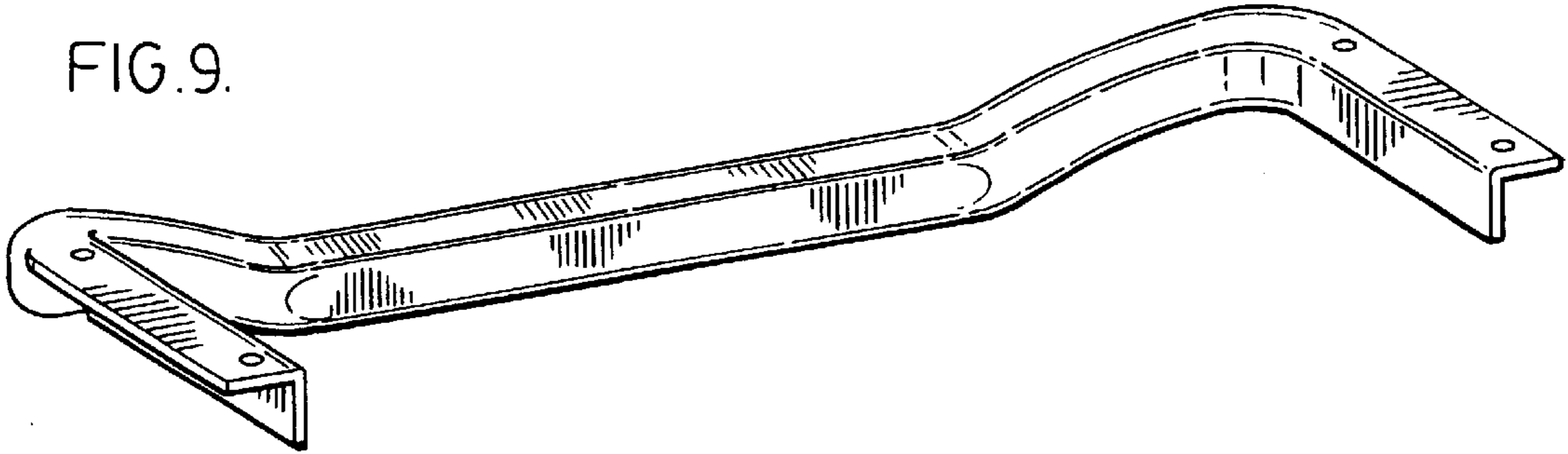

FIG. 10.

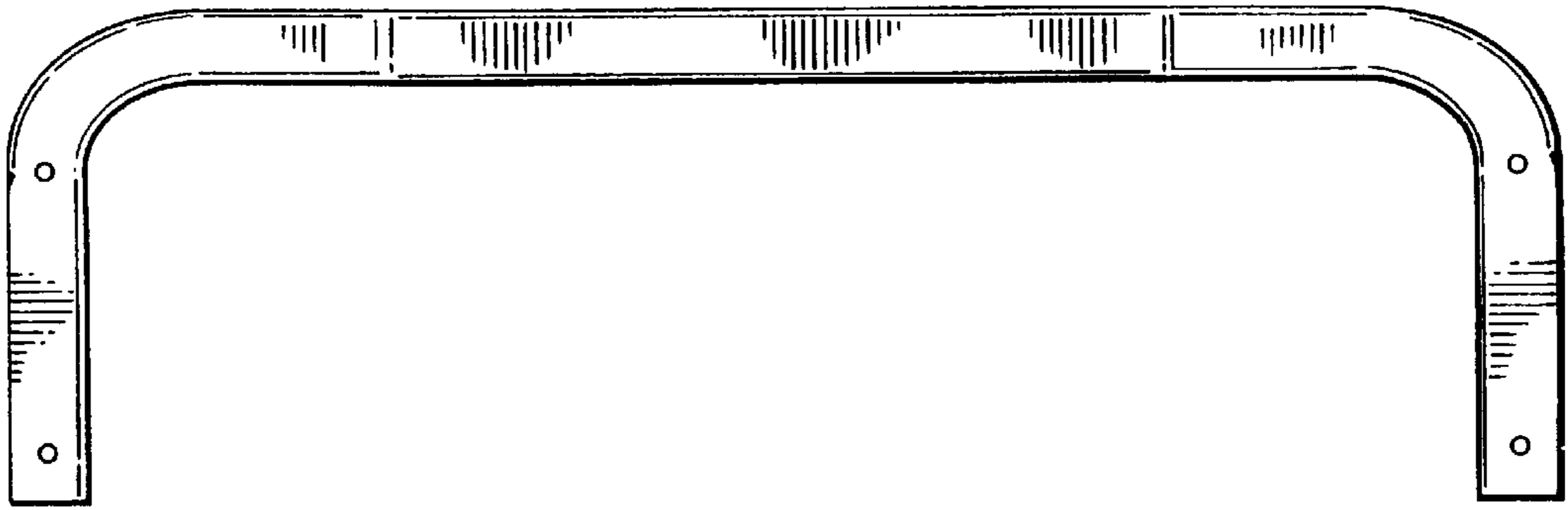

FIG. 11.



FIG. 12.

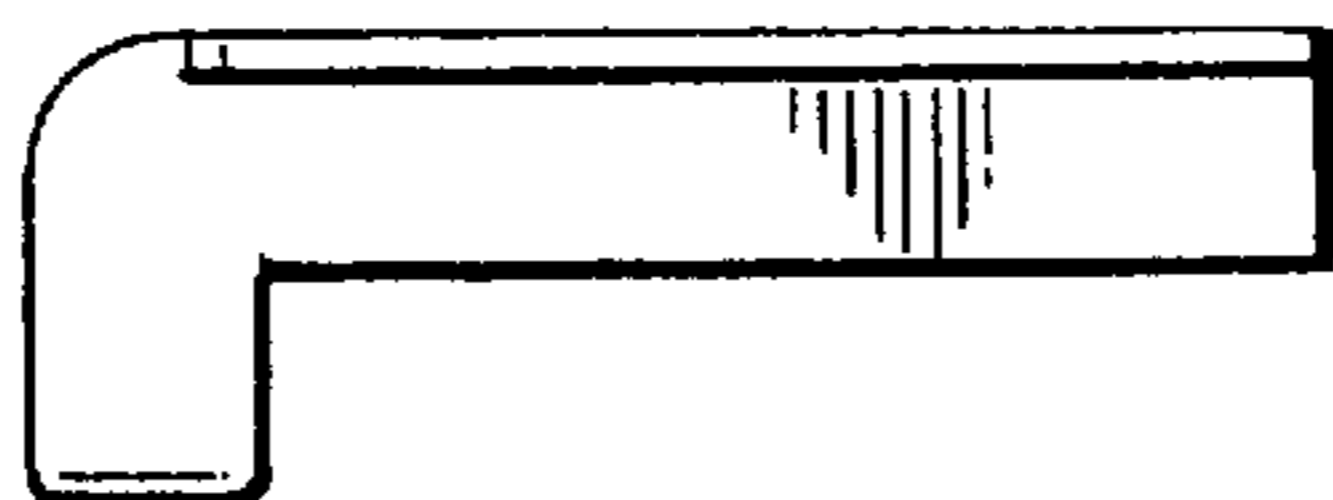

FIG. 13.

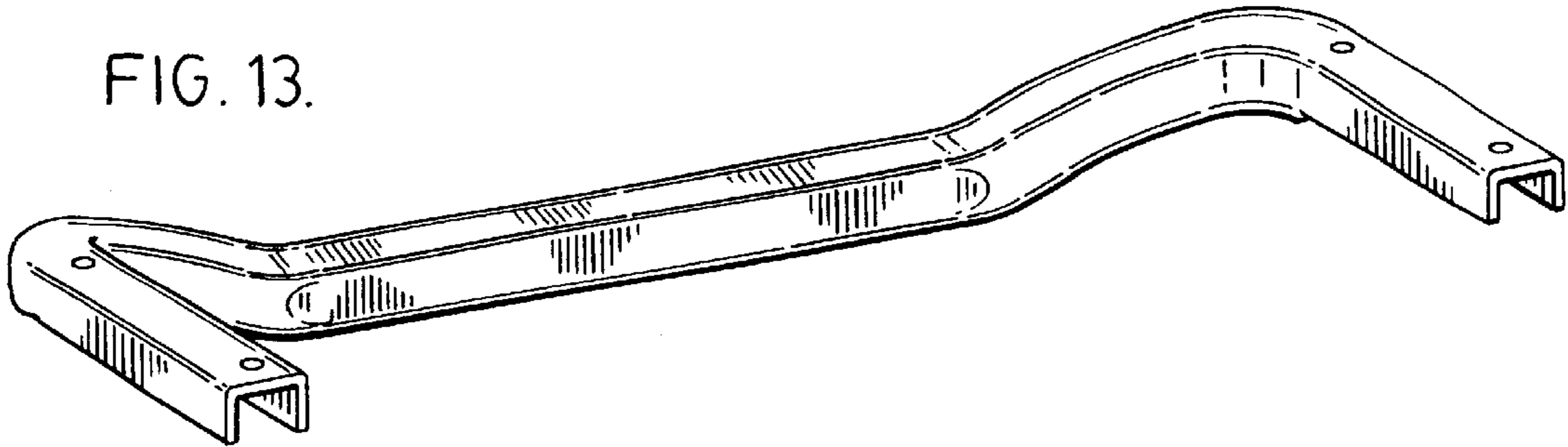

FIG. 14.

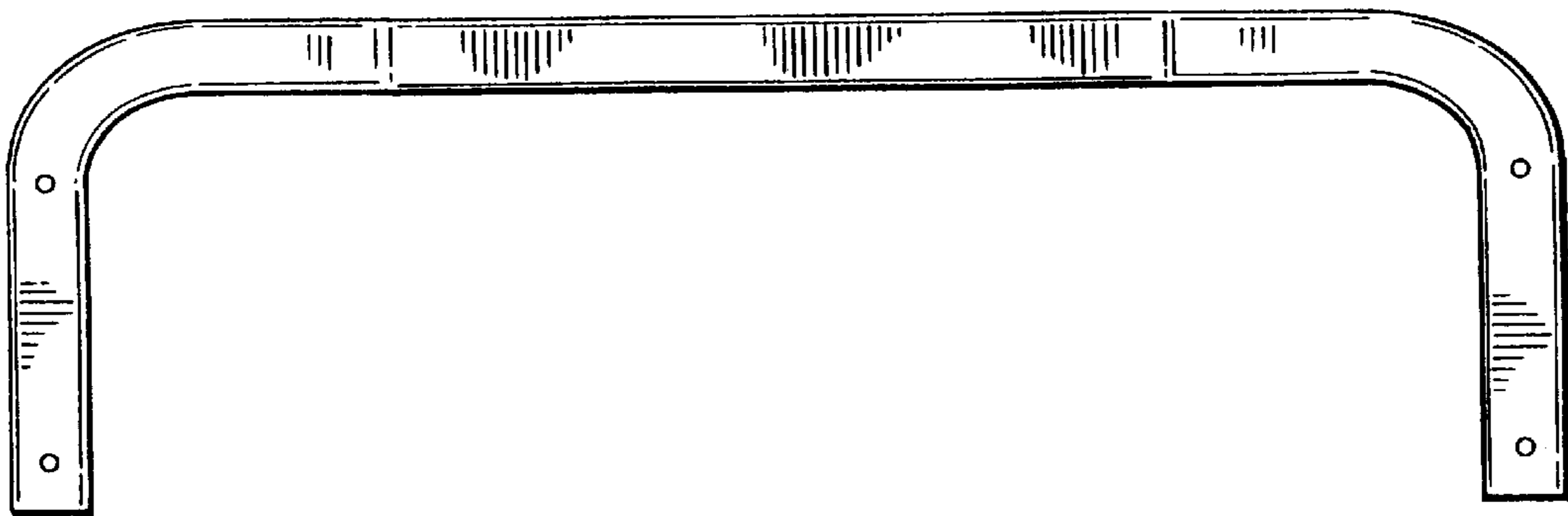

FIG. 15.



FIG. 16.

