



US00D487205S

(12) **United States Design Patent**
Mower et al.

(10) **Patent No.:** **US D487,205 S**

(45) **Date of Patent:** **** *Mar. 2, 2004**

- (54) **EDGE OF A BLOW-MOLDED PLASTIC TABLE TOP**
- (75) Inventors: **Barry Mower**, Layton, UT (US); **Kent Ashby**, Logan, UT (US)
- (73) Assignee: **Lifetime Products, Inc.**, Clearfield, UT (US)
- (*) Notice: This patent is subject to a terminal disclaimer.
- (**) Term: **14 Years**

5,271,338 A	12/1993	Bonham
5,311,825 A	5/1994	Bonham
5,377,601 A	1/1995	Cashen
5,394,808 A	3/1995	Dutro et al.
5,421,272 A	6/1995	Wilmore
5,440,857 A	8/1995	Shanok et al.
5,730,066 A	3/1998	Auten et al.
5,983,807 A	11/1999	Tarnay et al.
D419,332 S	1/2000	Collins et al.
D420,527 S	2/2000	Pinch et al.
6,112,674 A	9/2000	Stanford
6,371,034 B1	4/2002	Simpson et al.
D468,135 S	* 1/2003	Ashby et al. D6/491

* cited by examiner

- (21) Appl. No.: **29/168,302**
- (22) Filed: **Sep. 30, 2002**

Primary Examiner—Janice E. Seeger
(74) *Attorney, Agent, or Firm*—Workman Nydegger

Related U.S. Application Data

(57) **CLAIM**

- (63) Continuation-in-part of application No. 29/154,963, filed on Jan. 18, 2002, now Pat. No. Des. 468,135.
- (51) **LOC (7) Cl.** **06-06**
- (52) **U.S. Cl.** **D6/491; D6/511**
- (58) **Field of Search** D6/491, 480-489, D6/511; D8/403; 108/153.1, 155, 156, 157.1, 161, 65, 27; 312/140.1, 140.2, 140.3; 248/345.1

The ornamental design for an edge of a blow-molded plastic table top, as shown and described.

DESCRIPTION

(56) **References Cited**

U.S. PATENT DOCUMENTS

D192,113 S	*	1/1962	Anderson	D6/511
3,777,673 A	*	12/1973	Blazey et al.	108/27
4,503,780 A	*	3/1985	Apissomian	108/27
4,557,200 A		12/1985	Geschwender		
D288,642 S	*	3/1987	DeLuca	D6/480
D301,953 S	*	7/1989	Evenson	D6/491
4,951,576 A		8/1990	Cobos et al.		

FIG. 1 is a perspective view of an edge of a blow-molded plastic table top of the present invention;
FIG. 2 is an enlarged perspective view of the edge of the blow-molded plastic table top shown in FIG. 1;
FIG. 3 is a top plan view of the edge of the blow-molded plastic table top shown in FIG. 2;
FIG. 4 is a right side view of the edge of the blow-molded plastic table top shown in FIG. 2, and, with the left side view being a mirror image thereof; and,
FIG. 5 is a bottom plan view of the edge of the blow-molded plastic table top shown in FIG. 2.
The broken lines are for environmental purposes only and form no part of the claimed design.

1 Claim, 3 Drawing Sheets

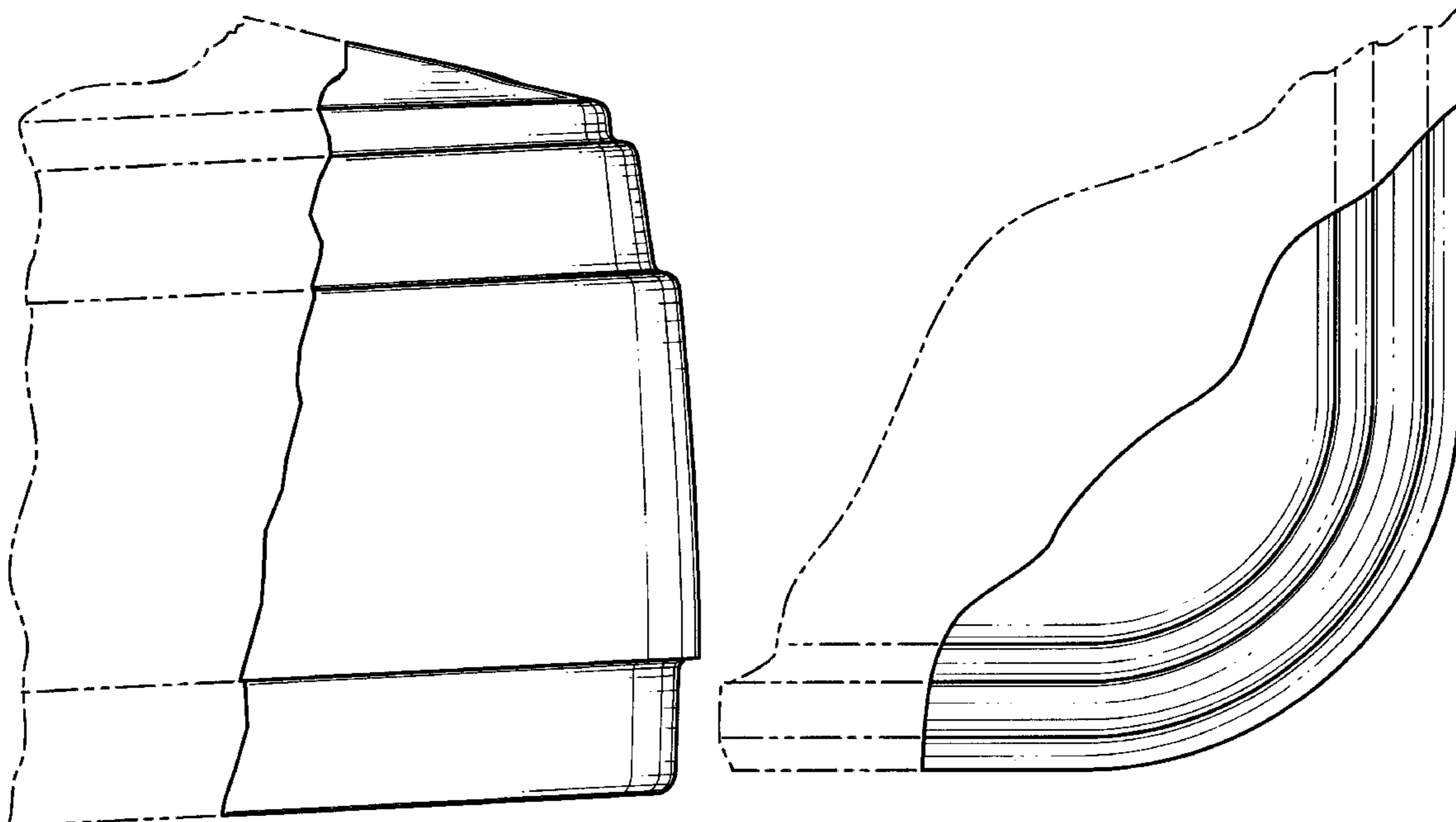

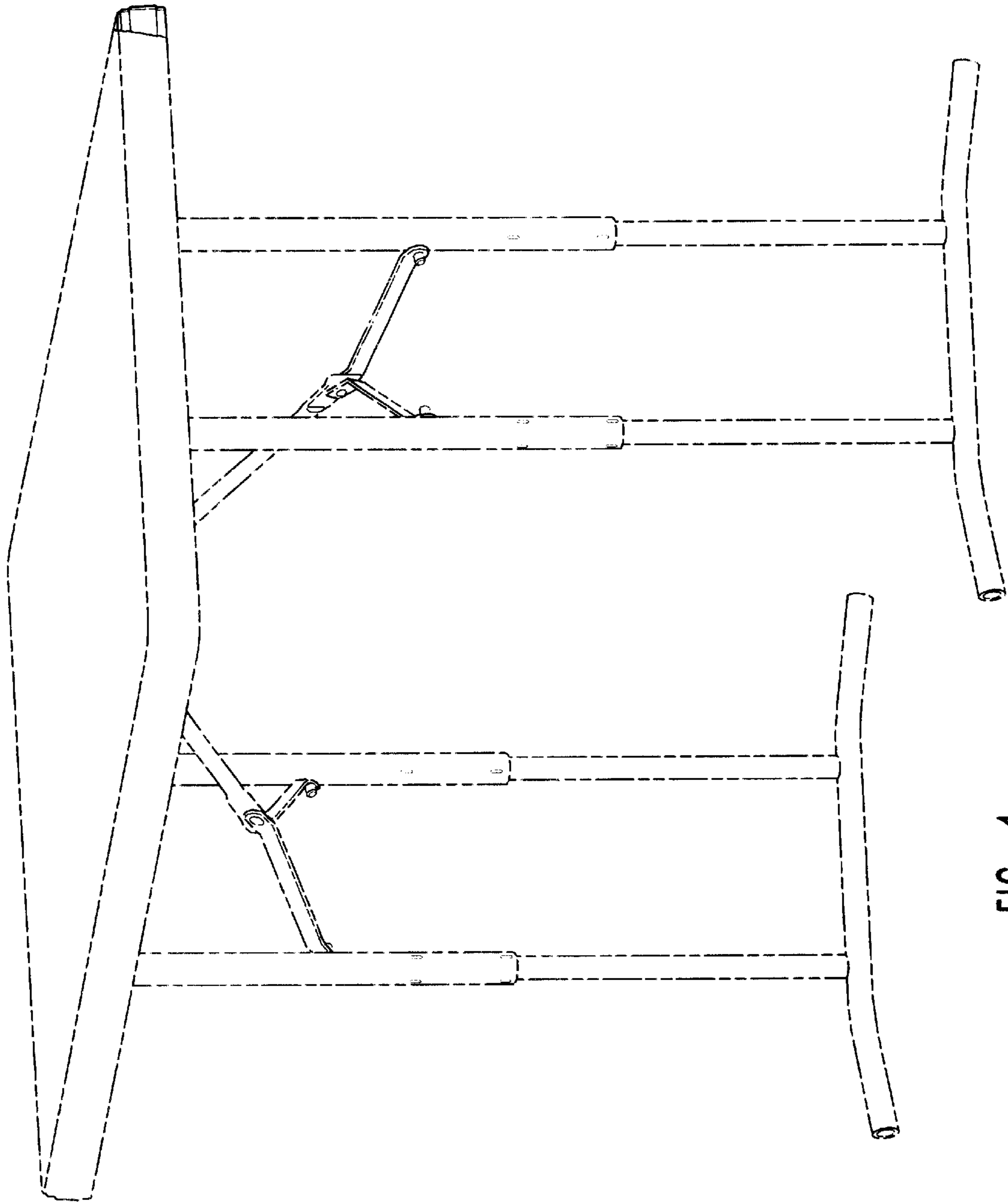

FIG. 1

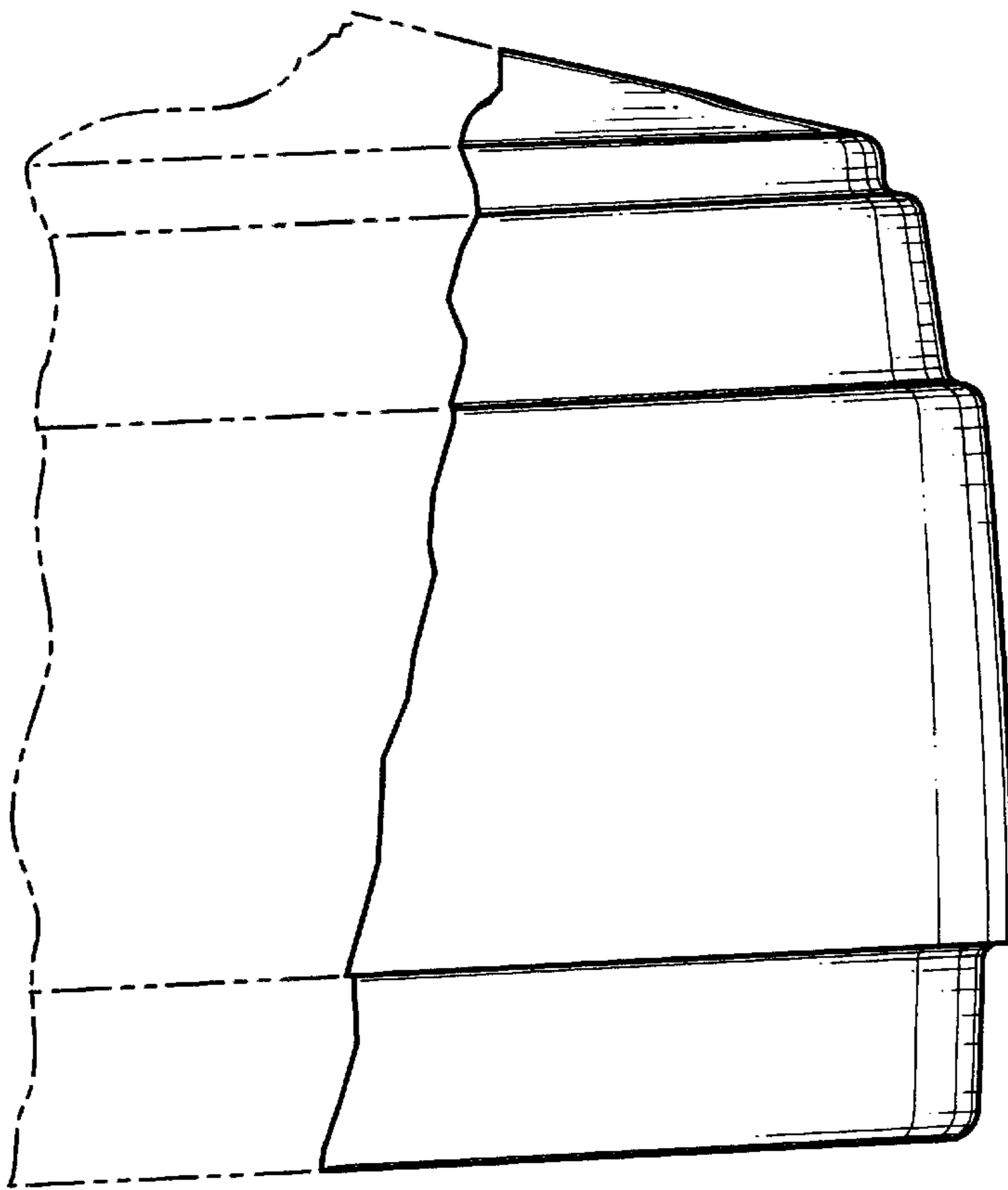

FIG. 2

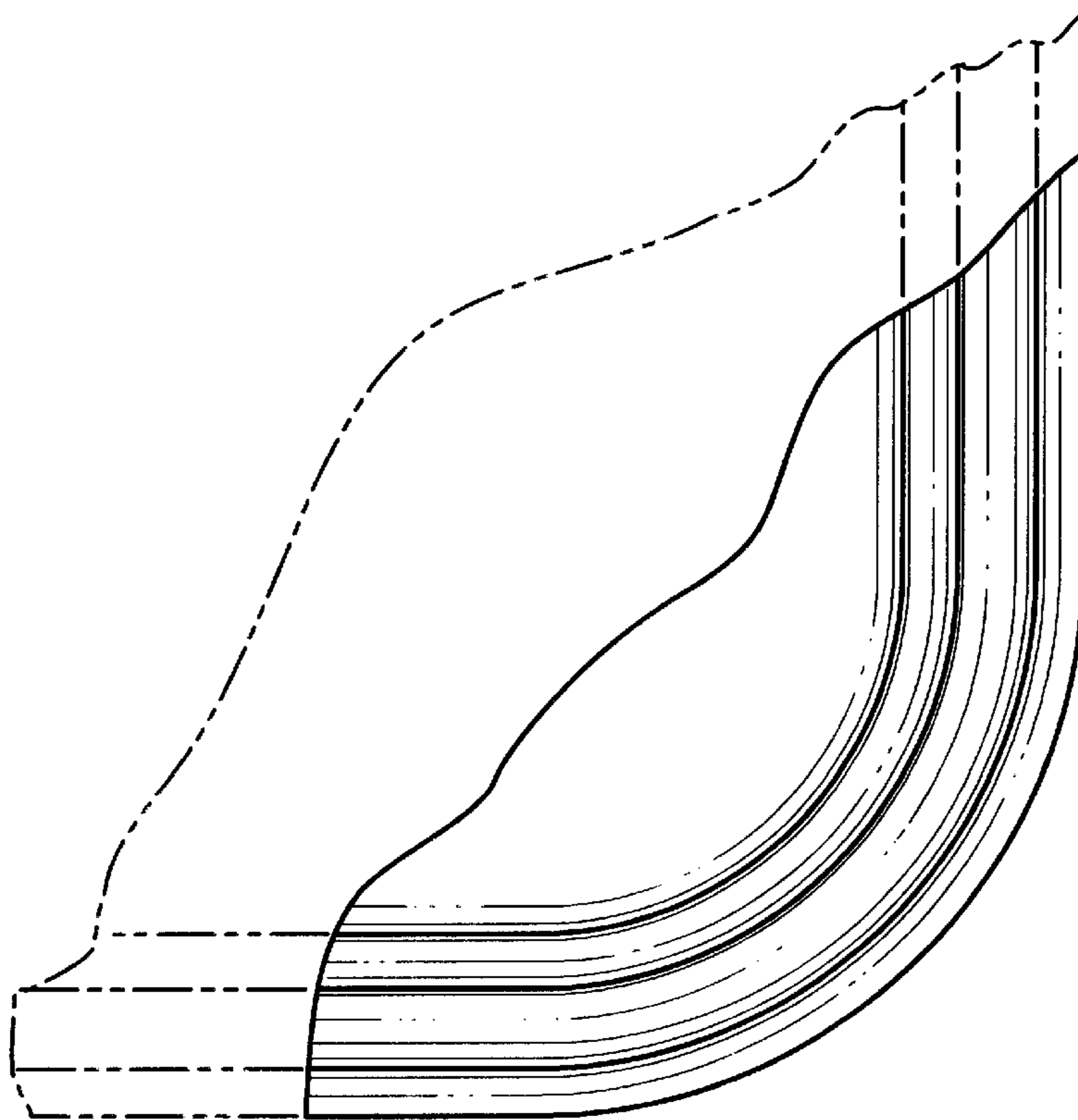

FIG. 3

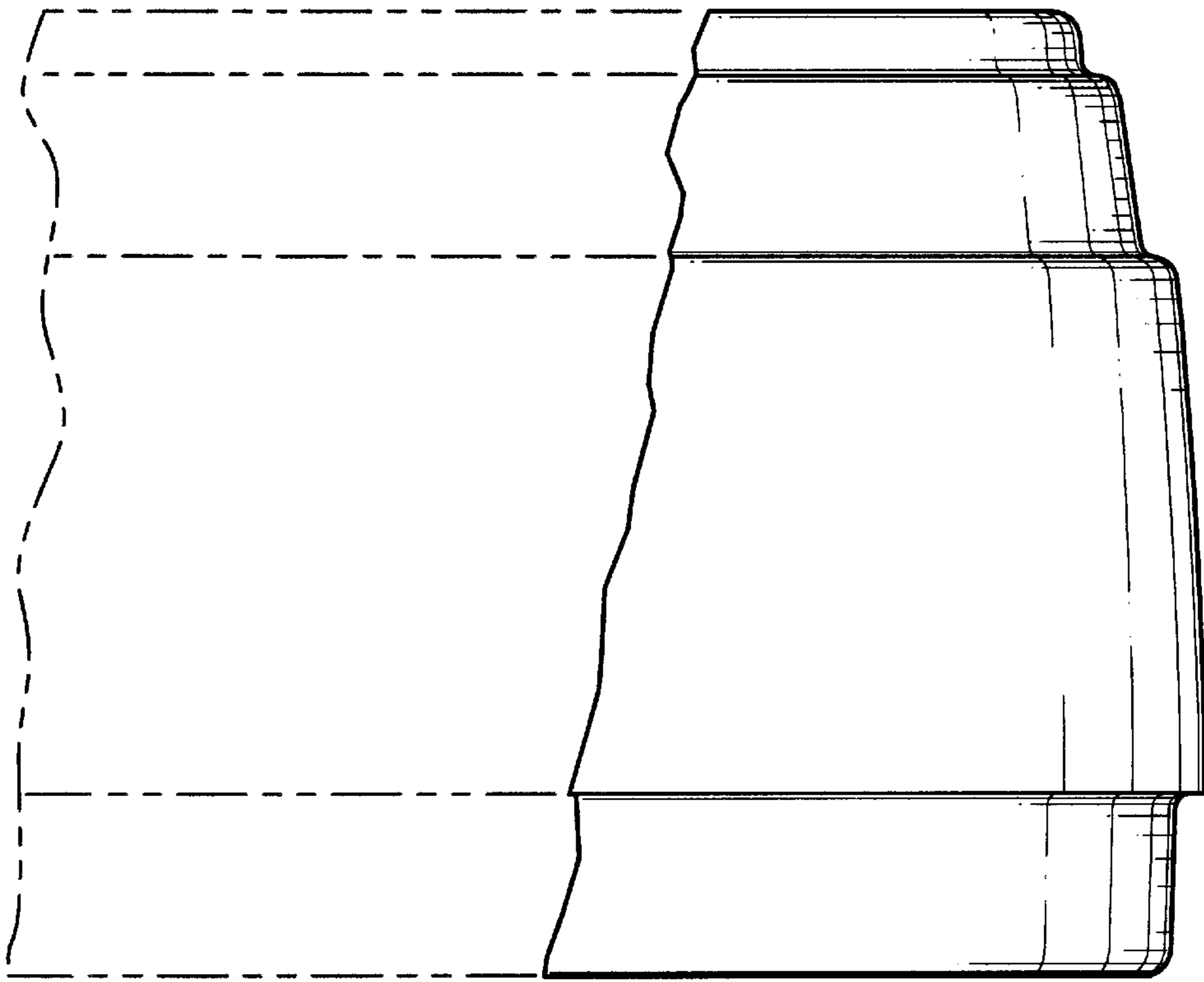

FIG. 4

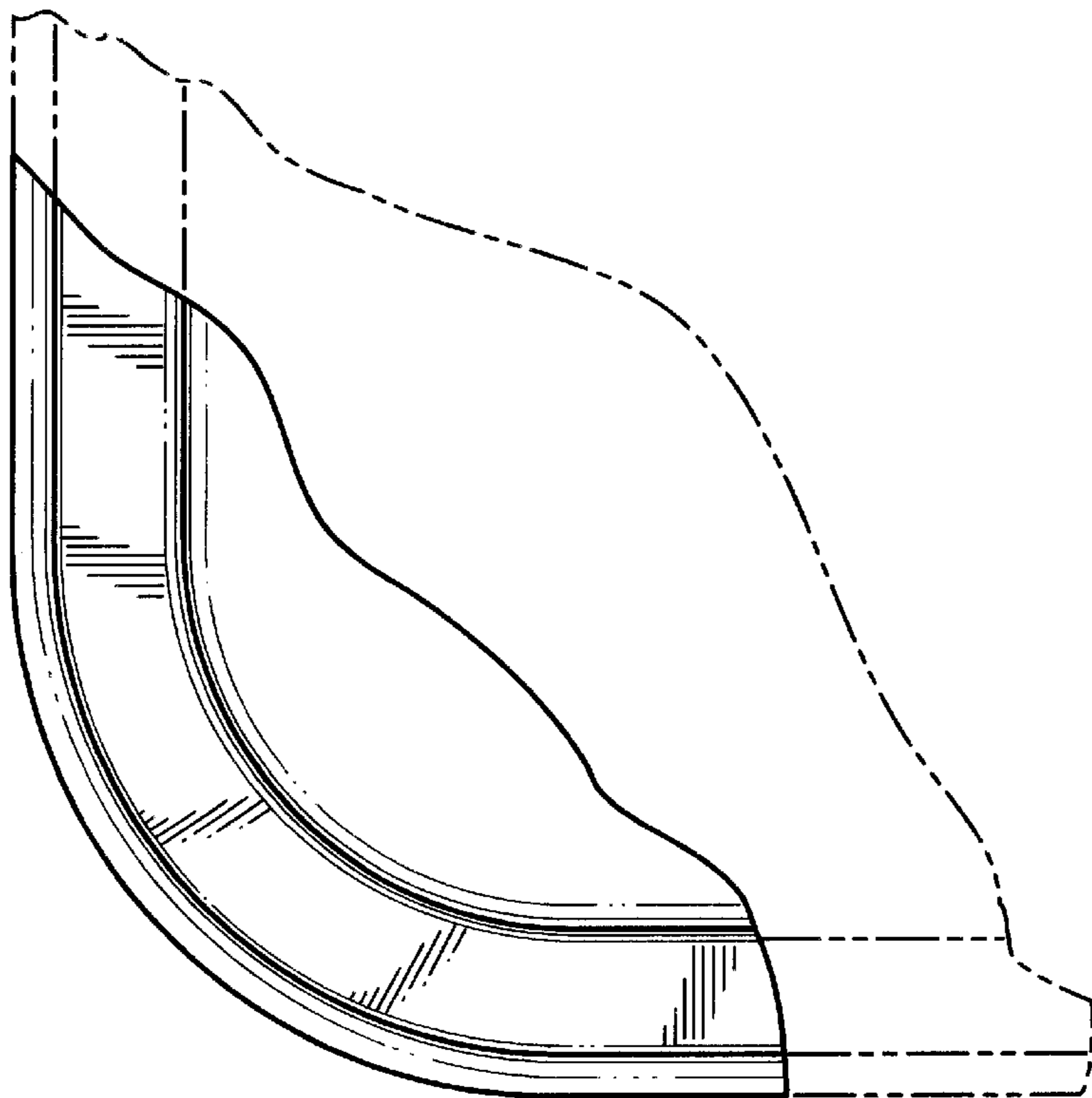

FIG. 5

UNITED STATES PATENT AND TRADEMARK OFFICE
CERTIFICATE OF CORRECTION

PATENT NO. : Des. 487,205 S
DATED : March 2, 2004
INVENTOR(S) : Barry Mower and Kent Ashby

Page 1 of 1

It is certified that error appears in the above-identified patent and that said Letters Patent is hereby corrected as shown below:

Title page,

Description,

Line 8, delete "and"

Line 9, after "and" delete ","

Signed and Sealed this

Twenty-seventh Day of July, 2004

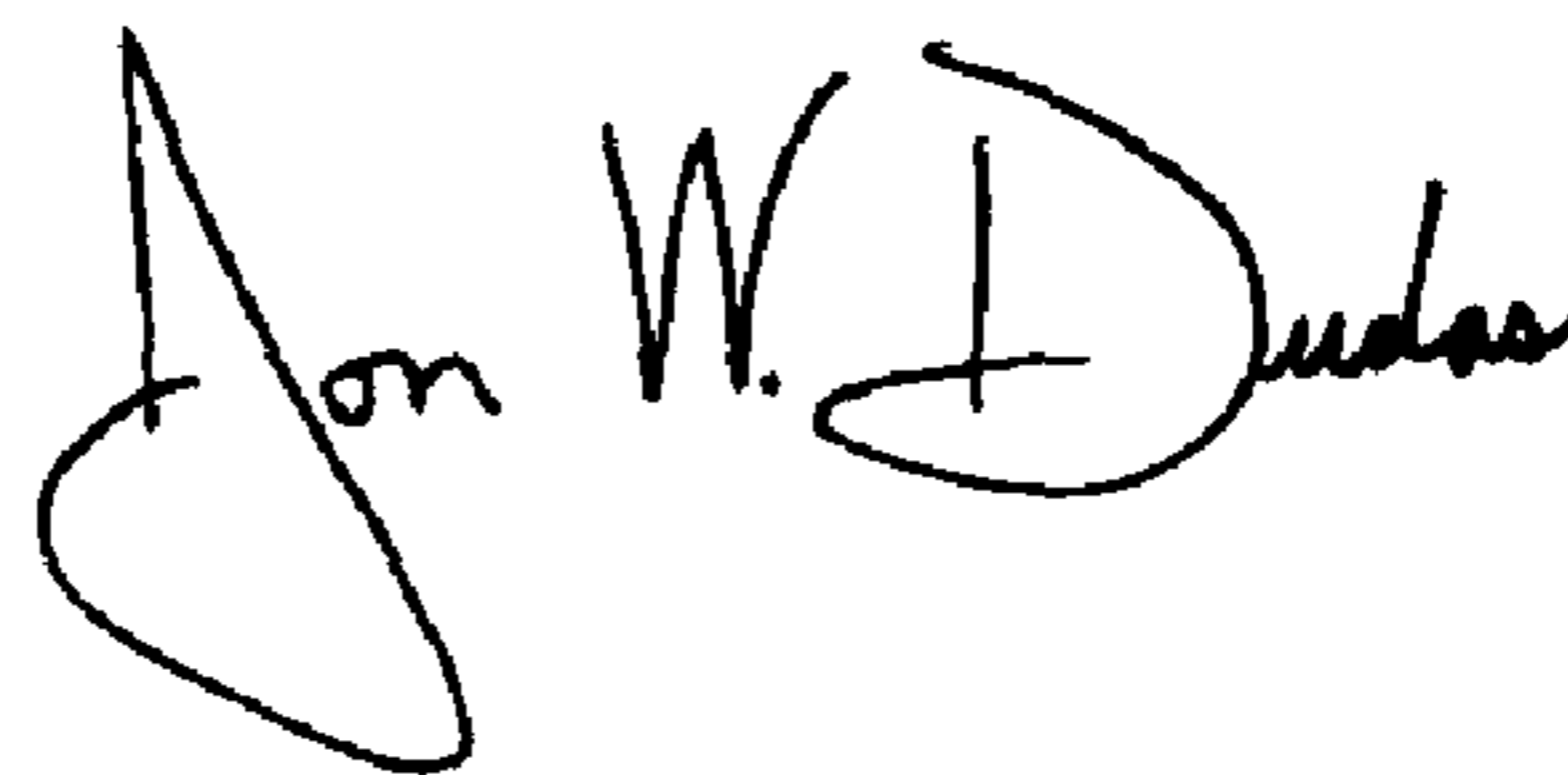
A handwritten signature in black ink that reads "Jon W. Dudas". The signature is written in a cursive style with a large, looped initial "J".

JON W. DUDAS

Acting Director of the United States Patent and Trademark Office