



US00D487147S

(12) **United States Design Patent**
Ellingboe et al.

(10) **Patent No.:** **US D487,147 S**

(45) **Date of Patent:** **** Feb. 24, 2004**

(54) **MALE CONNECTOR IN A PATIENT TEMPERATURE CONTROL SYSTEM**

(75) Inventors: **Bruce Ellingboe**, Littleton, CO (US);
Michael R. Høglund, Mead, CO (US);
Gary A. Carson, Golden, CO (US)

(73) Assignee: **Medivance Incorporated**, Louisville, CO (US)

(**) Term: **14 Years**

(21) Appl. No.: **29/165,347**

(22) Filed: **Aug. 8, 2002**

(51) **LOC (7) Cl.** **23-01**

(52) **U.S. Cl.** **D24/129**

(58) **Field of Search** D24/129, 206,
D24/200; 607/104, 107, 108, 112; 137/614.04;
D23/262

(56) **References Cited**

U.S. PATENT DOCUMENTS

998,804 A	7/1911	Salisbury	
2,224,876 A	12/1940	Matys	34/26
2,250,325 A	7/1941	Barnes	257/12
2,416,788 A	3/1947	Andrews	34/99
2,566,600 A	9/1951	Colon	128/65
2,726,658 A	12/1955	Chessey	128/400
3,064,649 A	11/1962	Fuson	128/214
3,460,538 A	8/1969	Armstrong	128/303.1
3,504,674 A	4/1970	Swenson et al.	128/303.1
3,894,213 A	7/1975	Agarwala	219/297
4,118,946 A	10/1978	Tubin	128/24.1
4,149,529 A	4/1979	Copeland et al.	128/24.1
T994,001 I4	5/1980	Buckberg et al.	128/214
4,259,961 A	4/1981	Hood, III	128/400
4,338,944 A	7/1982	Arkans	128/400
4,416,280 A	11/1983	Carpenter et al.	128/399
4,427,009 A	1/1984	Wells et al.	128/400
4,459,468 A	7/1984	Bailey	219/490
4,508,123 A	4/1985	Wyatt et al.	128/692
4,512,163 A	4/1985	Wells et al.	62/394
4,691,762 A	9/1987	Elkins et al.	165/46

4,844,072 A	7/1989	French et al.	128/400
4,919,134 A	4/1990	Streeter	128/400
4,962,761 A	10/1990	Golden	128/400
4,987,618 A	1/1991	Tolbert	4/515
5,051,562 A	9/1991	Bailey et al.	219/506
5,097,829 A	3/1992	Quisenberry	128/400
5,165,127 A	11/1992	Nicholson	5/421
5,190,032 A	3/1993	Zacoi	128/400
5,270,005 A	12/1993	Raible	422/46
5,304,213 A	4/1994	Berke et al.	607/104
D347,491 S	5/1994	Holloway	D28/20
5,344,436 A	9/1994	Fontenot et al.	607/104
5,411,541 A	5/1995	Bell et al.	607/104

(List continued on next page.)

Primary Examiner—Ian Simmons

(74) *Attorney, Agent, or Firm*—Marsh Fischmann & Breyfogle LLP

(57) **CLAIM**

The ornamental design for a male connector in a patient temperature control system, as shown and described.

DESCRIPTION

FIG. 1 is a perspective view of the male connector in a patient temperature control system;
 FIG. 2 is a front view of the male connector in a patient temperature control system;
 FIG. 3 is a back view of the male connector in a patient temperature control system;
 FIG. 4 is a right side view of the male connector in a patient temperature control system;
 FIG. 5 is a left side view of the male connector in a patient temperature control system;
 FIG. 6 is a top view of the male connector in a patient temperature control system; and,
 FIG. 7 is a bottom view of the male connector in a patient temperature control system.
 The broken line showing in the FIGS. 1 through 7 are for illustrative purposes only and forms no part of the claimed design.

1 Claim, 2 Drawing Sheets

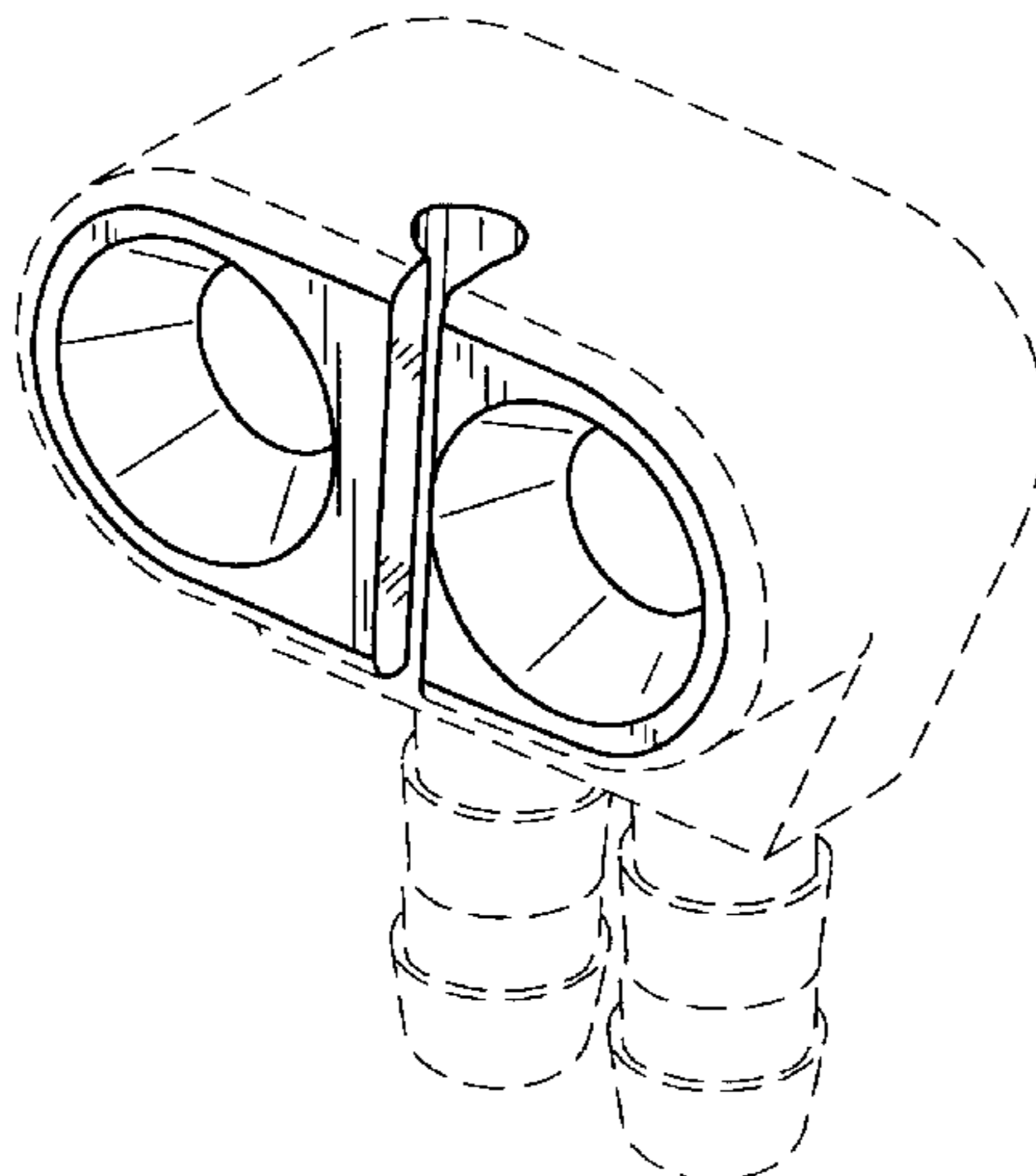

US D487,147 S

Page 2

U.S. PATENT DOCUMENTS

5,456,701 A	*	10/1995	Stout	607/104	5,800,486 A	9/1998	Thome et al.	607/105
D364,680 S	*	11/1995	Dye	D24/129	5,830,214 A	11/1998	Flom et al.	606/41
5,466,216 A		11/1995	Brown et al.	604/33	5,865,841 A	2/1999	Kolen et al.	607/104
5,466,250 A		11/1995	Johnson, Jr. et al.	607/104	5,895,418 A	4/1999	Saringer	607/104
5,470,353 A		11/1995	Jensen	607/104	5,957,879 A	9/1999	Roberts et al.	604/4
5,486,207 A		1/1996	Mahawili	607/104	5,980,561 A	11/1999	Kolen et al.	607/104
5,496,357 A		3/1996	Jensen et al.	607/108	5,997,816 A	12/1999	McIntosh et al.	422/44
5,507,792 A		4/1996	Mason et al.	607/104	6,074,389 A	6/2000	Levine et al.	606/45
5,609,571 A		3/1997	Buckberg et al.	604/4	6,086,609 A	7/2000	Buckley	607/104
5,609,620 A		3/1997	Daily	607/105	6,117,164 A	9/2000	Gildersleeve et al.	607/108
5,634,940 A		6/1997	Panyard	607/104	6,149,620 A	11/2000	Baker et al.	604/22
5,640,728 A		6/1997	Graebe	5/606	6,149,674 A	11/2000	Borders	607/96
5,643,191 A		7/1997	Buckberg et al.	604/4	6,197,045 B1	3/2001	Carson	607/104
5,702,358 A		12/1997	Witherspoon et al.	604/4	6,206,876 B1	3/2001	Levine et al.	606/45
5,730,720 A		3/1998	Sites et al.	604/27	6,238,427 B1	5/2001	Matta	607/104

* cited by examiner

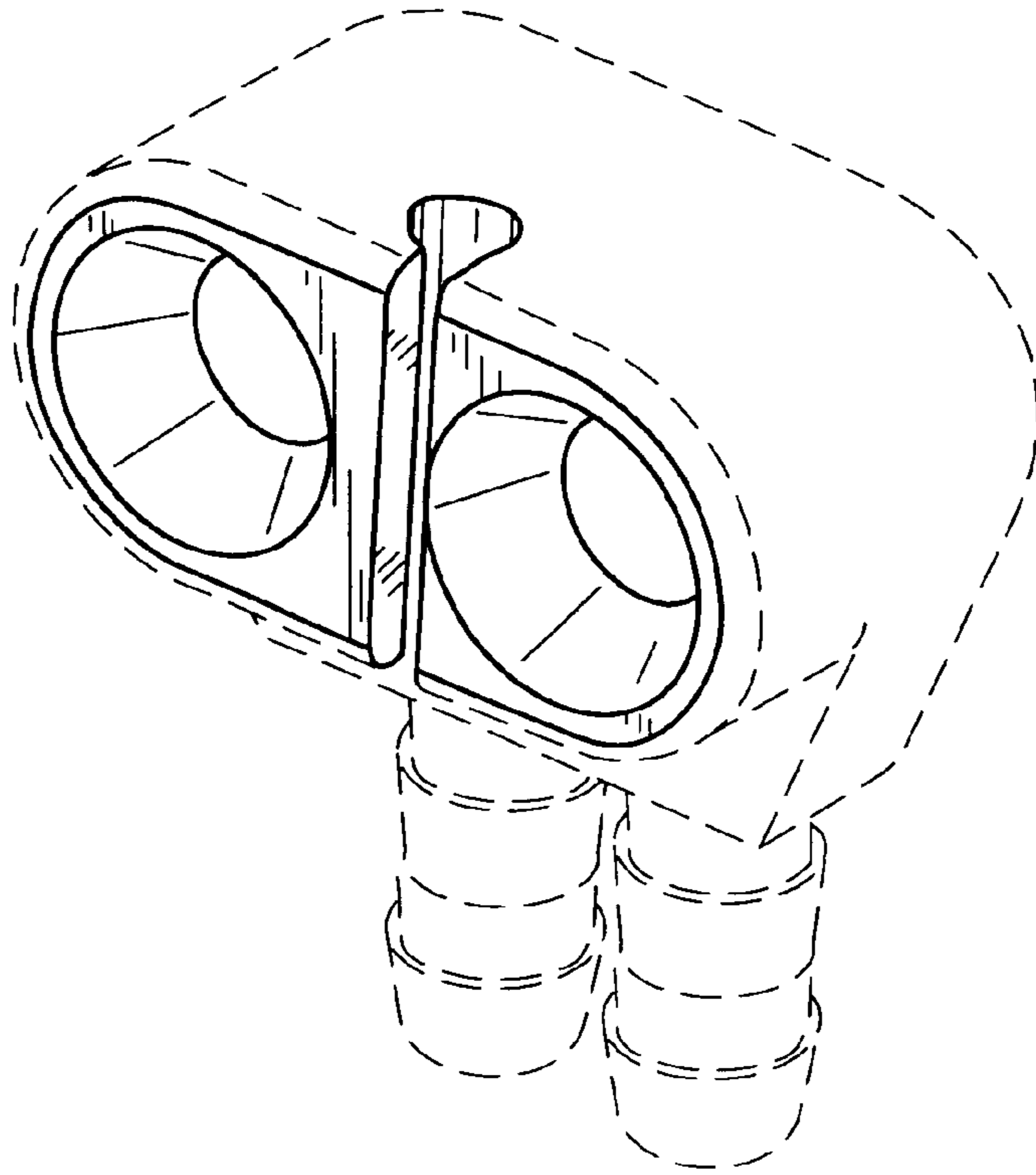

FIG. 1

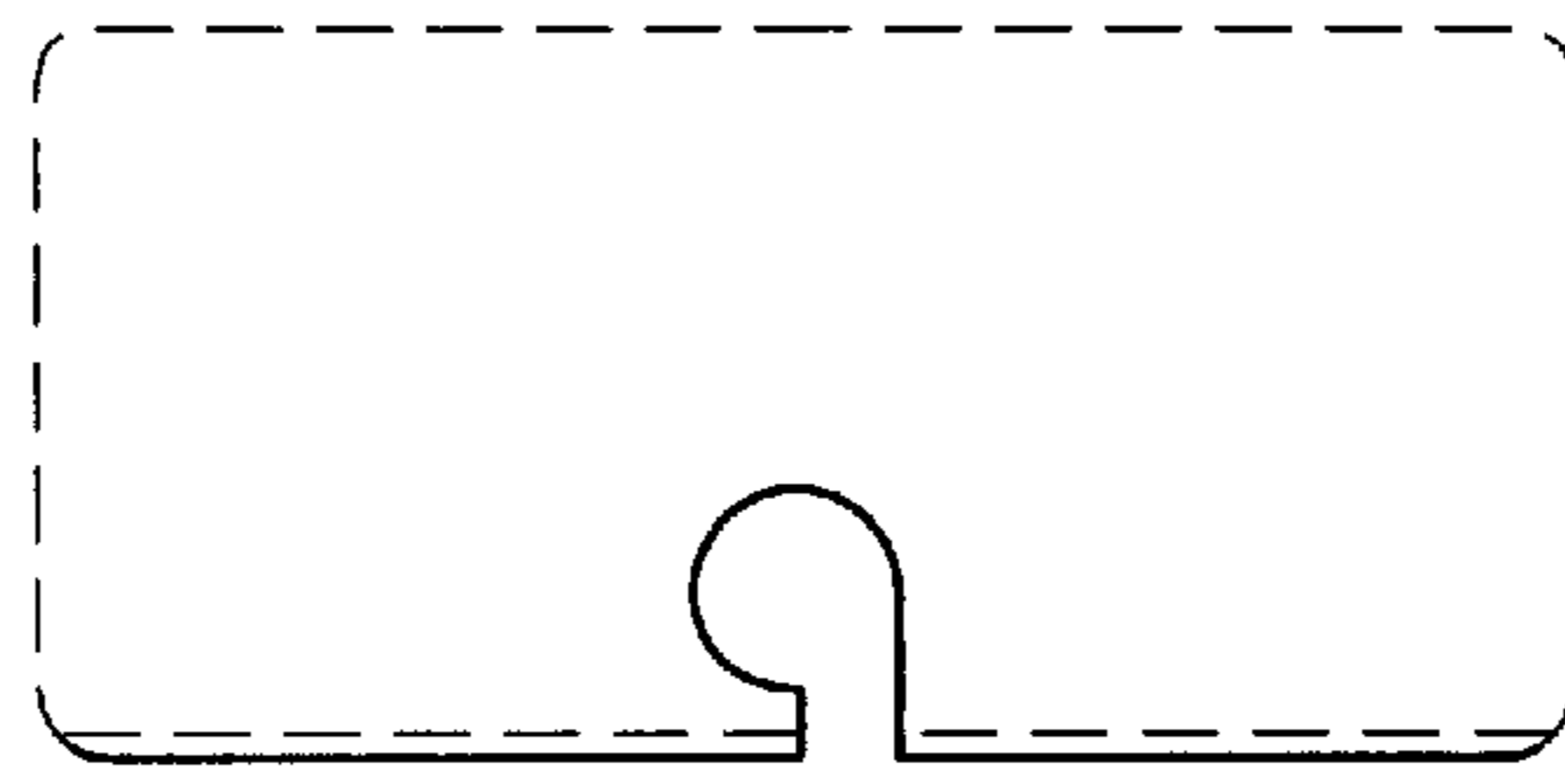

FIG. 6

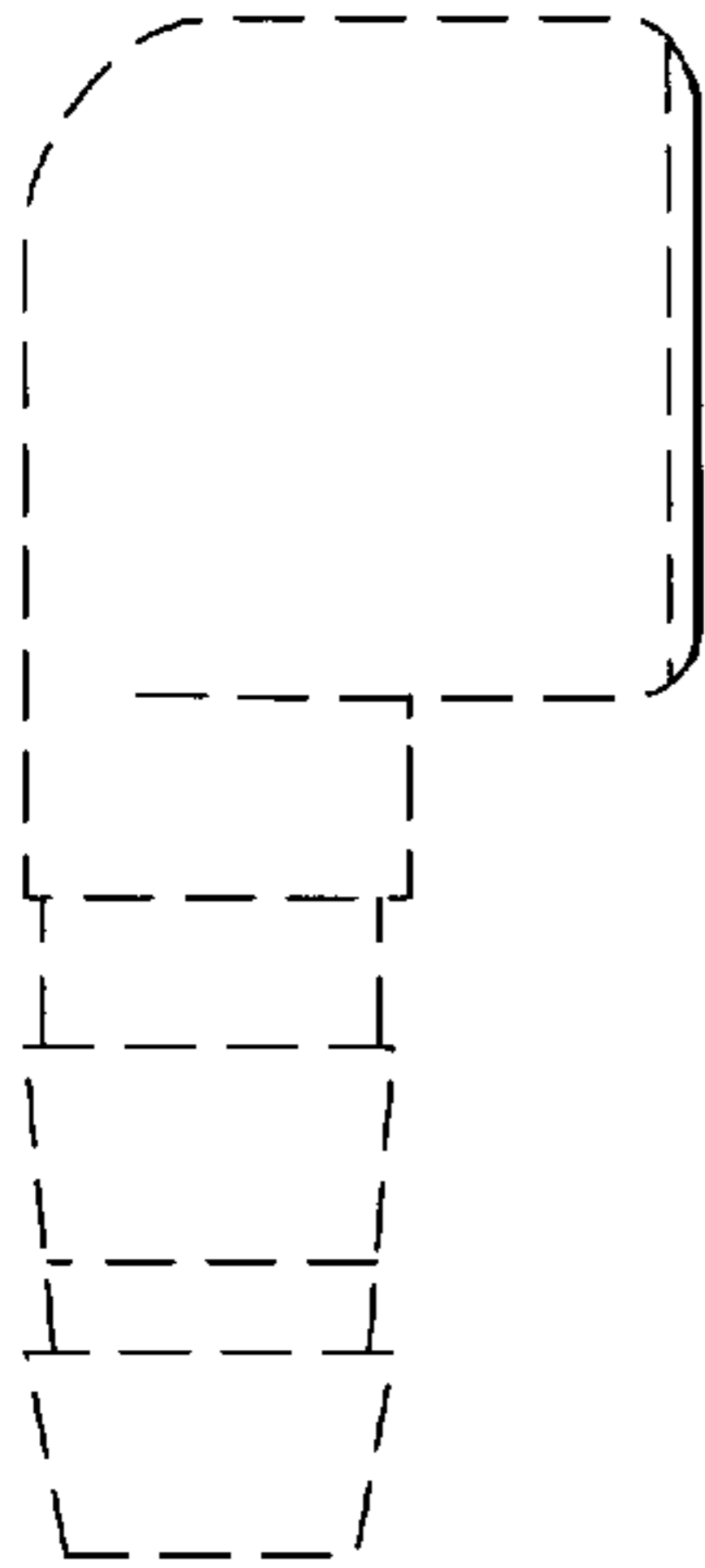

FIG. 5

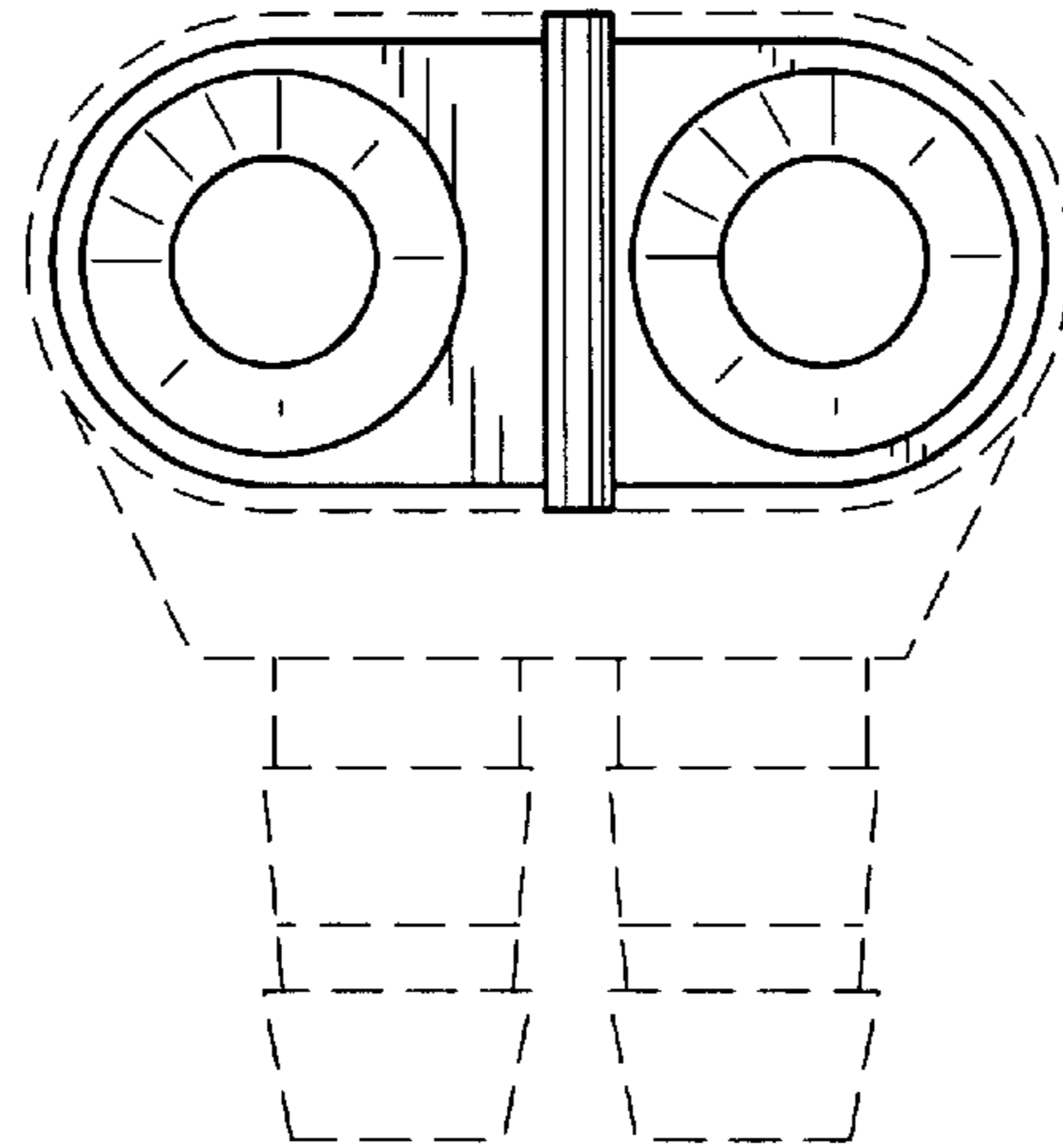

FIG. 2

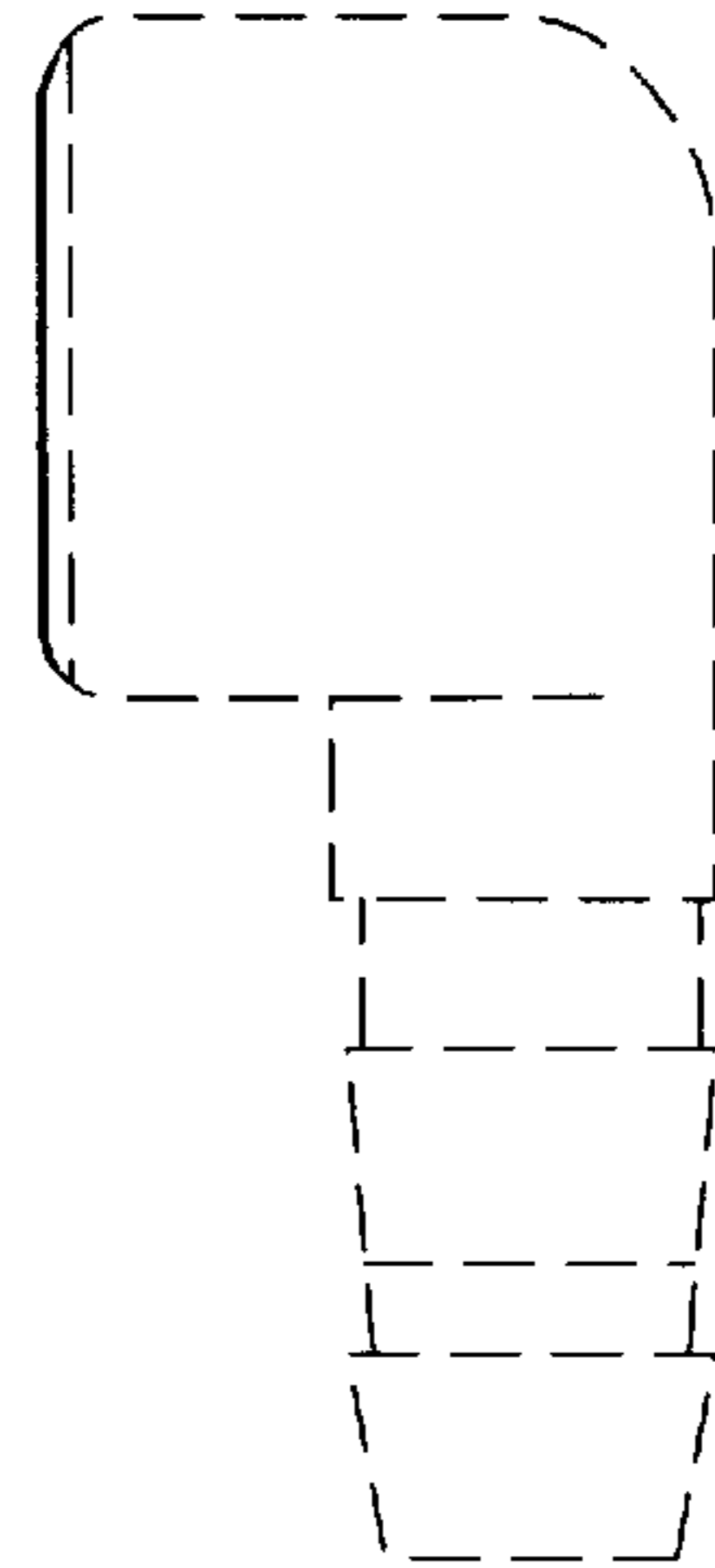

FIG. 4

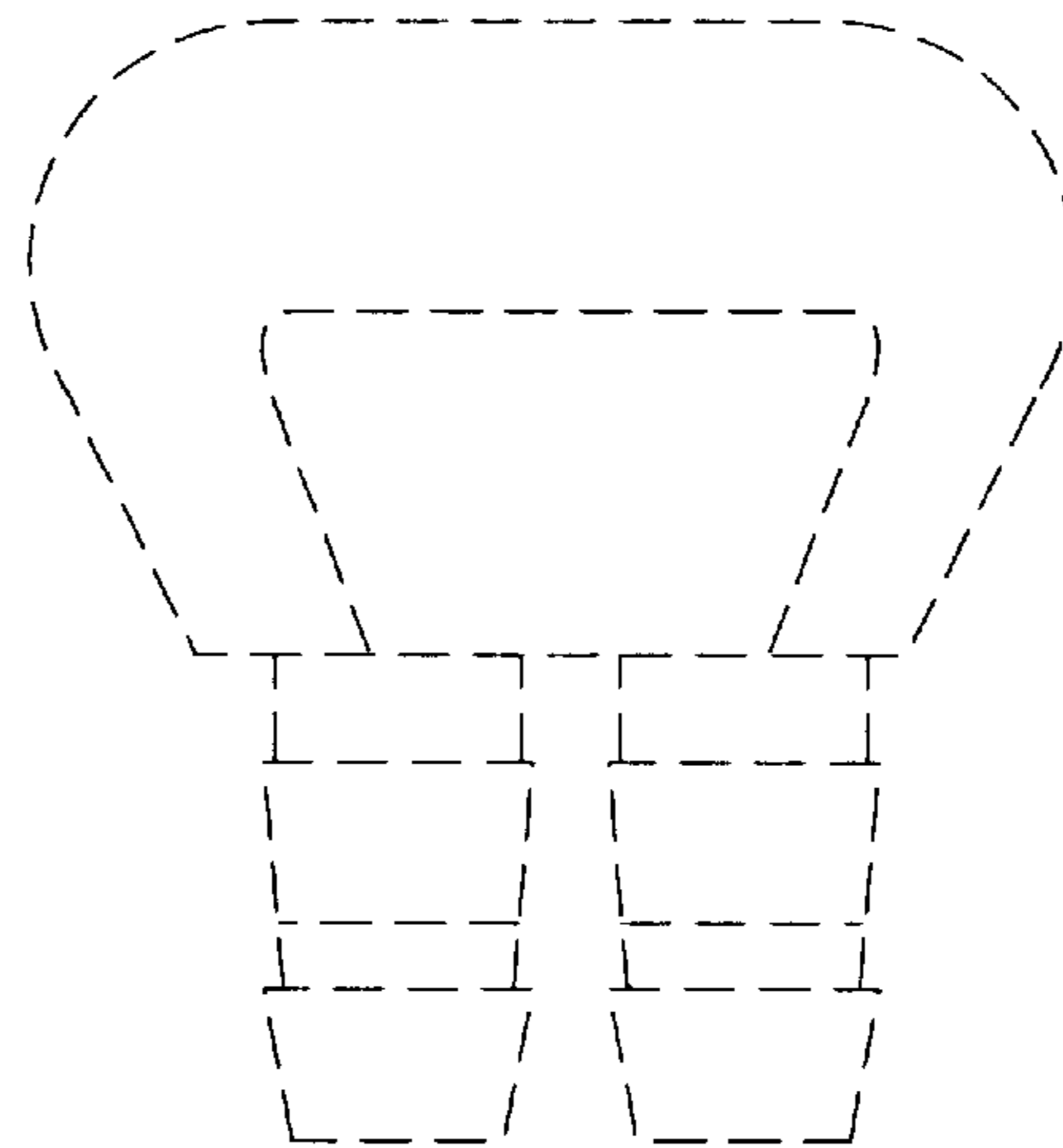

FIG. 3

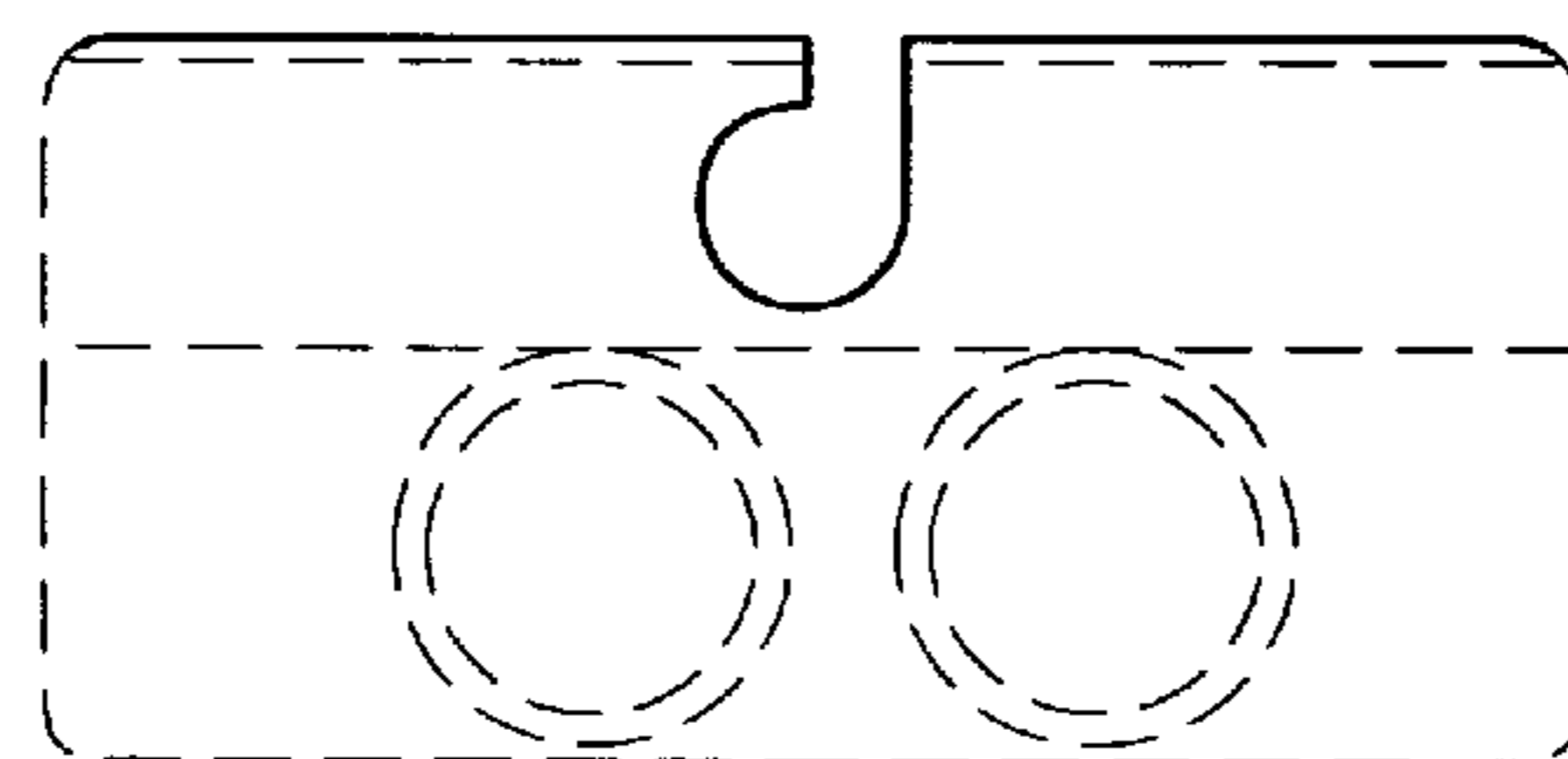

FIG. 7