



US00D487041S

(12) **United States Design Patent**
Schlachter

(10) **Patent No.:** **US D487,041 S**

(45) **Date of Patent:** **** Feb. 24, 2004**

(54) **SKID PLATE**

D474,726 S * 5/2003 Weber et al. D12/196

(75) Inventor: **Mark David Schlachter**, Covington, KY (US)

(73) Assignee: **Dean's Dream Ltd.**, Cincinnati, OH (US)

(**) Term: **14 Years**

(21) Appl. No.: **29/178,561**

(22) Filed: **Mar. 27, 2003**

(51) **LOC (7) Cl.** **12-16**

(52) **U.S. Cl.** **D12/196**

(58) **Field of Search** D12/196, 181, D12/190, 191, 163, 169, 86, 90-92, 400; 296/180.1, 180.2; 293/102, 113, 115

(56) **References Cited**

U.S. PATENT DOCUMENTS

D398,264 S	*	9/1998	Fetz et al.	D12/97
D401,890 S		12/1998	Larson et al.	D12/91
D431,796 S		10/2000	Lagaay et al.	D12/92
D435,815 S		1/2001	Larson	D12/169
D435,817 S		1/2001	Lai	D12/181
D436,061 S		1/2001	Möbius et al.	D12/92
D437,812 S		2/2001	Lai	D12/169
D438,145 S		2/2001	Hatter	D12/92
D438,146 S		2/2001	Larson	D12/107
D438,497 S		3/2001	Yokomaku	D12/190
D448,710 S		10/2001	Akana et al.	D12/196
D449,254 S		10/2001	Larson	D12/92
D455,382 S		4/2002	Gallitzendoerfer et al.	D12/196
D458,562 S	*	6/2002	Kalhok et al.	D12/107
D460,933 S		7/2002	Newton	D12/163
D460,935 S		7/2002	Newton	D12/196
D466,063 S		11/2002	Schlachter	D12/196
D469,393 S		1/2003	Schlachter	D12/196

OTHER PUBLICATIONS

Brochure: "Days gone by mark day to come".
 Brochure: "... an extraordinary 550 Spyder-inspired Boxster . . .".
 Web pages from <http://www.deansdream.net>, posted Jan. 28, 2002.
 Mark Schlachter, Dean's Dream, *Bent Pylon*; Ohio Valley Region / Porsche Club of America; Sep. 2001.
911 & Porsche World; Apr. 2002.
 Keith Seume, Past Master, *911 & Porsche World*; May 2002.

* cited by examiner

Primary Examiner—Melody N. Brown
 (74) *Attorney, Agent, or Firm*—Wood, Herron & Evans, LLP

(57) **CLAIM**

The ornamental design for a skid plate, as shown and described.

DESCRIPTION

FIG. 1 is a perspective view from the right side of a skid plate showing my design.
 FIG. 2 is a top view of the skid plate design shown in FIG. 1.
 FIG. 3 is a left side view of the skid plate design shown in FIG. 1, the right side view being a mirror image thereof.
 FIG. 4 is a front view of the skid plate design shown in FIG. 1.
 FIG. 5 is a rear view of the skid plate design shown in FIG. 1; and,
 FIG. 6 is a bottom view of the skid plate design shown in FIG. 1.

1 Claim, 2 Drawing Sheets

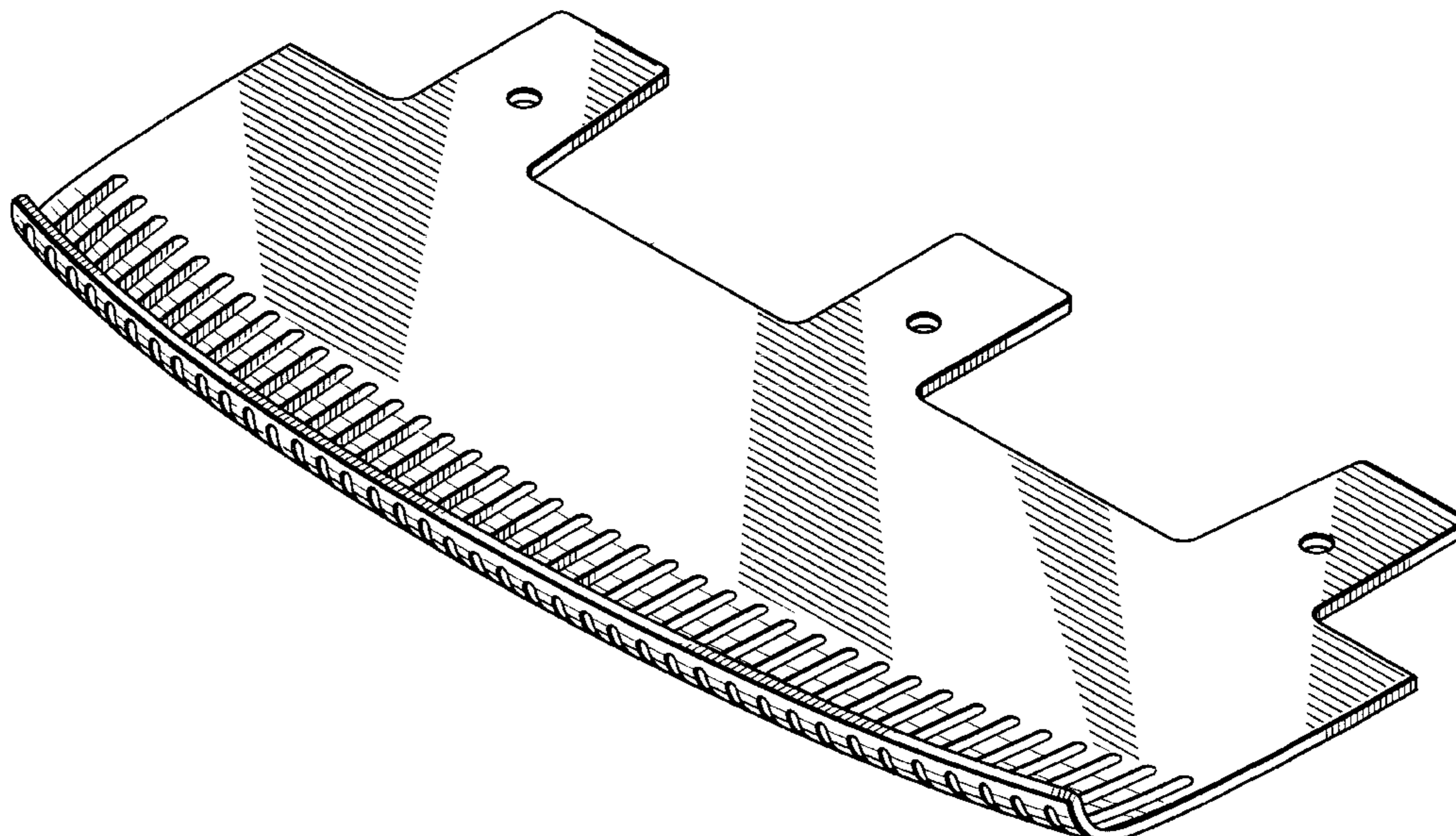

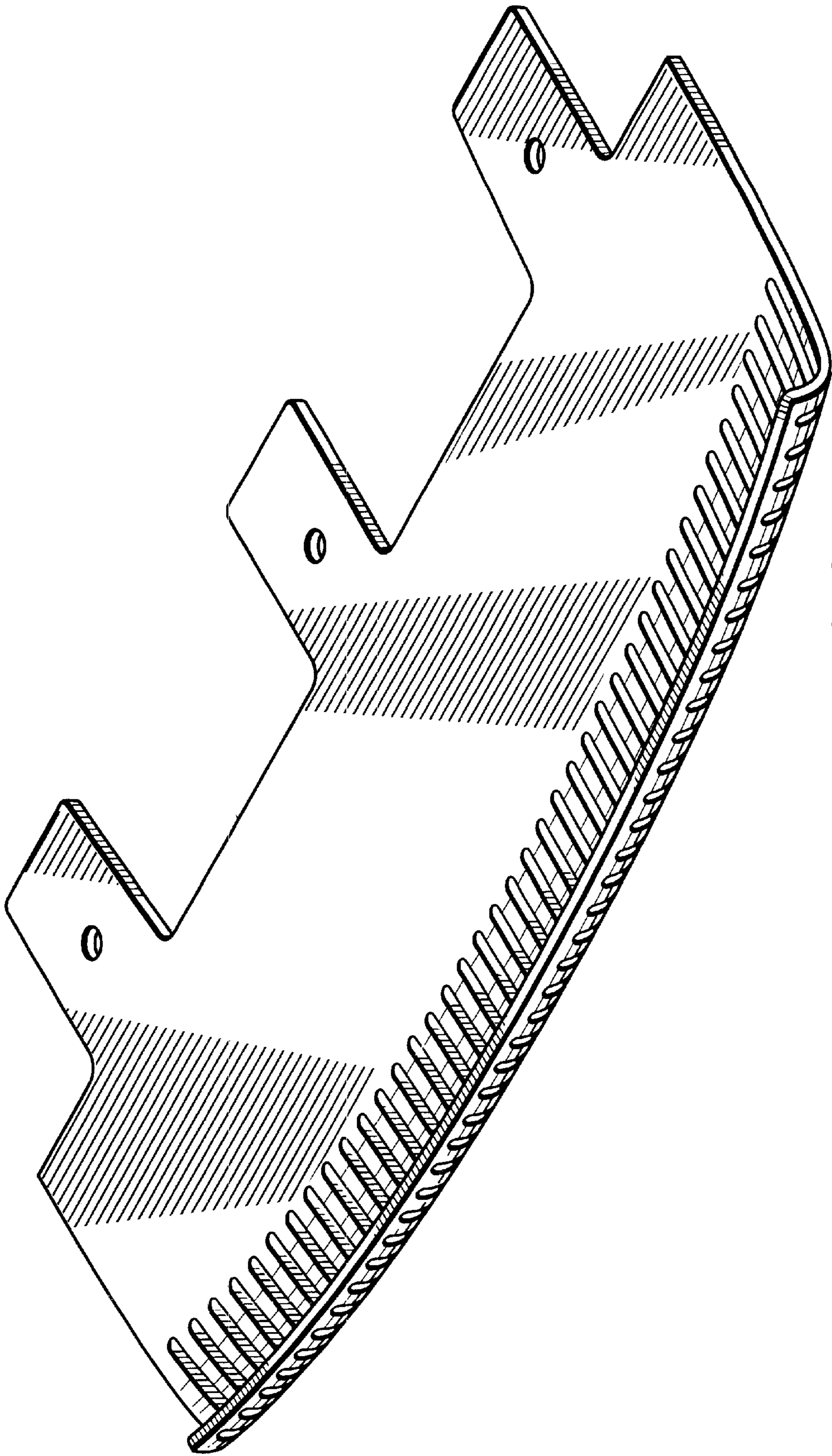

FIG. 1

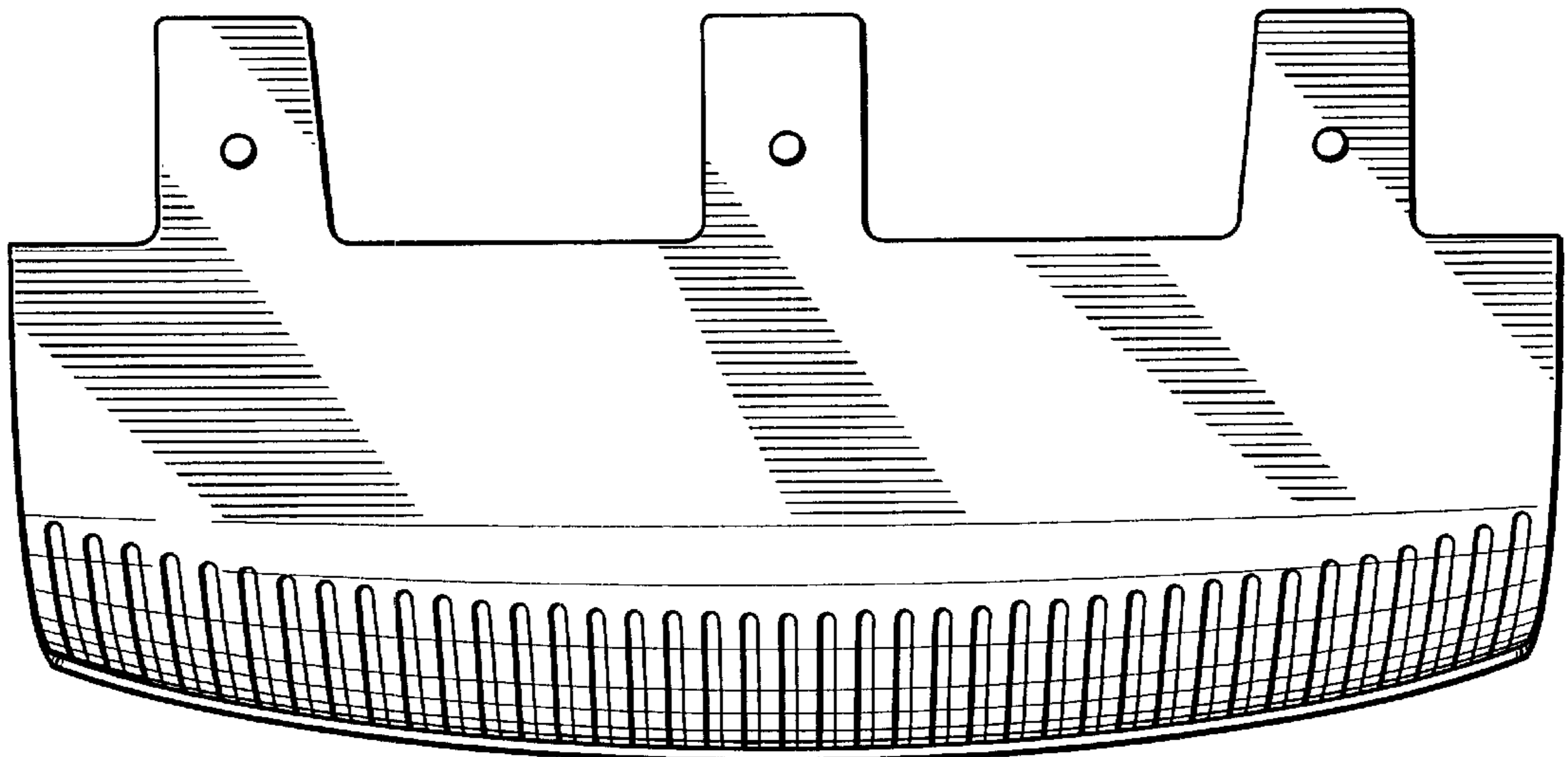

FIG. 2



FIG. 3



FIG. 4



FIG. 5

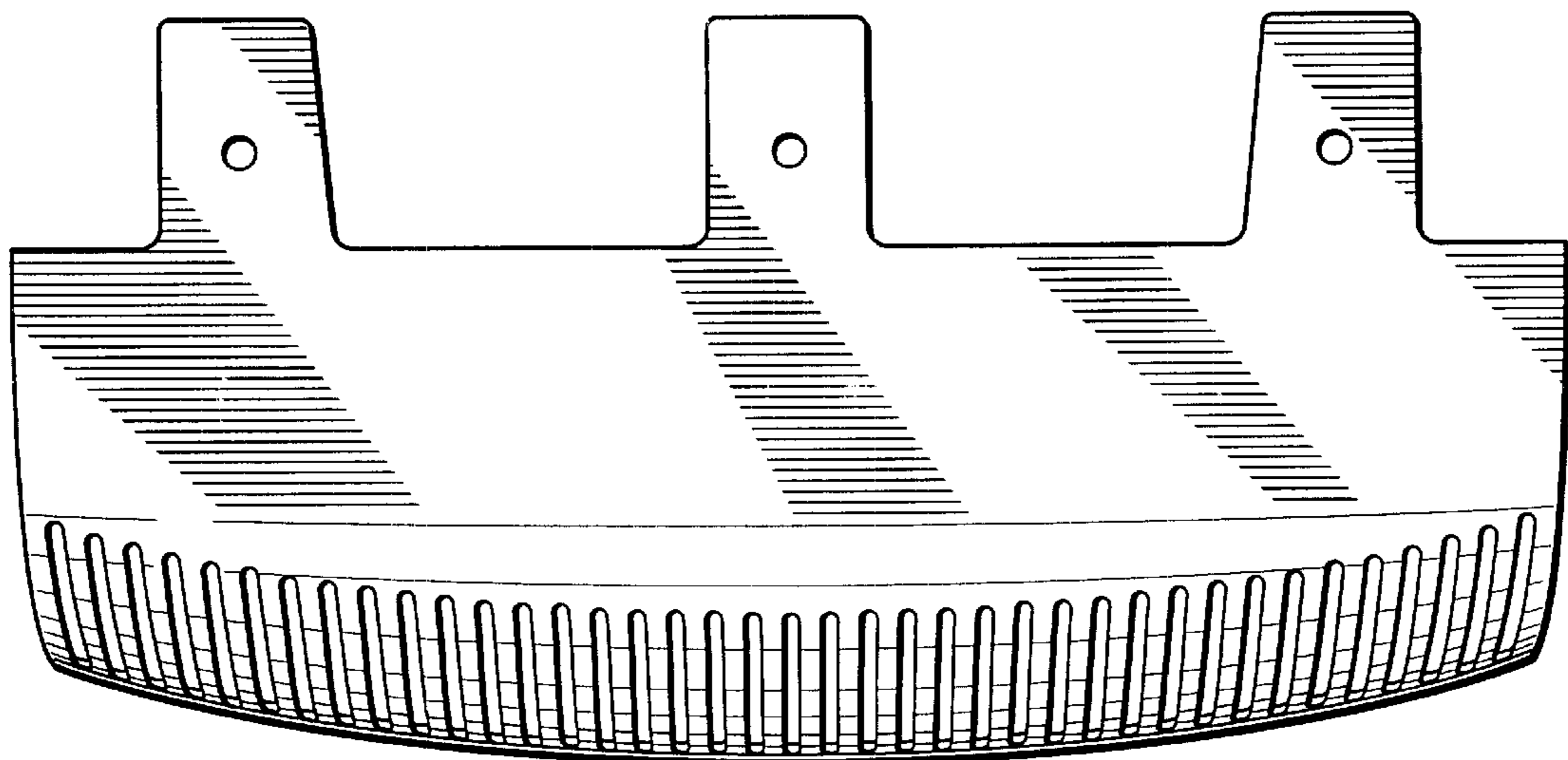

FIG. 6

UNITED STATES PATENT AND TRADEMARK OFFICE
CERTIFICATE OF CORRECTION

PATENT NO. : Des. 487,041 S
DATED : February 24, 2004
INVENTOR(S) : Schlacher

Page 1 of 1

It is certified that error appears in the above-identified patent and that said Letters Patent is hereby corrected as shown below:

Title page,

Item [56], **References Cited**, OTHER PUBLICATIONS, "Keith Seume, et al.,"
reference, substitute -- Porsche -- for "Porshe"

Signed and Sealed this

Twenty-second Day of June, 2004

A handwritten signature in black ink that reads "Jon W. Dudas". The signature is written in a cursive style with a large, looped initial "J".

JON W. DUDAS
Acting Director of the United States Patent and Trademark Office

UNITED STATES PATENT AND TRADEMARK OFFICE
CERTIFICATE OF CORRECTION

PATENT NO. : Des. 487,041 S
DATED : February 24, 2004
INVENTOR(S) : Schlatcher

Page 1 of 1

It is certified that error appears in the above-identified patent and that said Letters Patent is hereby corrected as shown below:

Title page,
Item [75], Inventors, "**Schlacher**" should read -- **Schlachter** --.

Signed and Sealed this

Twenty-first Day of September, 2004

A handwritten signature in black ink that reads "Jon W. Dudas". The signature is written in a cursive style with a large, looped initial "J".

JON W. DUDAS
Director of the United States Patent and Trademark Office