



US00D487013S

(12) **United States Design Patent**  
**Jenks**

(10) **Patent No.:** **US D487,013 S**

(45) **Date of Patent:** **\*\* Feb. 24, 2004**

(54) **HASP LOCKING APPARATUS**

5,836,626 A \* 11/1998 Coy ..... 292/289 X  
5,946,952 A \* 9/1999 Mintchenko ..... 70/2

(76) Inventor: **Bruce Jenks**, 772 Newton Way, Costa Mesa, CA (US) 92627

\* cited by examiner

(\*\*) Term: **14 Years**

*Primary Examiner*—Brian N. Vinson  
(74) *Attorney, Agent, or Firm*—Walter A. Hackler

(21) Appl. No.: **29/159,266**

(57) **CLAIM**

(22) Filed: **Apr. 17, 2002**

The ornamental design for the hasp locking apparatus, shown and described.

(51) **LOC (7) Cl.** ..... **08-07**

(52) **U.S. Cl.** ..... **D8/343**

(58) **Field of Search** ..... D8/330, 331, 343,  
D8/345; 70/54, 55, 56, 2-13, 31-34, 416-417;  
292/262, 288-298

**DESCRIPTION**

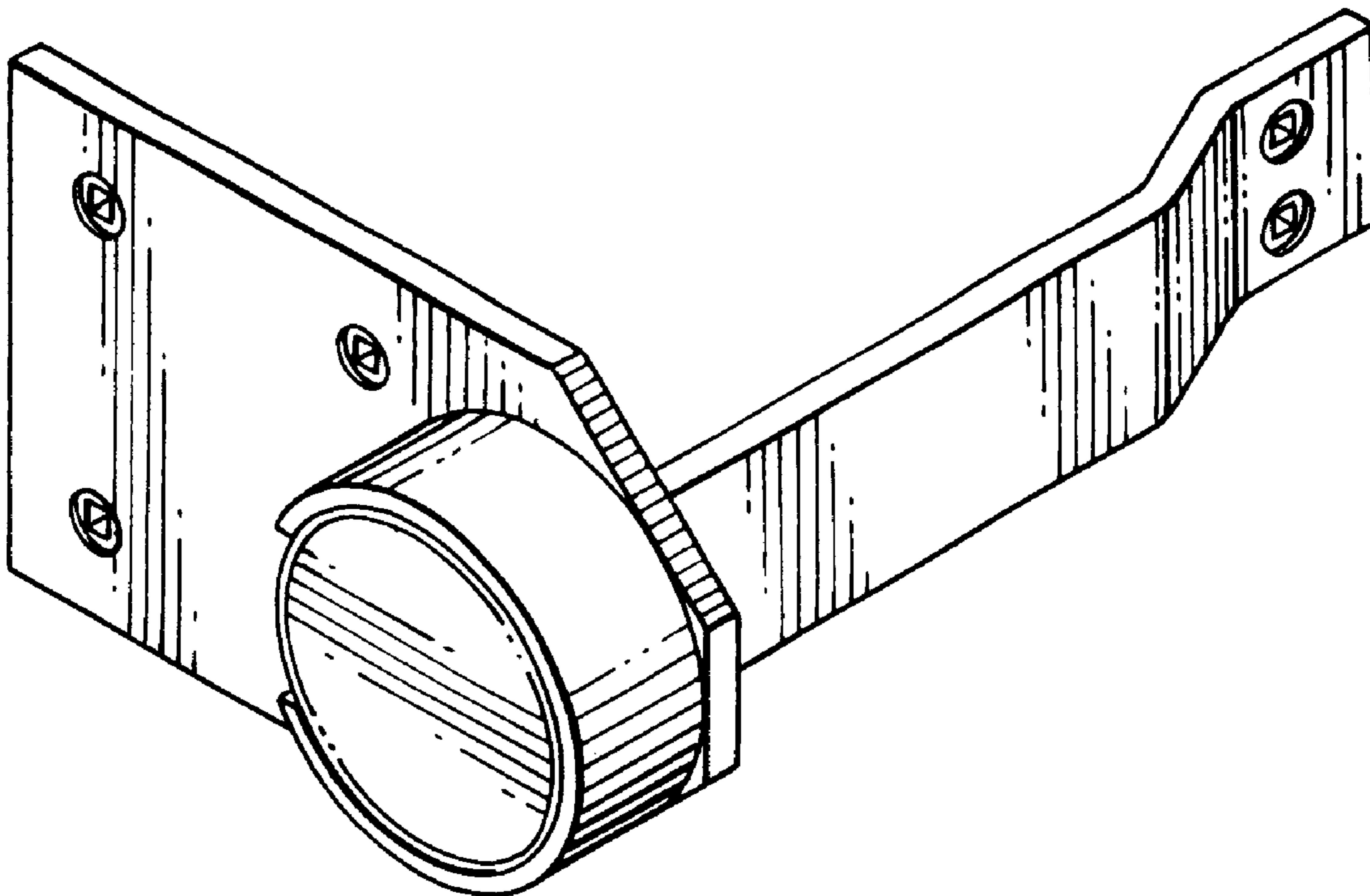
(56) **References Cited**

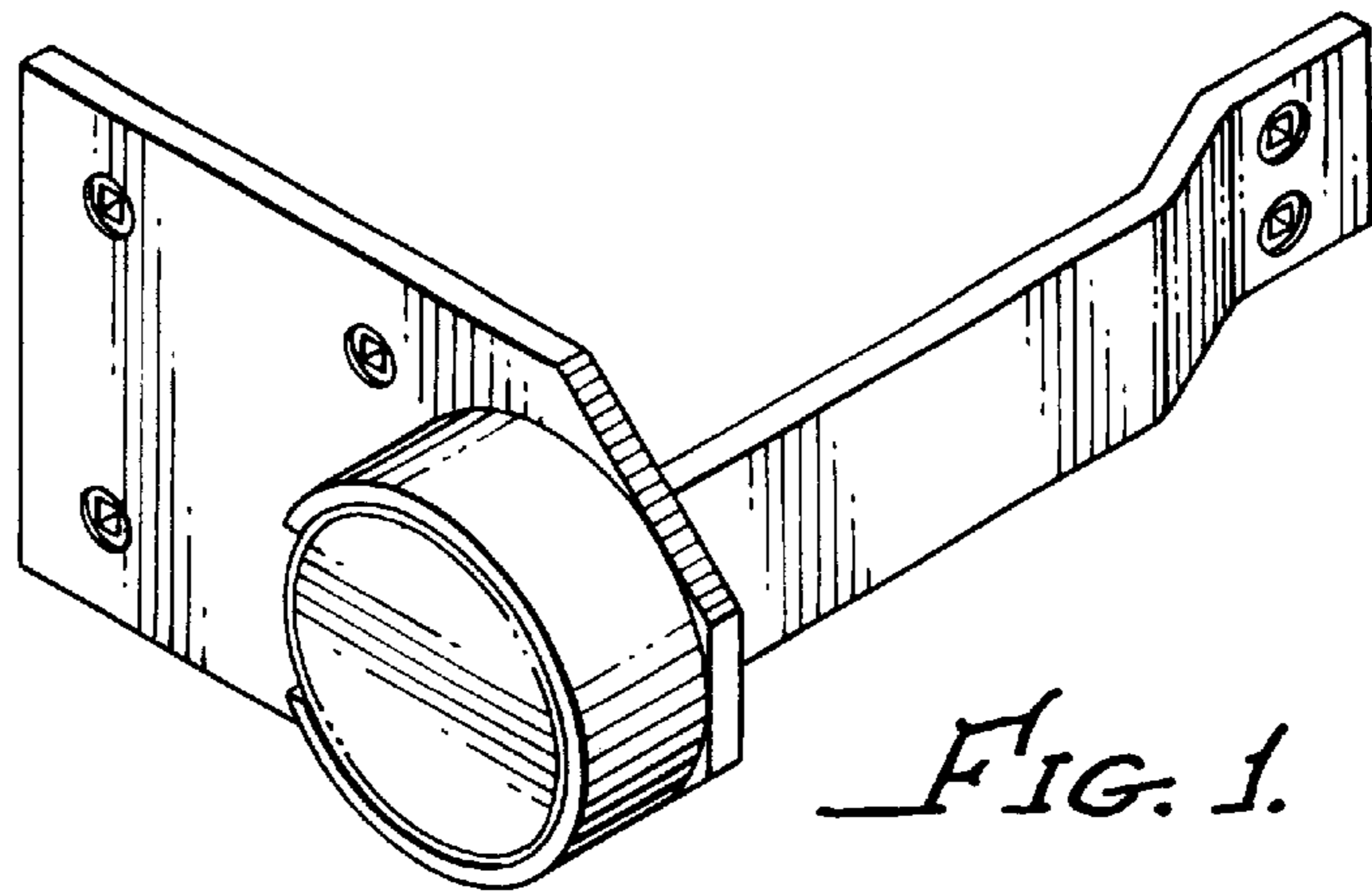
**U.S. PATENT DOCUMENTS**

3,914,965 A \* 10/1975 Paxton ..... 292/288 X  
D269,063 S \* 5/1983 Gill ..... D8/343  
4,770,451 A \* 9/1988 Souza ..... 292/289  
5,172,574 A \* 12/1992 Perfetto ..... 70/56

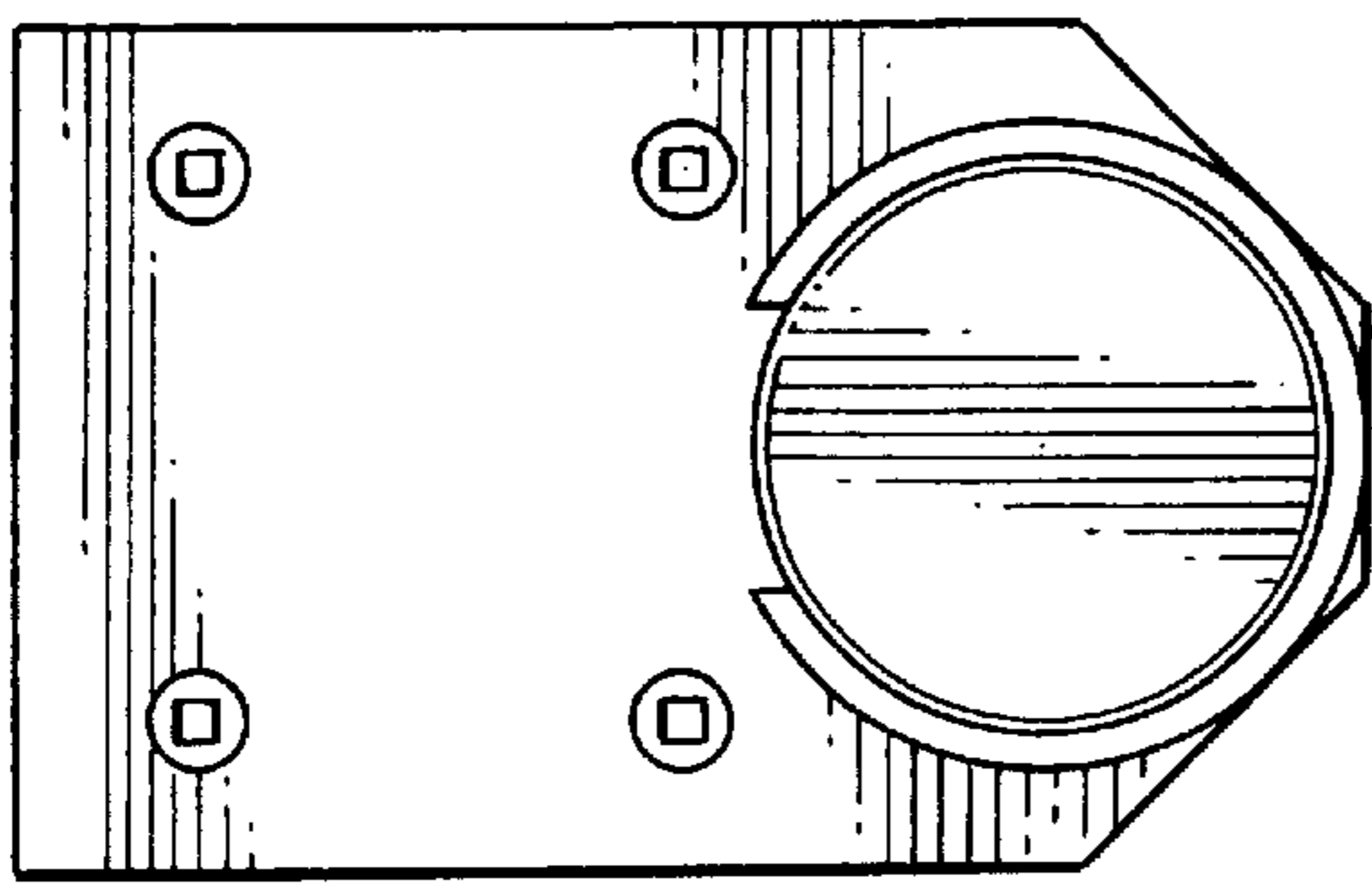
FIG. 1 is an isometric view of the present invention directed at a top left corner of the present invention;  
FIG. 2 is a front elevational view of the present invention;  
FIG. 3 is a bottom elevational view of the present invention;  
FIG. 4 is a left side elevational view of the present invention;  
FIG. 5 is a right side elevational view of the present invention; and,  
FIG. 6 is a rear view of the present invention.

**1 Claim, 2 Drawing Sheets**

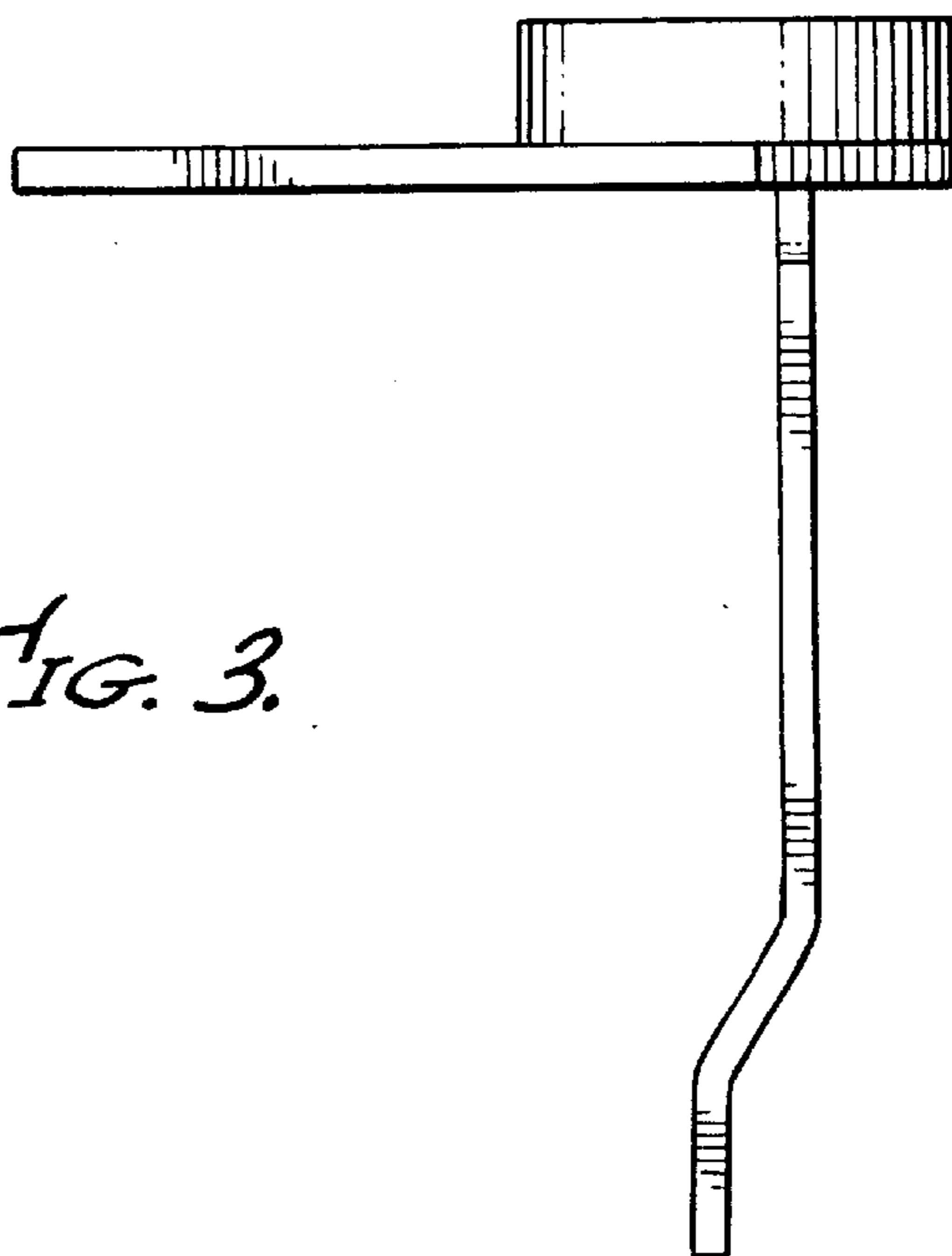




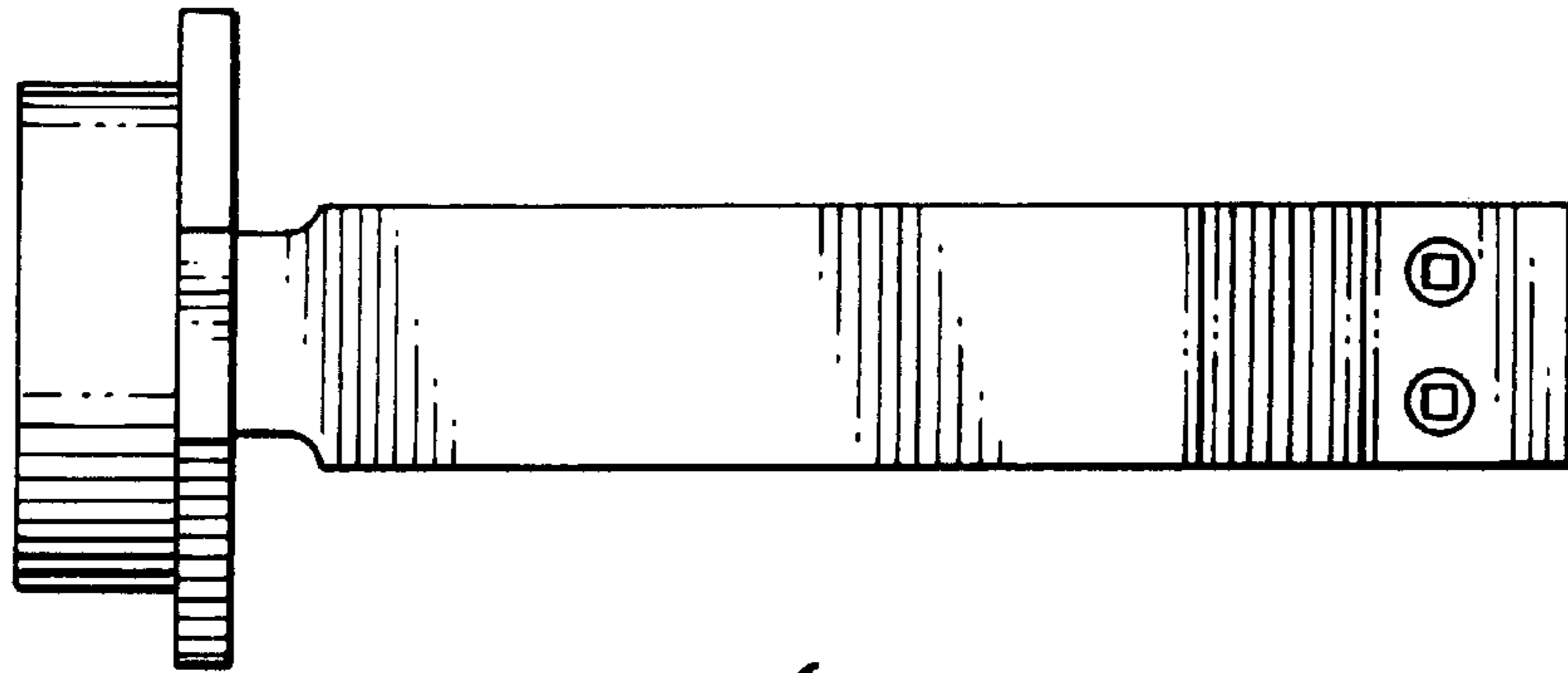
*FIG. 1.*



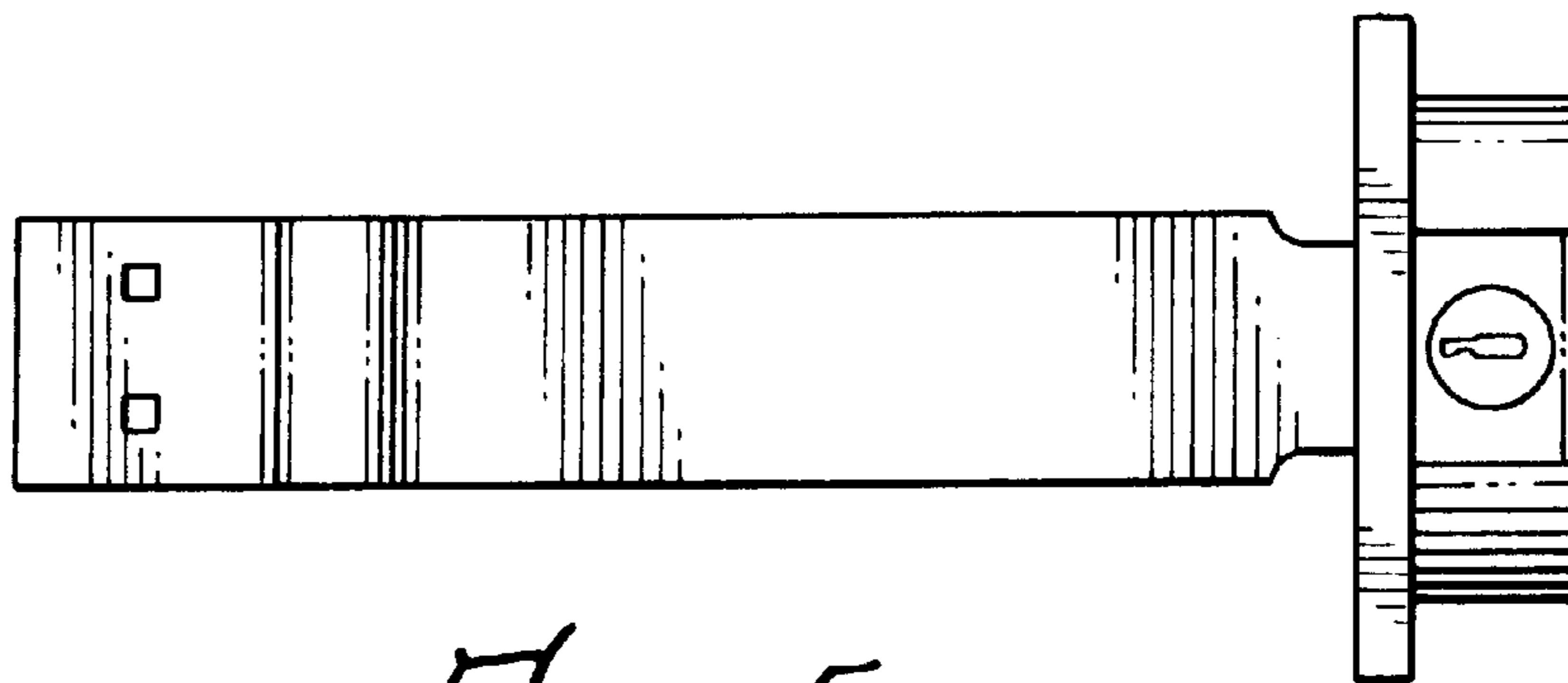
*FIG. 2.*



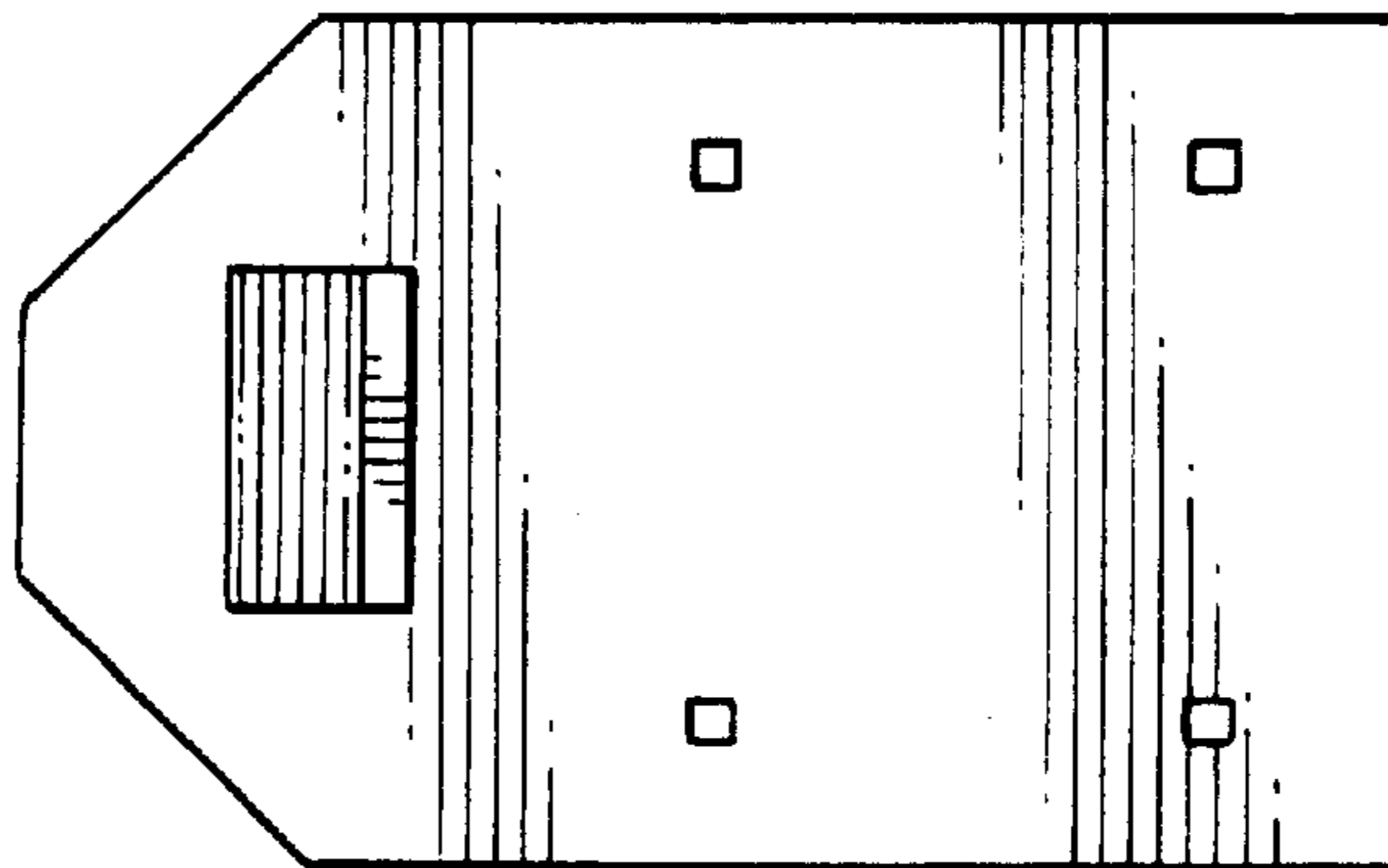
*FIG. 3.*



*FIG. 4.*



*FIG. 5.*



*FIG. 6.*