



US00D486761S

(12) **United States Design Patent**  
**Meyers**

(10) **Patent No.:** **US D486,761 S**

(45) **Date of Patent:** **\*\* Feb. 17, 2004**

(54) **ORNAMENTAL HOUSING**

(75) Inventor: **David Meyers**, Kaysville, UT (US)

(73) Assignee: **SBS Enterprises, LLC**, Alpine, UT (US)

(\*\*) Term: **14 Years**

6,302,230	B1	10/2001	Kamen et al.
6,311,998	B1	11/2001	Wang et al.
6,343,667	B2	2/2002	Sauve
6,345,678	B1	2/2002	Chang
6,347,681	B1	2/2002	Patmont et al.
2001/0035308	A1	11/2001	Sauve
2002/0000339	A1	1/2002	Tsai
2002/0079855	A1	6/2002	Parks

**OTHER PUBLICATIONS**

Declaration of John T. Paskett Regarding Non-Documentary Potential Prior Art.  
www.soosung.comForklift products, pp. 1-4, Jan. 23, 2002.  
www.1-christmas-presents.com/xing.htmlXing Motor Drive, p. 1, Jan. 21, 2002.

\* cited by examiner

*Primary Examiner*—Alan P. Douglas  
*Assistant Examiner*—Linda Brooks

(74) *Attorney, Agent, or Firm*—Clayton, Howarth & Cannon, P.C.

(21) Appl. No.: **29/157,515**

(22) Filed: **Mar. 19, 2002**

(51) **LOC (7) Cl.** ..... **12-11**

(52) **U.S. Cl.** ..... **D12/126**

(58) **Field of Search** ..... D12/107, 110,  
D12/111, 114, 122, 400, 126; D21/423,  
765; 180/11, 65.1, 181, 218-224, 228,  
342; 280/87.042, 287, 296

(56) **References Cited**

**U.S. PATENT DOCUMENTS**

3,903,980	A	9/1975	Darras	
4,014,402	A	3/1977	Muto	
4,821,832	A	4/1989	Patmont	
5,020,621	A	6/1991	Martin	
5,127,488	A	7/1992	Shanahan	
5,491,390	A	2/1996	McGreen	
5,494,128	A	2/1996	Witthaus	
5,495,904	A	3/1996	Zwaan et al.	
5,660,242	A	8/1997	Witthaus	
5,775,452	A	7/1998	Patmont	
5,927,420	A	7/1999	Karrington	
5,950,754	A	9/1999	Ondrish, Jr.	
5,975,229	A	11/1999	Hosoda	
6,012,539	A	1/2000	Patmont	
6,062,328	A	5/2000	Campbell et al.	
6,095,274	A	8/2000	Patmont	
D438,825	S *	3/2001	Tsuboi et al.	D12/114
6,227,324	B1	5/2001	Sauve	
6,273,205	B1	8/2001	Tsai	

(57) **CLAIM**

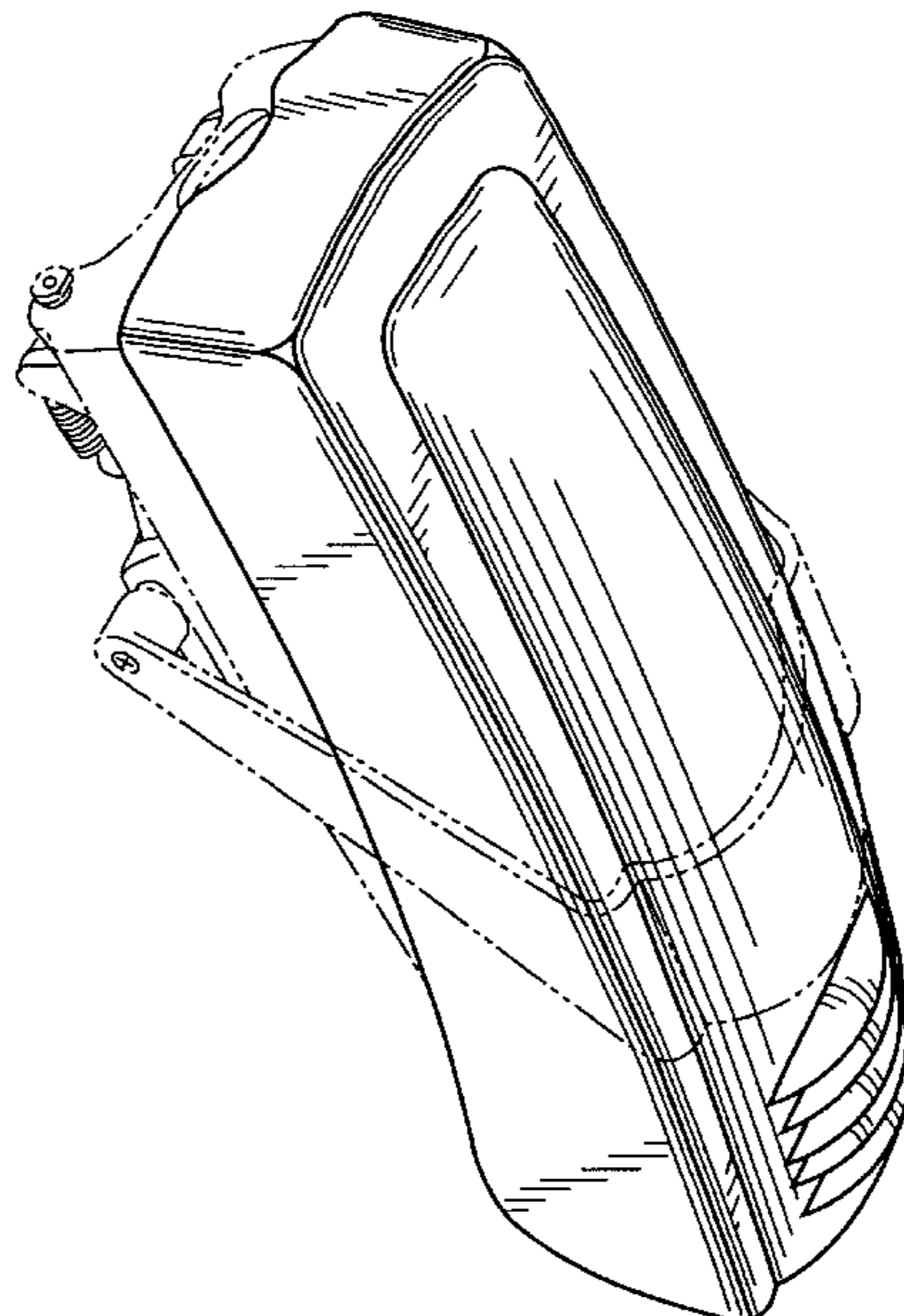
I claim the ornamental design for an ornamental housing, as shown and described.

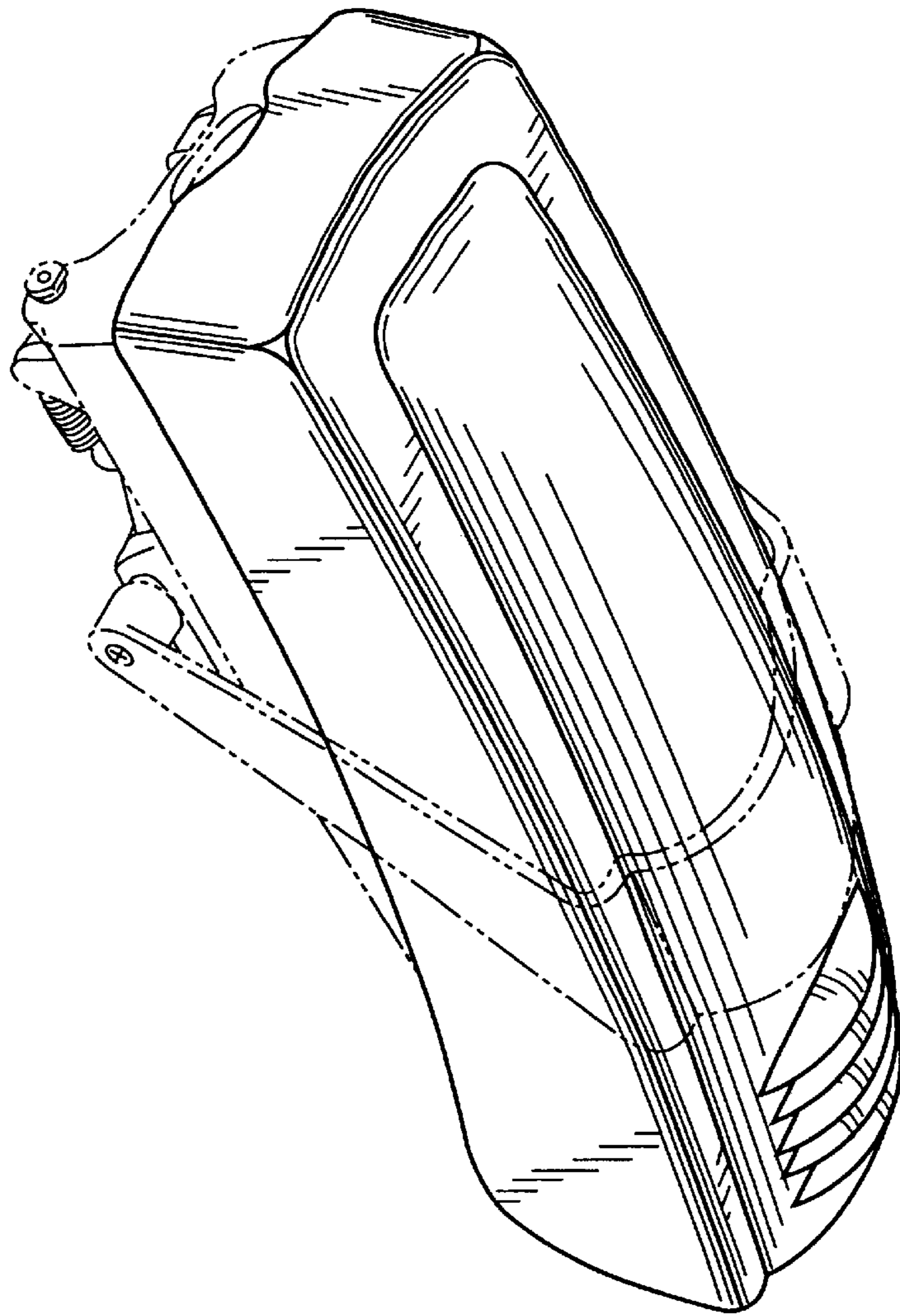
**DESCRIPTION**

FIG. 1 is a perspective view thereof;  
FIG. 2 is a top view thereof;  
FIG. 3 is a bottom view thereof;  
FIG. 4 is a right side view thereof;  
FIG. 5 is a left side view thereof;  
FIG. 6 is a front view thereof; and,  
FIG. 7 is a rear view thereof.

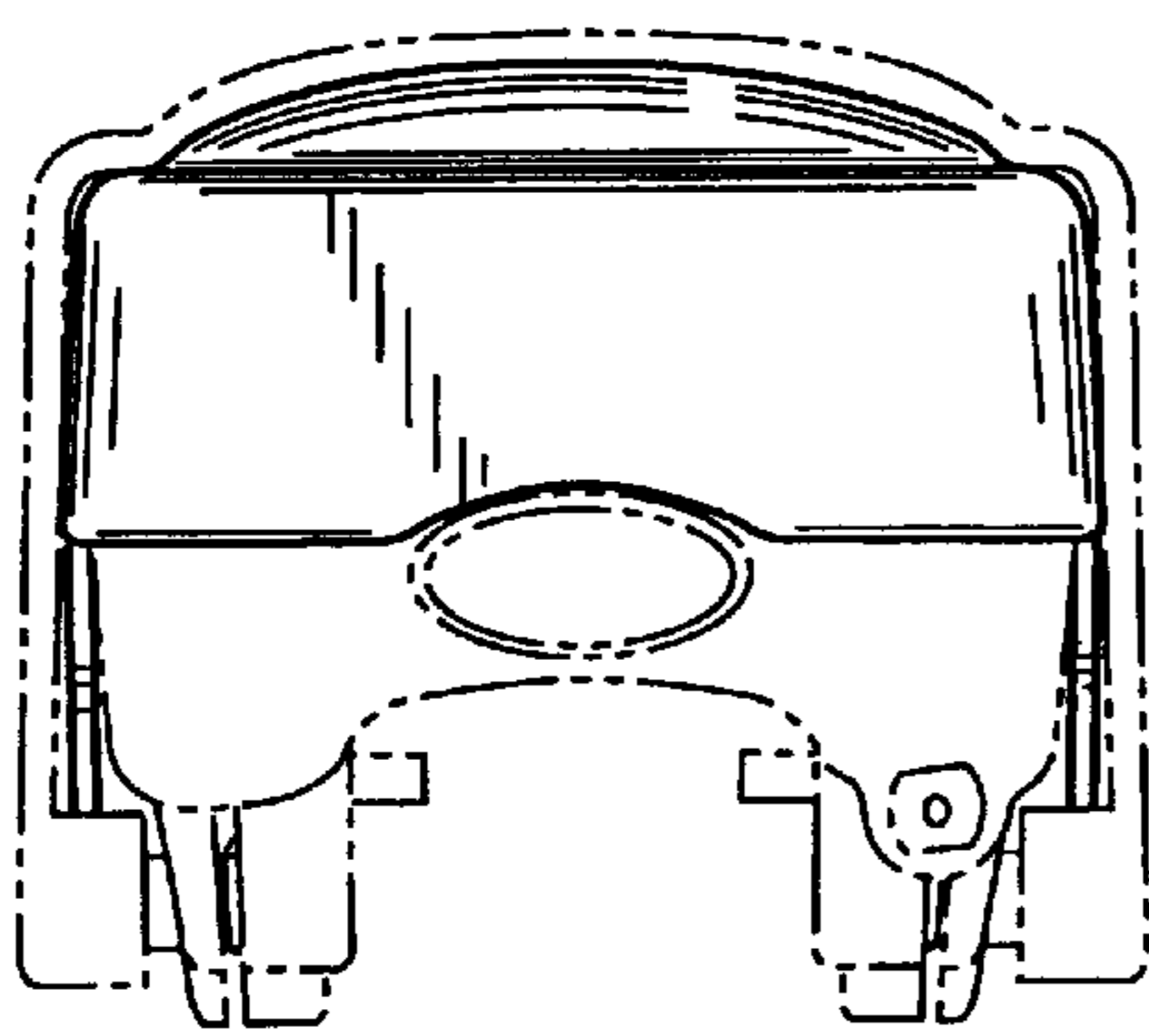
The portions of the figures shown in broken lines are for illustrative purposes only and form no part of the claimed design.

**1 Claim, 3 Drawing Sheets**

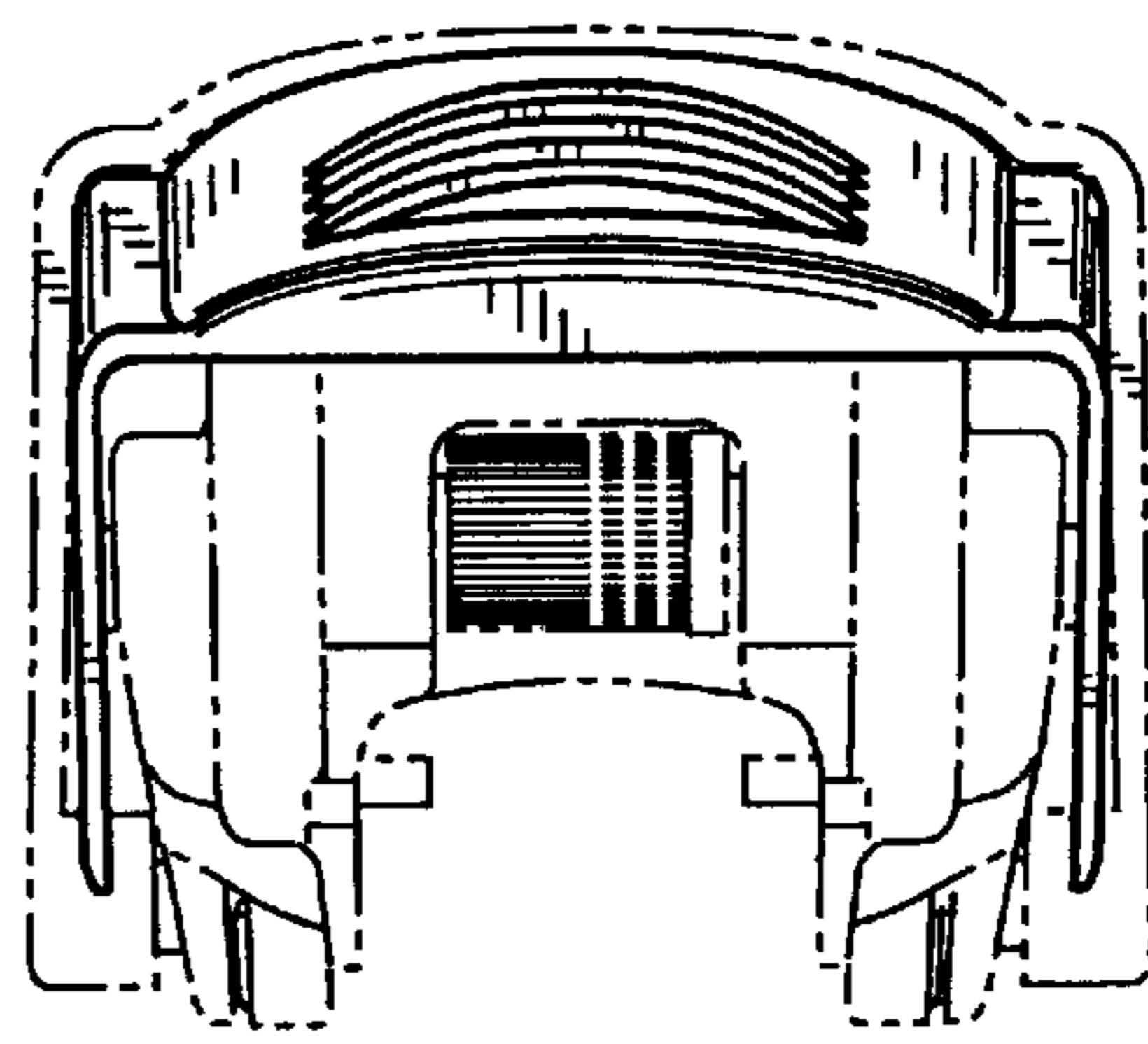




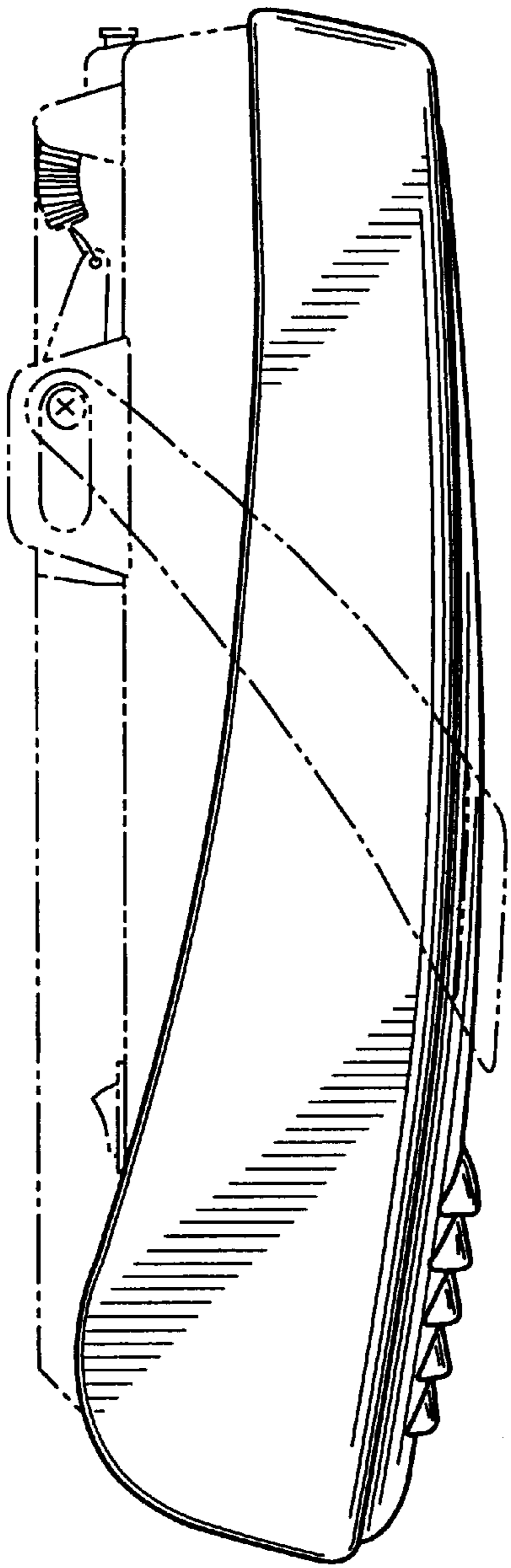
**Fig. 1**



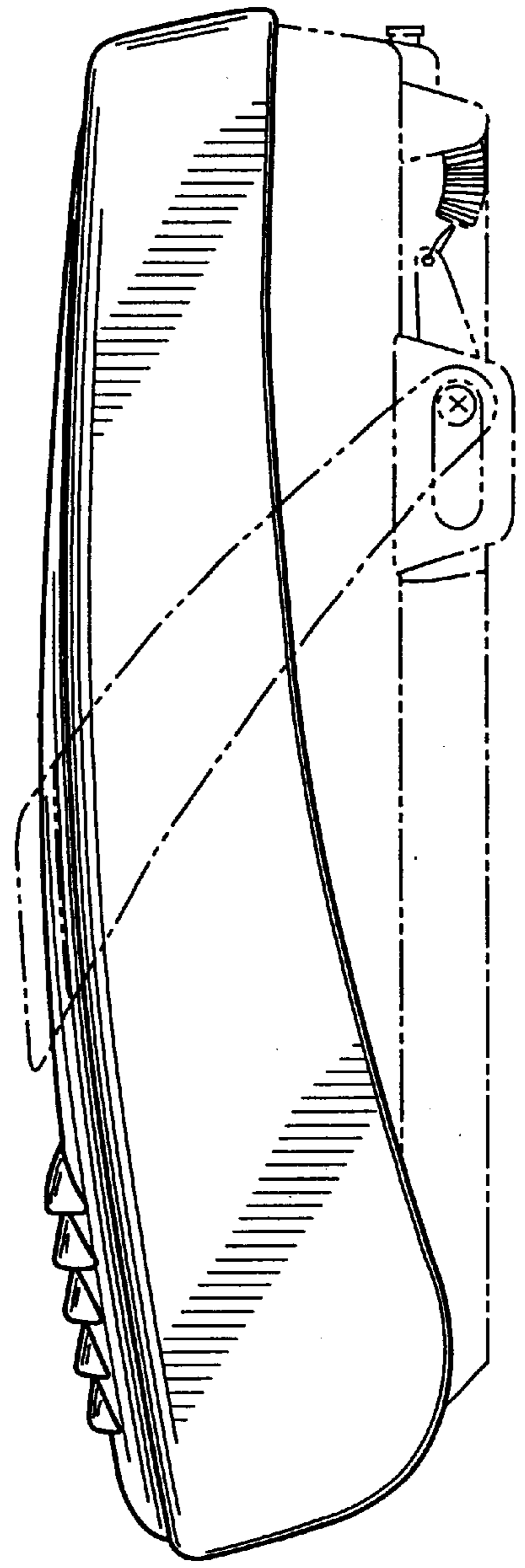
**Fig. 2**



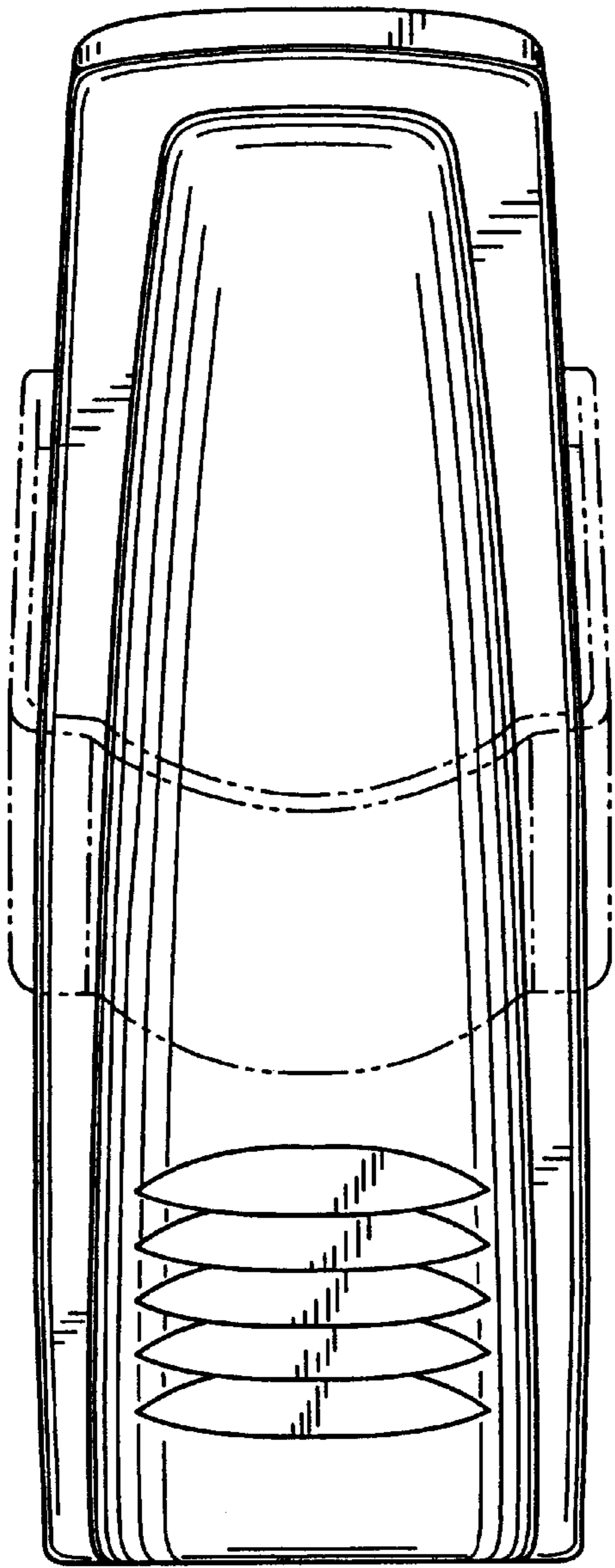
**Fig. 3**



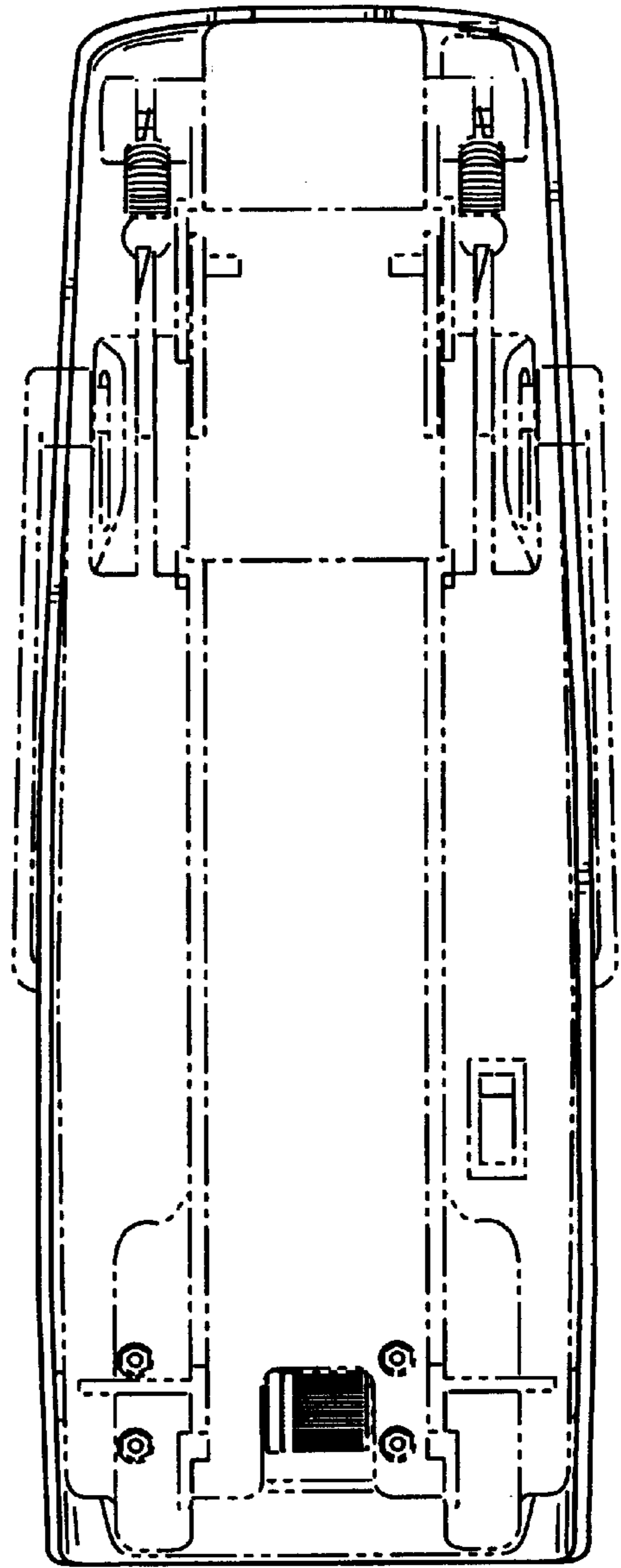
**Fig. 4**



**Fig. 5**



**Fig. 6**



**Fig. 7**