



US00D486759S

(12) **United States Design Patent**
Armstrong

(10) **Patent No.:** **US D486,759 S**

(45) **Date of Patent:** **** Feb. 17, 2004**

(54) **TAKE-OFF TRAILER BODY**

(76) Inventor: **Lonnie D. Armstrong**, 20500 State Hwy. 28, Glenwood, Pope, MN (US) 56334

(**) Term: **14 Years**

(21) Appl. No.: **29/177,933**

(22) Filed: **Mar. 17, 2003**

(51) **LOC (7) Cl.** **12-10**

(52) **U.S. Cl.** **D12/102**

(58) **Field of Search** D12/101, 102; 280/475, 656, 763.1, 482; 296/190, 181

(56) **References Cited**

U.S. PATENT DOCUMENTS

D240,806 S	8/1976	Hawes	
D265,301 S	* 7/1982	Zander D12/102
4,387,835 A	6/1983	Golzer	
D313,955 S	* 1/1991	van der Merwe et al.	. D12/102
5,011,170 A	4/1991	Forbes et al.	
D373,100 S	8/1996	Carter	

D378,583 S * 3/1997 Aitken, III D12/102

5,855,309 A 1/1999 Hallsworth

D422,243 S * 4/2000 Keirstead D12/102

D443,561 S * 6/2001 Voogt D12/102

6,283,537 B1 9/2001 Devore, III

* cited by examiner

Primary Examiner—Melody N. Brown

(74) *Attorney, Agent, or Firm*—Albert W. Watkins

(57) **CLAIM**

The ornamental design for a take-off trailer body, as shown and described.

DESCRIPTION

FIG. 1 is a rear elevational view of a take-off trailer body showing my new design;

FIG. 2 is a front elevational view thereof;

FIG. 3 is a left side elevational view thereof;

FIG. 4 is a right side elevational view thereof; and,

FIG. 5 is a top plan view thereof.

The broken lines shown in the figures are for illustrative purpose only and form no part of the claimed design.

1 Claim, 5 Drawing Sheets

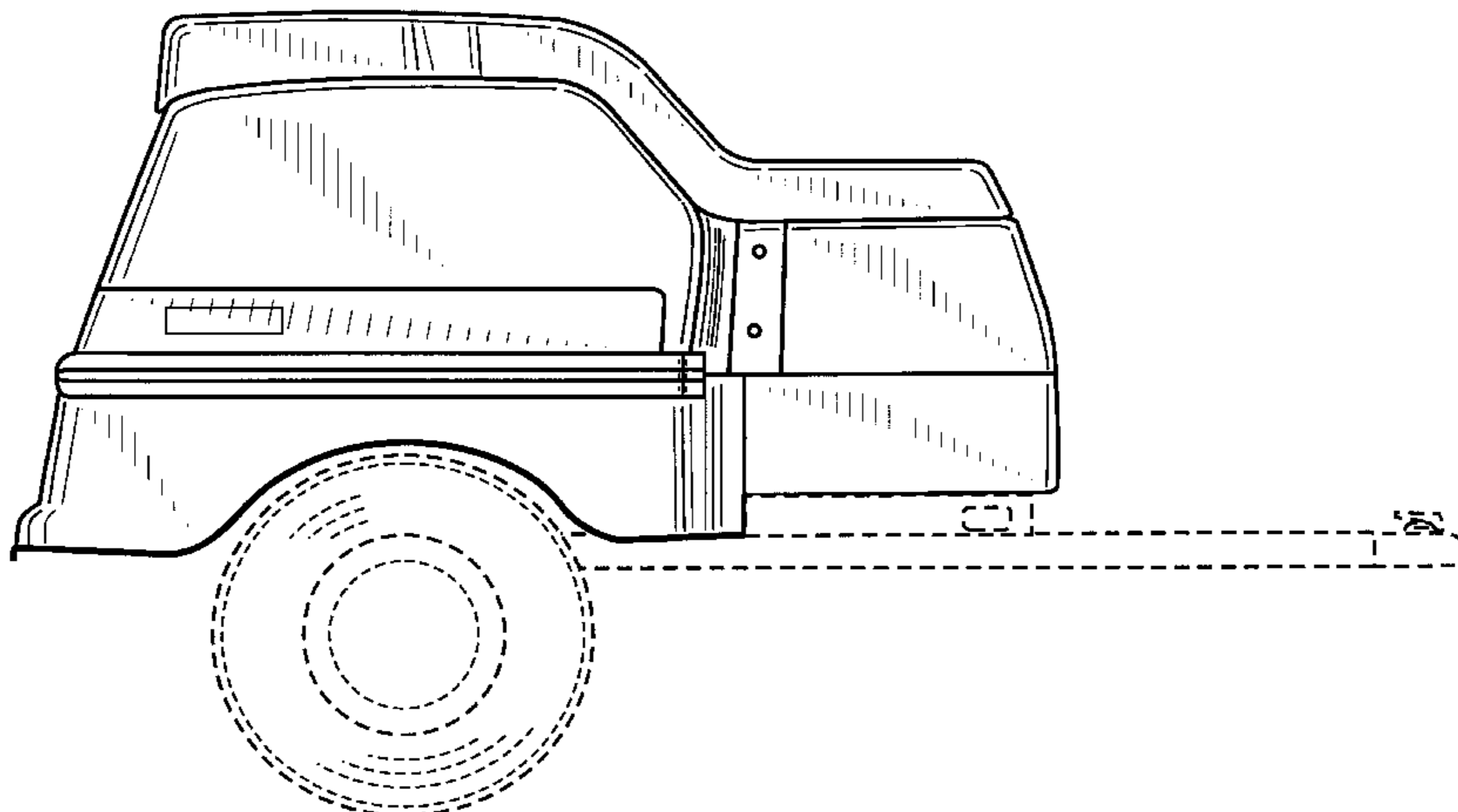
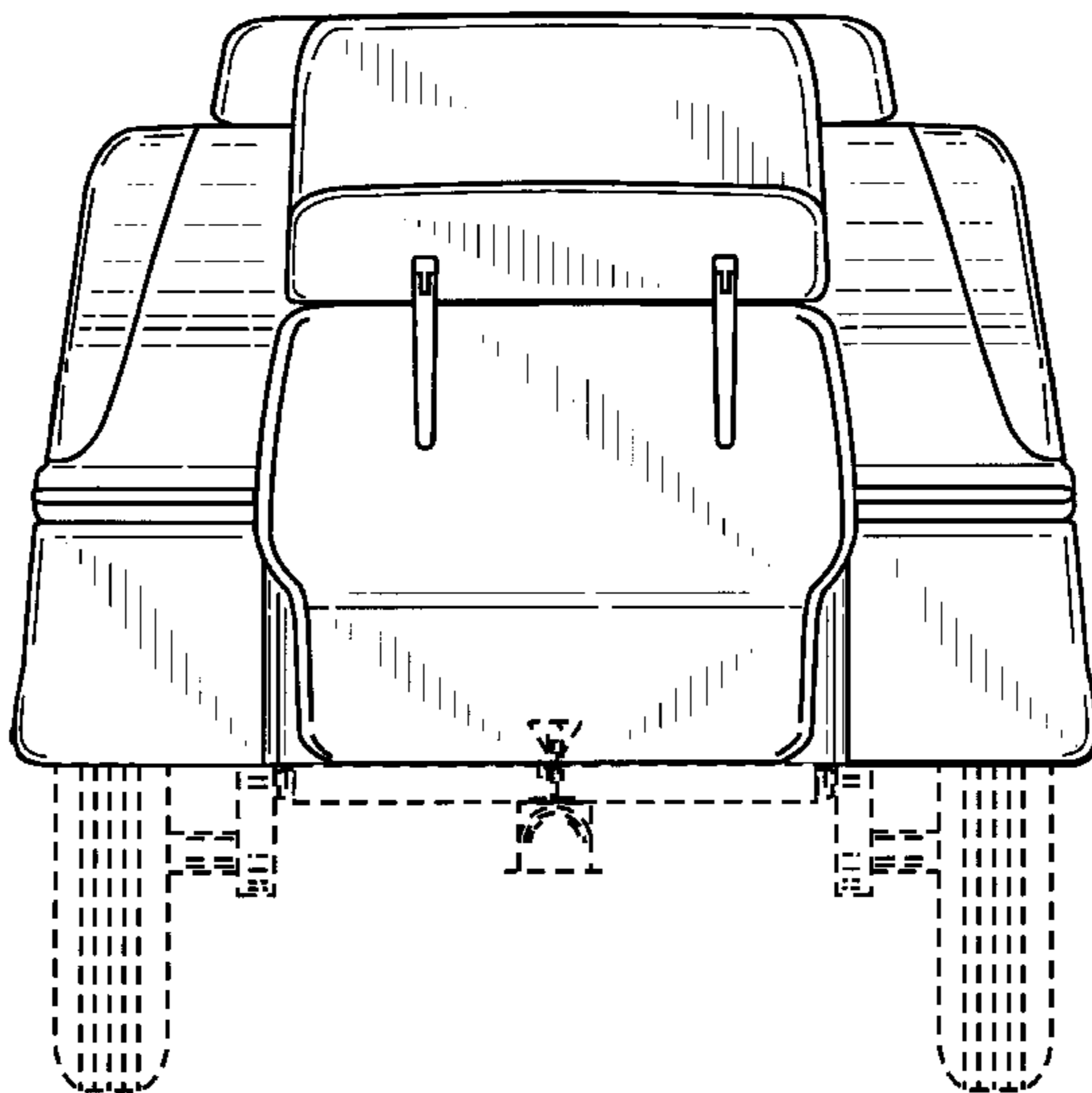

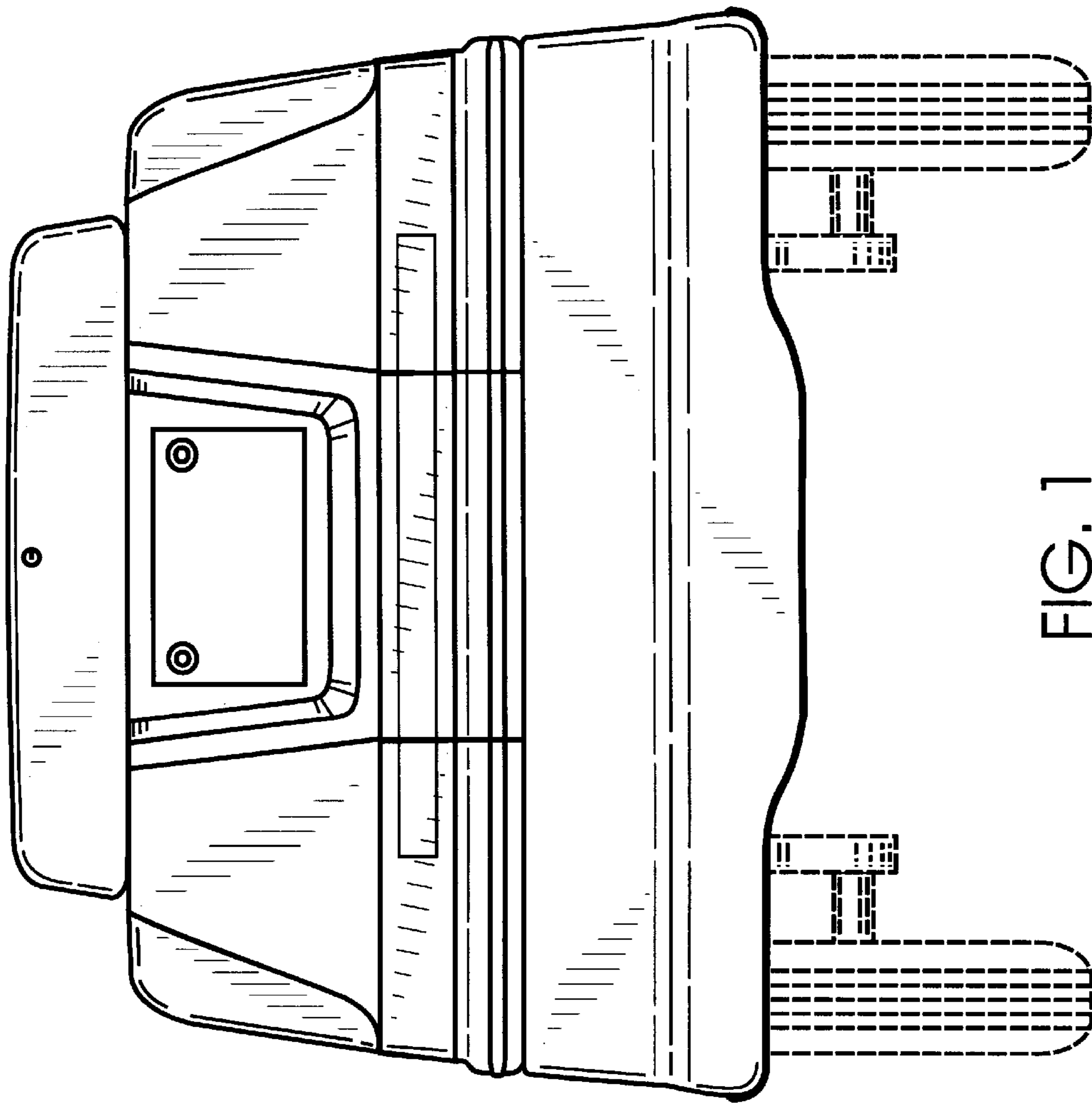

FIG. 1

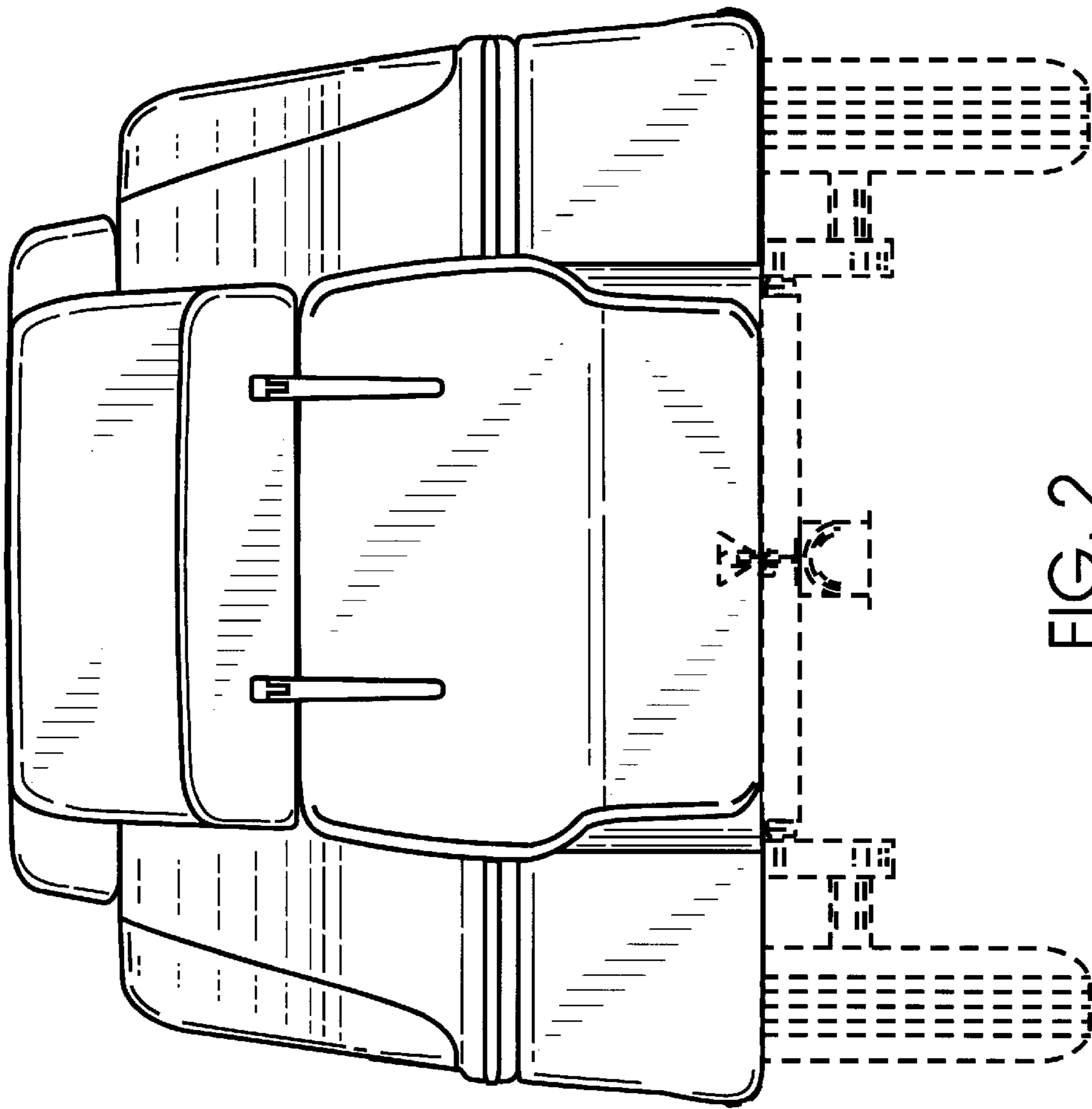

FIG. 2

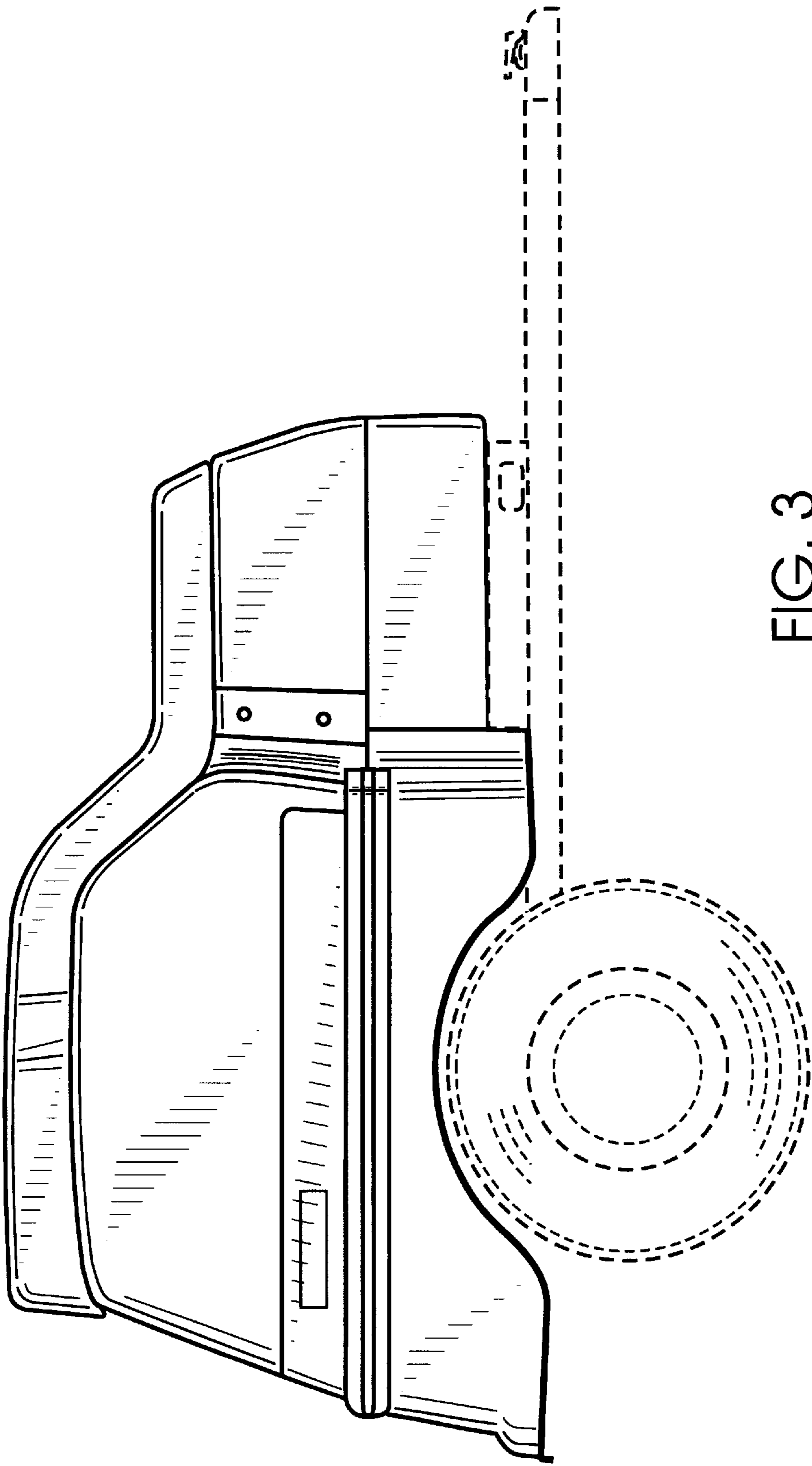

FIG. 3

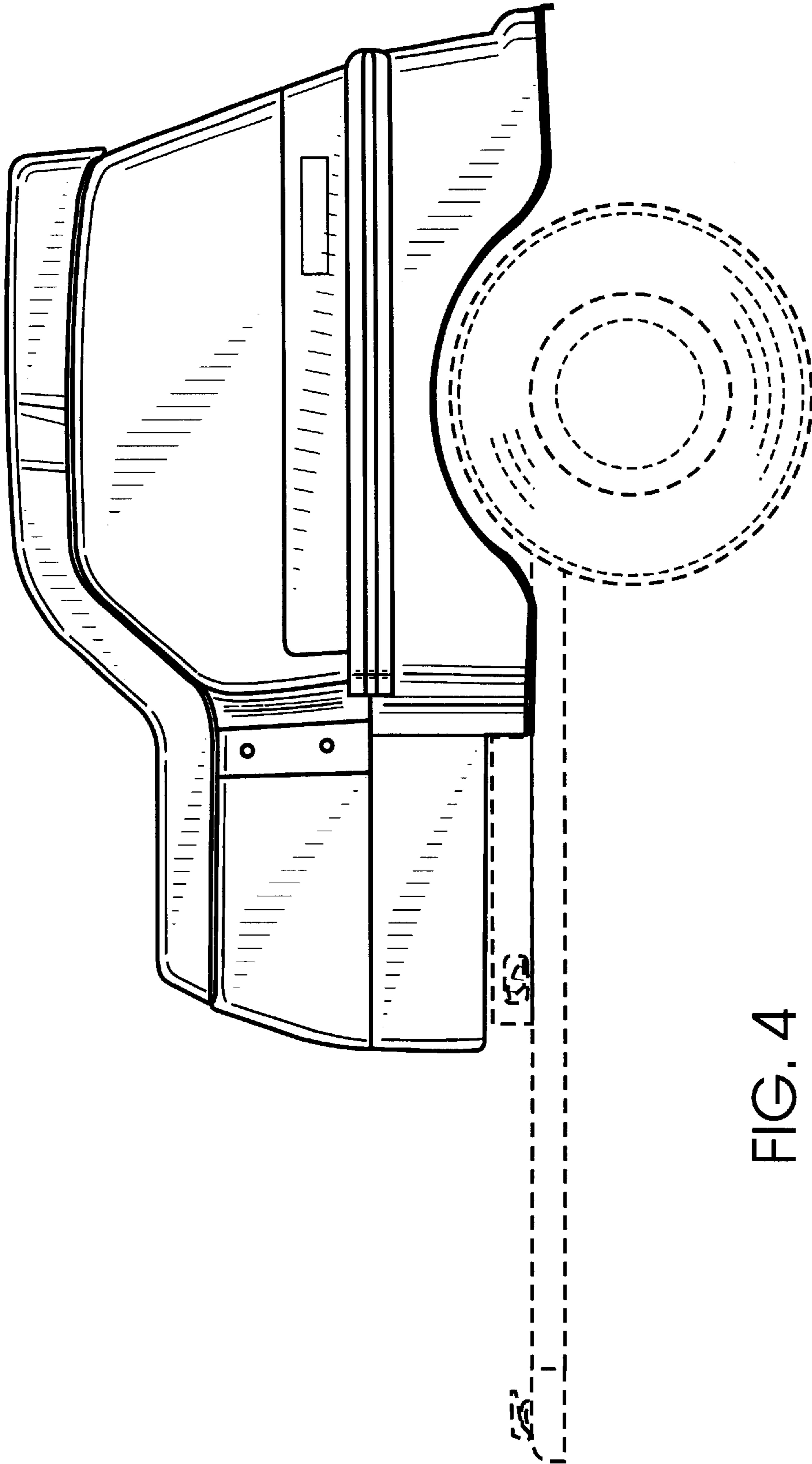

FIG. 4

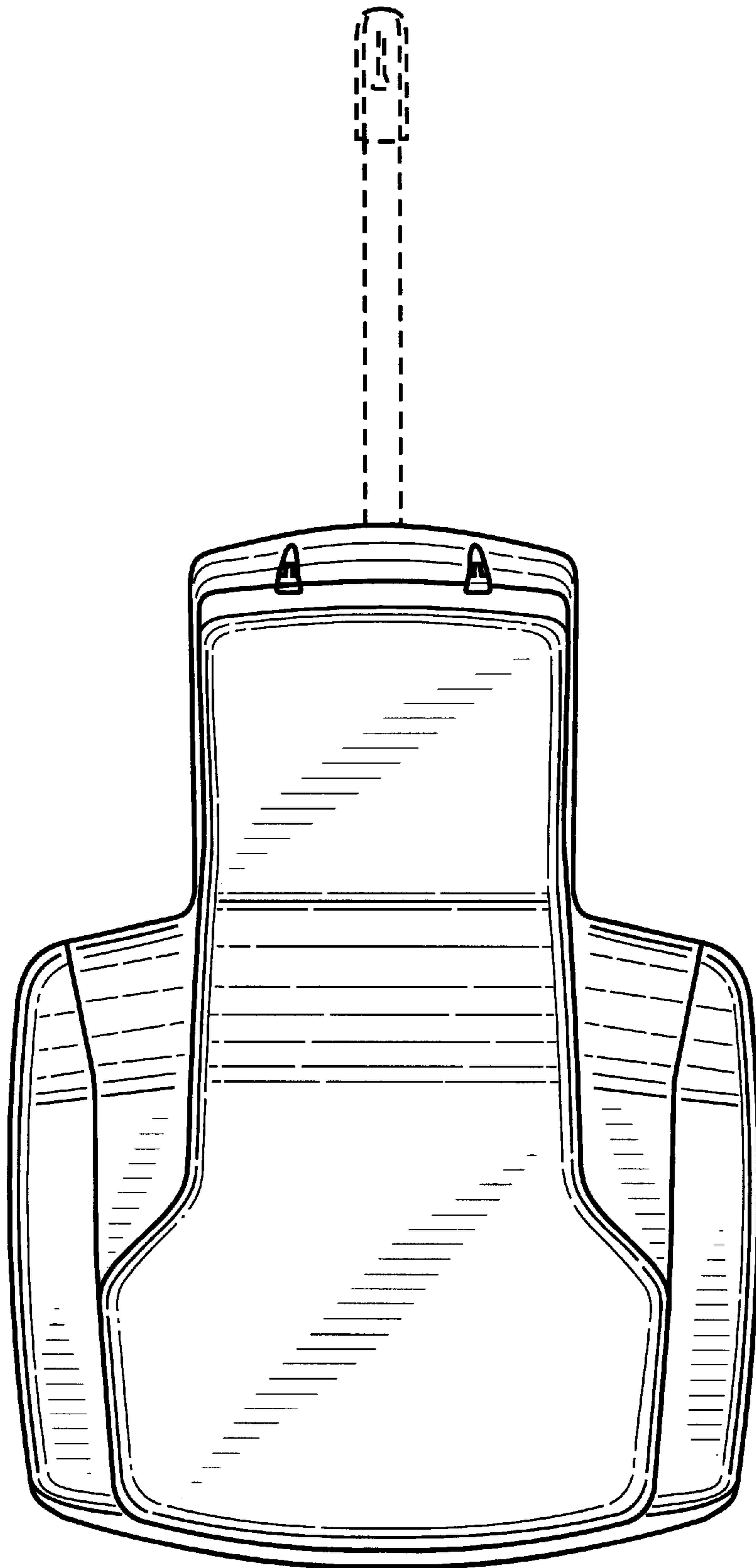

FIG. 5