



US00D486719S

(12) **United States Design Patent**
Erickson

(10) **Patent No.:** **US D486,719 S**

(45) **Date of Patent:** **** Feb. 17, 2004**

(54) **WATER MAIN VALVE LOCK**

(76) Inventor: **James E. Erickson**, 6612 Kristen Ct.,
Orlando, FL (US) 32818

(**) Term: **14 Years**

(21) Appl. No.: **29/179,644**

(22) Filed: **Apr. 14, 2003**

Related U.S. Application Data

(63) Continuation-in-part of application No. 09/918,201, filed on
Jul. 31, 2001, now abandoned.

(51) **LOC (7) Cl.** **08-07**

(52) **U.S. Cl.** **D8/330**

(58) **Field of Search** D8/330, 331, 343;
70/242-244, 175-179, 266, 232, 275, 203,
443, 444, DIG. 57; 137/384.2, 384.4, 384.6,
385; 184/86

(56) **References Cited**

U.S. PATENT DOCUMENTS

882,106	A	*	10/1906	Werner	70/179
1,294,669	A	*	2/1919	Jensen	70/275
1,534,965	A	*	4/1925	Keeler	70/176
3,524,334	A	*	8/1970	Salvesen	70/275

D272,515	S	*	2/1984	Wilson	D8/330
4,538,434	A	*	9/1985	Janzen, Sr. et al.	70/179
4,658,608	A	*	4/1987	Fox	70/179
D298,911	S	*	12/1988	Burke, Sr.	D8/330
5,598,724	A	*	2/1997	Primeau	137/385
5,823,023	A	*	10/1998	Benda	70/175
6,152,161	A	*	11/2000	Yokota et al.	70/178
D439,498	S	*	3/2001	Hennig	D8/331
6,604,391	B2	*	8/2003	Vellette et al.	70/179

* cited by examiner

Primary Examiner—Prabhakar Deshmukh

(74) *Attorney, Agent, or Firm*—William M. Hobby, III

(57) **CLAIM**

The ornamental design for a water main valve lock, as
shown and described.

DESCRIPTION

FIG. 1 is a top, right side perspective view of my new water
main lock valve;
FIG. 2 is a front elevation;
FIG. 3 is a rear elevation;
FIG. 4 is a left side elevation;
FIG. 5 is a top plan view; and,
FIG. 6 is a bottom plan view.

1 Claim, 2 Drawing Sheets

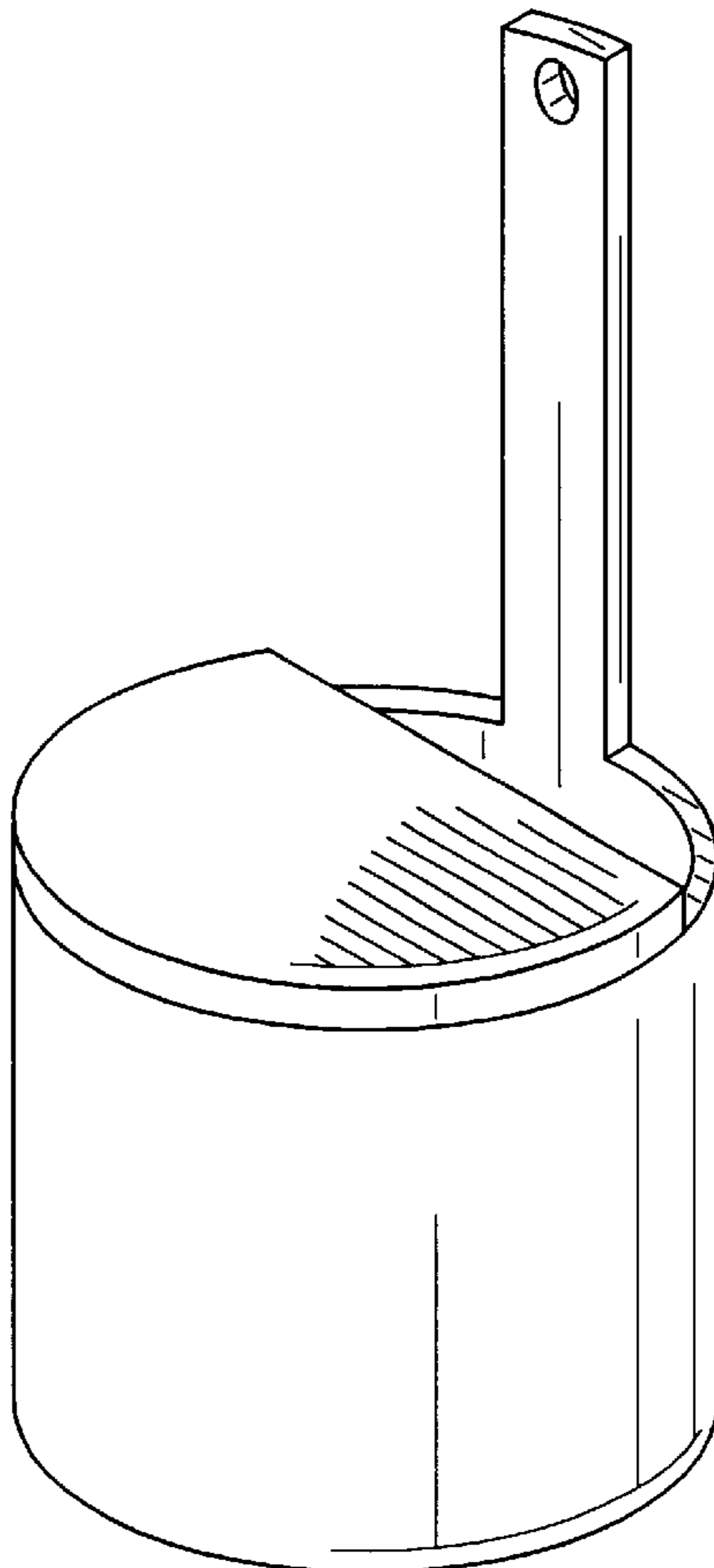

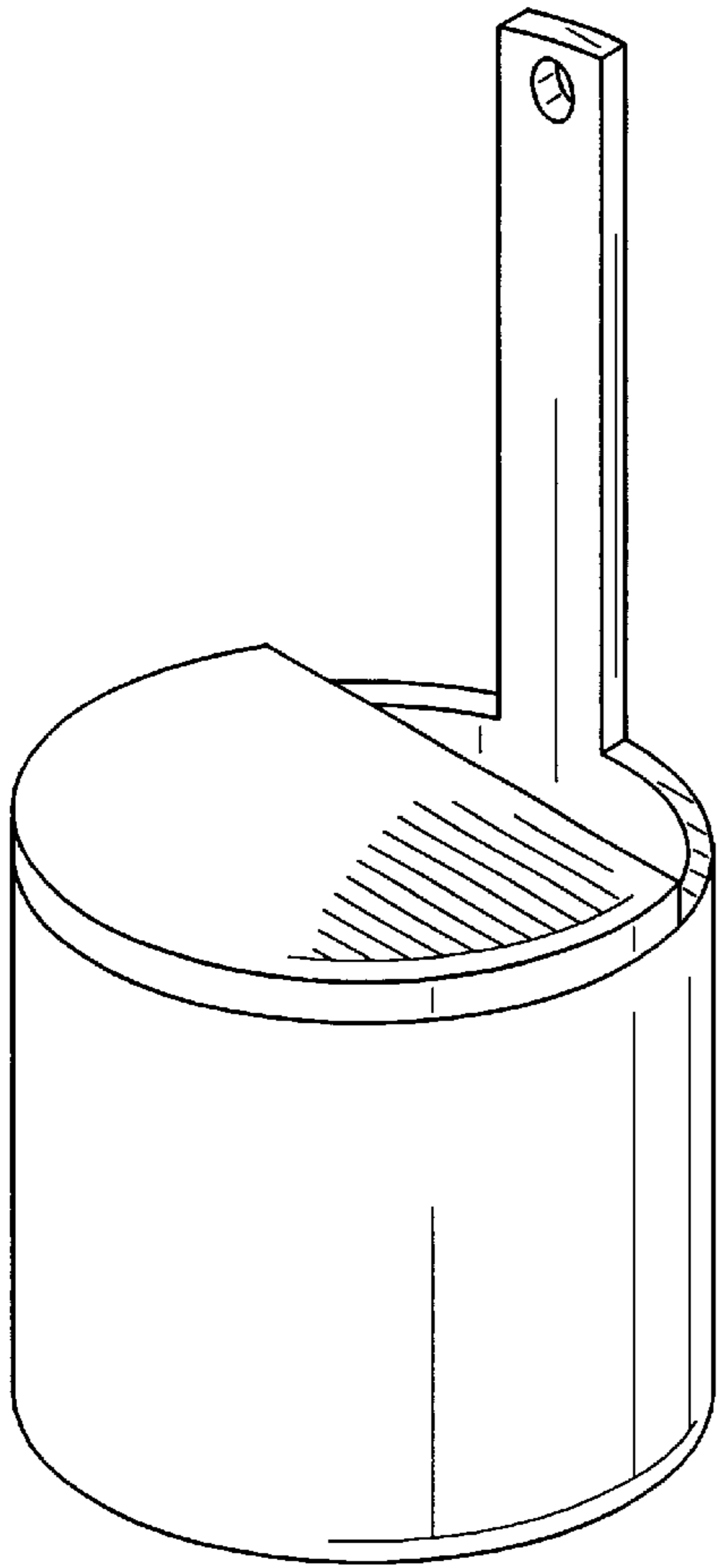

FIG. 1

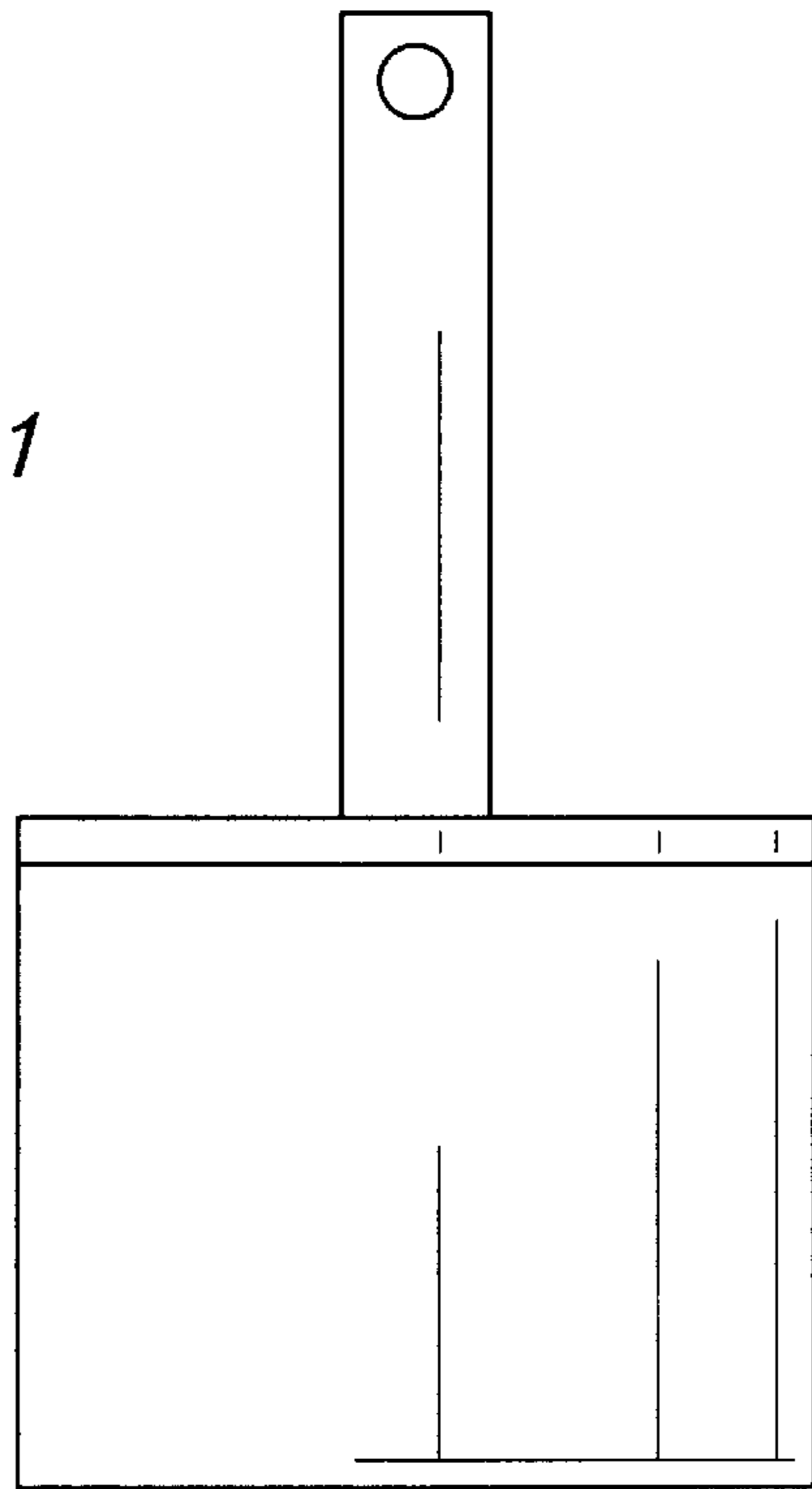

FIG. 2

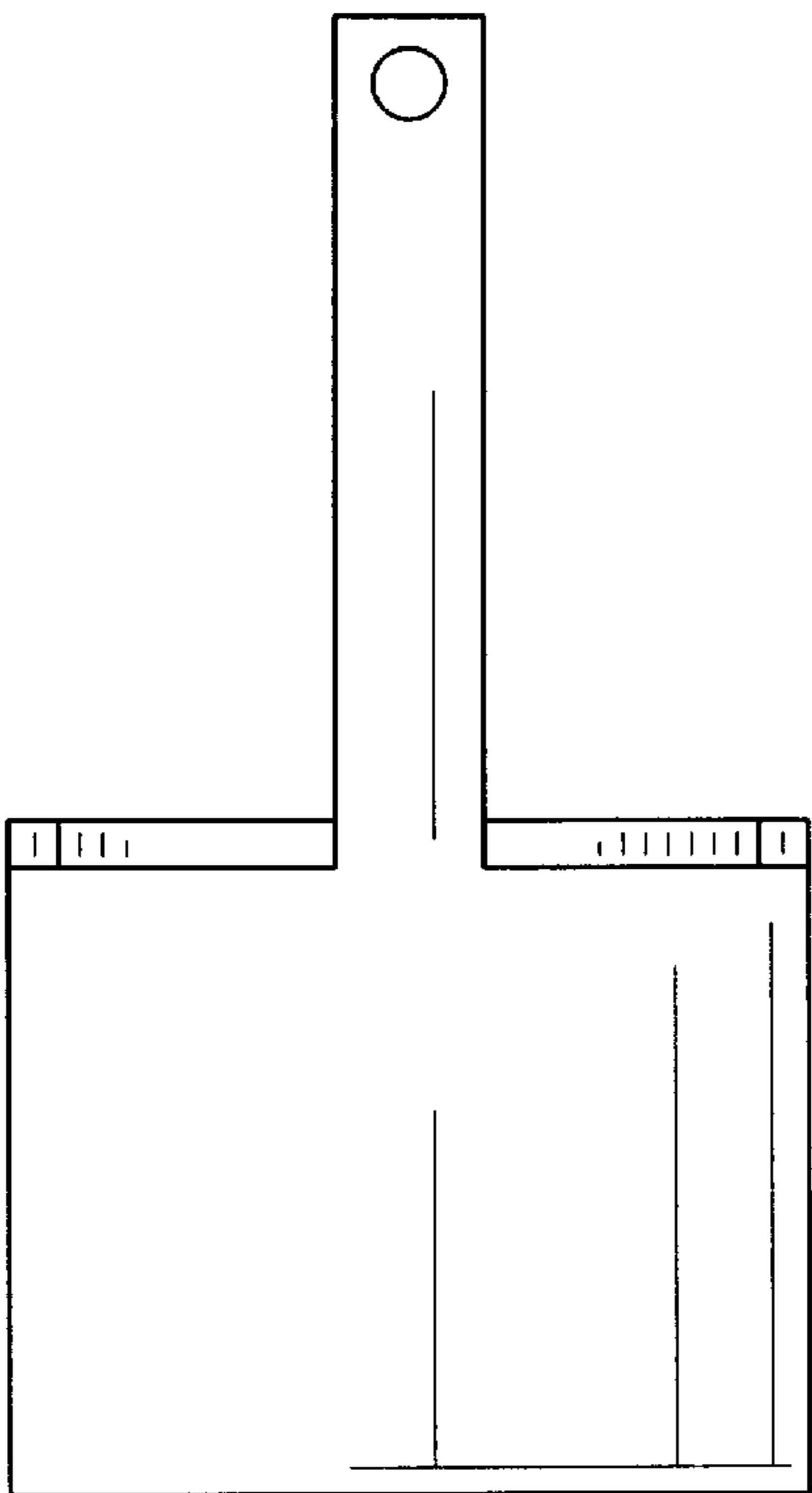

FIG. 3

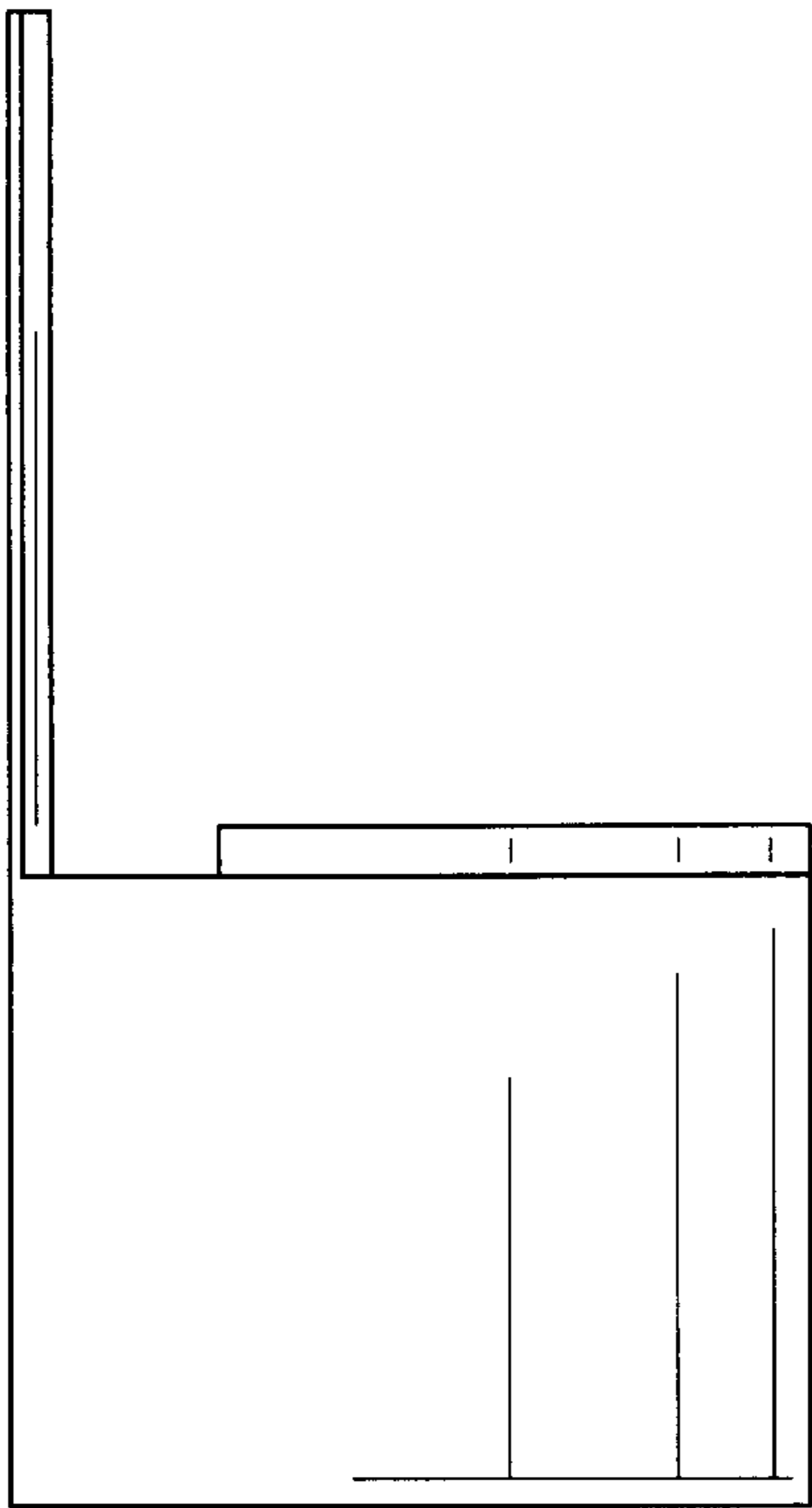

FIG. 4

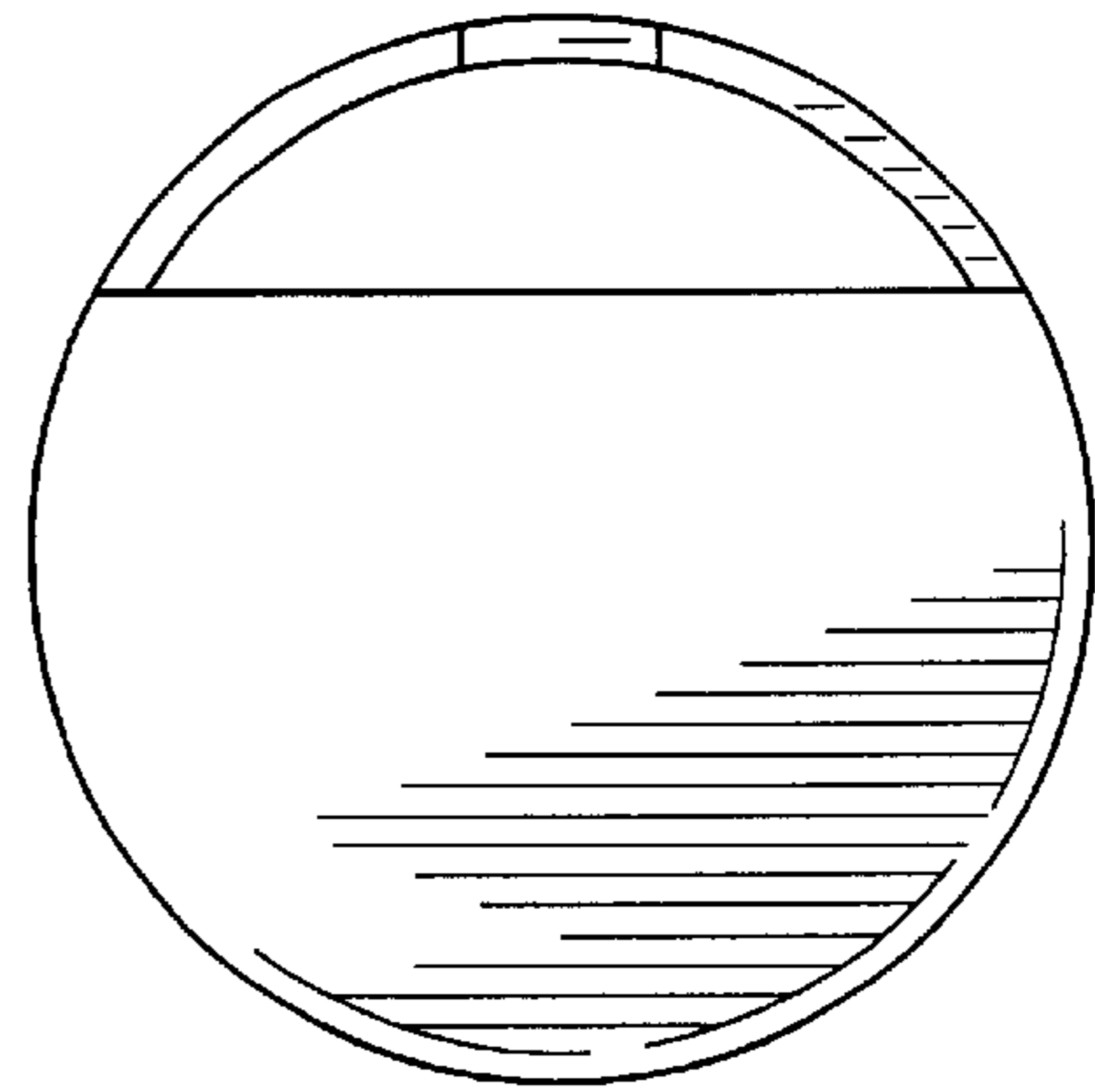

FIG. 5

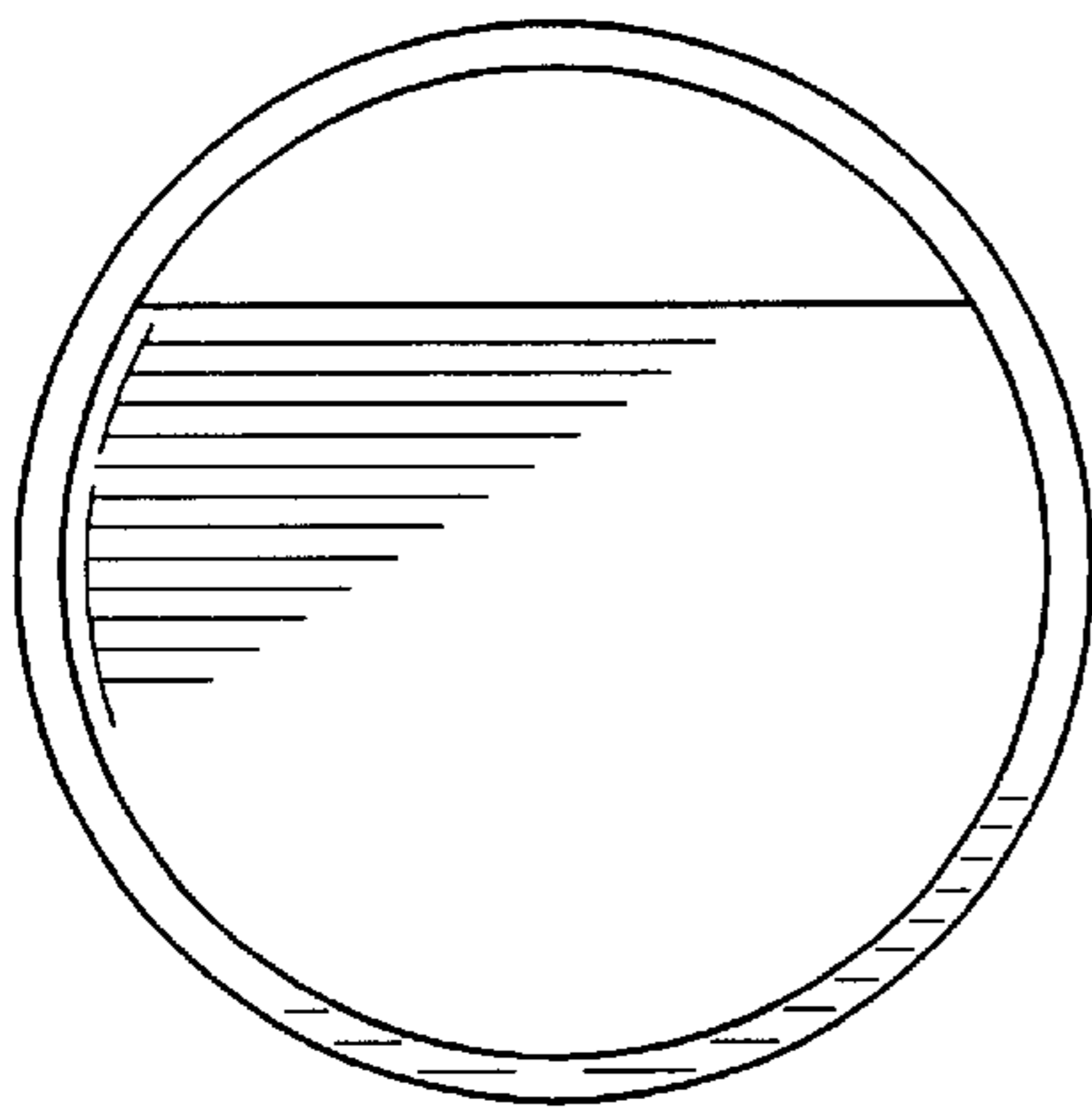

FIG. 6