



US00D486532S

(12) **United States Design Patent**
Christianson

(10) **Patent No.:** **US D486,532 S**

(45) **Date of Patent:** **** Feb. 10, 2004**

(54) **SCOOTER**

(75) **Inventor:** **Tristan M. Christianson**, San Francisco, CA (US)

(73) **Assignee:** **Sharper Image Corporation**, San Francisco, CA (US)

(**) **Term:** **14 Years**

(21) **Appl. No.:** **29/183,239**

(22) **Filed:** **Jun. 9, 2003**

(51) **LOC (7) Cl.** **21-01**

(52) **U.S. Cl.** **D21/423**

(58) **Field of Search** D21/419, 421,
D21/423, 424, 426, 435, 533, 760, 765,
771; D12/107, 110-112; 280/87.01, 87.04,
87.041, 87.042, 87.05; 180/180, 181, 216,
219

(56) **References Cited**

U.S. PATENT DOCUMENTS

5,775,452 A	7/1998	Patmont	180/181
5,848,660 A	* 12/1998	McGreen	280/87.041
D433,718 S	* 11/2000	McGreen	D21/423
6,173,976 B1	1/2001	Lee	280/87.05
D447,188 S	* 8/2001	Lan	D21/423
D450,355 S	* 11/2001	Chan	D21/423
D453,198 S	1/2002	Dudley	21/423
D454,377 S	3/2002	Hsu et al.	21/423
D456,461 S	4/2002	Koch	21/423
D467,199 S	12/2002	McClure	12/8

OTHER PUBLICATIONS

Catalog: *The Sharper Image*, "Electric Razor Scooter," JD070, p. 26; "Sharper Image Electric™ X2 Scooter," SI700, p.27; "Pocket Electric Bike," JD080, p.13 (Father's Day 2002).

Catalog: *The Sharper Image*, "Sharper Image Electric™ Scooter," SI700, p.11; "Electric Razor Scooter," JD070, p. 12; "Pocket Electric Bike," JD080, p. 13 (May 2002).

Catalog The Sharper Image, "Razor Scooter With Power-Up™ Electric Motor," SI751-SI752, p. 19; "Sharper Image Electric™ X2 Scooter," SI700, p. 20; "Pocket Electric Bike," JD080, p. 36 (Oct. 2002).

* cited by examiner

Primary Examiner—Raphael Barkai

(74) *Attorney, Agent, or Firm*—Fliesler Dubb Meyer & Lovejoy LLP

(57) **CLAIM**

The ornamental design for a scooter, as shown and described.

DESCRIPTION

FIG. 1 is a front perspective view of a scooter, showing my new design;

FIG. 2 is a rear perspective view thereof;

FIG. 3 is a rear elevation view thereof;

FIG. 4 is a front elevation view thereof;

FIG. 5 is a left side elevation view thereof;

FIG. 6 is a right side elevation view thereof;

FIG. 7 is a top plan view thereof; and,

FIG. 8 is a bottom plan view thereof.

The broken line showing on FIGS. 1-8 is for illustrative purposes only and forms no part of the claimed design.

1 Claim, 6 Drawing Sheets

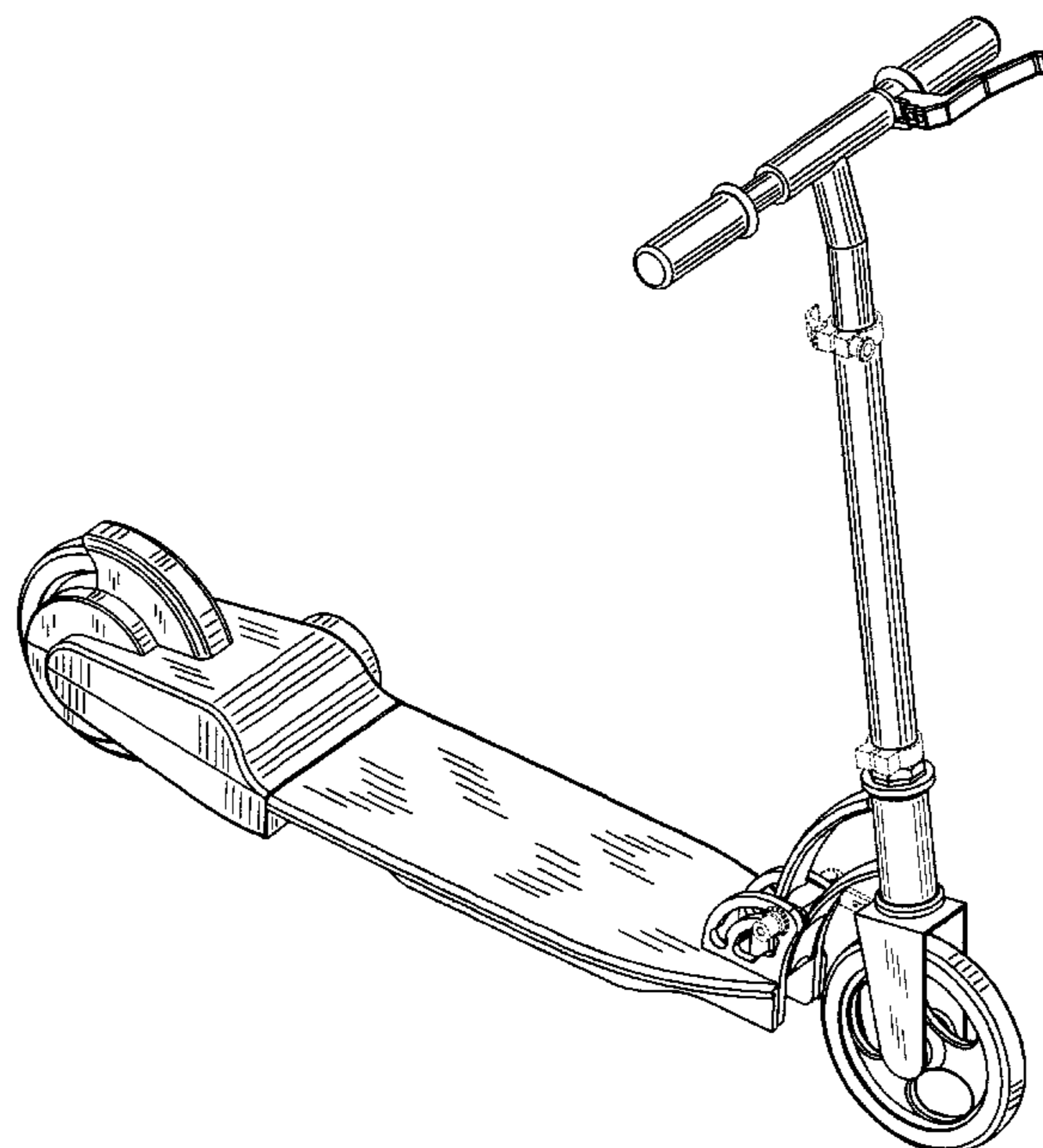

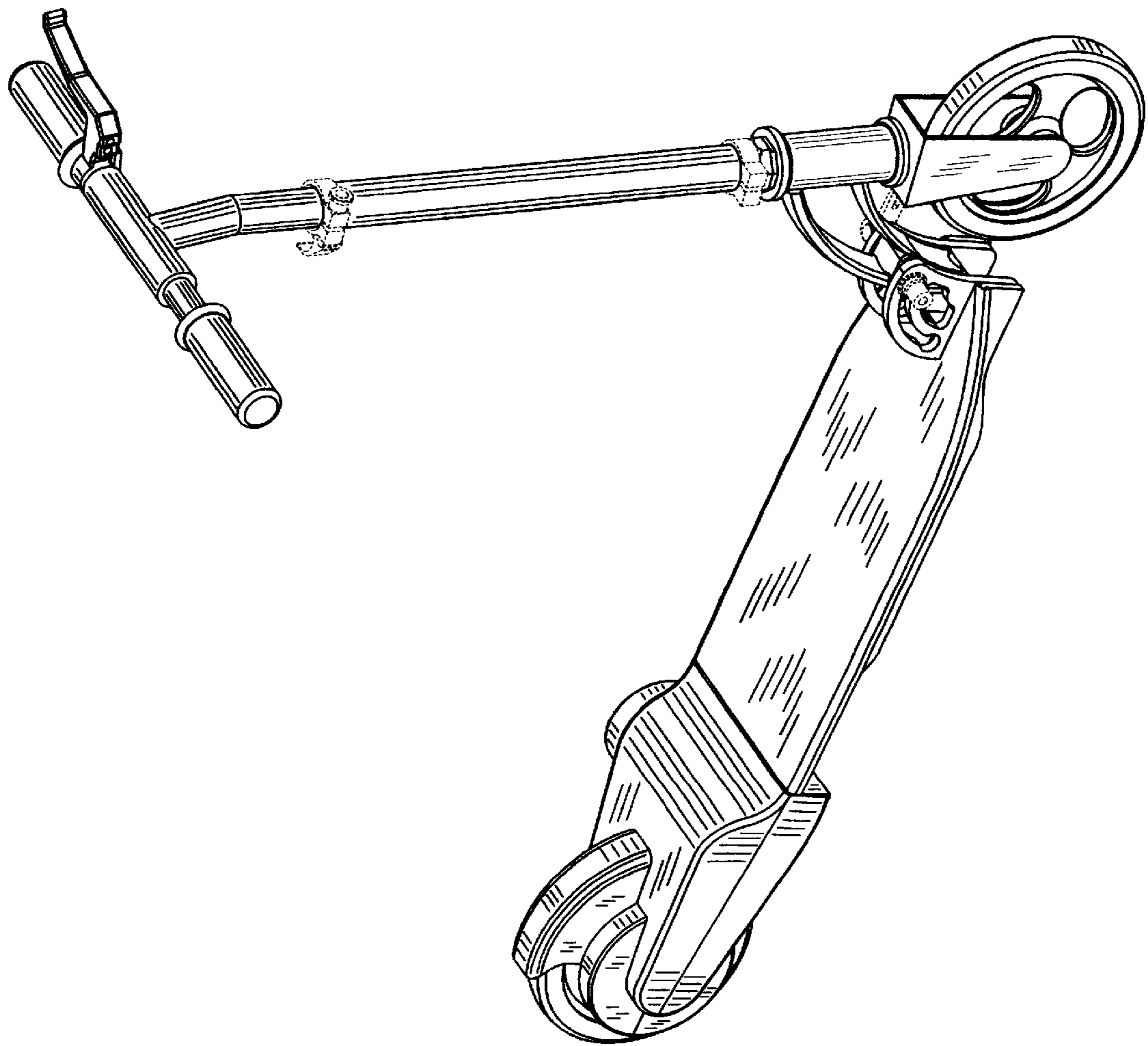

FIG. - 1

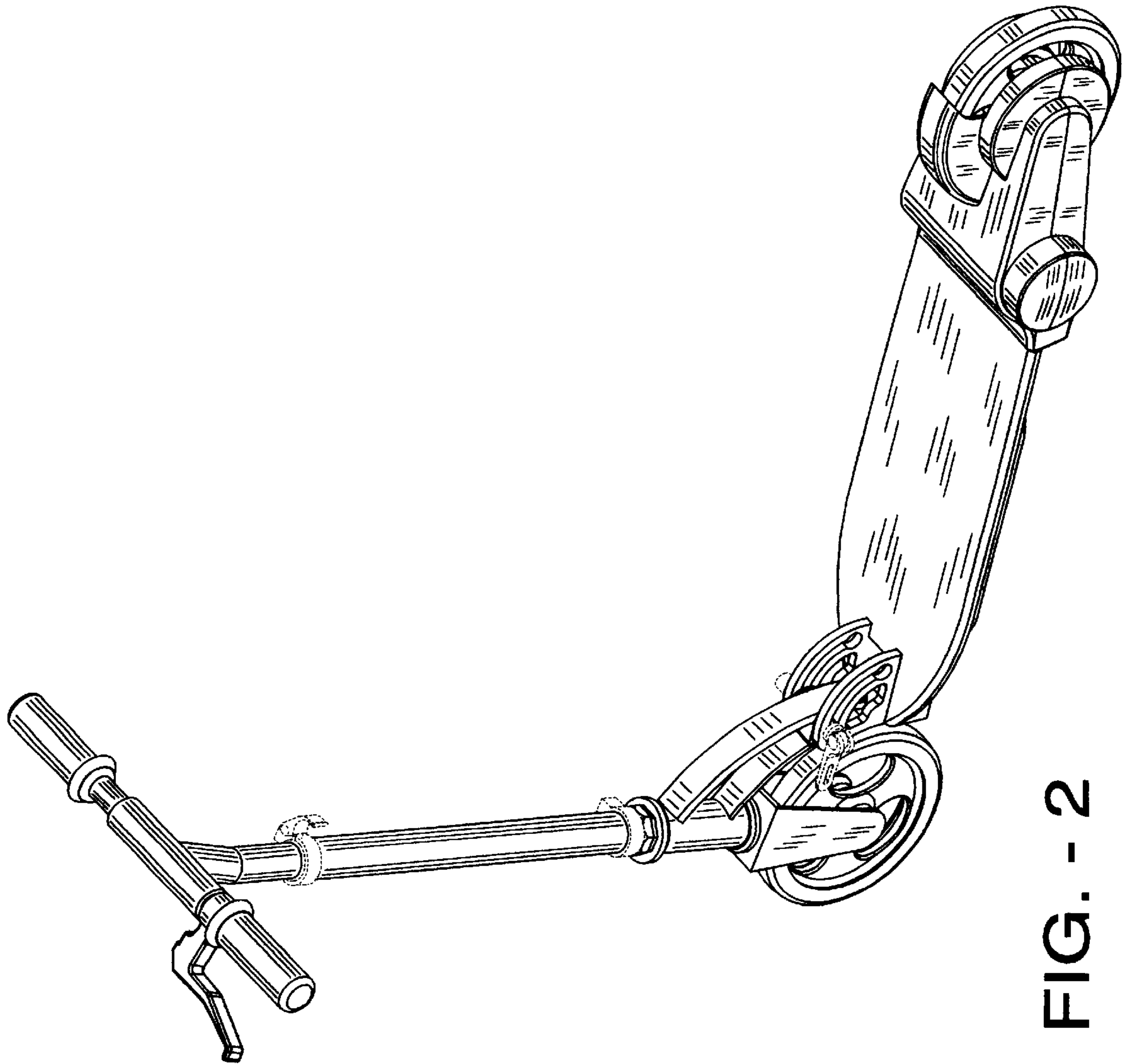

FIG. - 2

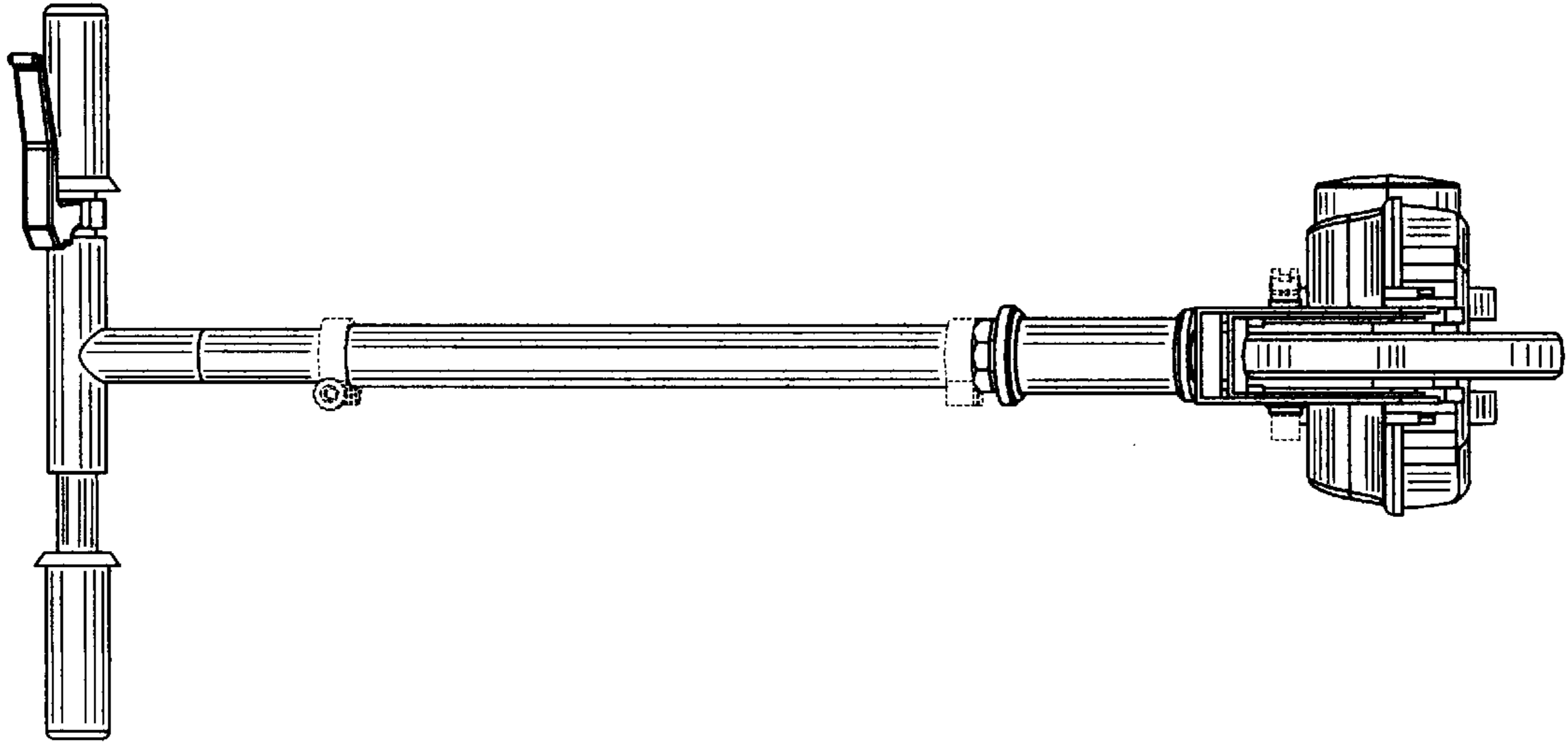

FIG. - 4

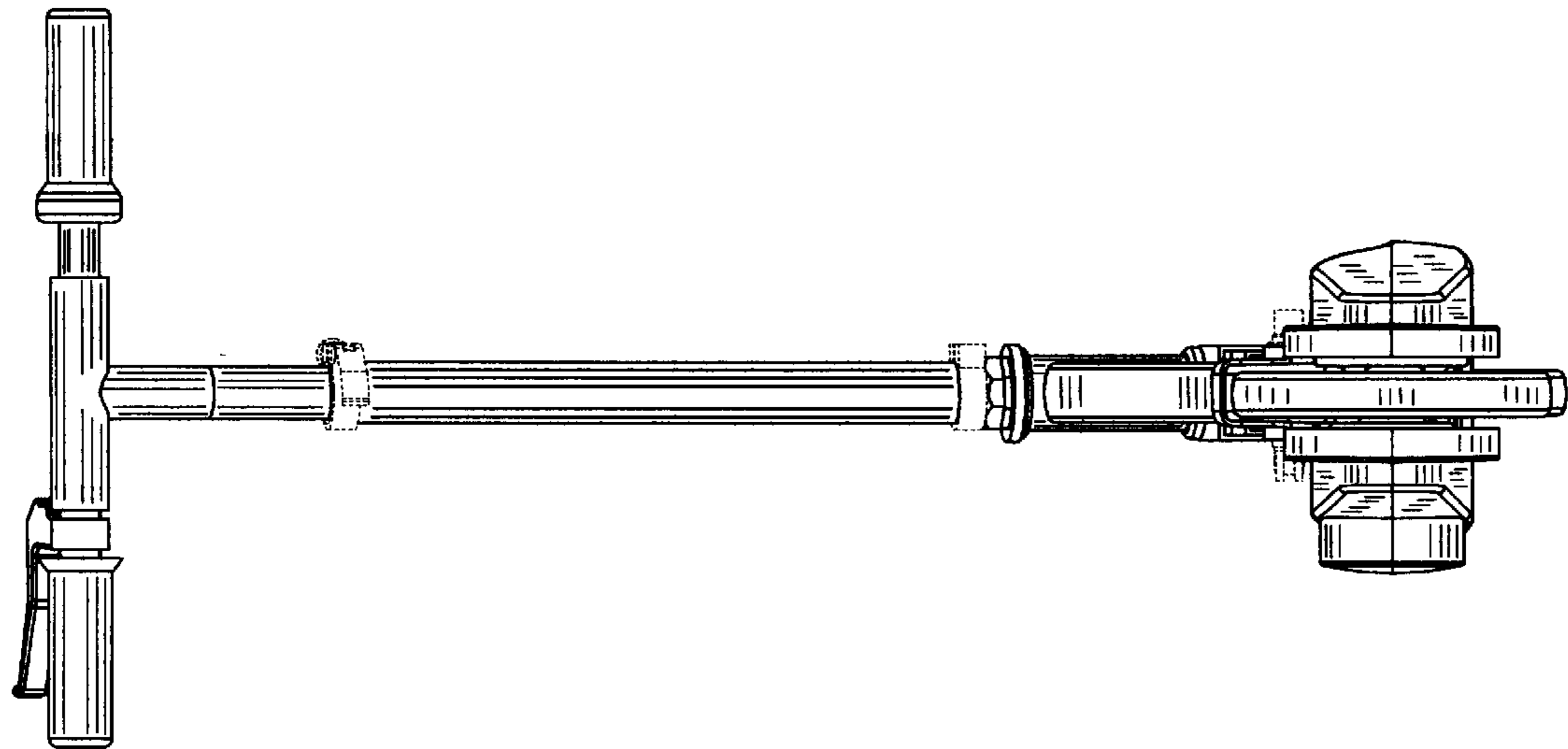

FIG. - 3

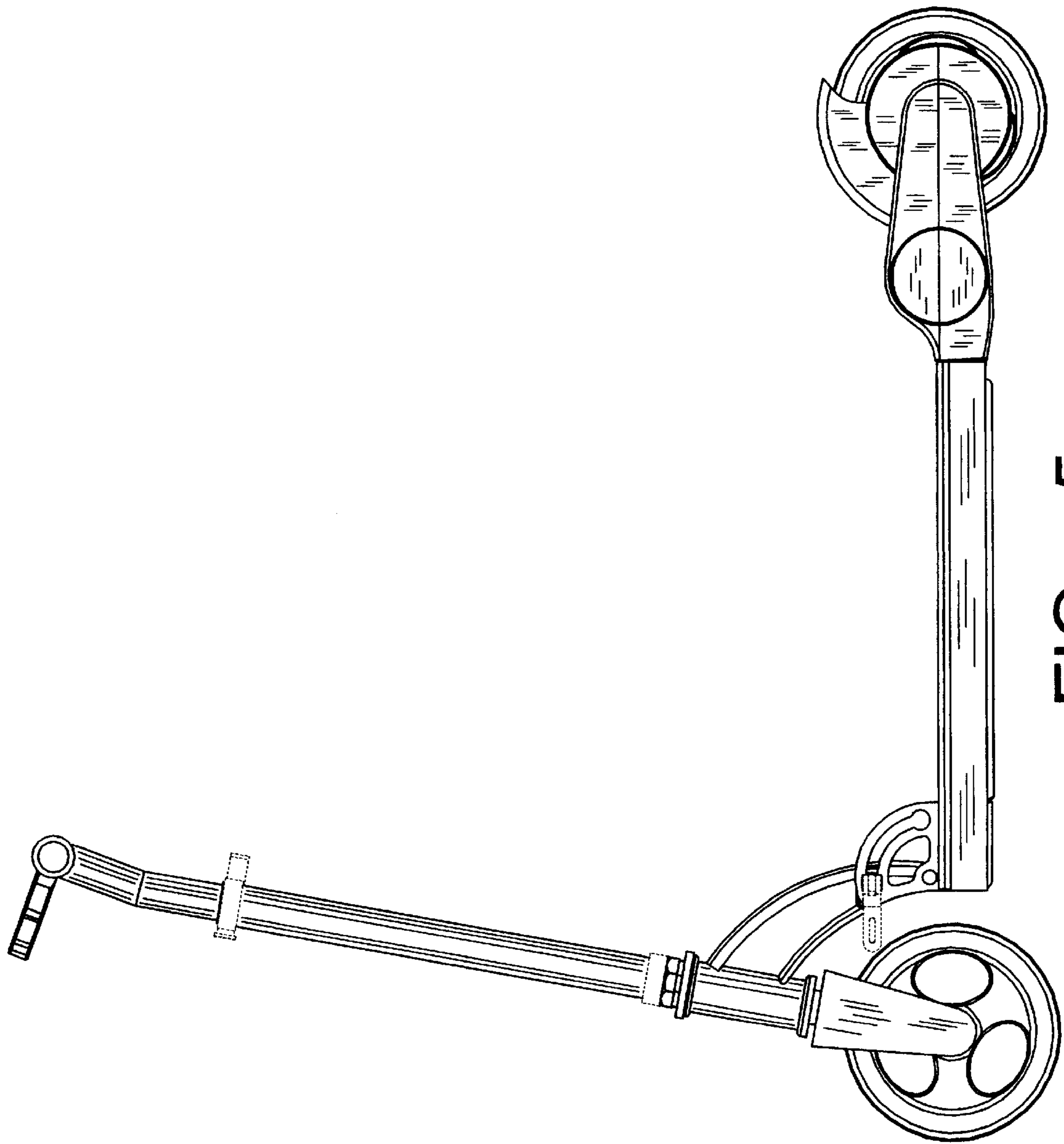

FIG. - 5

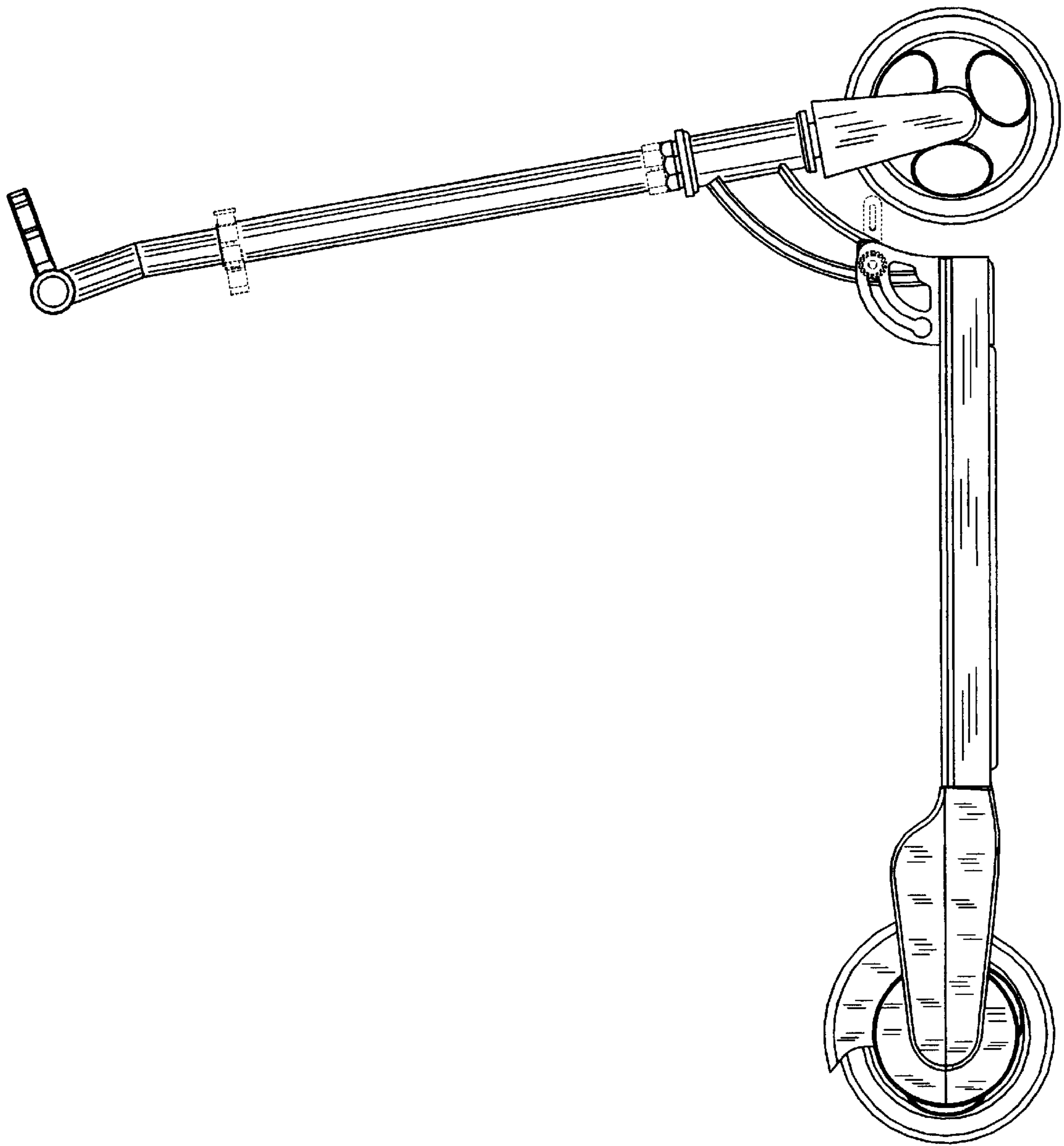

FIG. - 6

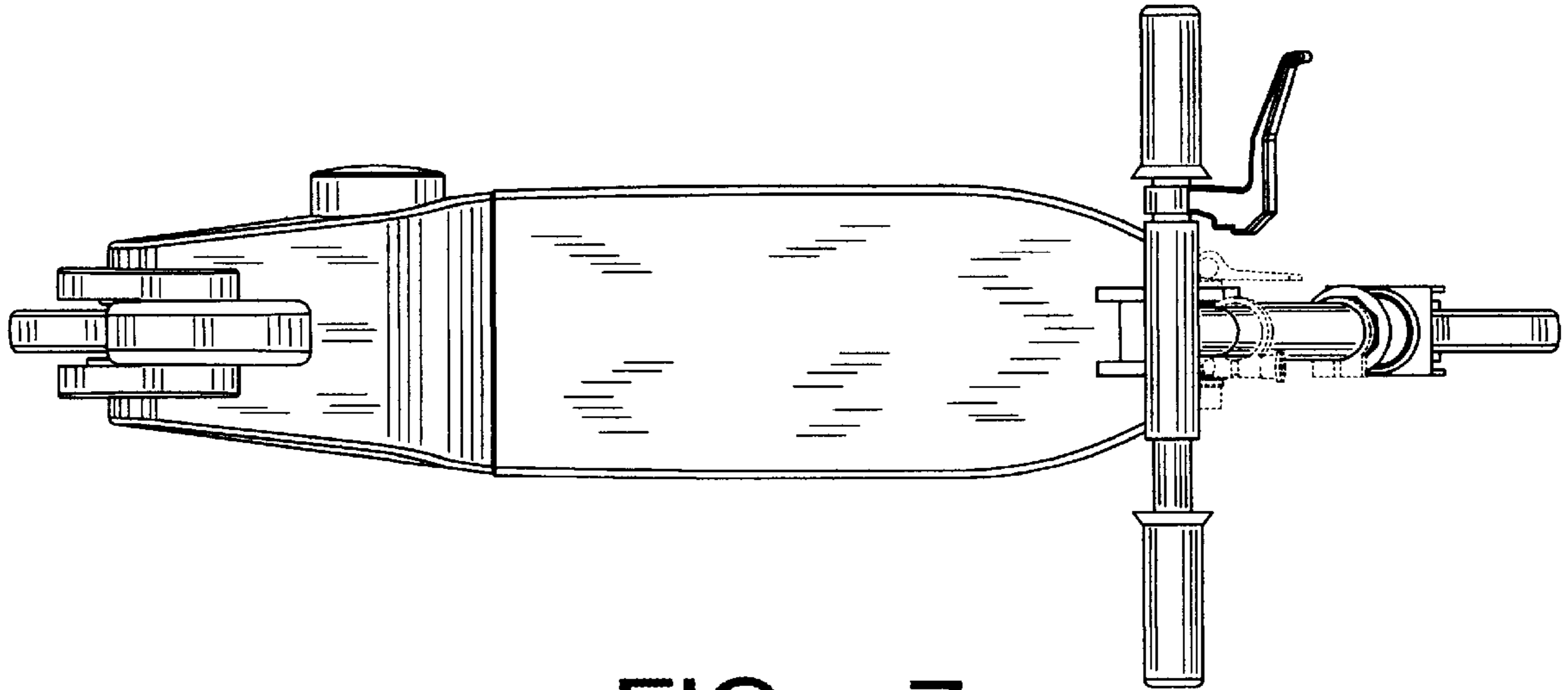

FIG. - 7

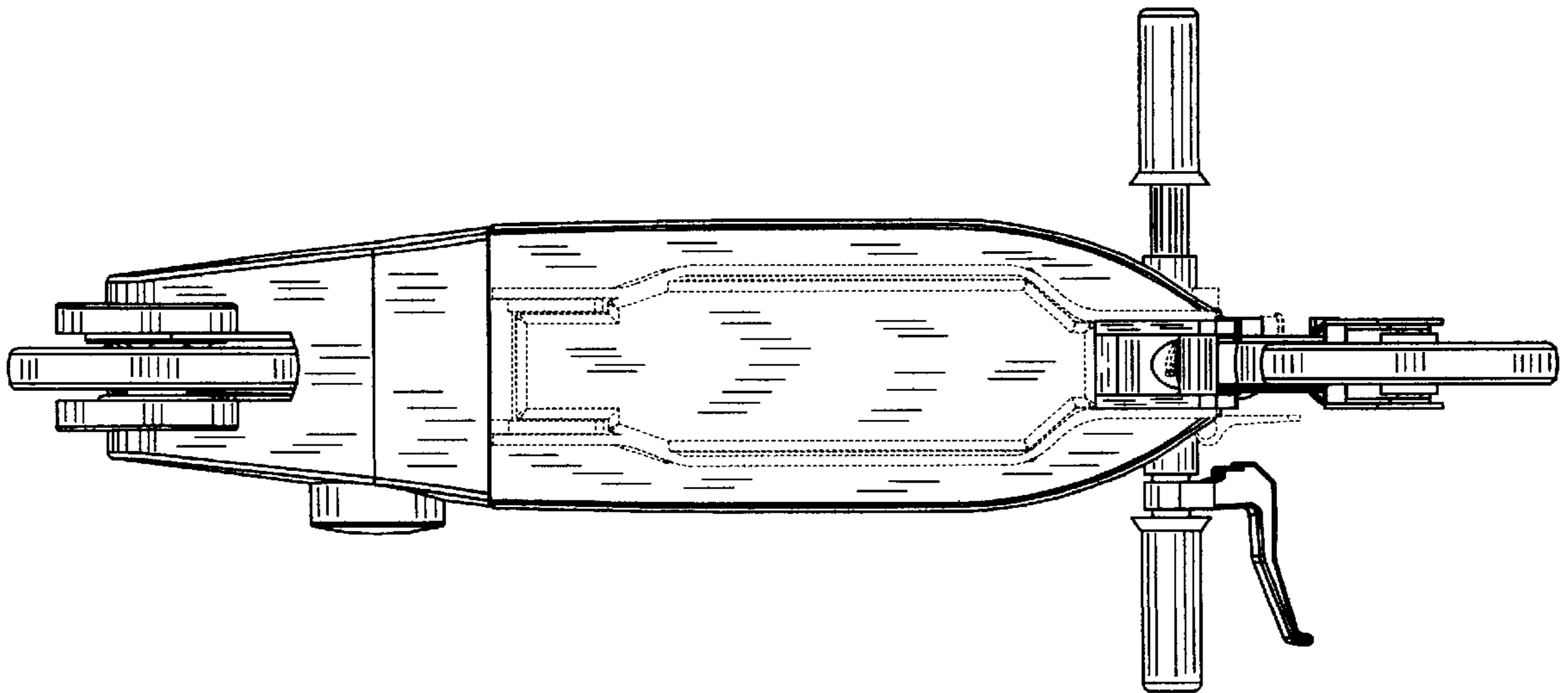

FIG. - 8