



US00D486409S

(12) **United States Design Patent Grant**

(10) **Patent No.: US D486,409 S**

(45) **Date of Patent: \*\* Feb. 10, 2004**

(54) **FUEL PRESSURE REGULATOR**

FOREIGN PATENT DOCUMENTS

(76) Inventor: **Barry S. Grant**, Rte. 1, Box 1900, Dahlenega, GA (US) 30533

DE 664158 8/1938

\* cited by examiner

(\*\*) Term: **14 Years**

*Primary Examiner*—Antoine Duval Davis  
(74) *Attorney, Agent, or Firm*—Thomas, Kayden, Horstemeyer & Risley

(21) Appl. No.: **29/169,250**

(22) Filed: **Oct. 16, 2002**

(57) **CLAIM**

(51) **LOC (7) Cl.** ..... **10-04**

The ornamental design for a fuel pressure regulator, as shown and described.

(52) **U.S. Cl.** ..... **D10/96**

(58) **Field of Search** ..... D10/96; 137/505.41, 137/505.42, 15.69; 123/457; 50/4, 21, 23

**DESCRIPTION**

(56) **References Cited**

**U.S. PATENT DOCUMENTS**

1,410,089	A	3/1922	Wilkins	
1,465,654	A	8/1923	Radtke	
1,860,468	A	5/1932	MacLean	
2,049,382	A	7/1936	Deming	50/23
2,062,422	A	12/1936	Meese	251/48
2,105,876	A	1/1938	Birch	50/23
2,156,823	A	5/1939	Stettner	50/23
2,202,313	A	5/1940	Grove	50/21
2,215,597	A	9/1940	Semon et al.	50/23
2,674,829	A	4/1954	St. Clair	50/4
2,979,067	A	4/1961	Kern, Jr. et al.	137/15
3,168,903	A	2/1965	Pearl	137/505.42
4,111,222	A	9/1978	Hassell	137/69
5,113,831	A	5/1992	Grant	123/457
6,170,519	B1 *	1/2001	Carroll et al.	137/505.42
6,298,828	B1 *	10/2001	Concialdi	123/457
6,443,130	B1 *	9/2002	Turner et al.	123/457 X

FIG. 1 is an isometric view of the fuel pressure regulator, showing the mounting bracket and the fuel conduit fittings mounted to the body of the regulator;  
 FIG. 2 is a front view thereof;  
 FIG. 3 is a back view thereof;  
 FIG. 4 is a right side view thereof;  
 FIG. 5 is a left side view thereof;  
 FIG. 6 is a top view thereof;  
 FIG. 7 is a bottom view thereof; and  
 FIG. 8 is an isometric view of the fuel pressure regulator of FIG. 1, with the fuel conduit fittings and the mounting bracket removed therefrom;  
 FIG. 9 is a front view thereof;  
 FIG. 10 is a back view thereof;  
 FIG. 11 is a right side view thereof;  
 FIG. 12 is a left side view thereof;  
 FIG. 13 is a top view thereof; and  
 FIG. 14 is a bottom view thereof.

**1 Claim, 14 Drawing Sheets**

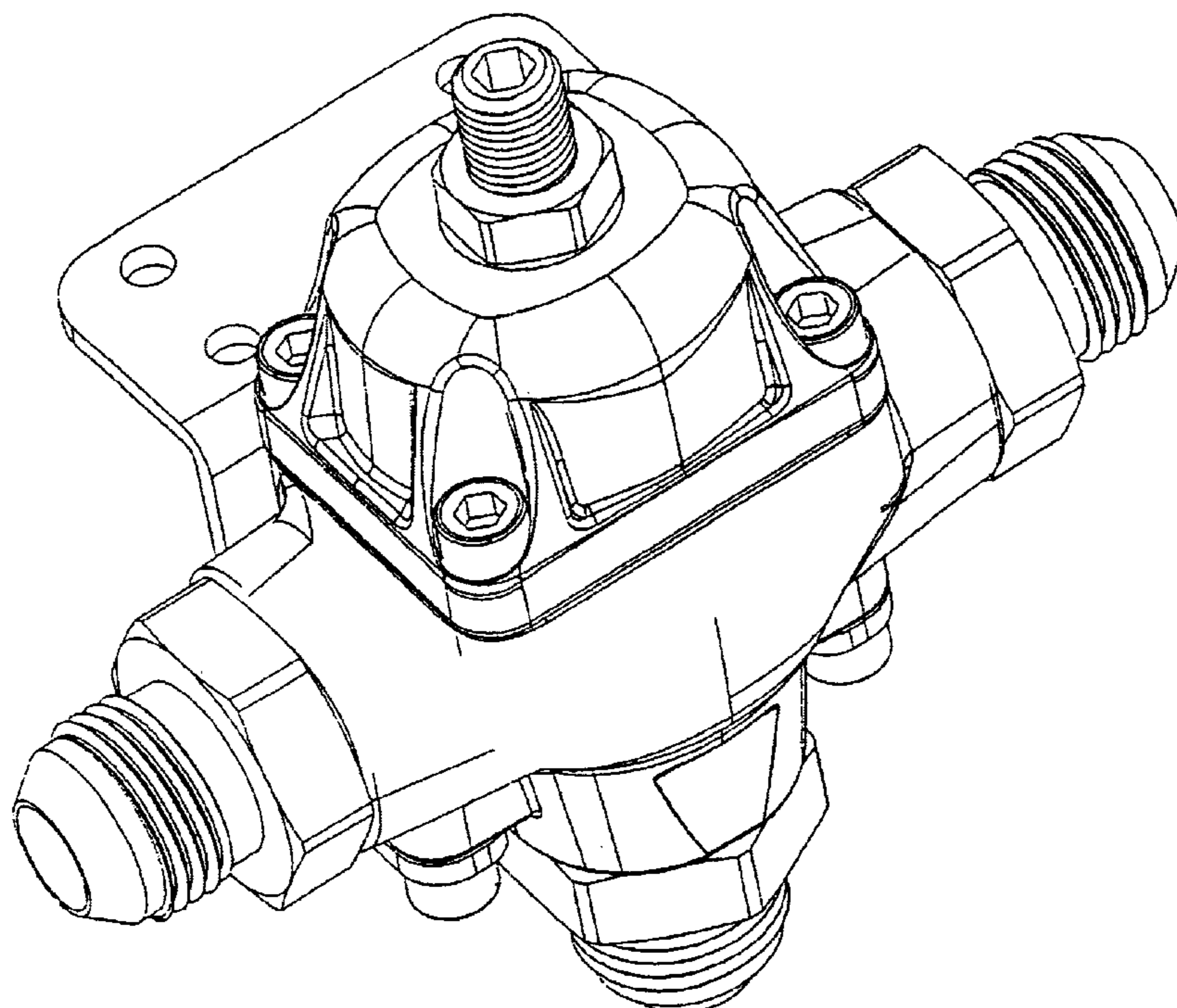

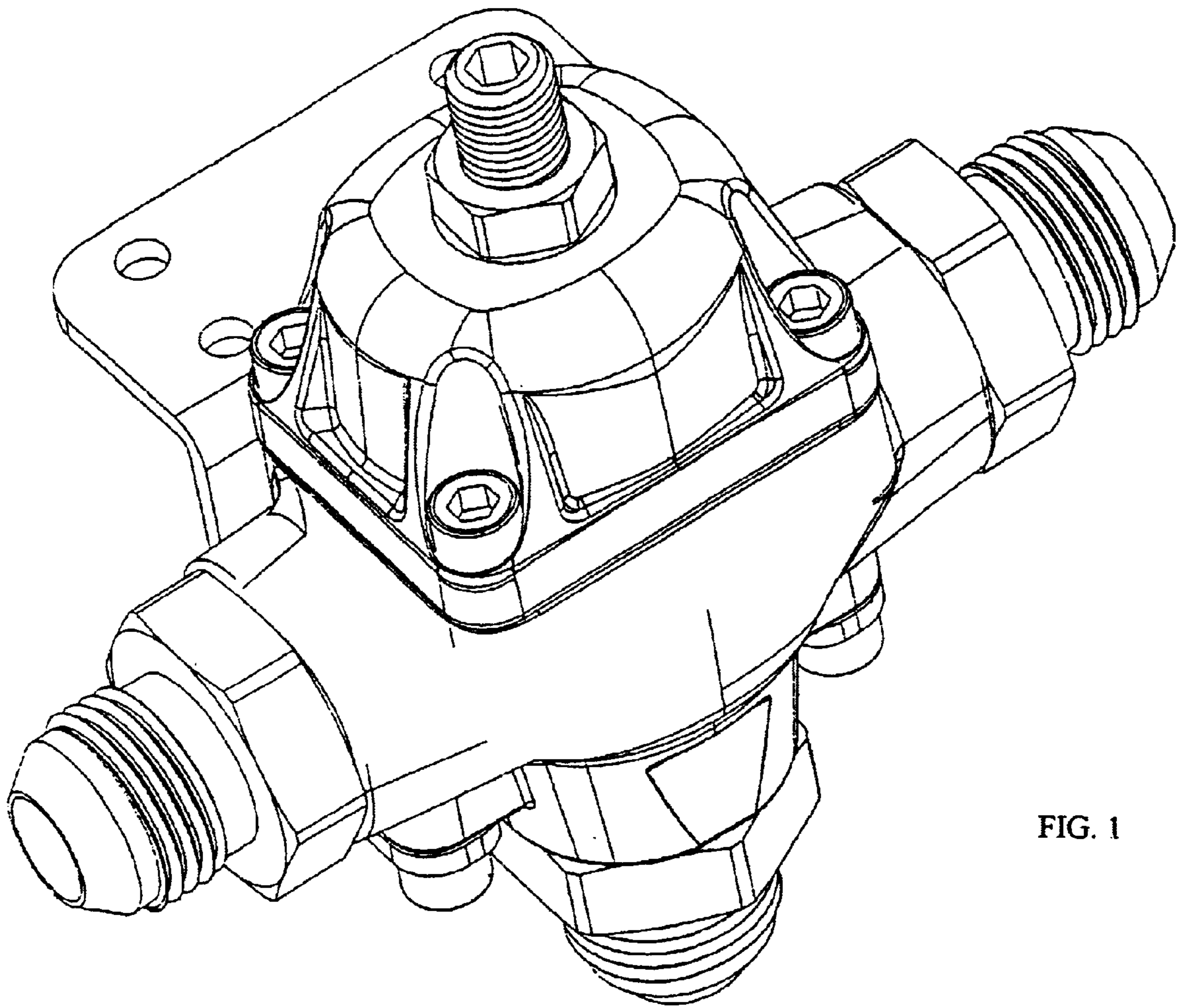

FIG. 1

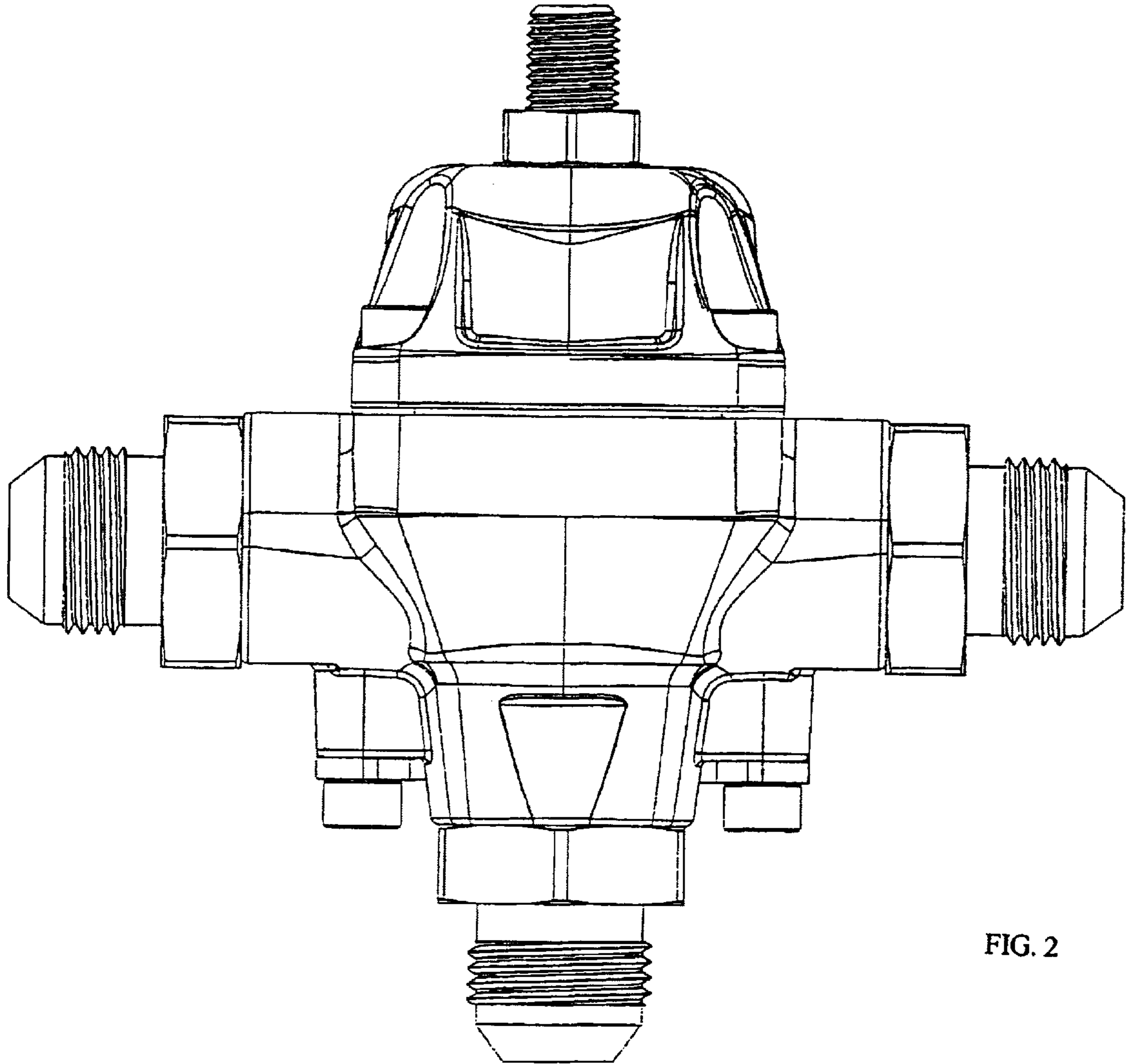

FIG. 2

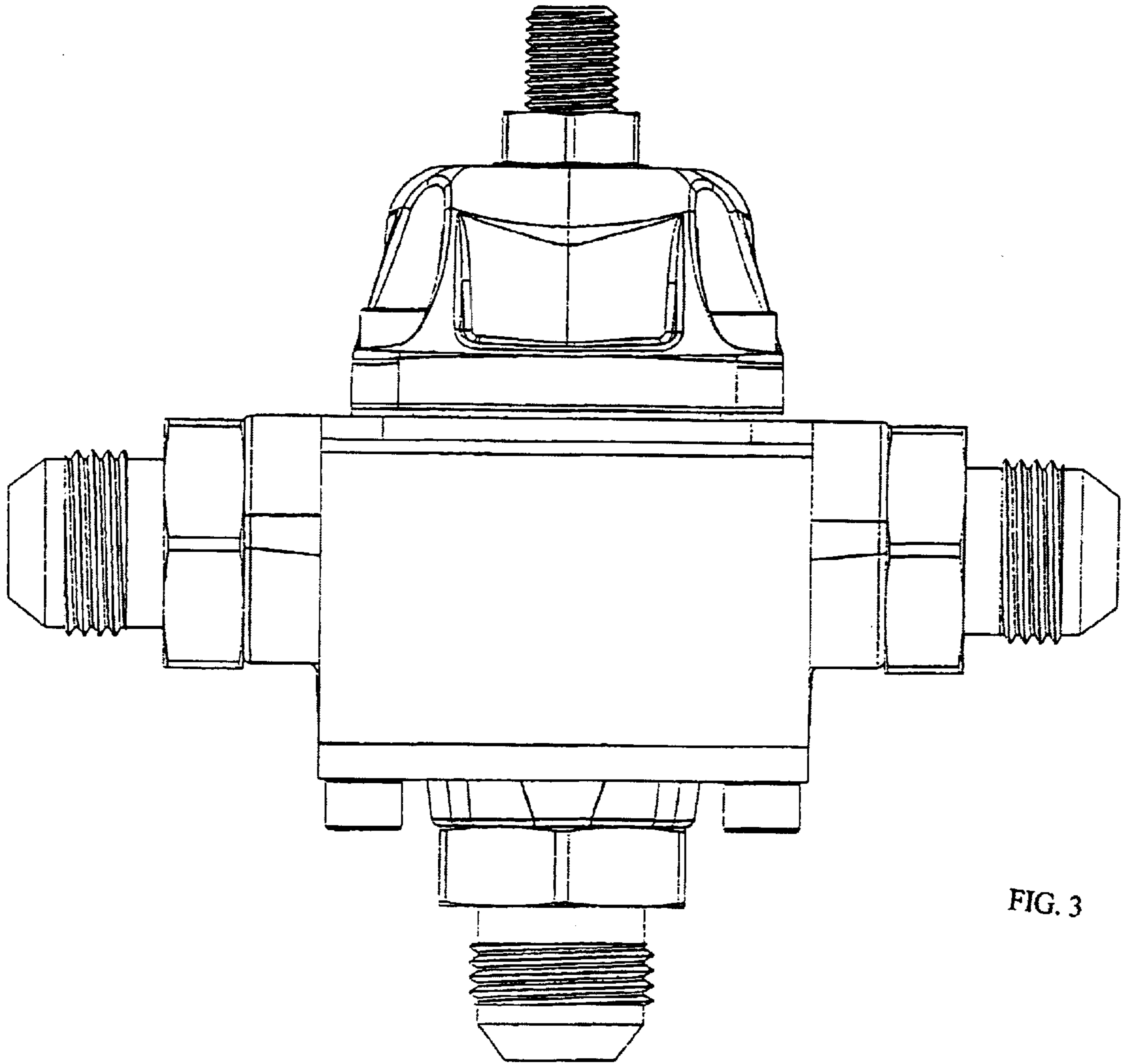

FIG. 3

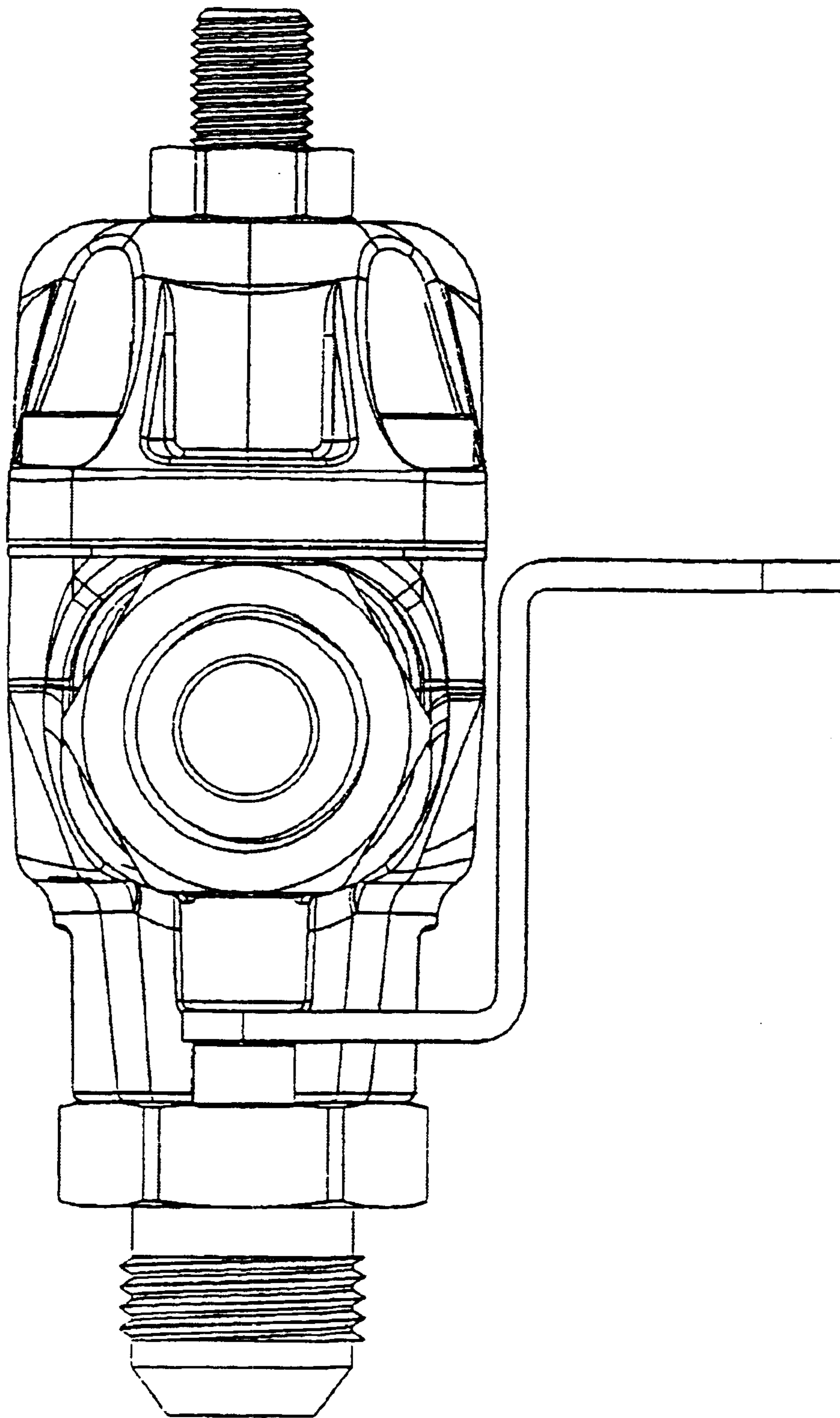

FIG. 4

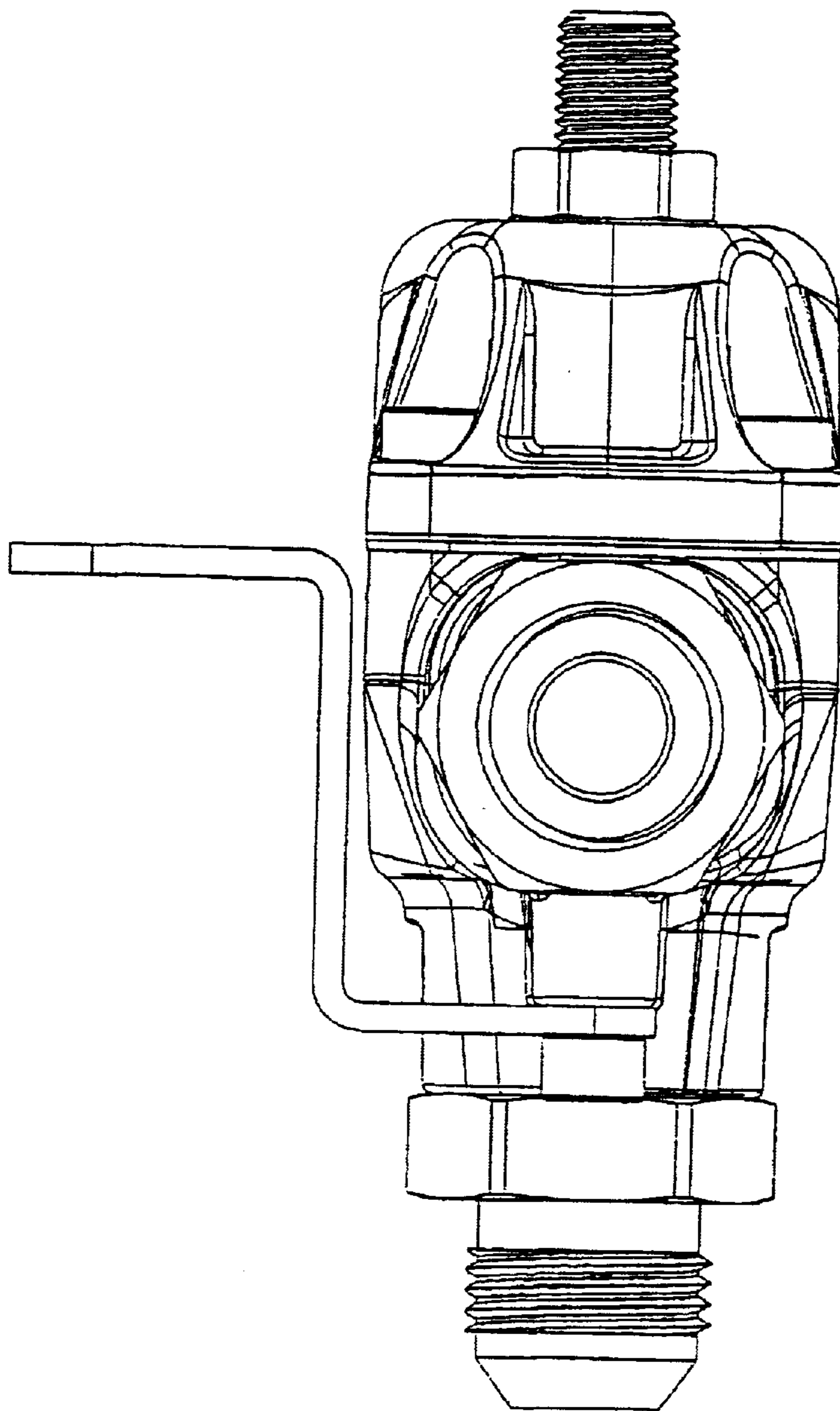

FIG. 5

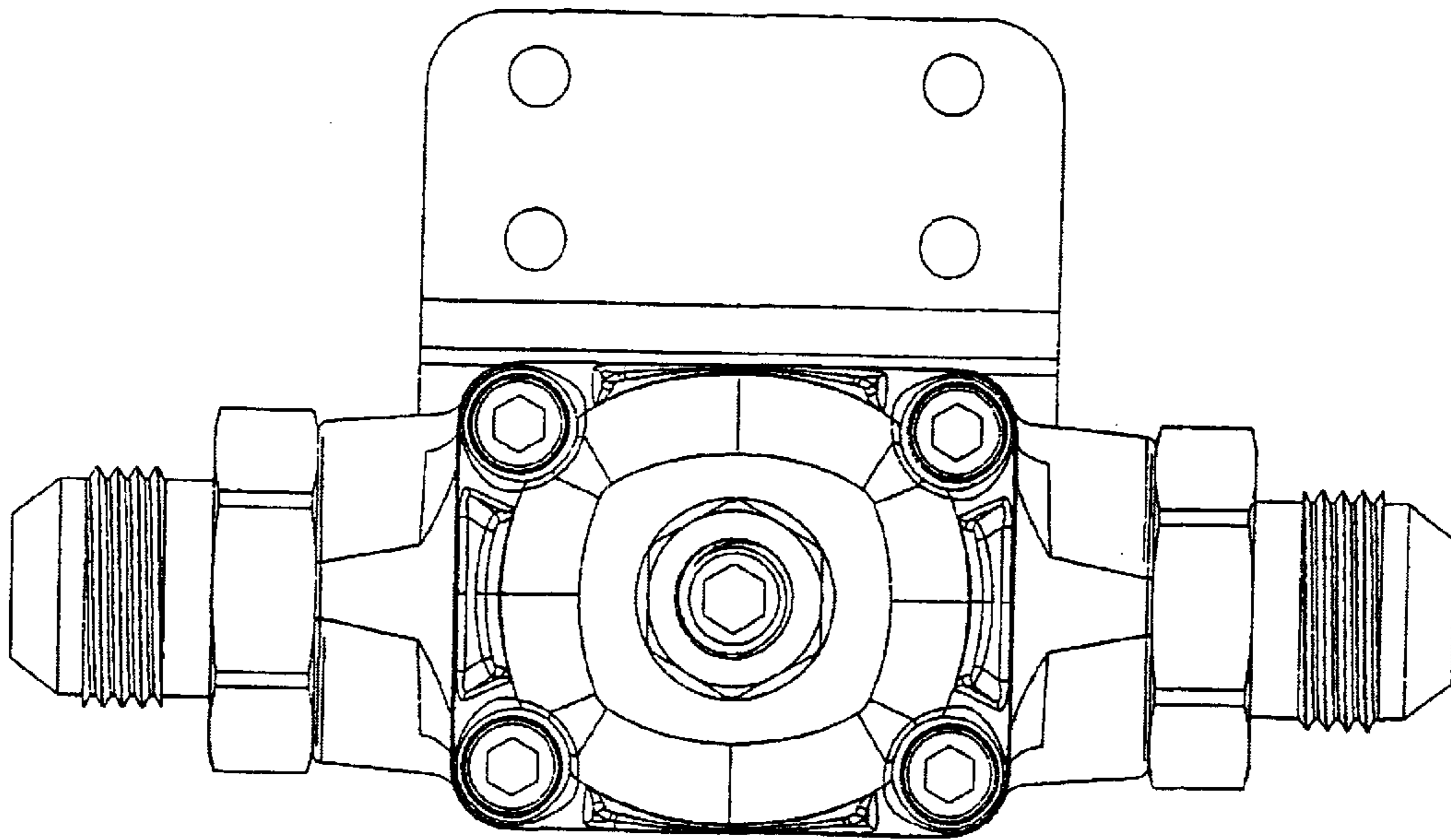

FIG. 6

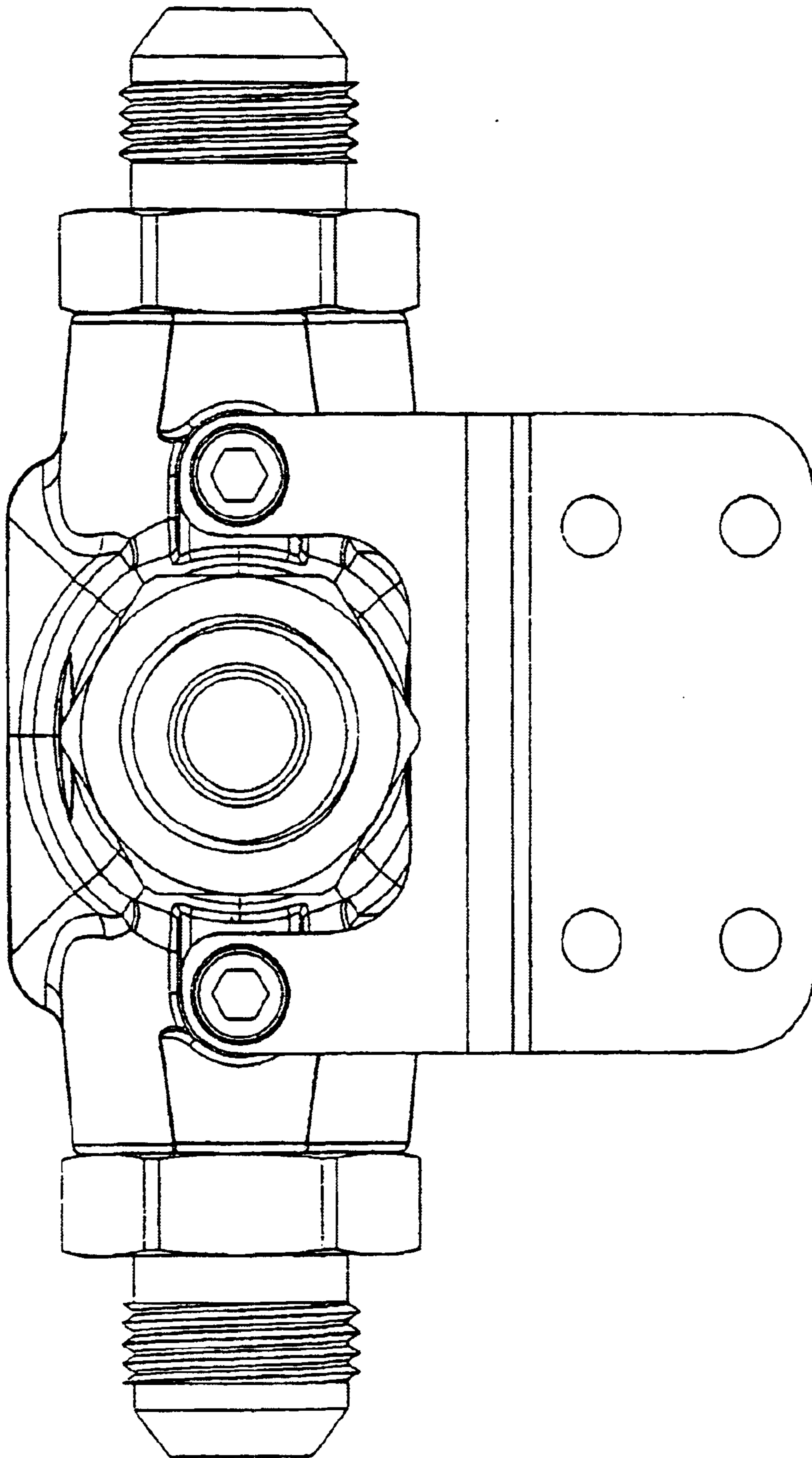

FIG. 7



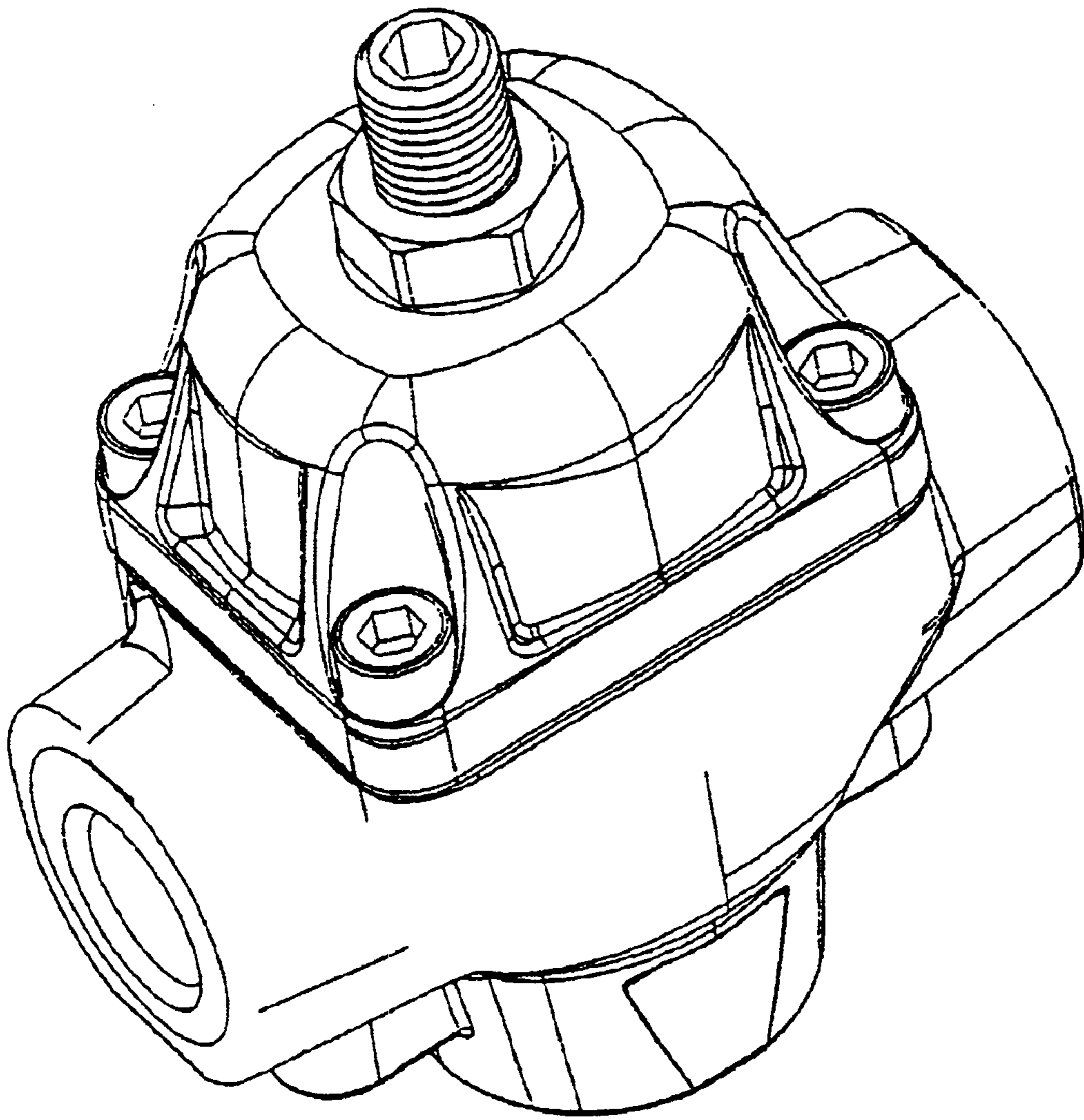

FIG. 8

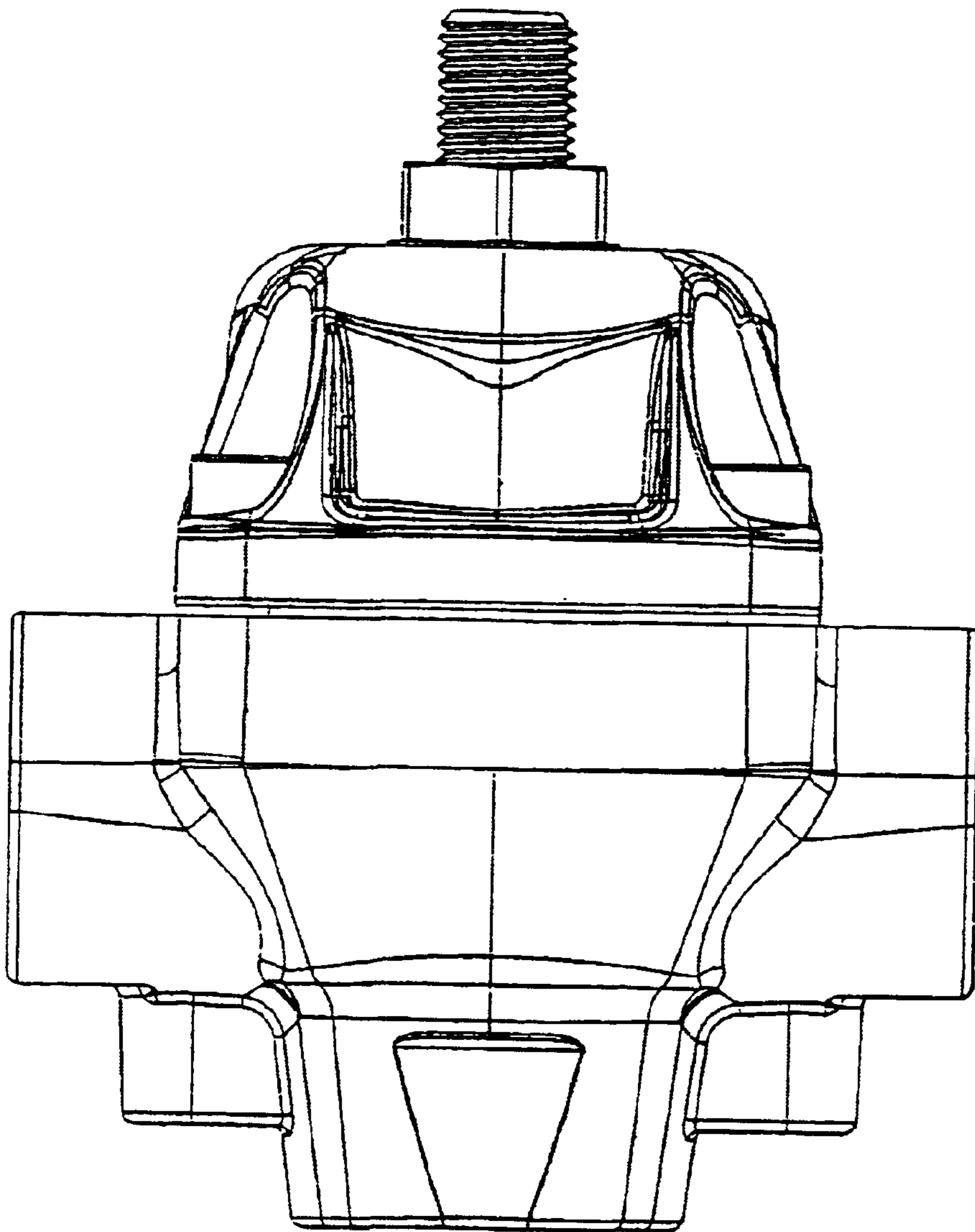

FIG. 9

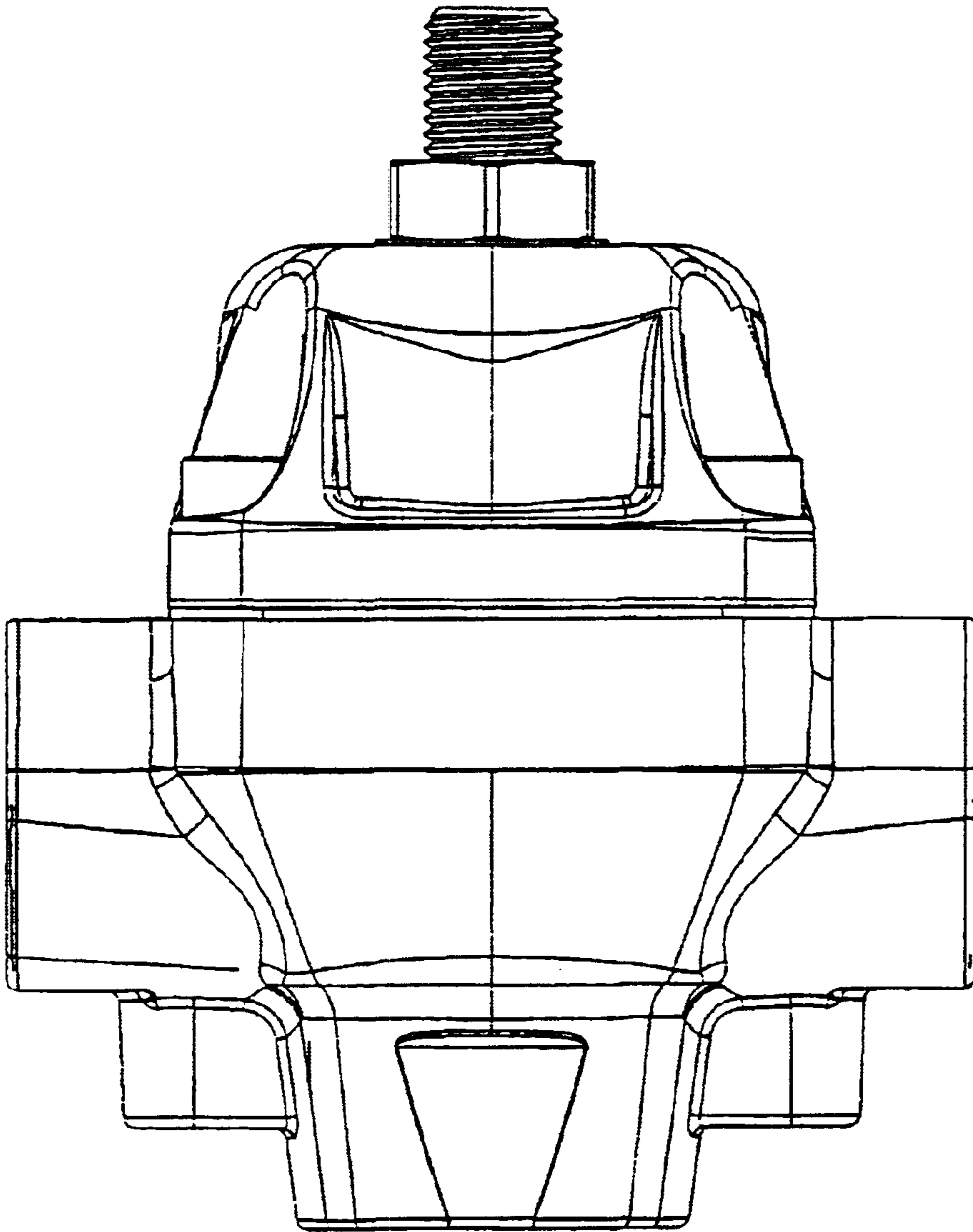

FIG. 10

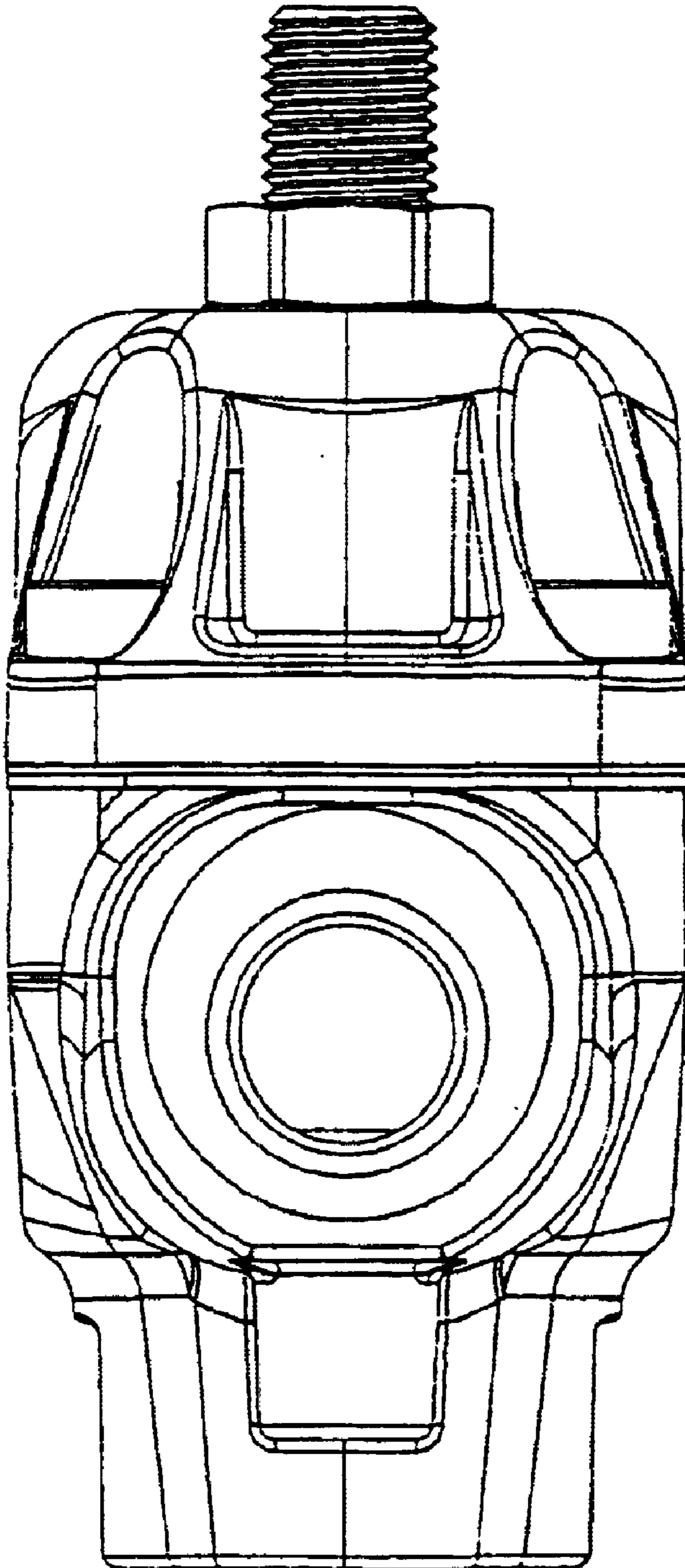

FIG. 11

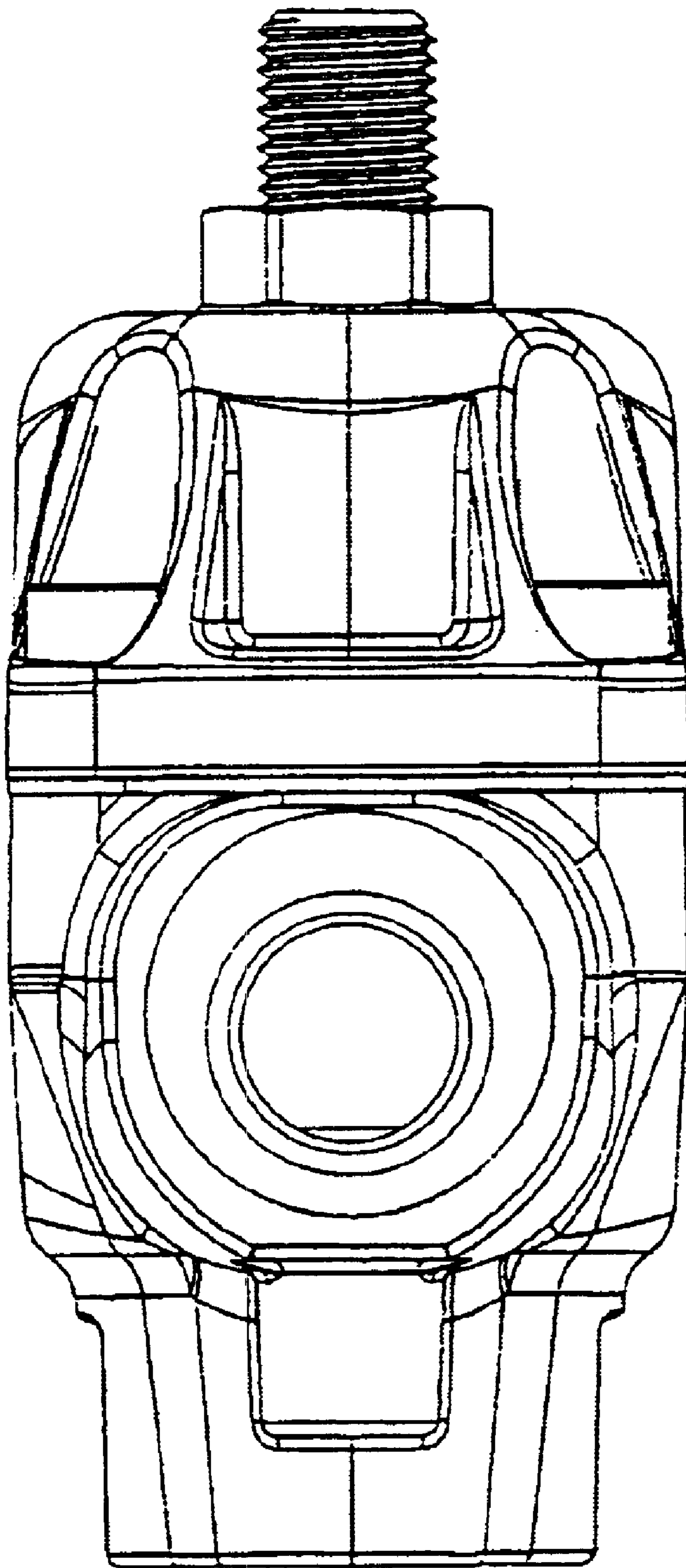

FIG. 12

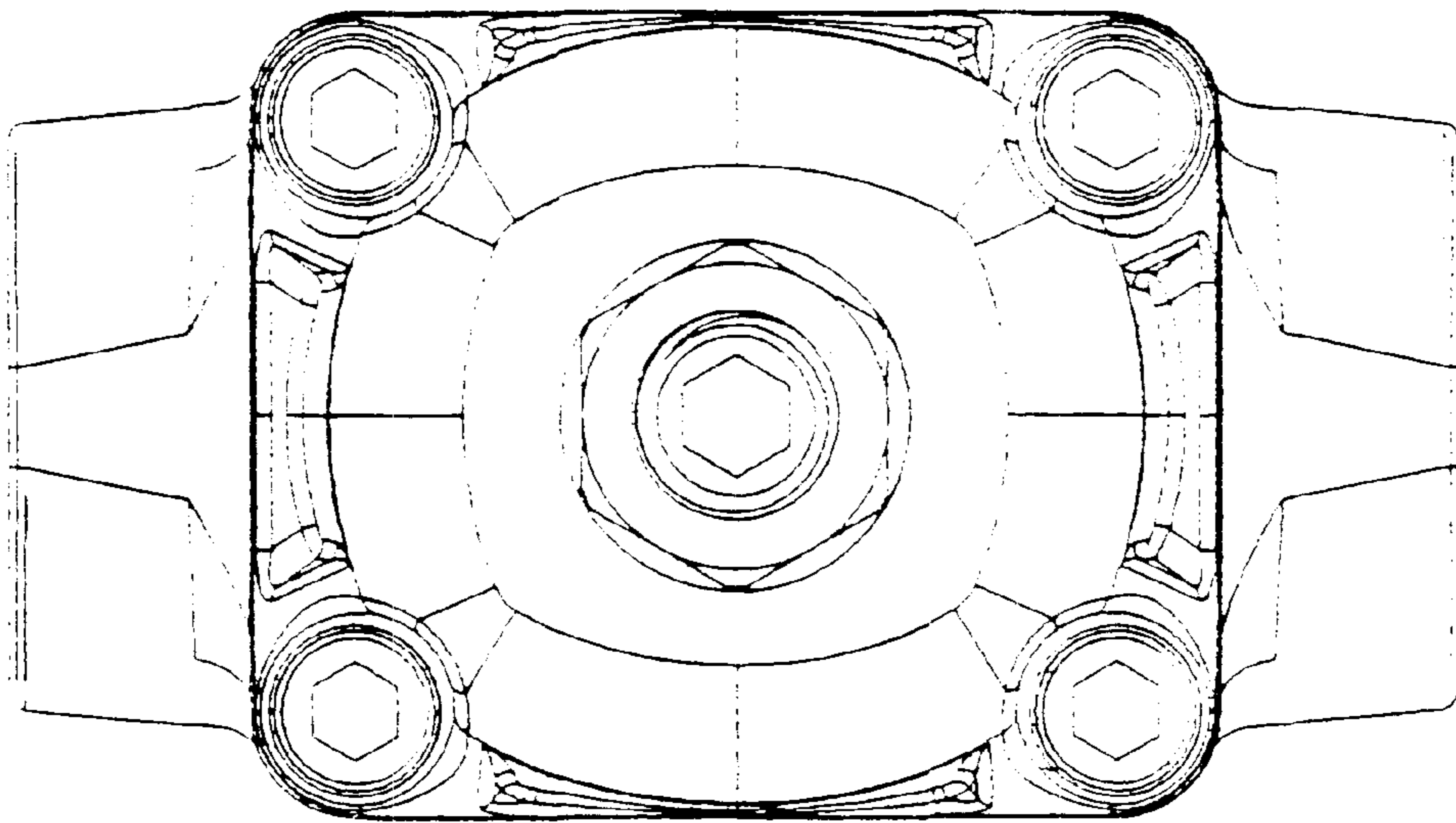

FIG. 13

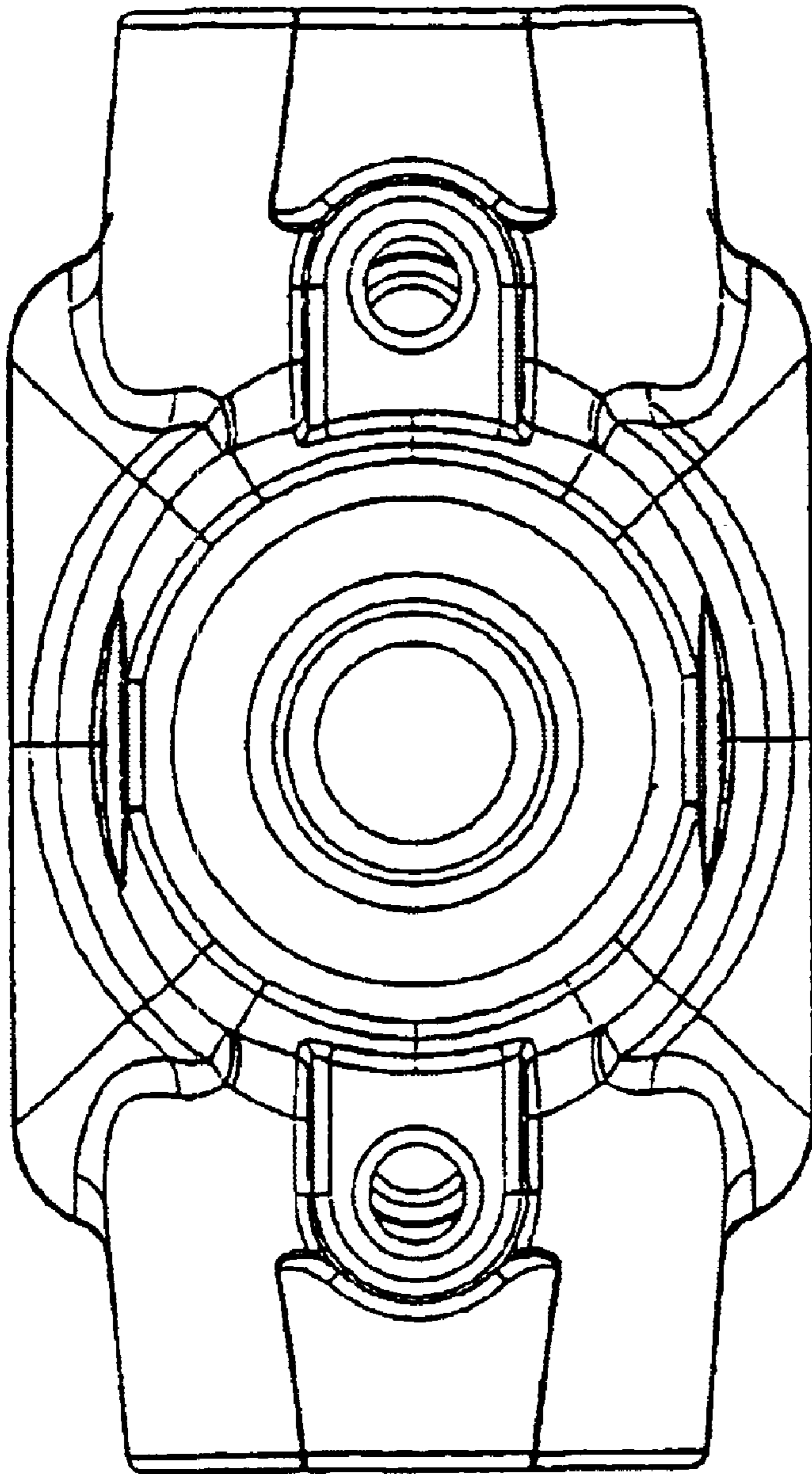

FIG. 14