



US00D486102S

(12) **United States Design Patent**
Perfetti et al.

(10) **Patent No.:** **US D486,102 S**

(45) **Date of Patent:** **** Feb. 3, 2004**

(54) **FRONT GRILLE FOR AN OVER THE HIGHWAY TRUCK**

(75) Inventors: **Ruben Perfetti**, Greensboro, NC (US);
John Martin, Madison, NC (US);
Martin Luckhaus, Gothenburg (SE)

(73) Assignee: **Volvo Trucks North America, Inc.**,
Greensboro, NC (US)

(**) Term: **14 Years**

(21) Appl. No.: **29/178,360**

(22) Filed: **Mar. 24, 2003**

(51) **LOC (7) Cl.** **12-16**

(52) **U.S. Cl.** **D12/163**

(58) **Field of Search** D12/163, 171,
D12/173, 96; 180/68.6, 89.1, 89.12, 89.14

(56) **References Cited**

U.S. PATENT DOCUMENTS

D289,627 S	*	5/1987	Okumura	D12/163
D404,697 S	*	1/1999	Siltavuori	D12/163
D411,140 S	*	6/1999	Meryman et al.	D12/96
D420,633 S	*	2/2000	Daniels et al.	D12/163

OTHER PUBLICATIONS

1 page section of a story board used by the inventors of the present application depicting competing trucks that were on the market when this design was completed, Dec. 31, 1999.

* cited by examiner

Primary Examiner—Melody N. Brown

(74) *Attorney, Agent, or Firm*—Watts Hoffmann Co, L.P.A.

(57) **CLAIM**

The ornamental design for an front grille for an over the highway truck, as shown and described.

DESCRIPTION

FIG. 1 is a perspective view showing one embodiment of a front grille for an over the highway truck of our new design; FIG. 2 is a perspective view of the front grille of FIG. 1; FIG. 3 is a front elevational view of the front grille of FIG. 1; FIG. 4 is a rear elevational view of the front grille of FIG. 1; FIG. 5 is a right side elevational view of the front grille of FIG. 1, the left side elevational view being a mirror image; FIG. 6 is a top plan view of the front grille of FIG. 1; FIG. 7 is a bottom plan view of the front grille of FIG. 1; FIG. 8 is a perspective view showing a second embodiment of a front grille for an over the highway truck of our new design; FIG. 9 is a front elevational view of the front grille of FIG. 8; FIG. 10 is a rear elevational view of the front grille of FIG. 8; FIG. 11 is a right side elevational view of the front grille of FIG. 8, the left side elevational view being a mirror image; and FIG. 12 is a top plan view of the front grille of FIG. 8; and, FIG. 13 is a bottom plan view of the front grille of FIG. 8. The broken lines shown are for illustrative purposes only and form no part of the claimed design.

1 Claim, 9 Drawing Sheets

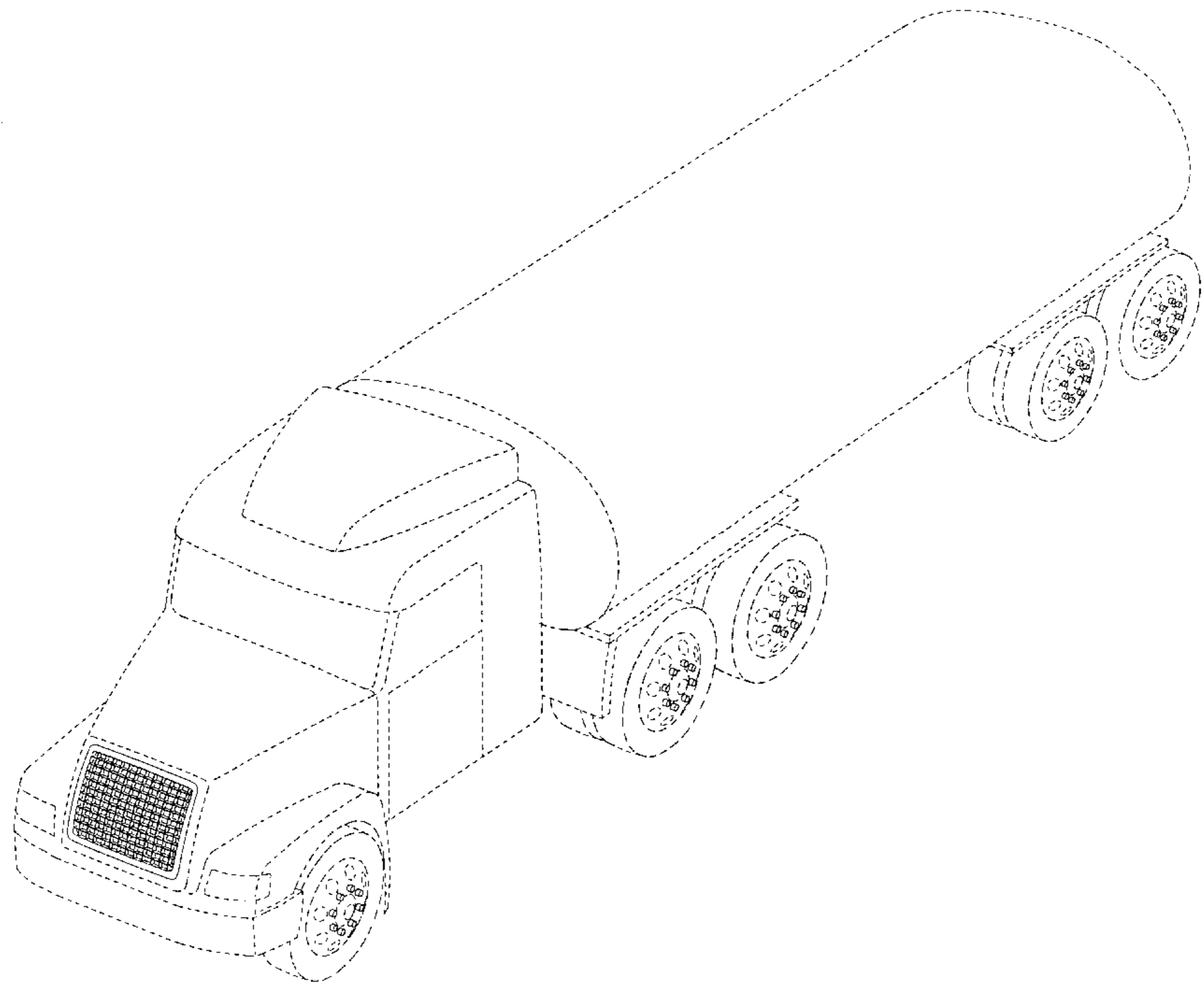

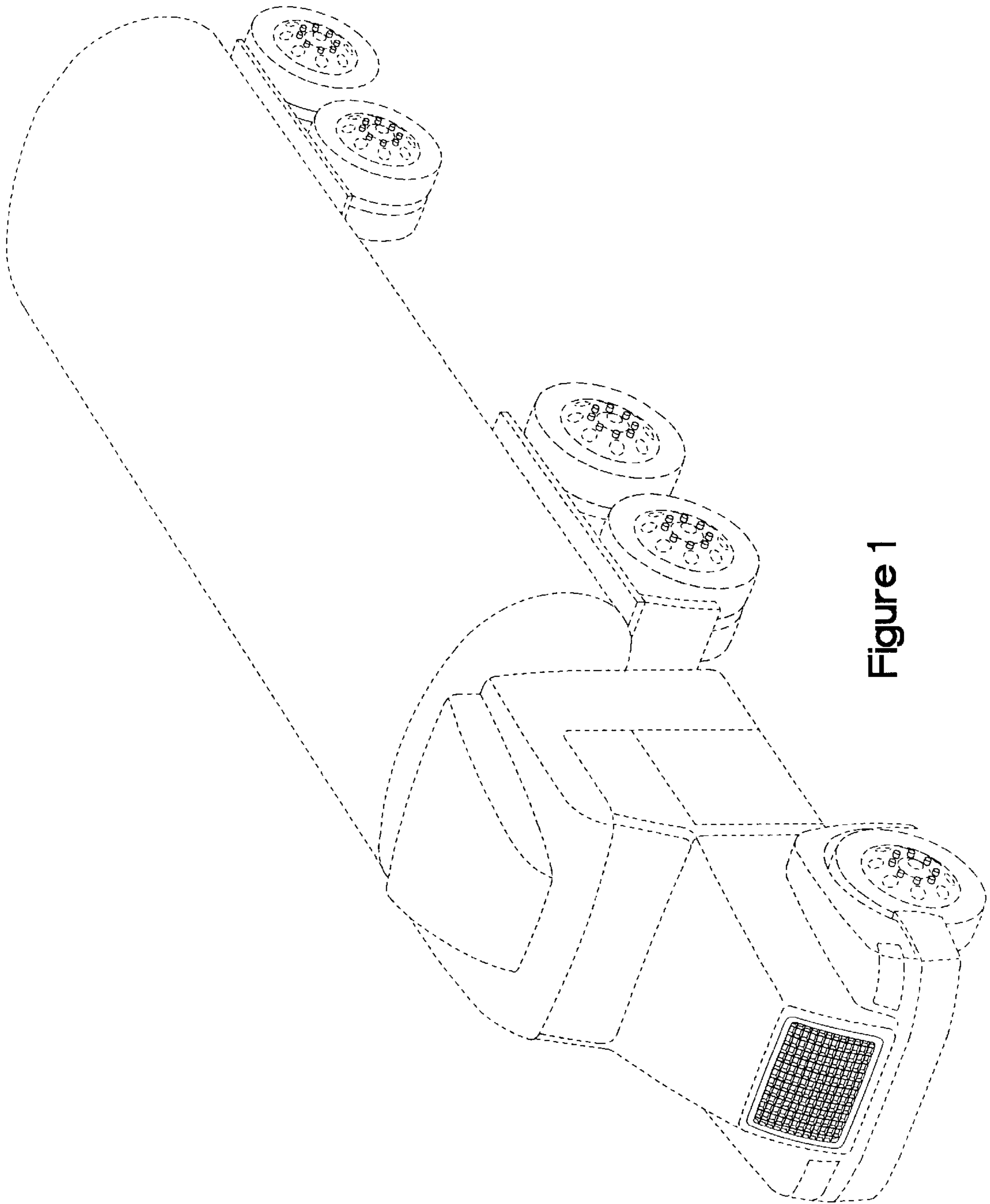

Figure 1

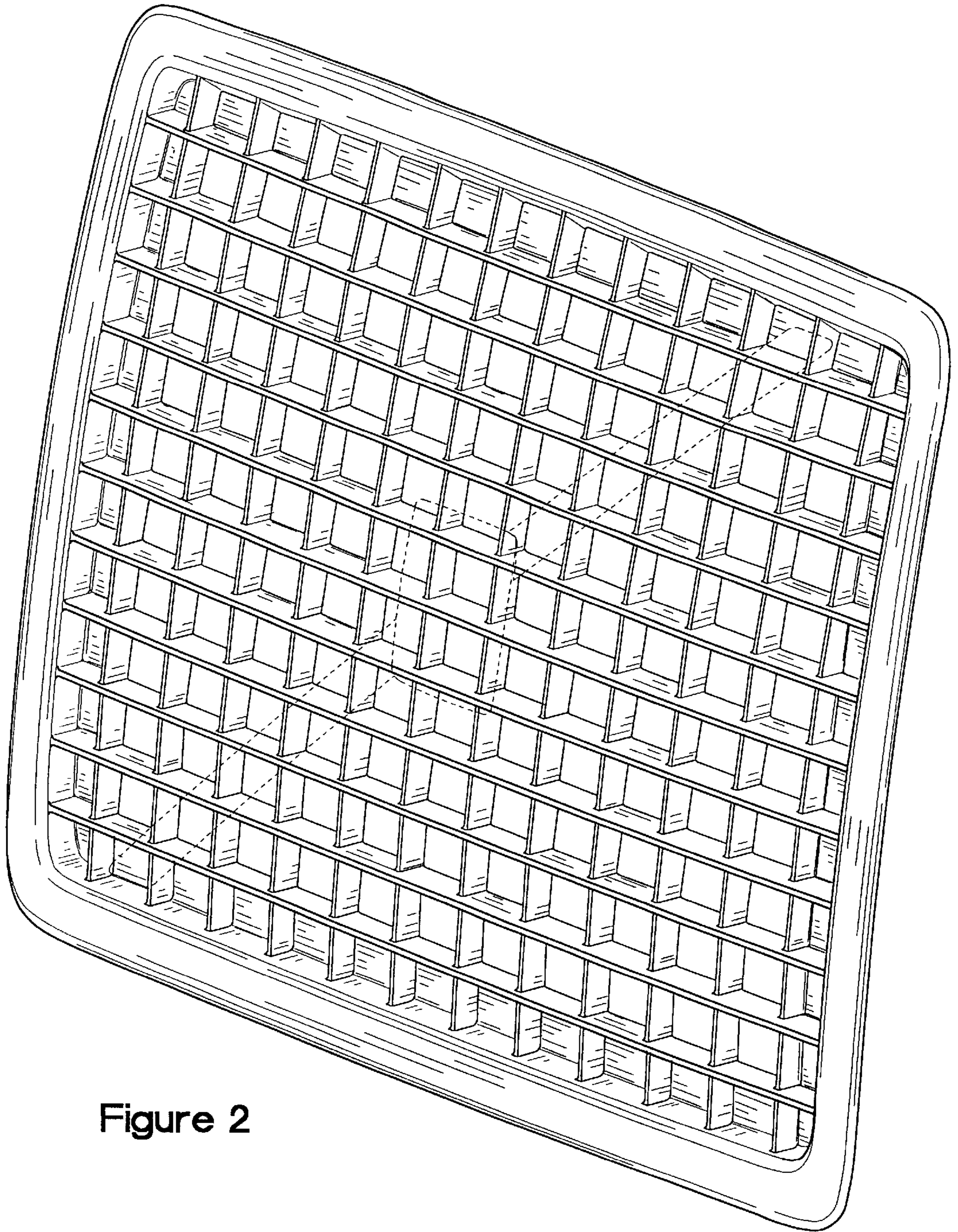

Figure 2

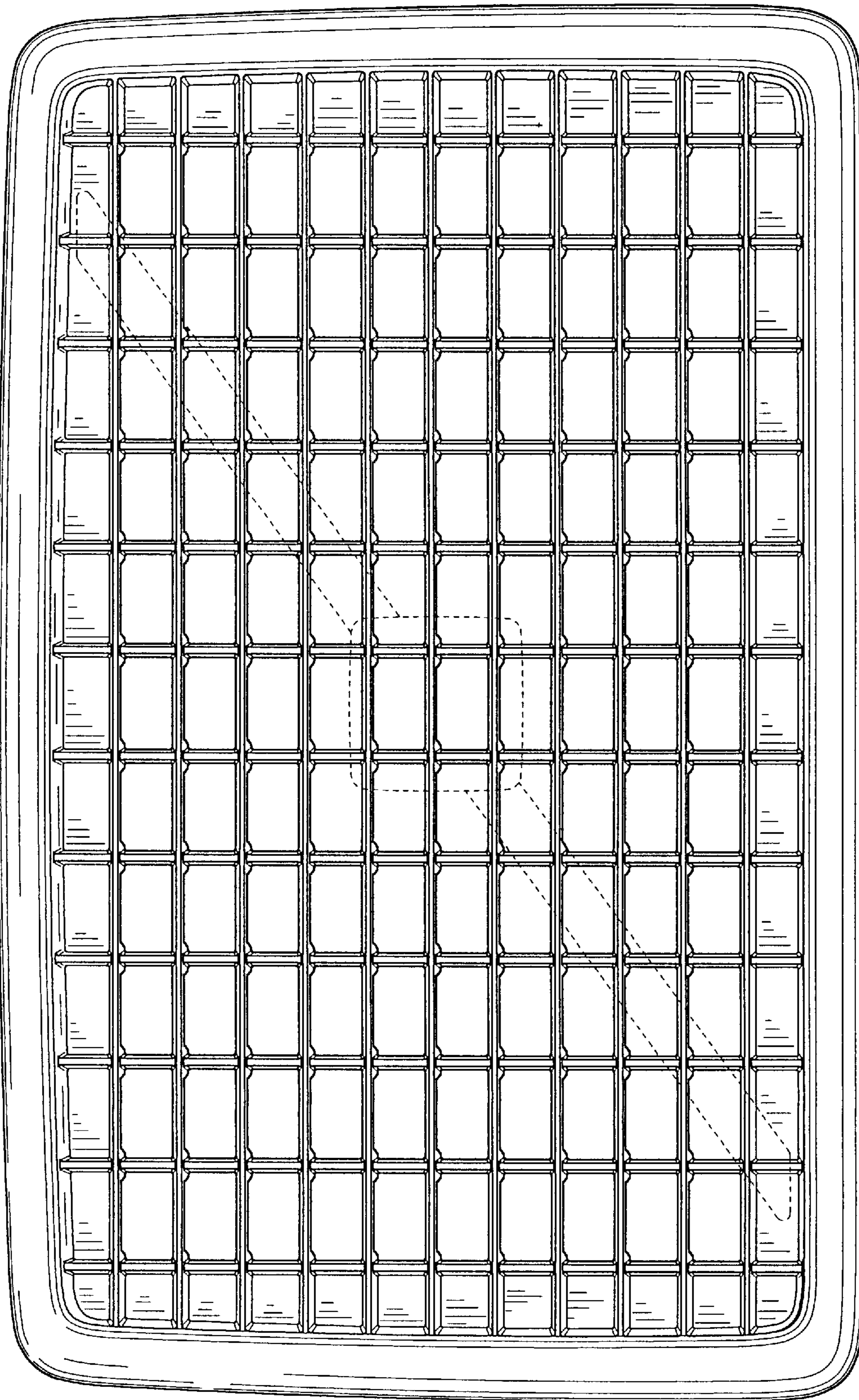

Figure 3

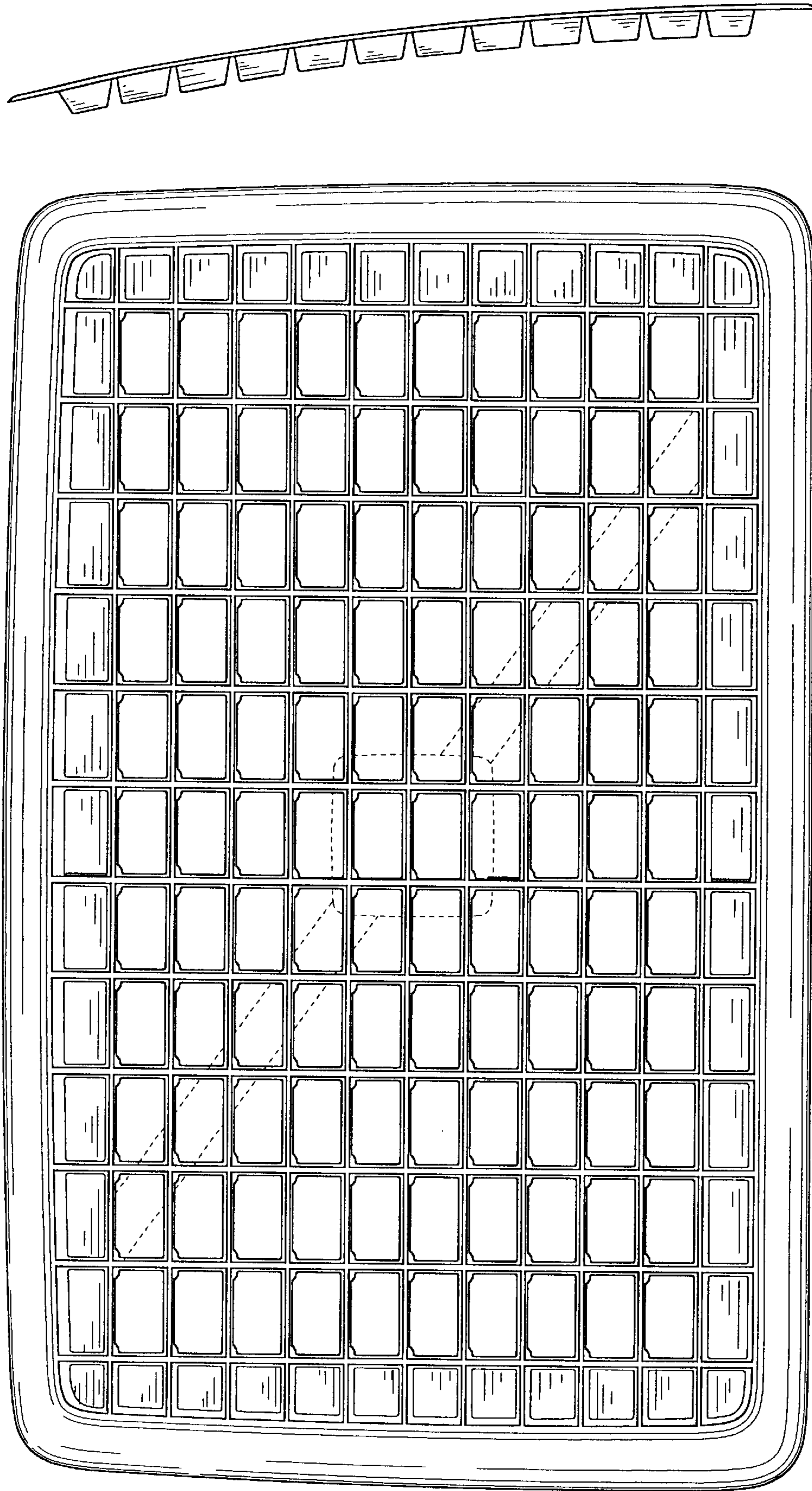

Figure 4

Figure 5

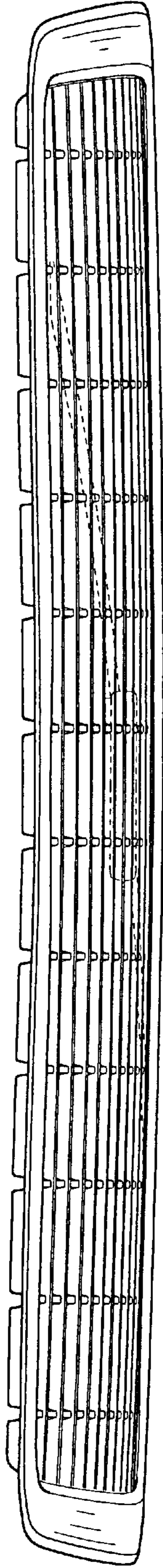

Figure 6

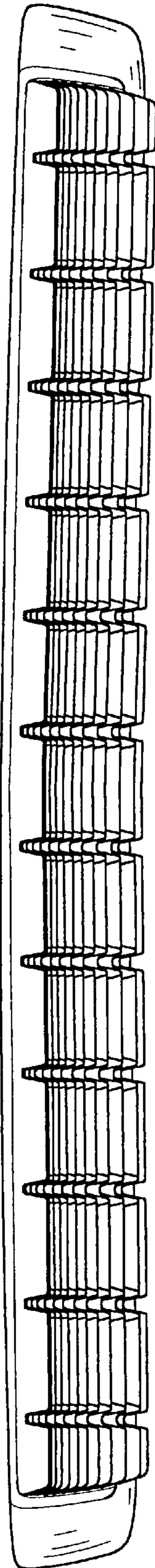

Figure 7

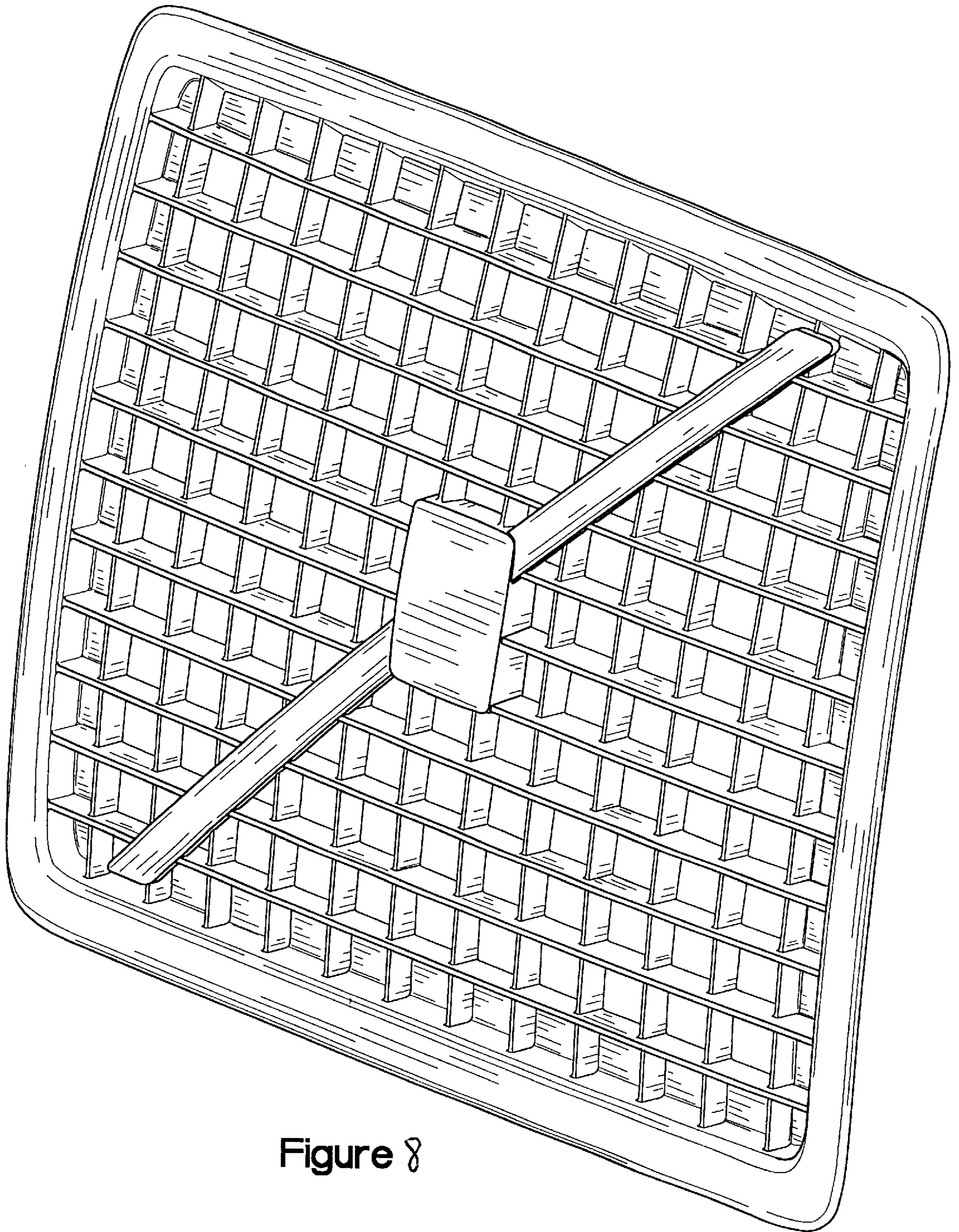

Figure 8

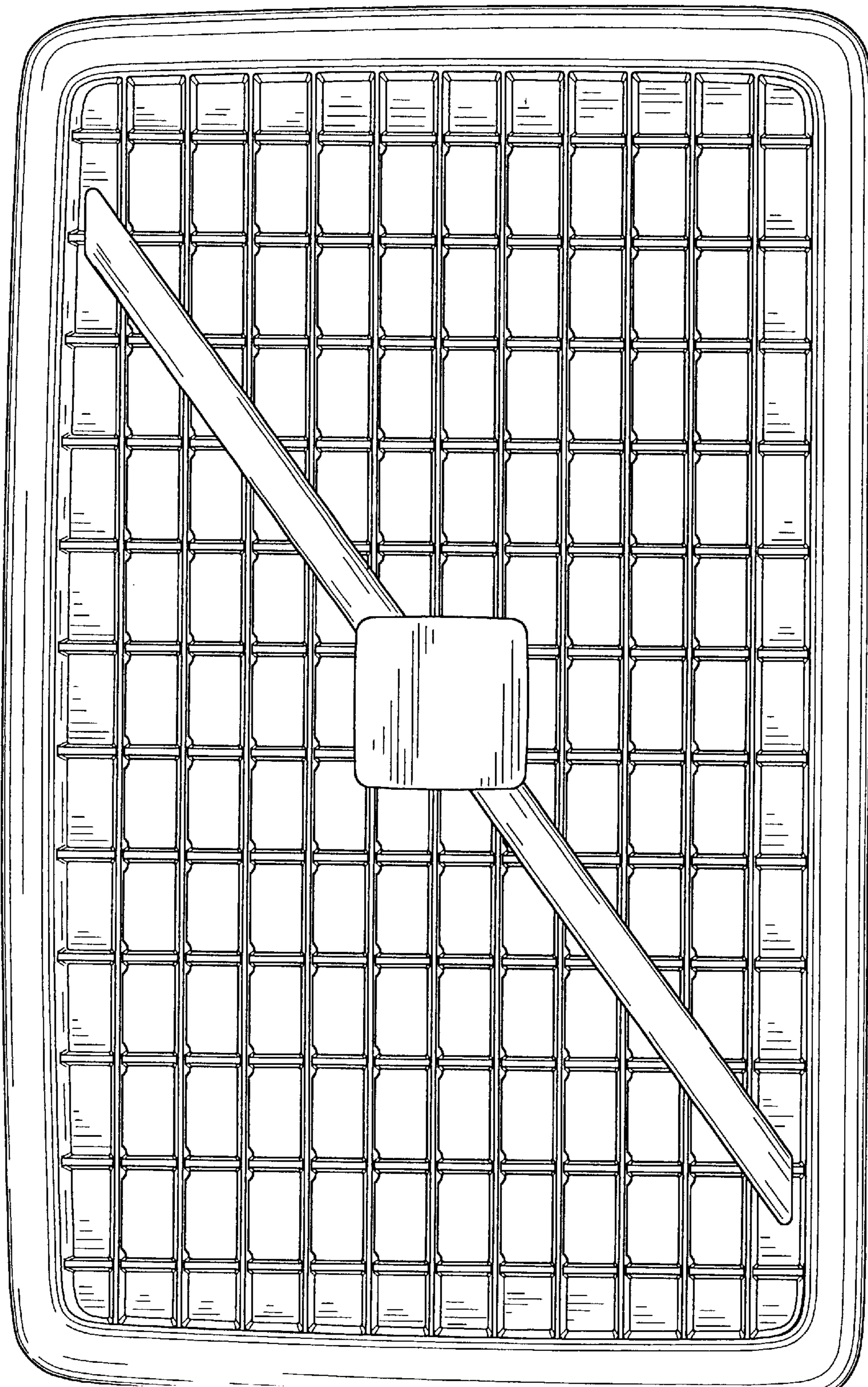

Figure 9

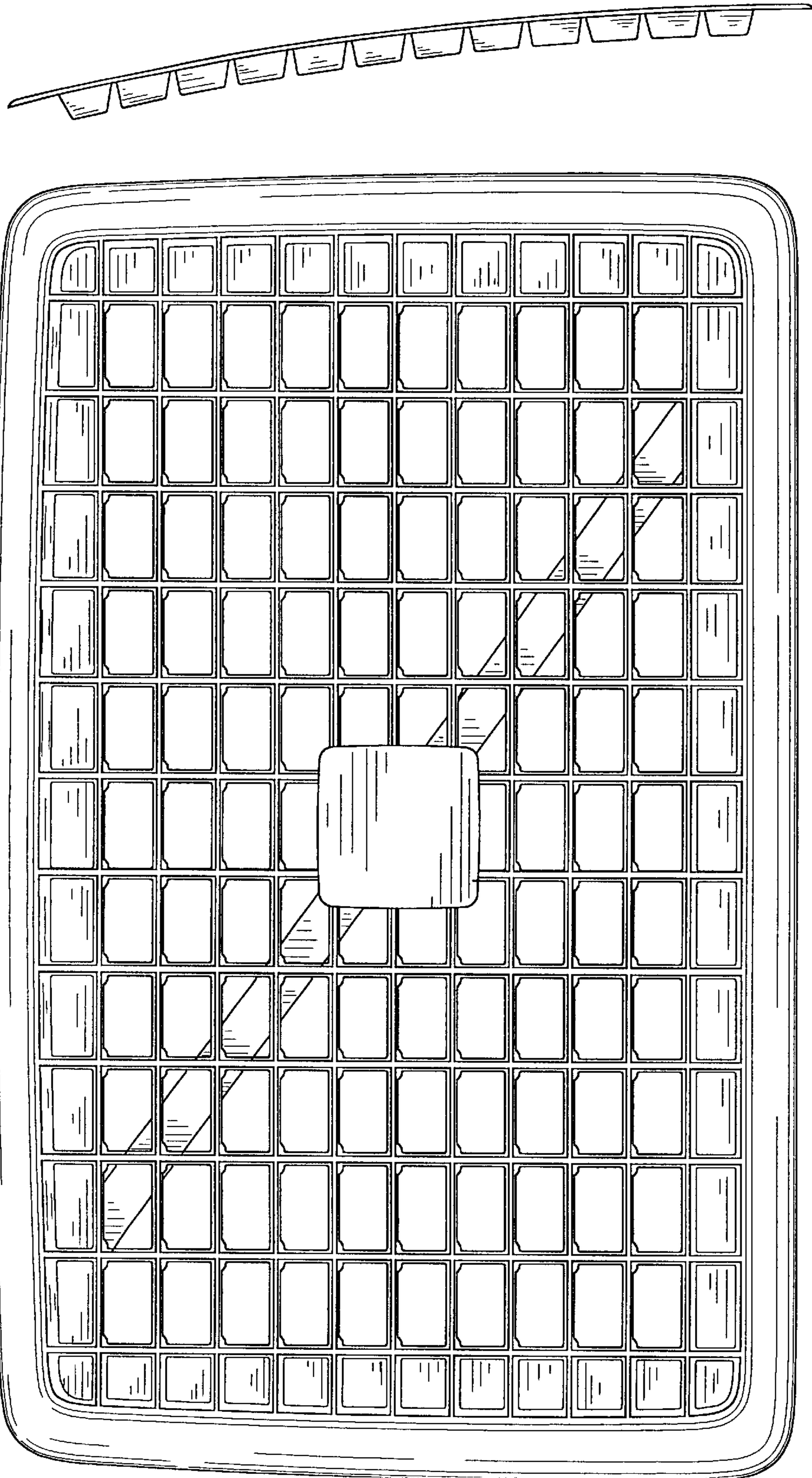

Figure 10

Figure 11

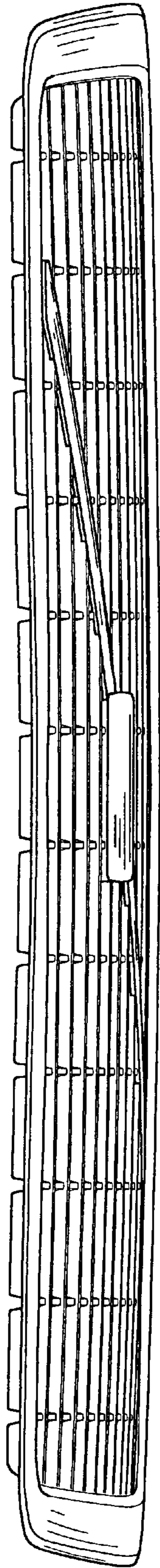

Figure 12

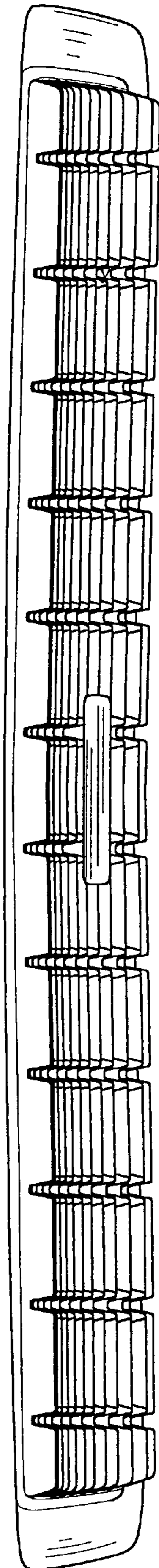

Figure 13