



US00D485847S

(12) **United States Design Patent**
Sanschagrın et al.

(10) **Patent No.:** **US D485,847 S**
(45) **Date of Patent:** **** Jan. 27, 2004**

- (54) **ELEMENT OF THE COWLING**
- (75) Inventors: **Stephane Sanschagrın**, St-Hyacinthe (CA); **Pierre Vignau**, Montreal (CA)
- (73) Assignee: **Bombardier Motor Corporation of America**, Grant, FL (US)
- (**) Term: **14 Years**

<http://www.evinrude.com/evinrude/web/jsp/mainPage.jsp?Params=N.US.200004.0>, Copyright 2001.
<http://www.johnson.com/Johnson/web/jsp/mainPage.jsp?Params=N.US.200008.0>, Copyright 2001.
<http://www.johnson.com/Johnson/web/jsp/mainPage.jsp?Params=N.US.200009.0>, Copyright 2001.
<http://www.johnson.com/Johnson/web/jsp/mainPage.jsp?Params=N.US.200001.0>, Copyright 2001.

(List continued on next page.)

- (21) Appl. No.: **29/183,423**
- (22) Filed: **Jun. 12, 2003**

Primary Examiner—Melody N. Brown
 (74) *Attorney, Agent, or Firm*—Pillsbury Winthrop LLP

Related U.S. Application Data

- (62) Division of application No. 29/175,384, filed on Feb. 4, 2003, which is a continuation of application No. 29/159,706, filed on Apr. 26, 2002, now Pat. No. Des. 474,784.
- (51) **LOC (7) Cl.** **12-16**
- (52) **U.S. Cl.** **D15/4**
- (58) **Field of Search** D15/1-5; 440/3-6, 440/52, 88; 123/495; 290/43-46, 54

(57) **CLAIM**

The ornamental design for an element of a cowling, as shown and described.

DESCRIPTION

(56) **References Cited**

U.S. PATENT DOCUMENTS

D412,911 S	8/1999	Iekura	
D418,519 S	1/2000	Iekura	
D422,599 S	4/2000	Iekura	
D428,616 S	7/2000	Iekura	
D453,772 S	* 2/2002	Burmeister et al. D15/4
D457,166 S	5/2002	Burmeister et al.	
D458,273 S	6/2002	Burmeister et al.	
D463,448 S	9/2002	Osumi et al.	
D474,784 S	* 5/2003	Sanschagrın et al. D15/4

FIG. 1 is a perspective view, from the rear, left side, of an element of a cowling of our design;
 FIG. 2 is a perspective view thereof, from the front, left side;
 FIG. 3 is a front view thereof;
 FIG. 4 is a rear view thereof;
 FIG. 5 is a left side view thereof, the right side view being a mirror image;
 FIG. 6 is a top view thereof;
 FIG. 7 is a perspective view from the rear, left side of an element of a cowling showing a second embodiment of our new design;
 FIG. 8 is a perspective view of the design of FIG. 7, from the front, left side;
 FIG. 9 is a front view of the design of FIG. 7;
 FIG. 10 is a rear view of the design of FIG. 7;
 FIG. 11 is a left side view of the design of FIG. 7, the right side view being a mirror image; and,
 FIG. 12 is a top view of the design of FIG. 7.

Where included, broken lines showing environment or structure are for illustrative purposes only and from no part of the claimed design.

<http://www.evinrude.com/evinrude/web/jsp/mainPage.jsp?Params=N.US.200001.0>, Copyright 2001.
<http://www.evinrude.com/evinrude/web/jsp/mainPage.jsp?Params=N.US.200002.0>, Copyright 2001.
<http://www.evinrude.com/evinrude/web/jsp/mainPage.jsp?Params=N.US.200003.0>, Copyright 2001.

1 Claim, 8 Drawing Sheets

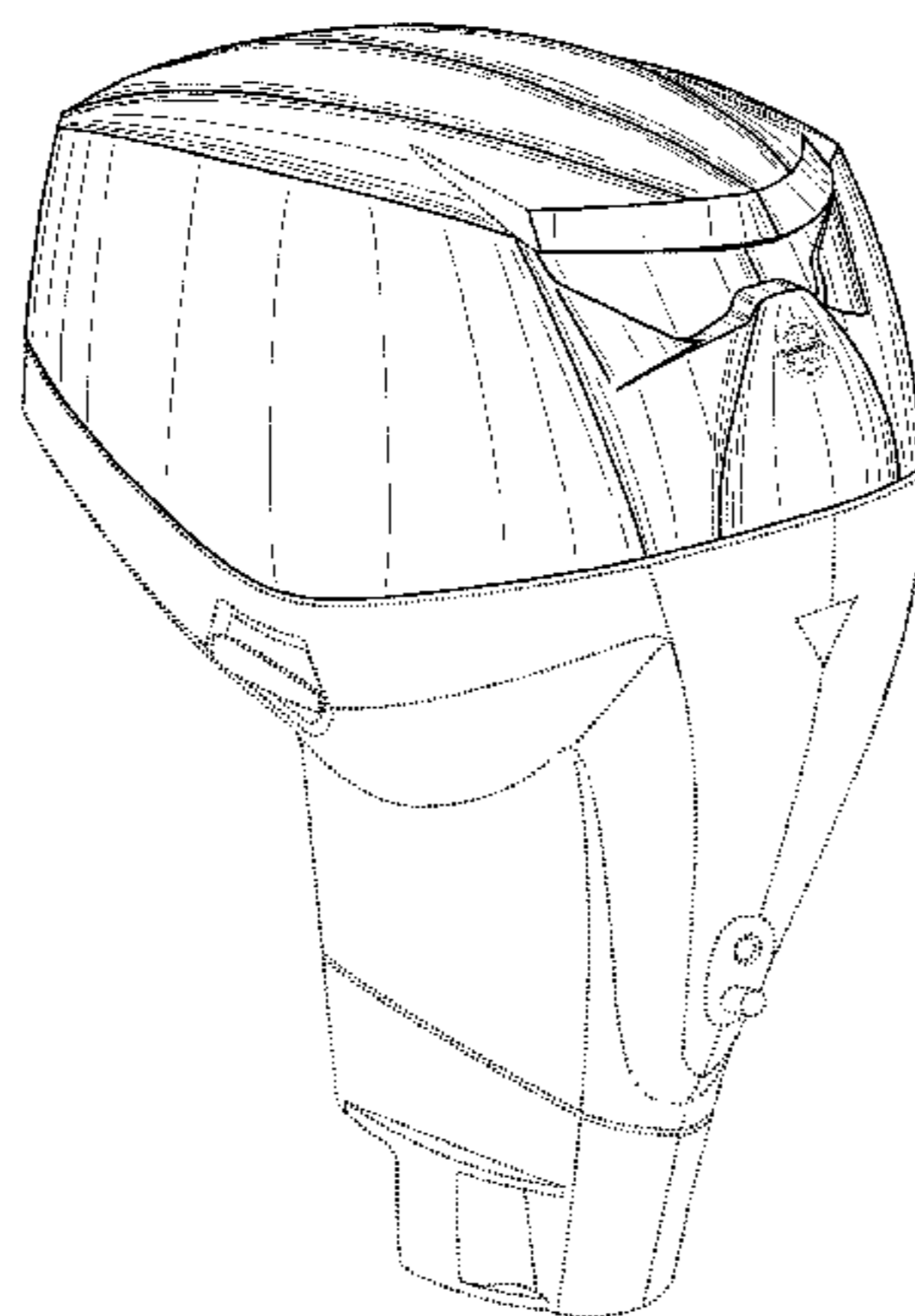

OTHER PUBLICATIONS

<http://www.johnson.com/Johnson/web/jsp/mainPage.jsp?Params=N.US.200002.0>, Copyright 2001.

<http://www.johnson.com/Johnson/web/jsp/mainPage.jsp?Params=N.US.200004.0>, Copyright 2001.

<http://www.johnson.com/Johnson/web/jsp/mainPage.jsp?Params=N.US.200005.0>, Copyright 2001.

<http://www.hondabf225.com/bf225.htm>, Copyright 2000.

<http://www.honda-marine.com/bf225.htm>, Copyright 2000.

<http://www.honda-marine.com/bf130.htm>, Copyright 2000.

<http://www.honda-marine.com/bf90.htm>, Copyright 2000.

<http://www.honda-marine.com/bf50.htm>, Copyright 2000.

<http://www.honda-marine.com/bf40.htm>, Copyright 2000.

<http://www.honda-marine.com/bf30.htm>, Copyright 2000.

<http://www.honda-marine.com/bf15.htm>, Copyright 2000.

<http://www.honda-marine.com/bf9.9.htm>, Copyright 2000.

<http://www.honda-marine.com/bf8.htm>, Copyright 2000.

<http://www.honda-marine.com/bf5.htm>, Copyright 2000.

<http://www.honda-marine.com/bf2.htm>, Copyright 2000.

http://www.mercurymarine.com/cgi-bin/mercprod/MercuryHome/Templates/DotComTemplate.jsp?BV__UseBV-Cookie=no&ParentID=null&page_id=643&ProdID=23306&Area=Saltwater%20OptiMax&BV__SessionID=@@@@0551736409.1035904509@@@@&BV__EngineID=hadcfhklffejbedcfececjf.0, Copyright 2002.

http://www.mercurymarine.com/cgi-bin/mercprod/MercuryHome/Templates/DotComTemplate.jsp?BV__UseBV-Cookie=no&ParentID=null&page_id=643&PreodID=23306&Area=Saltwater%20OptiMax&CurSpecPos=2&BV__SessionID=@@@@0551736409.1035904509@@@@&BV__EngineID=hadcfhklffejbedcfececjf.0, Copyright 2002.

http://www.mercurymarine.com/cgi-bin/mercprod/MercuryHome/Templates/DotComTemplate.jsp?BV__UseBV-Cookie=no&ParentID=null&page_id=643&ProdID=23306&Area=Saltwater%20OptiMax&CurSpecPos=3&BV__SessionID=@@@@0551736409.1035904509@@@@&BV__EngineID=hadcfhklffejbedcfececjf.0, Copyright 2002.

http://www.mercurymarine.com/cgi-bin/mercprod/MercuryHome/Templates/DotComTemplate.jsp?BV__UseBV-Cookie=no&ParentID=null&page_id=643&ProdID=23328&Area=Saltwater%20Carb&BV__SessionID=@@@@0551736409.1035904509@@@@&BV__EngineID=hadcfhklffejbedcfececjf.0, Copyright 2002.

http://www.mercurymarine.com/cgi-bin/mercprod/MercuryHome/Templates/DotComTemplate.jsp?BV__UseBV-Cookie=no&ParentID=null&page_id=643&ProdID=23328&Area=Saltwater%20Carb&CurSpecPos=2&BV__SessionID=@@@@0551736409.1035904509@@@@&BV__EngineID=hadcfhklffejbedcfececjf.0, Copyright 2002.

http://www.mercurymarine.com/cgi-bin/mercprod/MercuryHome/Templates/DotComTemplate.jsp?BV__UseBV-Cookie=no&ParentID=null&page_id=643&ProdID=23571&Area=Portable%20FourStroke&BV__SessionID=@@@@0551736409.1035904509@@@@&BV__EngineID=hadcfhklffejbedcfececjf.0, Copyright 2002.

http://www.mercurymarine.com/cgi-bin/mercprod/MercuryHome/Templates/DotComTemplate.jsp?BV__UseBV-Cookie=no&ParentID=null&page_id=643&ProdID=23571&Area=Portable%20FourStroke&CurSpecPos=1&BV__SessionID=@@@@0551736409.1035904509@@@@&BV__EngineID=hadcfhklffejbedcfececjf.0, Copyright 2002.

http://www.mercurymarine.com/cgi-bin/mercprod/MercuryHome/Templates/DotComTemplate.jsp?BV__UseBV-Cookie=no&ParentID=null&page_id=643&ProdID=23571&Area=Portable%20FourStroke&CurSpecPos=3&BV__SessionID=@@@@0551736409.1035904509@@@@&BV__EngineID=hadcfhklffejbedcfececjf.0, Copyright 2002.

http://www.mercurymarine.com/cgi-bin/mercprod/MercuryHome/Templates/DotComTemplate.jsp?BV__UseBV-Cookie=no&ParentID=null&page_id=643&ProdID=23570&Area=Big%20Foot%20FourStroke&BV__SessionID=@@@@0551736409.1035904509@@@@&BV__EngineID=hadcfhklffejbedcfececjf.0, Copyright 2002.

http://www.mercurymarine.com/cgi-bin/mercprod/MercuryHome/Templates/DotComTemplate.jsp?BV__UseBV-Cookie=no&ParentID=null&page_id=643&ProdID=23570&Area=Big%20Foot%20FourStroke&CurSpecpos=1&BV__SessionID=@@@@0551736409.1035904509@@@@&BV__EngineID=hadcfhklffejbedcfececjf.0, Copyright 2002.

http://www.mercurymarine.com/cgi-bin/mercprod/MercuryHome/Templates/DotComTemplate.jsp?BV__UseBV-Cookie=no&ParentID=null&page_id=643&ProdID=23570&Area=Big%20Foot%20FourStroke&CurSpecPos=3&BV__SessionID=@@@@0551736409.1035904509@@@@&BV__EngineID=hadcfhklffejbedcfececjf.0, Copyright 2002.

http://www.mercurymarine.com/cgi-bin/mercprod/MercuryHome/Templates/DotComTemplate.jsp?BV__UseBV-Cookie=no&ParentID=null&page_id=643&ProdID=23570&Area=Big%20Foot%20FourStroke&CurSpecPos=3&BV__SessionID=@@@@0551736409.1035904509@@@@&BV__EngineID=hadcfhklffejbedcfececjf.0, Copyright 2002.

http://www.mercurymarine.com/cgi-bin/mercprod/MercuryHome/Templates/DotComTemplate.jsp?BV__UseBV-Cookie=no&ParentID=null&page_id=643&ProdID=23570&Area=Big%20Foot%20FourStroke&CurSpecPos=4&BV__SessionID=@@@@0551736409.1035904509@@@@&BV__EngineID=hadcfhklffejbedcfececjf.0, Copyright 2002.

http://www.mercurymarine.com/cgi-bin/mercprod/MercuryHome/Templates/DotComTemplate.jsp?BV__UseBV-Cookie=no&ParentID=218&page_id=643&ProdID=23194&Area=V-6%20EFI&BV__SessionID=@@@@0551736409.1035904509@@@@&BV__EngineID=hadcfhklffejbedcfececjf.0, Copyright 2002.

http://www.mercurymarine.com/cgi-bin/mercprod/MercuryHome/Templates/DotComTemplate.jsp?BV__UseBV-Cookie=no&ParentID=null&page_id=643&ProdID=23194&Area=V-6%20EFI&CurspecPos=4&BV__SessionID=@@@@0551736409.1035904509@@@@&BV__EngineID=hadcfhklffejbedcfececjf.0, Copyright 2002.

http://www.mercurymarine.com/cgi-bin/mercprod/MercuryHome/Templates/DotComTemplate.jsp?BV__UseBV-Cookie=no&ParentID=null&page__id=643&PreodID=23210&Area=30%20-%20125%20hp&CurSpecPos=4&BV__SessionID=@@@@0551736409.1035904509@@@@&BV__EngineID=hadcfhklffejbedcfececfj.0, Copyright 2002.

http://www.mercurymarine.com/cgi-bin/mercprod/MercuryHome/Templates/DotComTemplate.jsp?BV__UseBV-Cookie=no&ParentID=218&page__id=643&PreodID=23246&Area=6%20-%2025%20hp&BV__SessionID=@@@@0551736409.1035904509@@@@&BV__EngineID=hadcfhklffejbedcfececfj.0, Copyright 2002.

http://www.mercurymarine.com/cgi-bin/mercprod/MercuryHome/Templates/DotComTemplate.jsp?BV__UseBV-Cookie=no&ParentID=null&page__id=643&ProdID=23246&Area=6%20-%2025%20hp&CurSpecPos=4&BV__SessionID=@@@@0551736409.1035904509@@@@&BV__EngineID=hadcfhklffejbedcfececfj.0, Copyright 2002.

http://www.mercurymarine.com/cgi-bin/mercprod/MercuryHome/Templates/DotComTemplate.jsp?BV__UseBV-Cookie=no&ParentID=218&page__id=643&ProdID=23259&Area=2.5%20-%205%20hp&BV__SessionID=@@@@0551736409.1035904509@@@@&BV__EngineID=hadcfhklffejbedcfececfj.0, Copyright 2002.

http://www.mercurymarine.com/cgi-bin/mercprod/MercuryHome/Templates/DotComTemplate.jsp?BV__UseBV-Cookie=no&ParentID=null&page__id=643&PerodID=23259&Area=2.5%20-%205%20hp&CurSpecPos=2&BV__SessionID=@@@@0551736409.1035904509@@@@&BV__EngineID=hadcfhklffejbedcfececfj.0, Copyright 2002.

http://www.mercurymarine.com/cgi-bin/mercprod/MercuryHome/Templates/DotComTemplate.jsp?BV__UseBV-Cookie=no&ParentID=null&page__id=643&ProdID=23569&Area=Mid-Range%20FourStroke&BV__SessionID=@@@@0551736409.1035904509@@@@&BV__EngineID=hadcfhklffejbedcfececfj.0, Copyright 2002.

http://www.mercurymarine.com/cgi-bin/mercprod/MercuryHome/Templates/DotComTemplate.jsp?BV__UseBV-Cookie=no&ParentID=null&page__id=643&ProdID=23569&Area=Mid-Range%20FourStroke&CurSpecPos=6&BV__SessionID=@@@@0551736409.1035904509@@@@&BV__EngineID=hadcfhklffejbedcfececfj.0, Copyright 2002.

http://www.mercurymarine.com/cgi-bin/mercprod/MercuryHome/Templates/DotComTemplate.jsp?BV__UseBV-Cookie=no&ParentID=218&page__id=643&ProdID=23259&Area=2.5%20-%205%20hp&BV__SessionID=@@@@0551736409.1035904509@@@@&BV__EngineID=hadcfhklffejbedcfececfj.0, Copyright 2002.

http://www.mercurymarine.com/cgi-bin/mercprod/MercuryHome/Templates/DotComTemplate.jsp?BV__UseBV-Cookie=no&ParentID=null&page__id=643&ProdID=23259&Area=2.5%20-%205%20hp&CurSpecPos=2&BV__SessionID=@@@@0551736409.1035904509@@@@&BV__EngineID=hadcfhklffejbedcfececfj.0, Copyright 2002.

http://www.mercurymarine.com/cgi-bin/mercprod/MercuryHome/Templates/DotComTemplate.jsp?BV__UseBV-Cookie=no&ParentID=null&page__id=648&ProdID=23685&Area=Performance%20Outboards&CurSpecPos=4&BV__SessionID=@@@@0551736409.1035904509@@@@&BV__EngineID=hadcfhklffejbedcfececfj.0, Copyright 2002.

http://www.mercurymarine.com/cgi-bin/mercprod/MercuryHome/Templates/DotComTemplate.jsp?BV__UseBV-Cookie=no&ParentID=202&page__id=648&ProdID=23705&Area=Race%20Outboards&BV__SessionID=@@@@0551736409.1035904509@@@@&BV__EngineID=hadcfhklffejbedcfececfj.0, Copyright 2002.

http://www.mercurymarine.com/cgi-bin/mercprod/MercuryHome/Templates/DotComTemplate.jsp?BV__UseBV-Cookie=no&ParentID=null&page__id=648&ProdID=23705&Area=Race%20Outboards&CurSpecPos=1&BV__SessionID=@@@@0551736409.1035904509@@@@&BV__EngineID=hadcfhklffejbedcfececfj.0, Copyright 2002.

<http://www.yamaha-motor.com/products/subcatinfo.asp?lid=5&1c=otb&cid=19&scid=1&year=2003&cat=Four+Stroke+Series&scat=High+Power>, Copyright 1996-2002.

<http://www.yamaha-motor.com/products/subcatinfo.asp?lid=5&1c=otb&cid=19&scid=2&year=2003&cat=Four+Stroke+Series&scat=Midrange>, Copyright 1996-2002.

<http://www.yamaha-motor.com/products/subcatinfo.asp?lid=5&1c=otb&cid=19&scid=3&year=2003&cat=Four+Stroke+Series&scat=Jet+Drive>, Copyright 1996-2002.

<http://www.yamaha-motor.com/products/subcatinfo.asp?lid=5&1c=otb&cid=19&scid=4&year=2003&cat=Four+Stroke+Series&scat=High+Thrust>, Copyright 1996-2002.

<http://www.yamaha-motor.com/products/subcatinfo.asp?lid=5&1c=otb&cid=19&scid=5&year=2003&cat=Four+Stroke+Series&scat=Portable>, Copyright 1996-2002.

<http://www.yamaha-motor.com/products/subcatinfo.asp?lid=5&1c=otb&cid=19&scid=11&year=2003&cat=HPDI+Series>, Copyright 1996-2002.

<http://www.yamaha-motor.com/products/subcatinfo.asp?lid=5&1c=otb&cid=18&scid=7&year=2003&cat=V+MAX+Series&scat=HPDI>, Copyright 1996-2002.

<http://www.yamaha-motor.com/products/subcatinfo.asp?lid=5&1c=otb&cid=18&scid=6&year=2003&cat=V+MAX+Series&scat=3%2E1L+Big+Block>, Copyright 1996-2002.

<http://www.yamaha-motor.com/products/subcatinfo.asp?lid=5&1c=otb&cid=18&scid=8&year=2003&cat=V+MAX+Series&scat=2%2E6L+OX66+%2F+Carb>, Copyright 1996-2002.

<http://www.yamaha-motor.com/products/subcatinfo.asp?lid=5&1c=otb&cid=20&scid=12&year=2003&cat=Two+Stroke+Series&scat=OX66+Saltwater+Series+II>, Copyright 1996-2002.

<http://www.yamaha-motor.com/products/subcatinfo.asp?lid=5&1c=otb&cid=20&scid=9&year=2003&cat=Two+Stroke+Series&scat=High+Power>, Copyright 1996-2002.

<http://www.yamaha-motor.com/products/subcatinfo.asp?lid=5&1c=otb&cid=20&scid=10&year=2003&cat=Two+Stroke+Series&scat=Midrange>, Copyright 1996-2002.

<http://www.yamaha-motor.com/products/subcatinfo.asp?lid=5&1c=otb&cid=20&scid=11&year=2003&cat=Two+Stroke+Series&scat=Portable>, Copyright 1996-2002.

<http://www.suzukimarine.com/4strokes/index.html>, Copyright 1996-2002.

<http://www.suzukimarine.com/2strokes/index.html>, Copyright 1996–2002.

<http://www.suzukimarine.com/sr00/info/frshore.htm>, Copyright 1996–2000.

<http://www.suzukimarine.com/sr00/info/mid.htm>, Copyright 1996–2000.

<http://www.suzukimarine.com/sr00/info/mid4s.htm>, Copyright 1996–2000.

<http://www.suzukimarine.com/sr00/info/port.htm>, Copyright 1996–2000.

<http://www.suzukimarine.com/sr00/info/frperf.htm>, Copyright 1996–2000.

<http://www.suzukimarine.com/sr97/comp.htm>, Copyright 1996/97.

<http://www.suzukimarine.com/sr97/port.htm>, Copyright 1996/97.

<http://www.suzukimarine.com/sr97/frstrok.htm>, Copyright 1996/97.

* cited by examiner

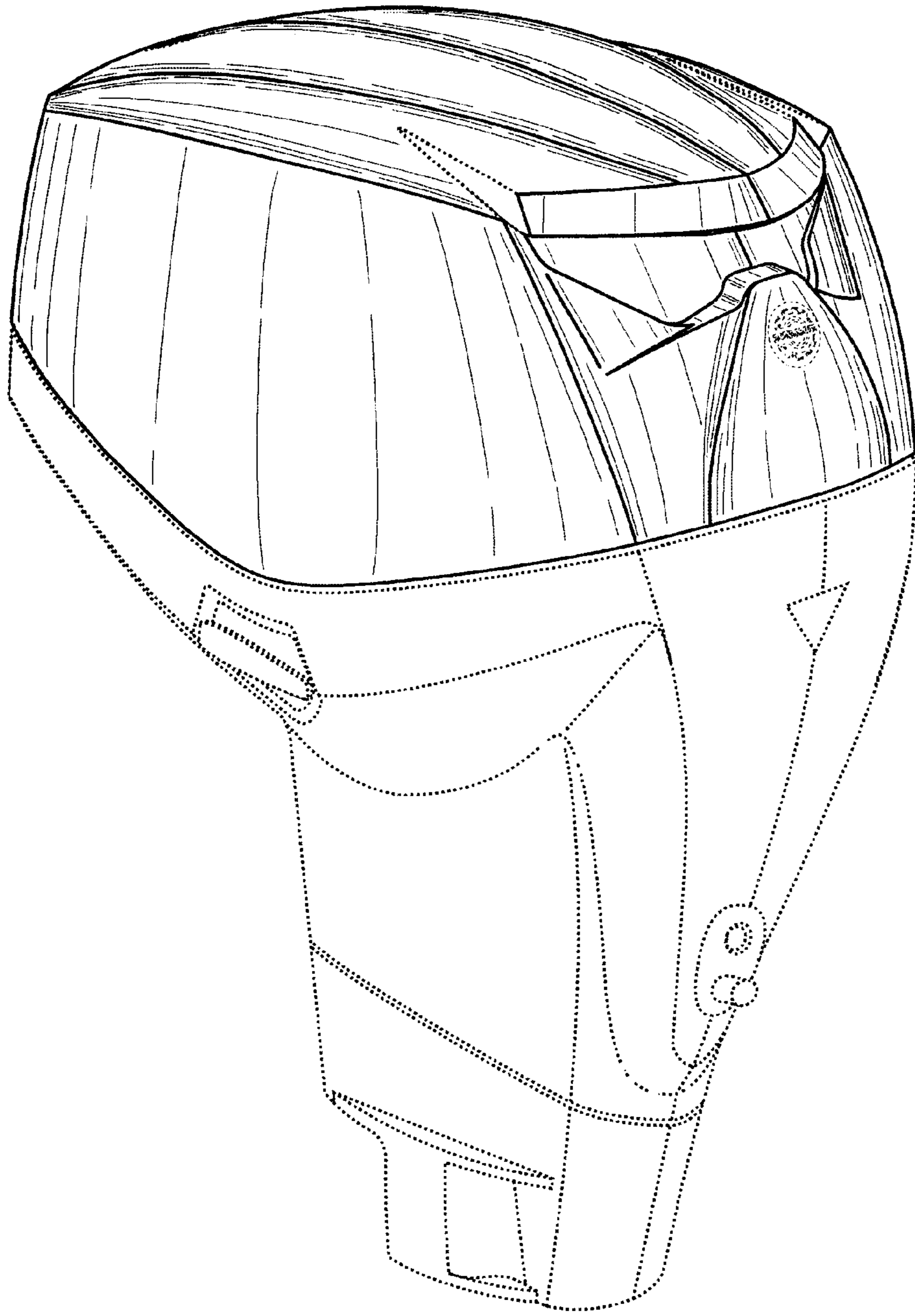

FIG. 1

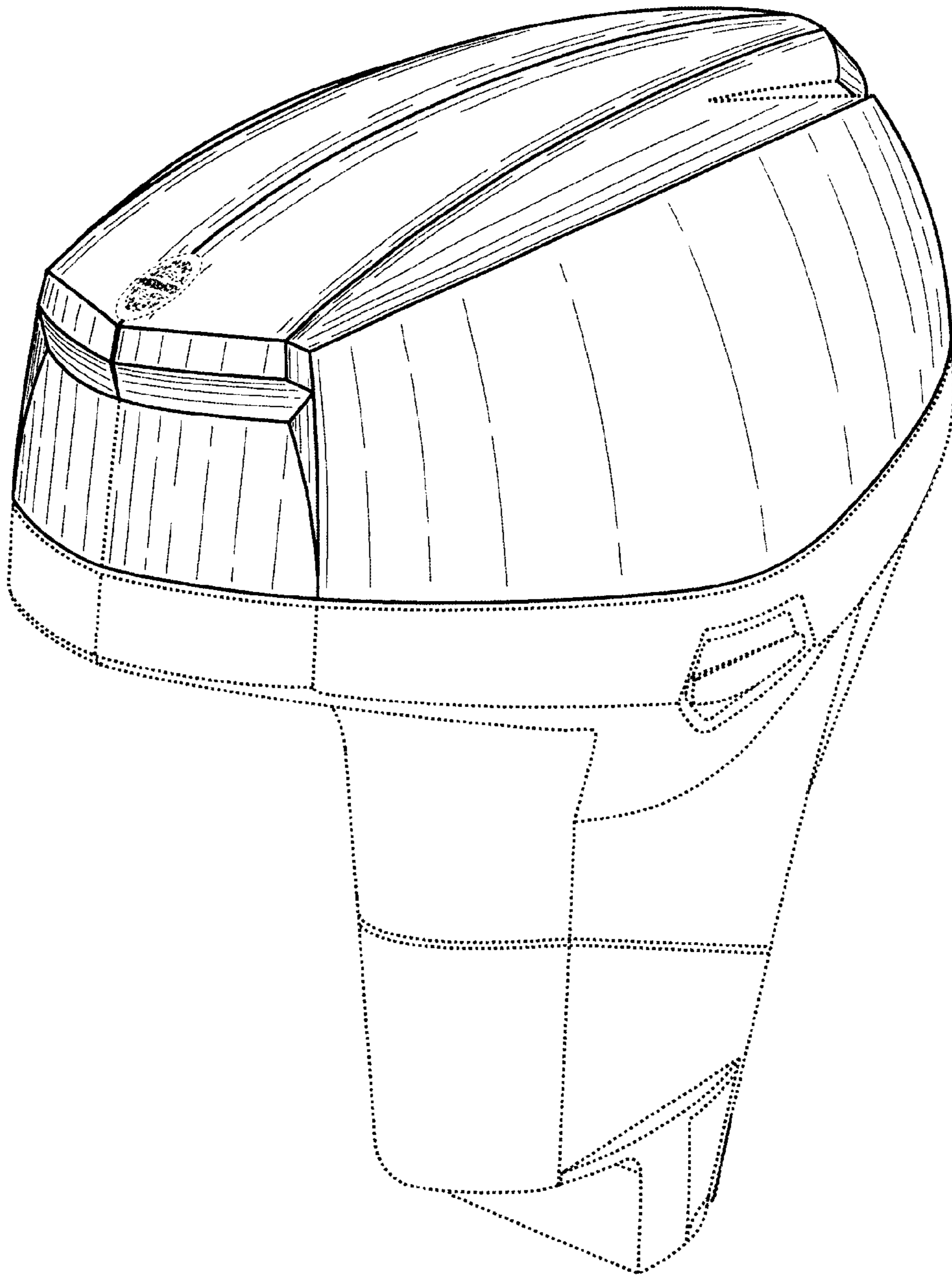

FIG. 2

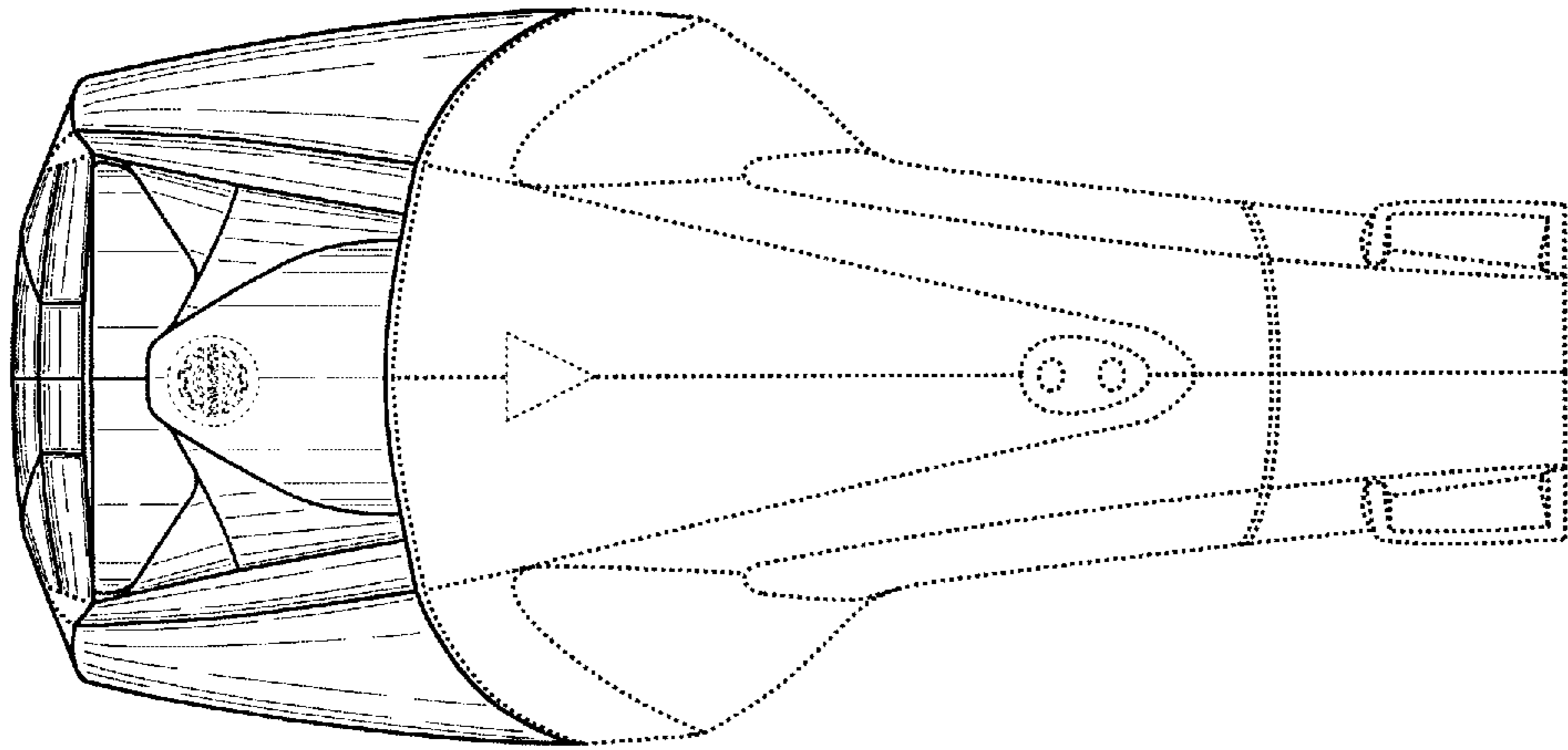

FIG. 3

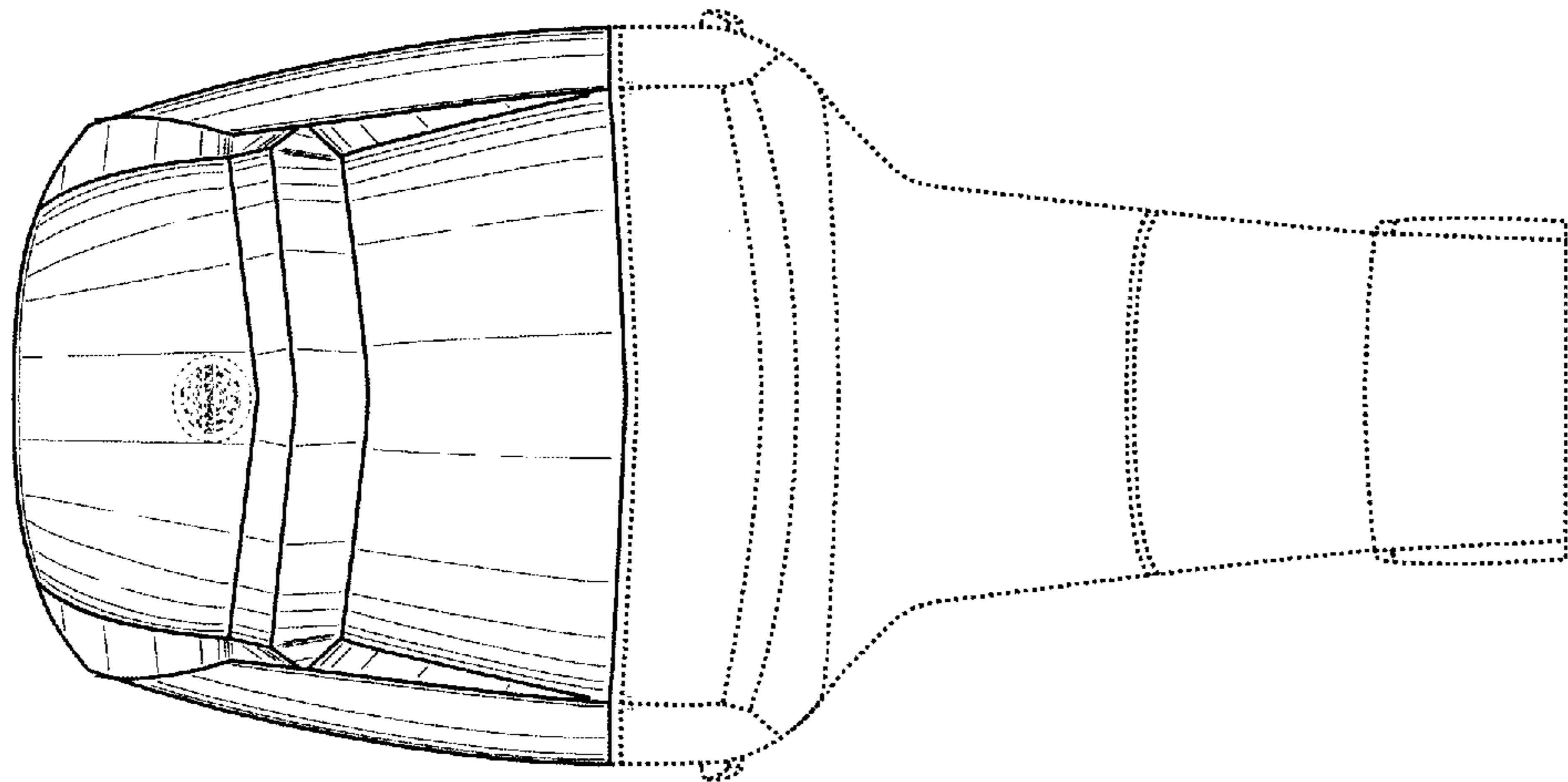

FIG. 4

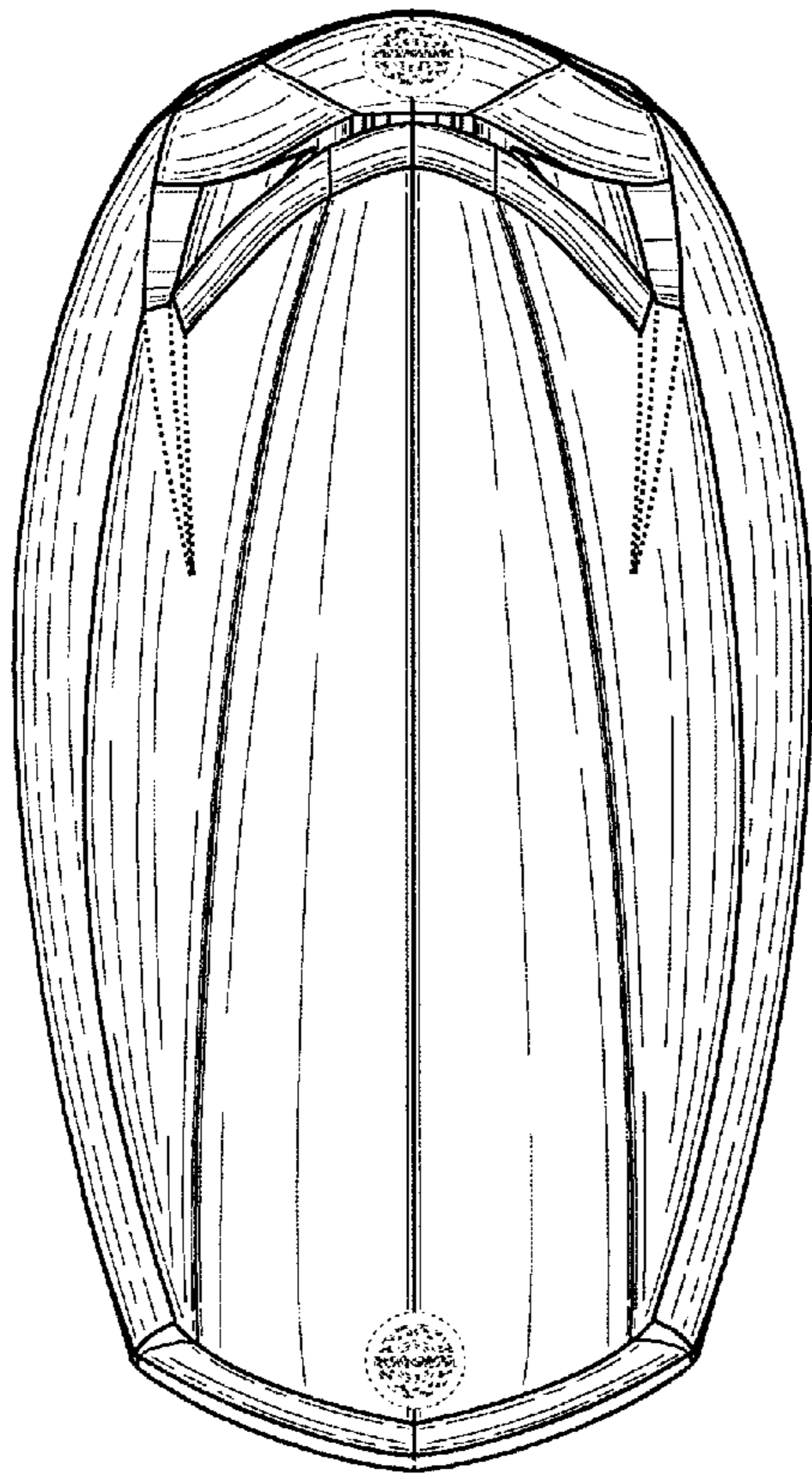

FIG. 6

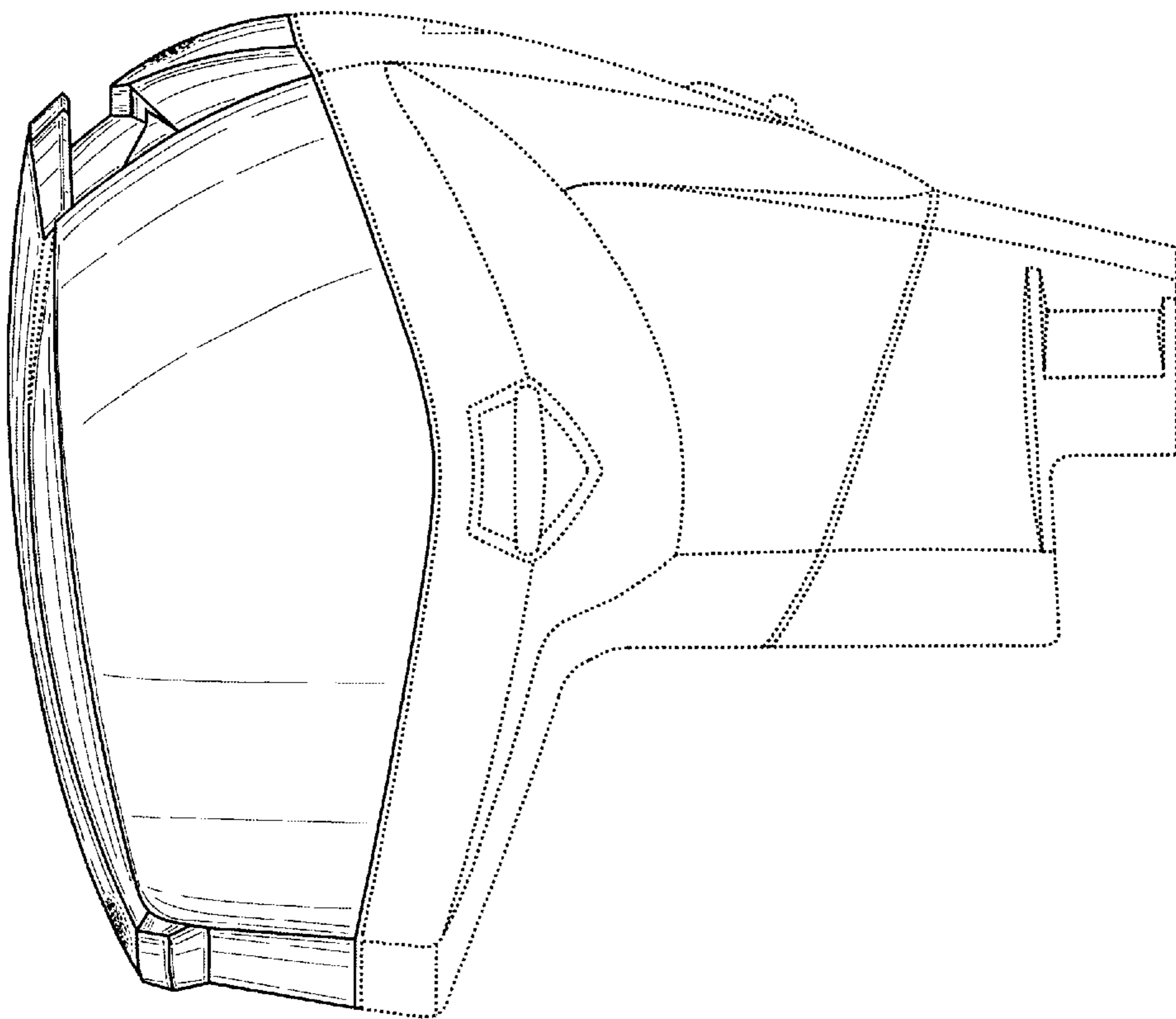

FIG. 5

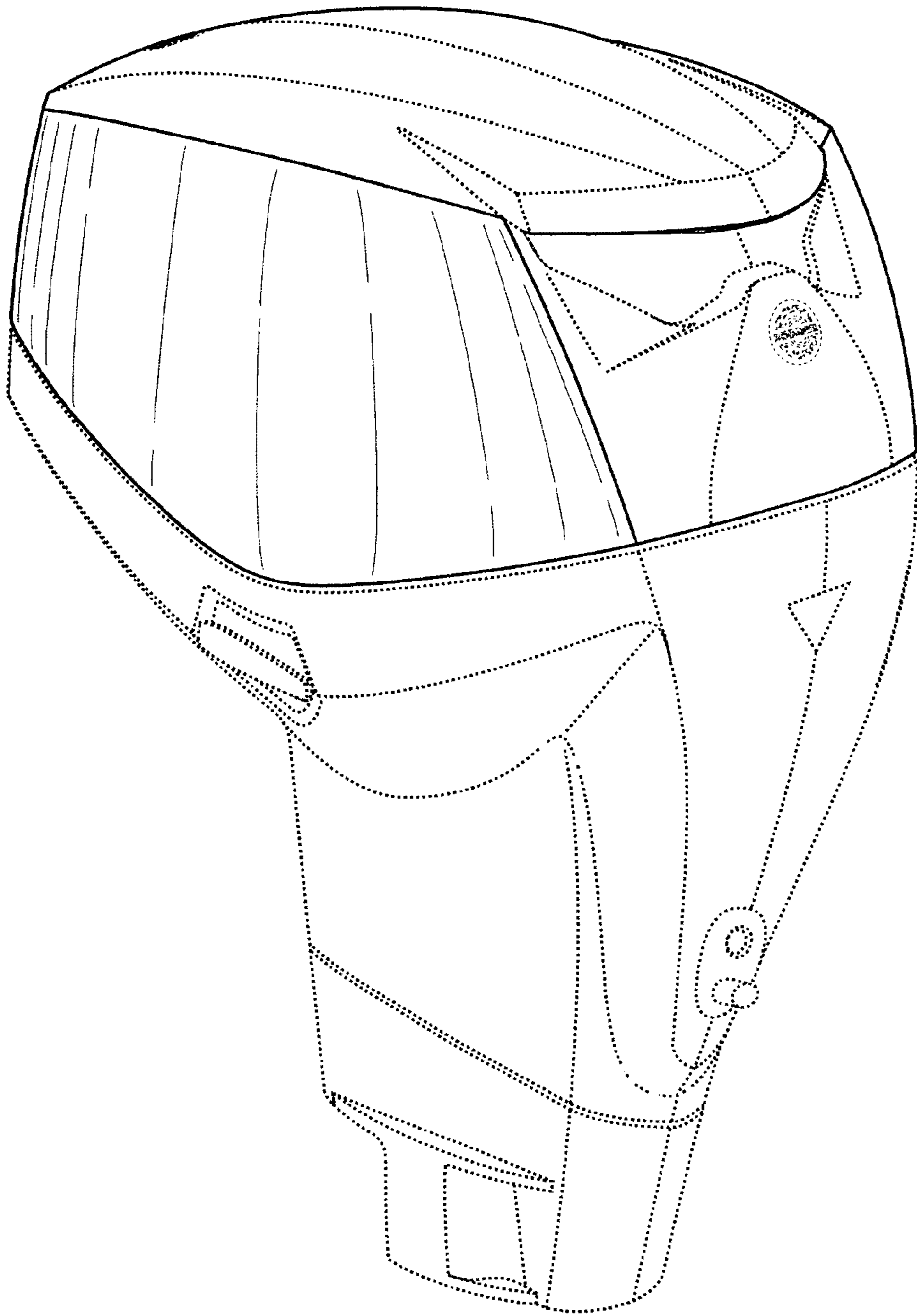

FIG. 7

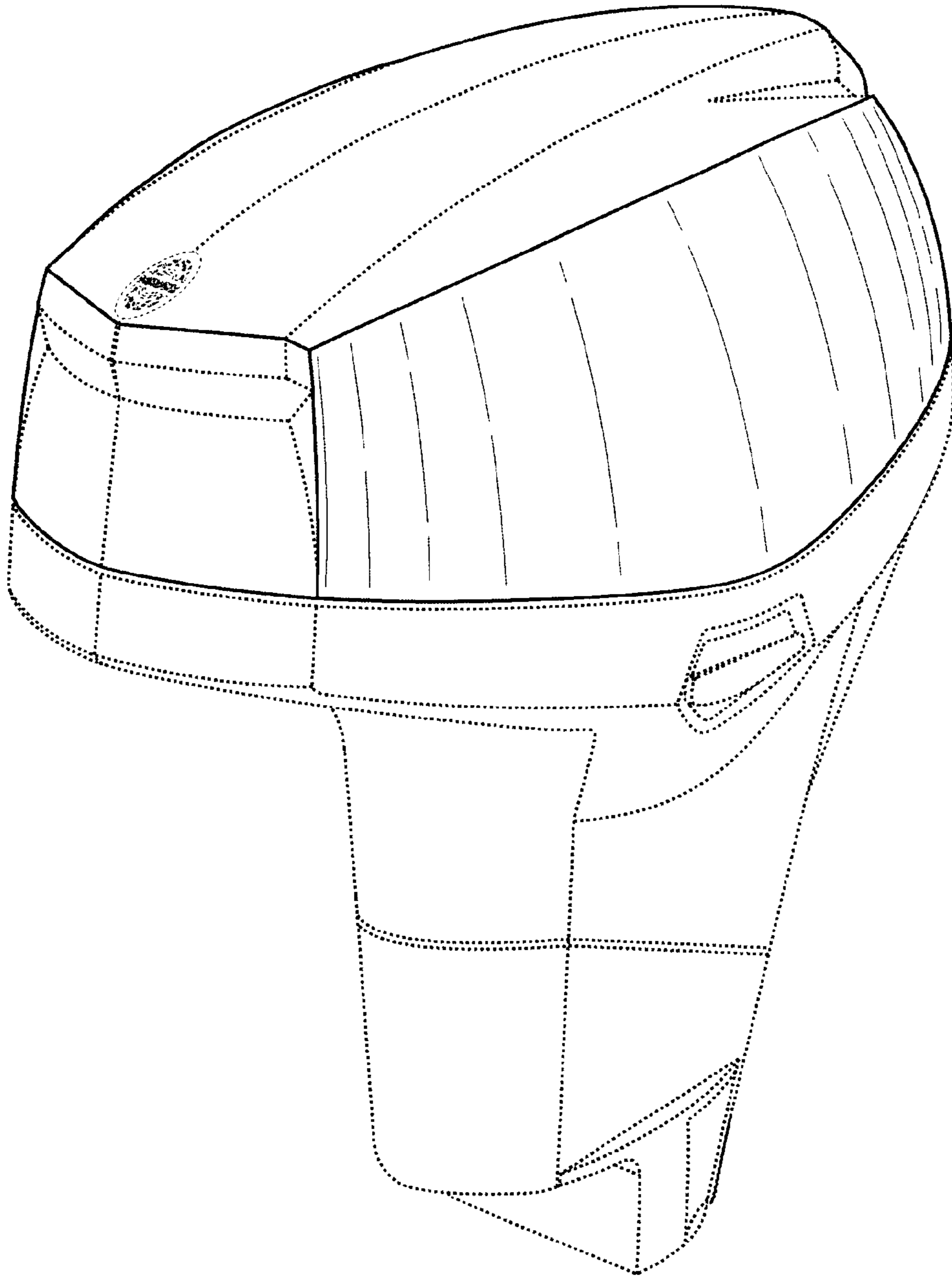

FIG. 8

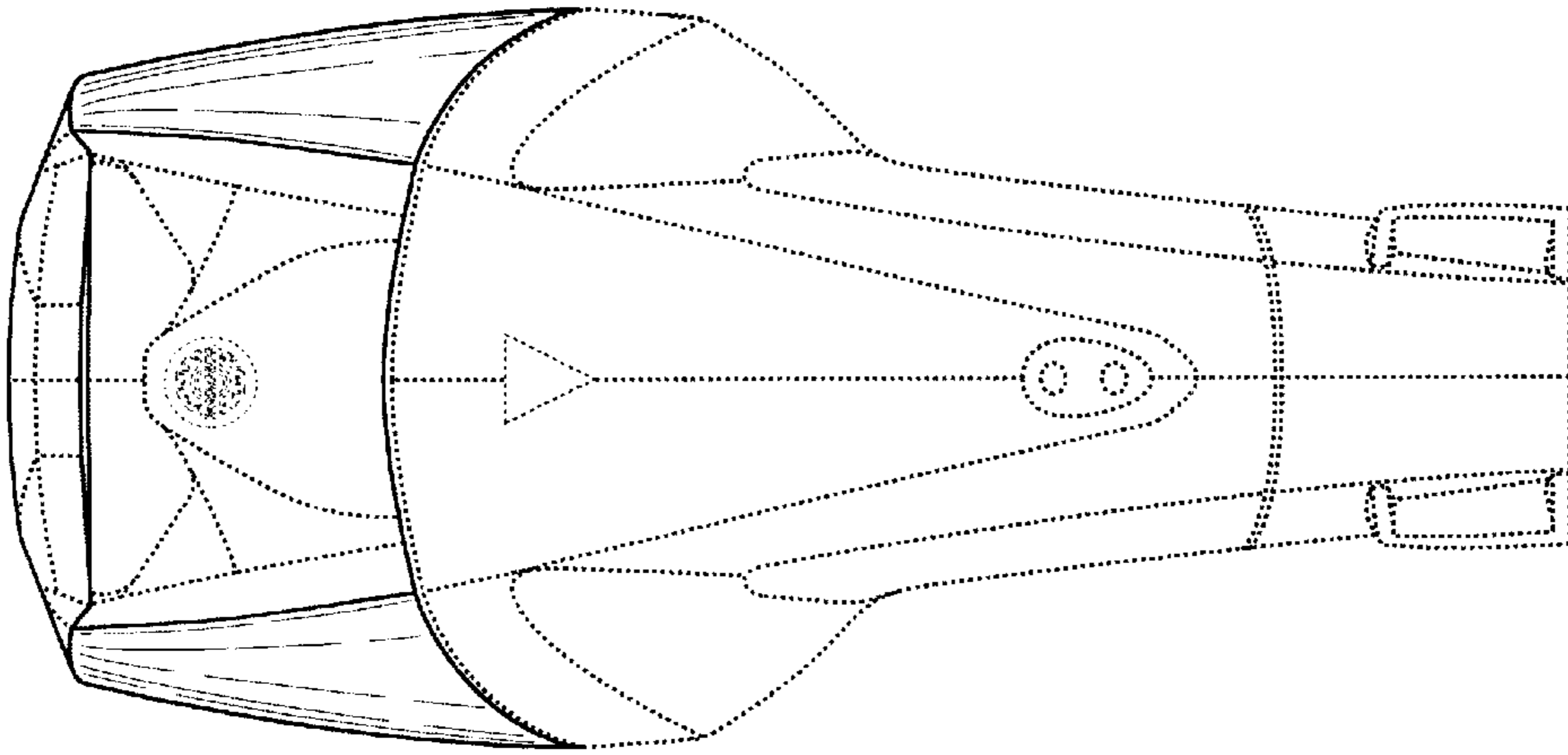

FIG. 9

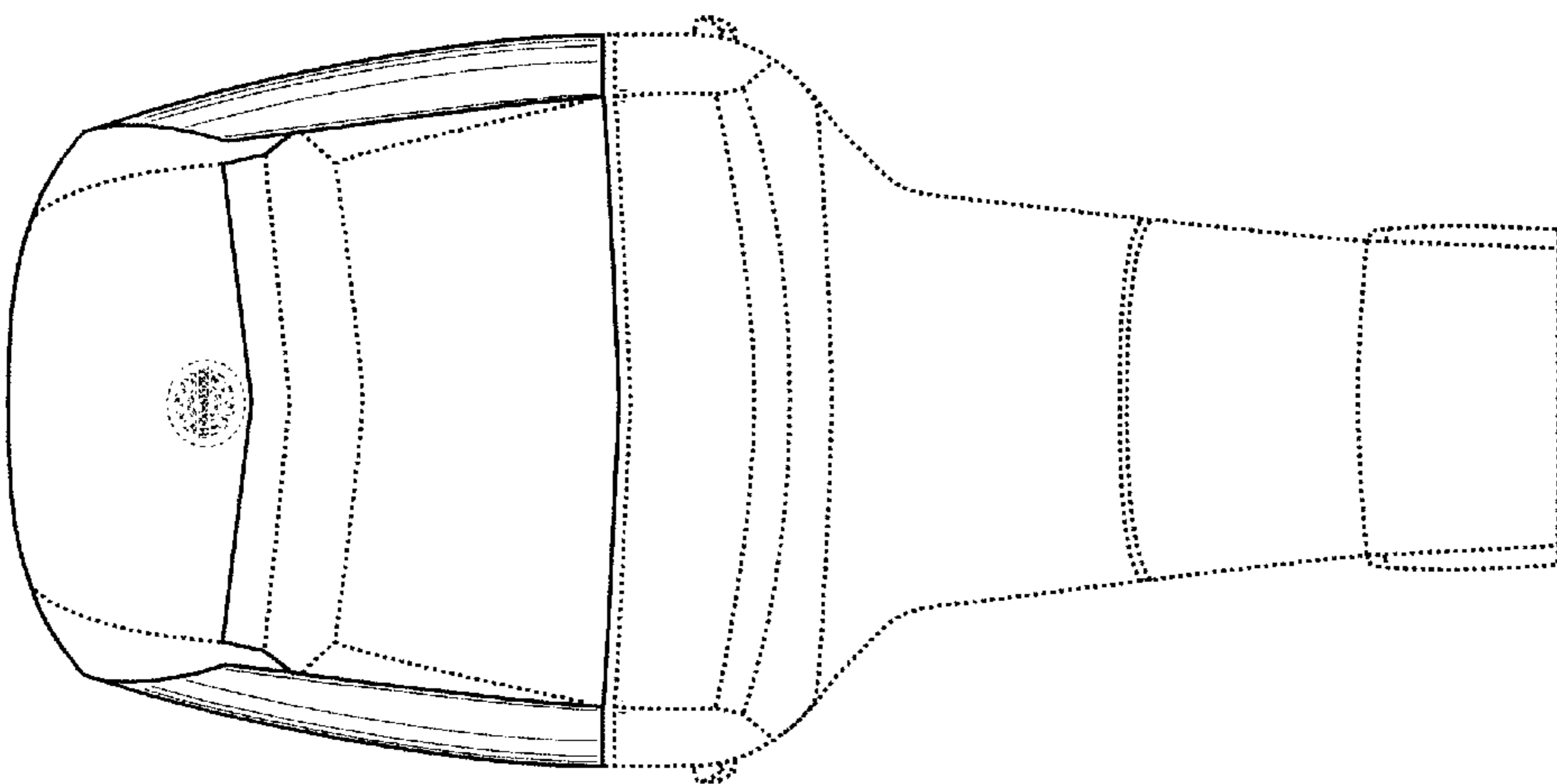

FIG. 10

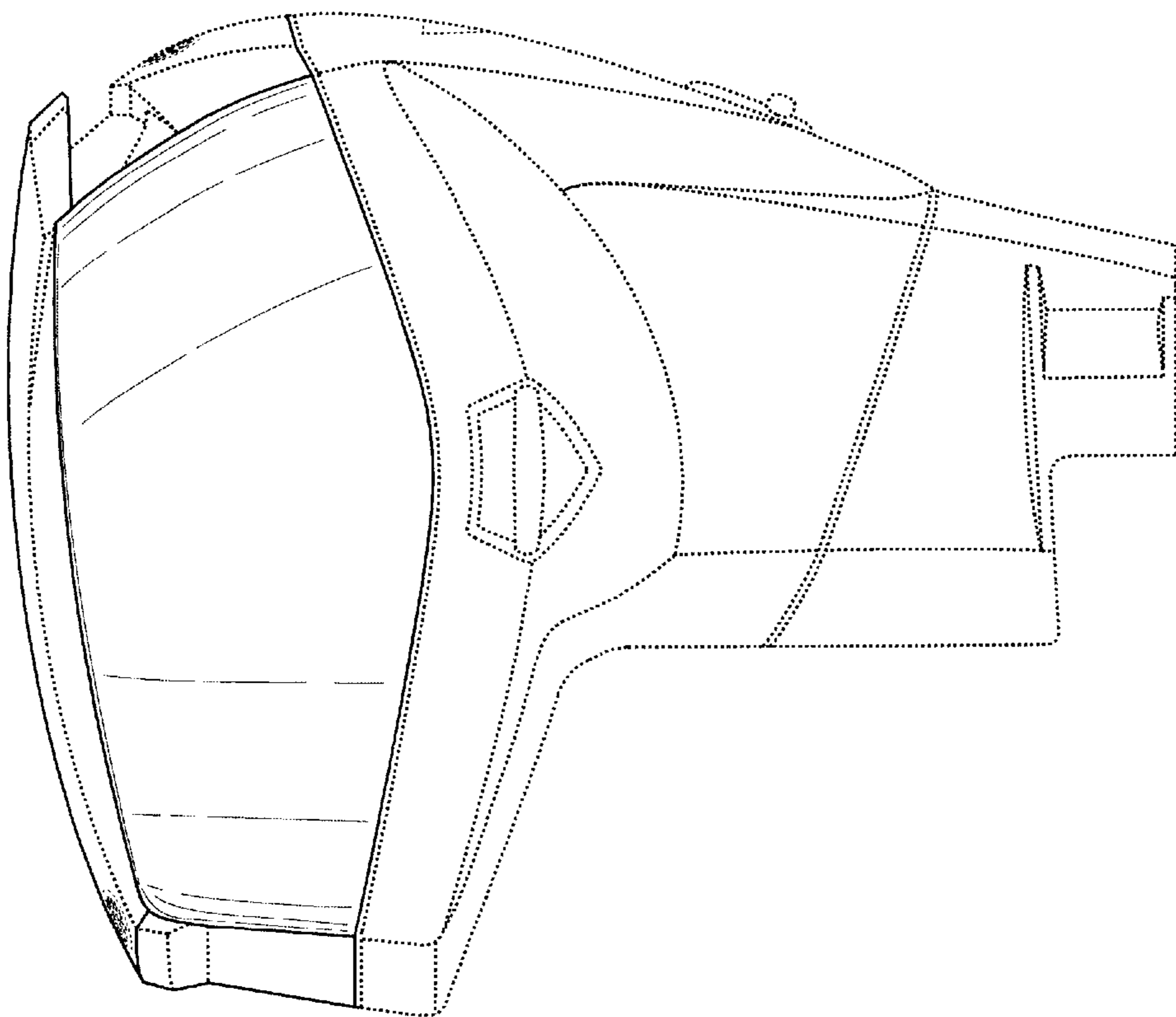

FIG. 11

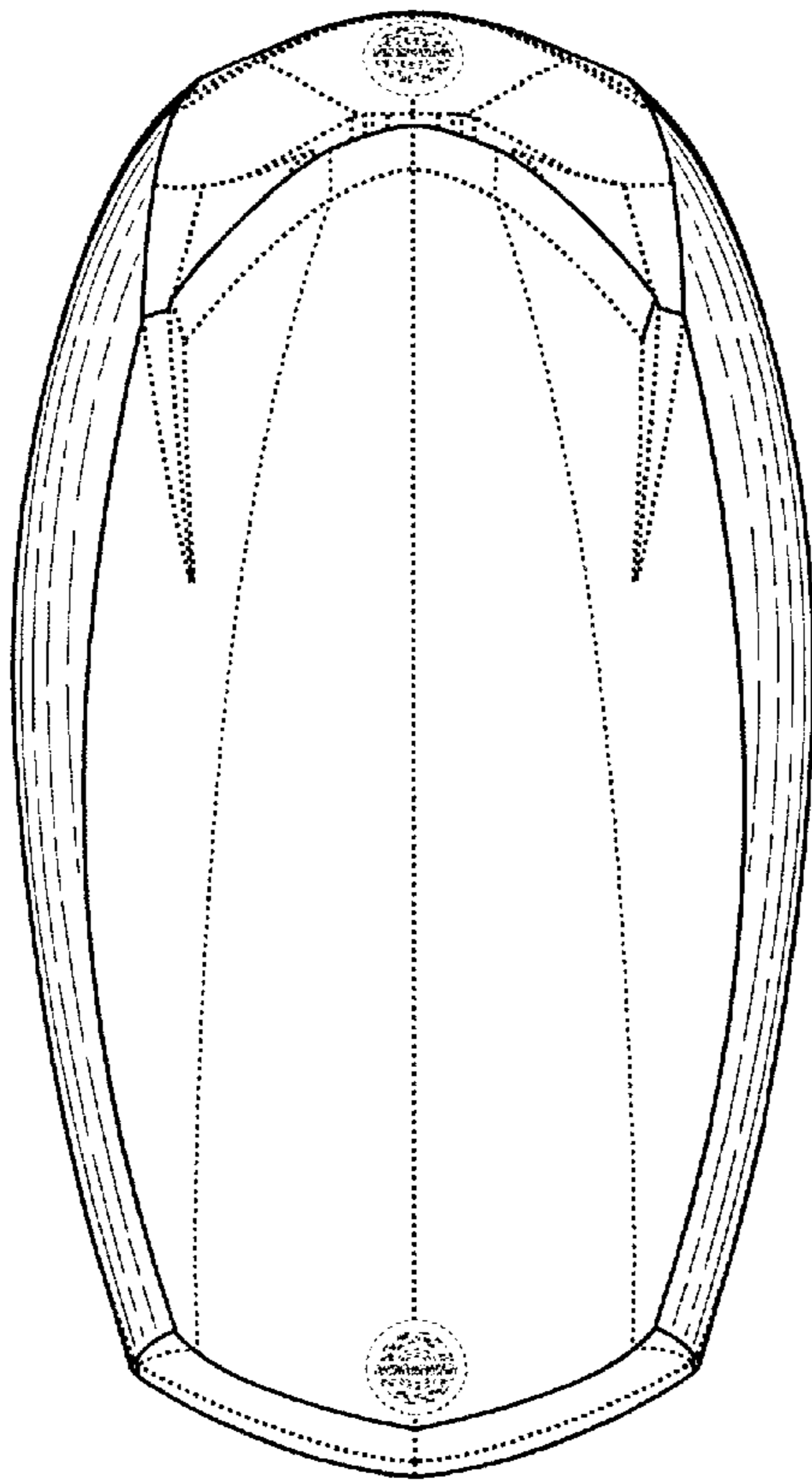

FIG. 12