



US00D485801S

(12) **United States Design Patent**  
**Smith**

(10) **Patent No.:** **US D485,801 S**  
(45) **Date of Patent:** **\*\* Jan. 27, 2004**

(54) **REMOVABLE DRAWER FOR AN  
AUTOMOBILE GLOVE COMPARTMENT**

(76) Inventor: **Glen R. Smith**, 2440 Alki Ave.  
Southwest, #102, Seattle, WA (US)  
98116

(\*\*) Term: **14 Years**

(21) Appl. No.: **29/152,987**

(22) Filed: **Dec. 31, 2001**

(51) **LOC (7) Cl.** ..... **12-16**

(52) **U.S. Cl.** ..... **D12/415**

(58) **Field of Search** ..... D12/414, 415,  
D12/423-426, 426.1; 296/37.12, 37.8, 37.1,  
37.9, 97.5, 97.8; 312/351, 194-195, 245,  
328, 319.1, 334.8; 108/25, 60-61, 91-92,  
102, 143; 16/82, 85; 220/528; 224/539-541,  
281, 551

D233,428 S	10/1974	Hestand
4,099,814 A	7/1978	Hasselberger
D264,894 S	6/1982	Halder
4,355,837 A	10/1982	Shimizu et al.
4,445,720 A	5/1984	Leaf et al.
4,552,399 A	11/1985	Atarashi
4,596,416 A	6/1986	Müller
4,630,857 A	12/1986	Zweiniger et al.
4,811,981 A	3/1989	Benson
4,854,632 A	8/1989	Kreuze et al.
4,886,311 A	12/1989	Trube et al.
4,902,061 A	2/1990	Plavetich et al.
4,930,737 A	6/1990	McNeill
5,052,762 A	10/1991	Nguyen et al.
5,065,920 A	11/1991	Amner
5,094,375 A	3/1992	Wright
D331,213 S	11/1992	Weinstock
5,190,314 A	3/1993	Takasugi
5,197,775 A	3/1993	Reeber
5,282,556 A	2/1994	Bossert
D348,867 S	7/1994	Snyder
5,385,378 A	1/1995	Hakamada et al.

(List continued on next page.)

(56) **References Cited**

**U.S. PATENT DOCUMENTS**

2,177,575 A	10/1939	Maxwell et al.
2,215,208 A	9/1940	Burkhart
2,226,434 A	12/1940	Hirsch
2,275,060 A	3/1942	Griffin
2,301,730 A	11/1942	Mann
2,382,011 A	8/1945	Howard
2,443,381 A	6/1948	Farrar, Jr.
2,554,685 A	5/1951	St. Denis
D163,954 S	7/1951	Kulwin
2,592,032 A	4/1952	Henderson
D166,957 S	6/1952	Ershler
2,657,967 A	11/1953	Gilchrist
2,736,428 A	2/1956	Wenger
2,789,861 A	4/1957	Hudson
2,796,310 A	6/1957	Anderson
2,820,687 A	1/1958	Waring
2,883,234 A	4/1959	Biondo
3,039,642 A	6/1962	Perkins
3,132,892 A	5/1964	Stevens
D199,462 S	10/1964	Zack et al.
3,503,648 A	3/1970	James

*Primary Examiner*—Stacia Cadmus

(74) *Attorney, Agent, or Firm*—Black Lowe & Graham  
PLLC

(57) **CLAIM**

The ornamental design for a removable drawer for an automobile glove compartment, as shown and described.

**DESCRIPTION**

FIG. 1 is a front, top, right side isometric view of a removable drawer for an automobile glove compartment showing my new design;  
FIG. 2 is a front view thereof;  
FIG. 3 is a rear view thereof;  
FIG. 4 is a left side view thereof;  
FIG. 5 is a right side view thereof;  
FIG. 6 is a top view thereof; and,  
FIG. 7 is a bottom view thereof.

**1 Claim, 3 Drawing Sheets**

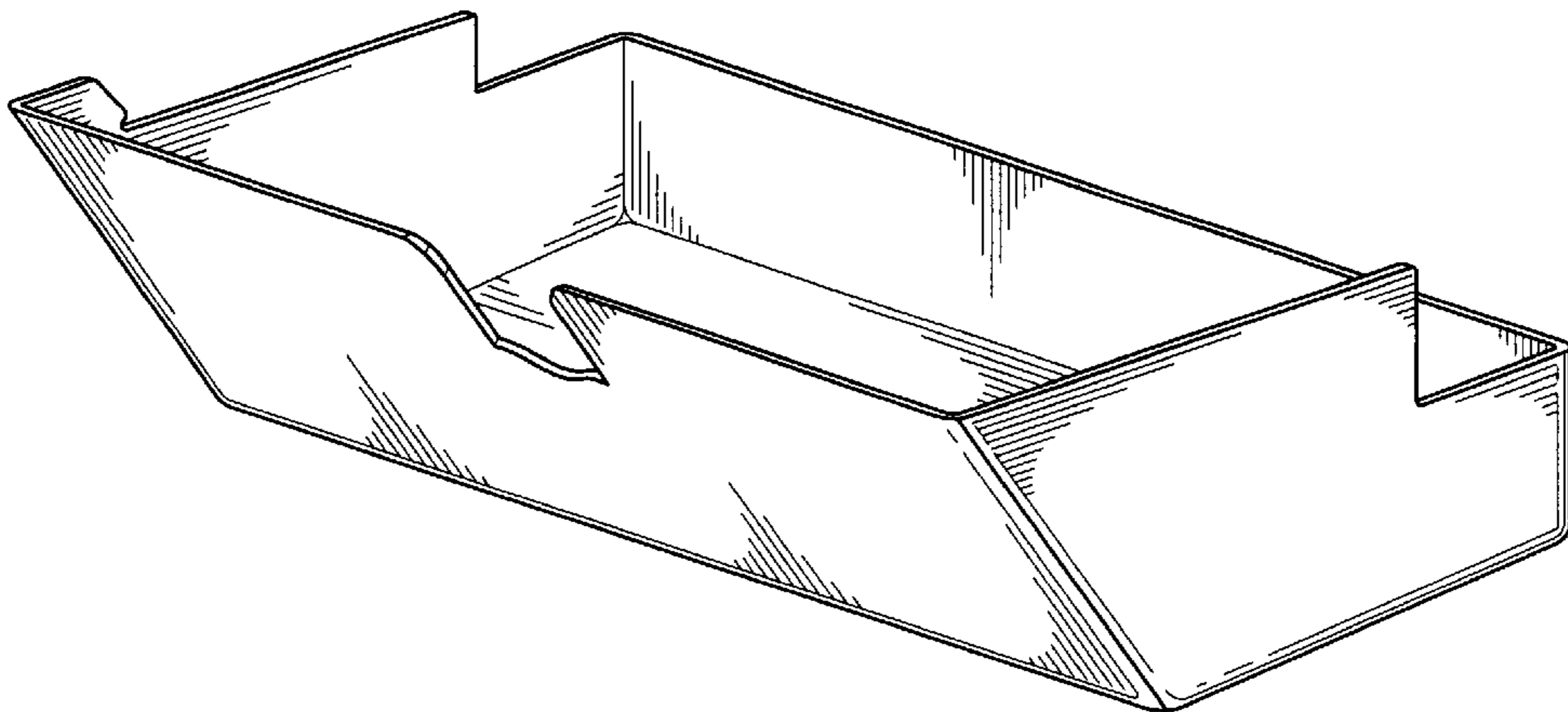

# US D485,801 S

Page 2

---

## U.S. PATENT DOCUMENTS

5,460,309 A	10/1995	Nehl et al.	5,810,414 A	9/1998	Choquet
5,489,054 A	2/1996	Schiff	5,823,612 A	10/1998	Angelo
5,516,177 A	5/1996	Lively	5,845,954 A	12/1998	DePue
5,551,616 A	9/1996	Stitt et al.	5,868,448 A	2/1999	Izumo
5,558,385 A	9/1996	Gross et al.	5,904,389 A	5/1999	Vaishnav et al.
5,630,630 A	5/1997	Price et al.	D410,620 S	6/1999	Sacco et al.
5,636,890 A	6/1997	Cooper	5,971,463 A	10/1999	Nowak et al.
5,660,311 A	8/1997	Soltau	6,050,628 A	4/2000	Allison et al.
5,785,222 A	7/1998	Basso et al.	6,076,878 A	6/2000	Isano
			6,106,085 A	8/2000	Berrito et al.
			D433,663 S	11/2000	Bergh

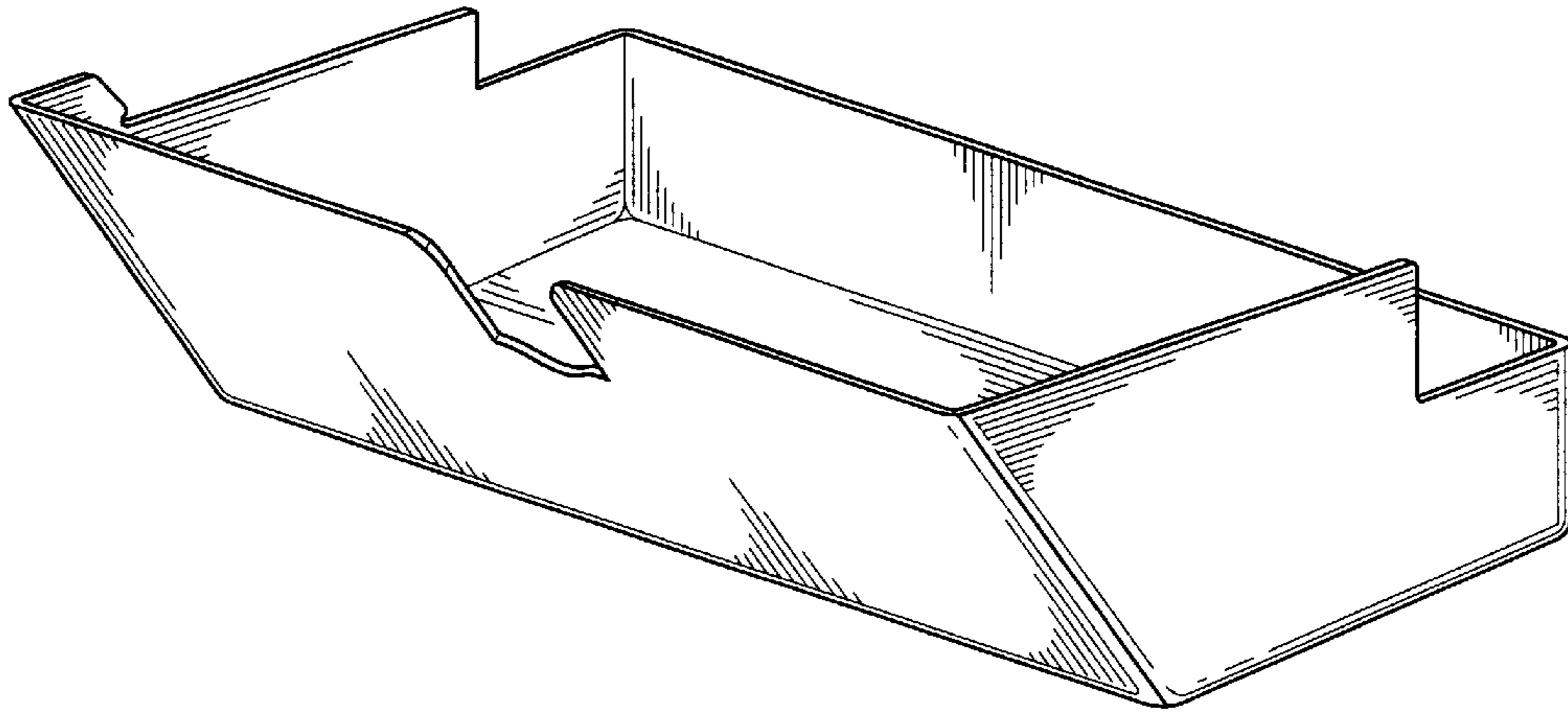

*Fig. 1.*

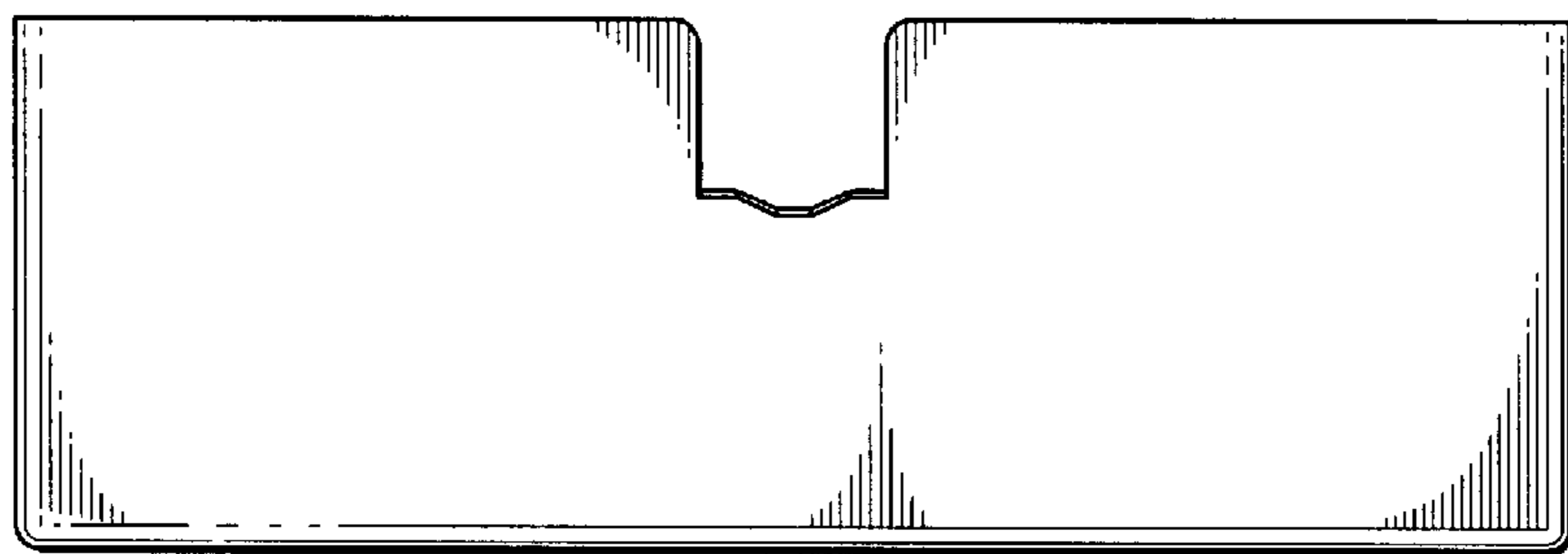

*Fig. 2.*

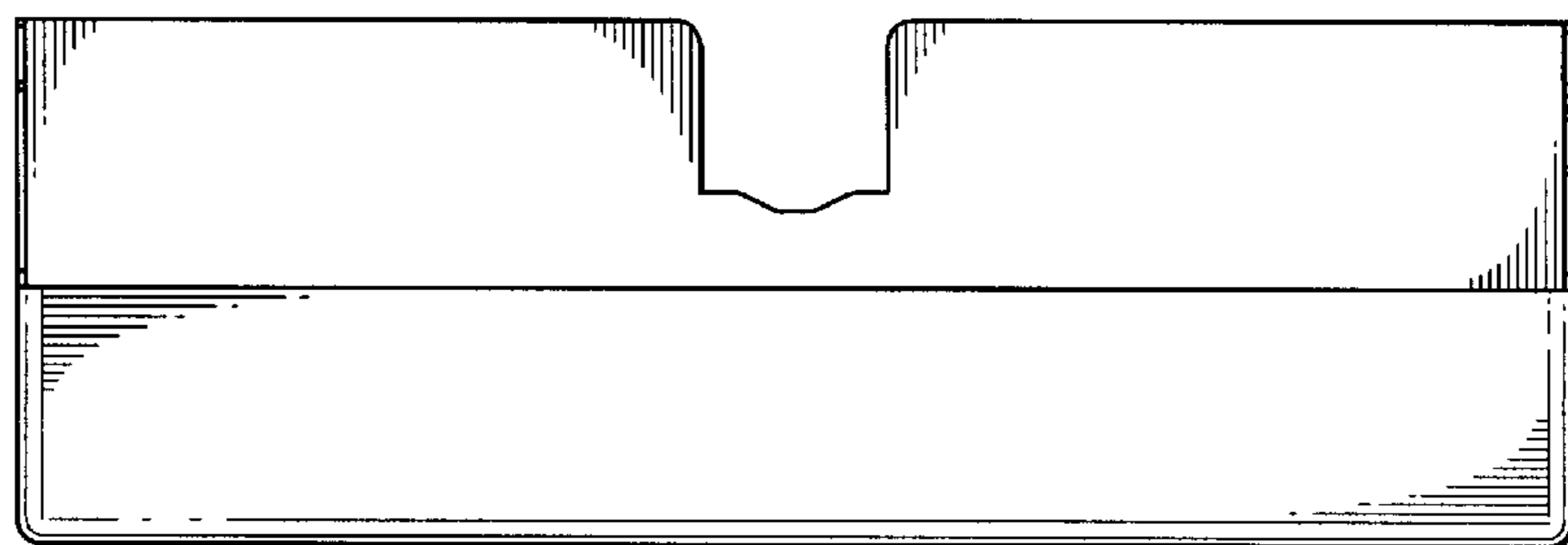

*Fig. 3.*

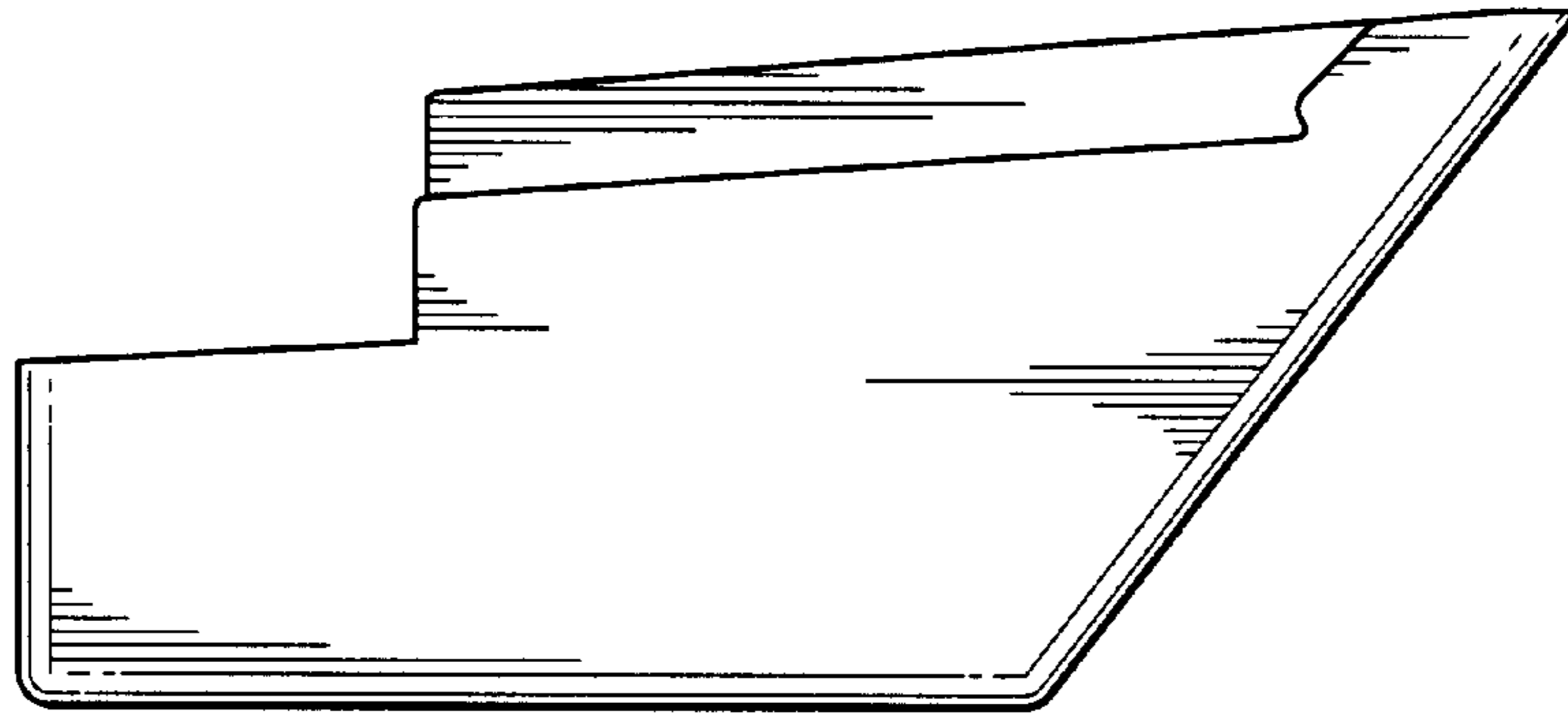

*Fig. 4.*

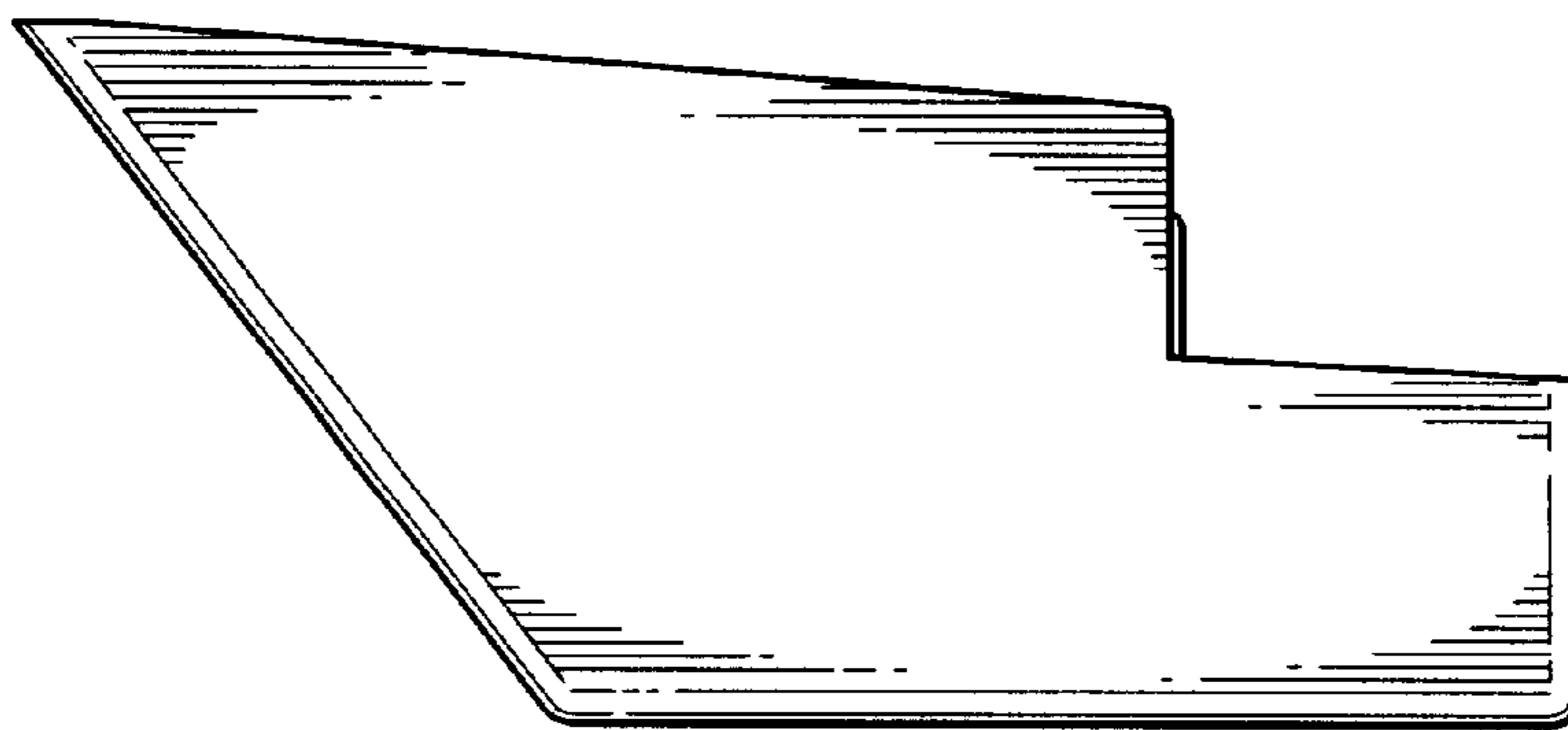

*Fig. 5.*

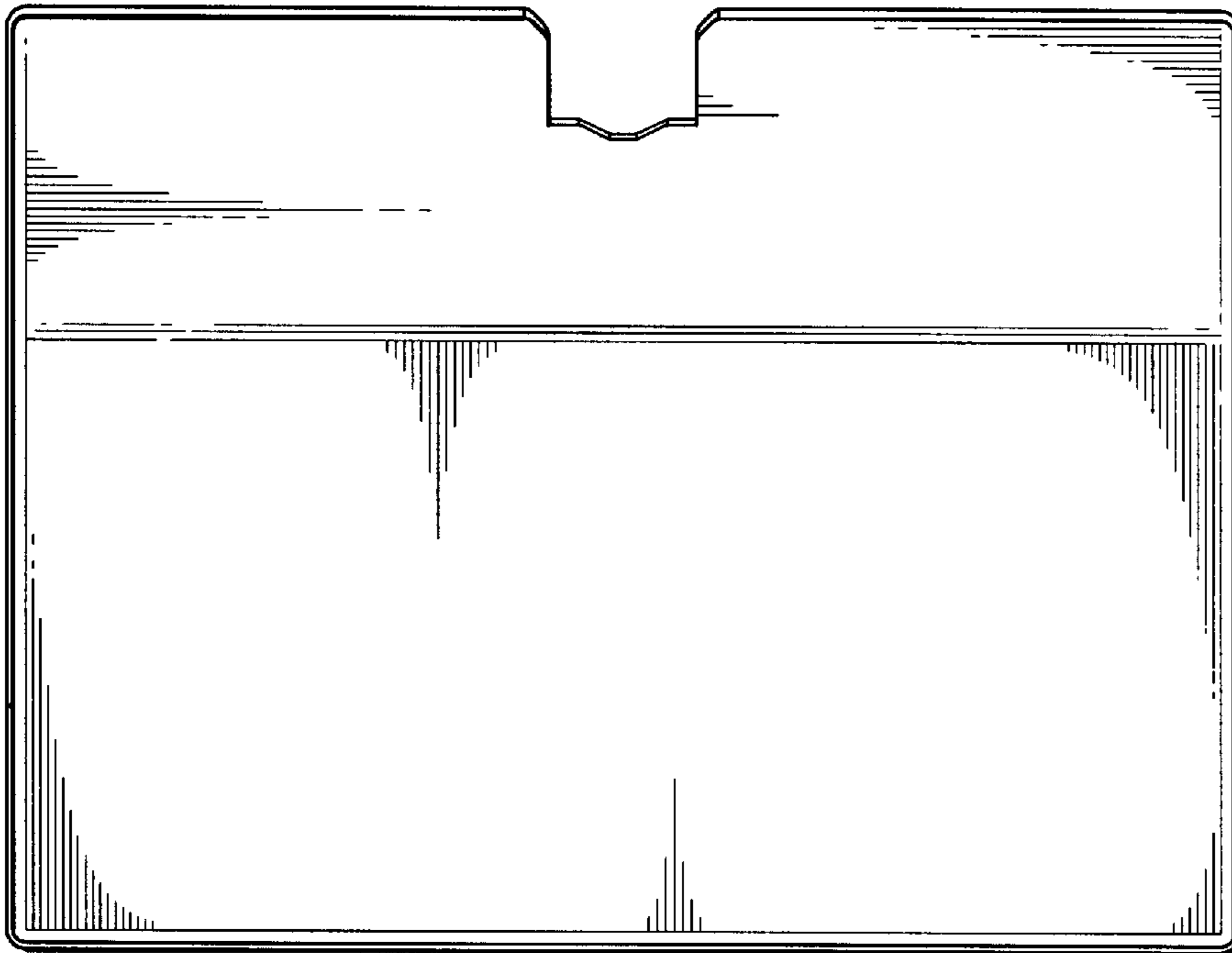

*Fig. 6.*

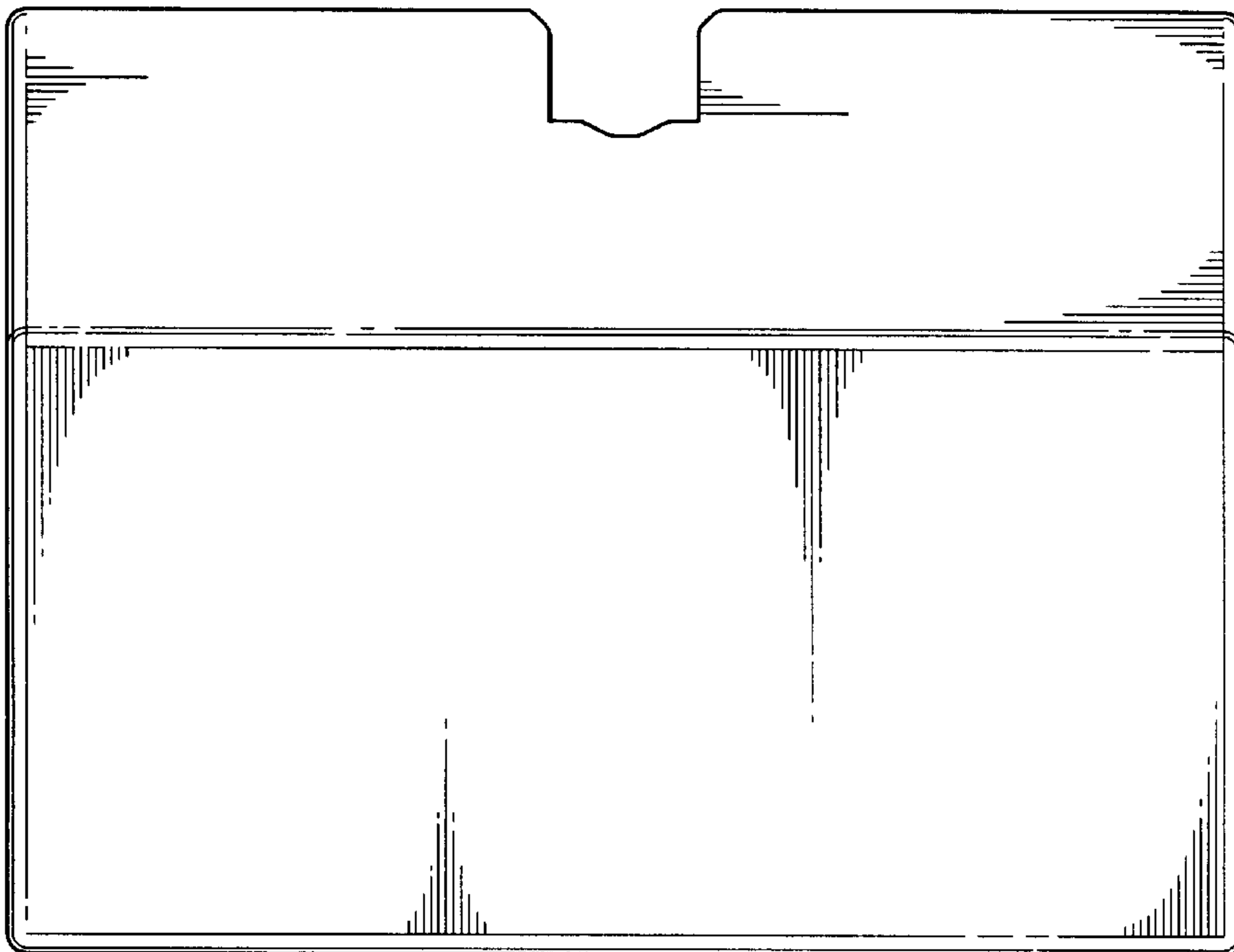

*Fig. 7.*