



US00D485800S

(12) **United States Design Patent**
Smith

(10) **Patent No.:** **US D485,800 S**

(45) **Date of Patent:** **** Jan. 27, 2004**

(54) **CARGO BAY EXTENDER FOR A PICKUP TRUCK**

(76) Inventor: **Dean P. Smith**, 4111 243rd St., Ct. E.,
Spanaway, WA (US) 98387-7069

(**) Term: **14 Years**

(21) Appl. No.: **29/156,597**

(22) Filed: **Mar. 5, 2002**

(51) **LOC (7) Cl.** **12-16**

(52) **U.S. Cl.** **D12/414**

(58) **Field of Search** D12/414.1, 414,
D12/400; 296/26.08, 26.11, 37.1, 37.6,
50, 57.1, 60-61, 39.1-39.2, 26.09; 224/402-404,
495-496, 498, 502, 328; 280/163, 166

(56) **References Cited**

U.S. PATENT DOCUMENTS

4,472,639	A	*	9/1984	Bianchi	296/57.1
D291,789	S	*	9/1987	Noga	D12/414
4,909,558	A		3/1990	Roshinsky		
5,456,511	A		10/1995	Webber		
5,468,038	A		11/1995	Sauri		
5,501,500	A		3/1996	Cannon		
5,752,636	A		5/1998	Manley		
5,752,800	A		5/1998	Brincks et al.		
5,775,759	A	*	7/1998	Cummins	296/26
5,816,637	A	*	10/1998	Adams et al.	296/26.09
5,820,188	A	*	10/1998	Nash	296/26
5,823,596	A	*	10/1998	Kulesza	296/26.08
5,902,000	A	*	5/1999	Wold	296/26
D417,859	S	*	12/1999	Leitner et al.	D12/414

D418,106	S	*	12/1999	Leitner et al.	D12/414
5,997,066	A	*	12/1999	Scott	296/26.08
6,007,127	A	*	12/1999	Garofalo	296/26.11
6,322,125	B2	*	11/2001	Bauer	296/57.1
6,340,190	B1	*	1/2002	Rosebrugh et al.	296/26.11
6,422,627	B1	*	7/2002	Kuhn et al.	296/26.1
6,422,630	B1	*	7/2002	Heaviside	296/57.1
6,550,836	B2	*	4/2003	Rigau	296/37.6
6,550,841	B1	*	4/2003	Burdon et al.	296/57.1

* cited by examiner

Primary Examiner—Stacia Cadmus

(74) *Attorney, Agent, or Firm*—Donald R. Schoonover

(57) **CLAIM**

I claim the ornamental design for a cargo bay extender for a pickup truck, as shown and described.

DESCRIPTION

FIG. 1 is a perspective view of a cargo bay extender for a pickup truck embodying the design of the present invention. FIG. 2 is a rear elevational view thereof; FIG. 3 is a front elevational view thereof; FIG. 4 is a right side elevational view thereof, the left side being identical but a mirror image thereof; FIG. 5 is a top plan view thereof; FIG. 6 is a bottom plan view; and, FIG. 7 is a perspective view showing the cargo bay extender for a pickup truck in a storage configuration. The broken line showing of environmental structure is for illustrative purposes only and forms no part of the claimed design.

1 Claim, 4 Drawing Sheets

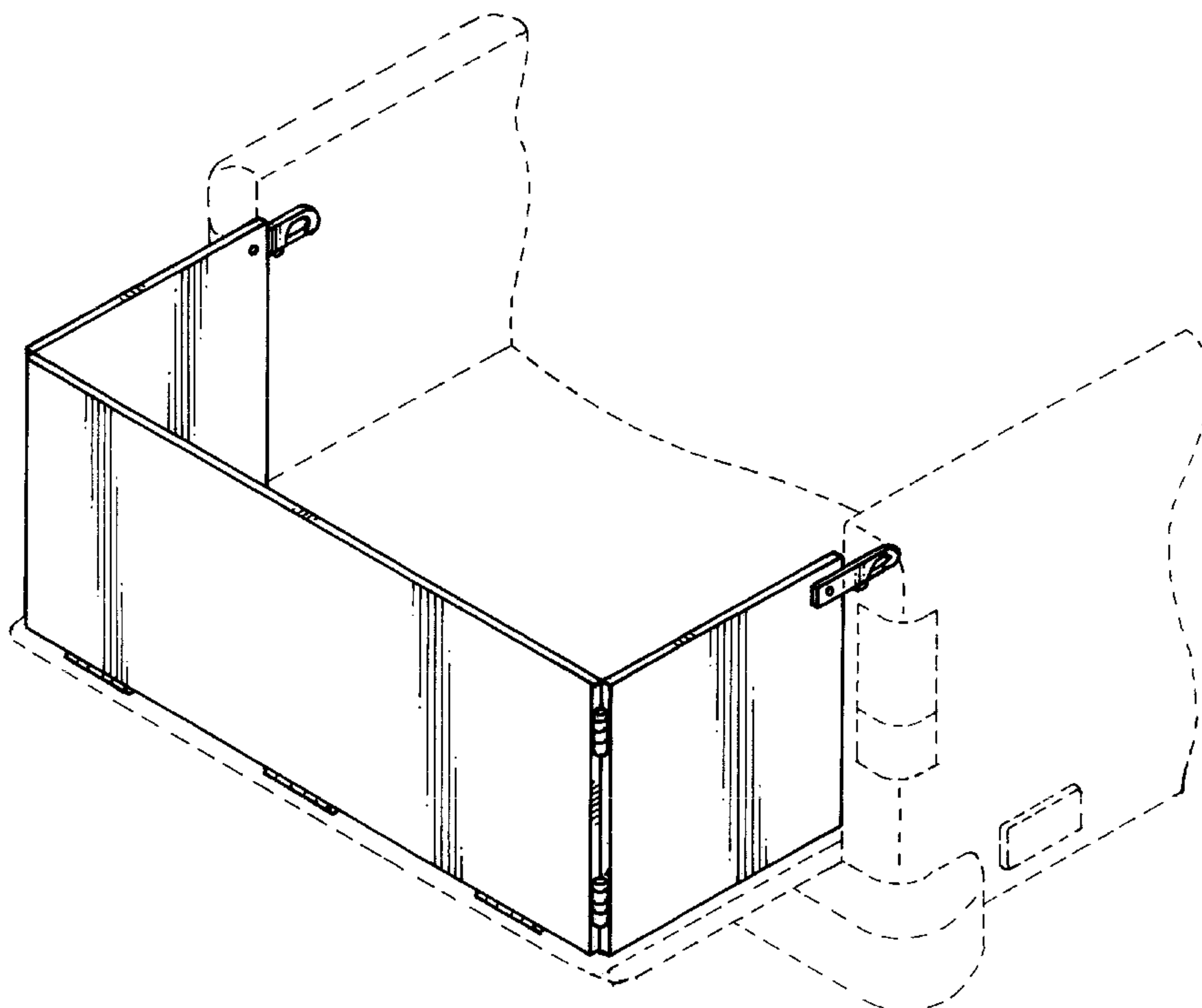

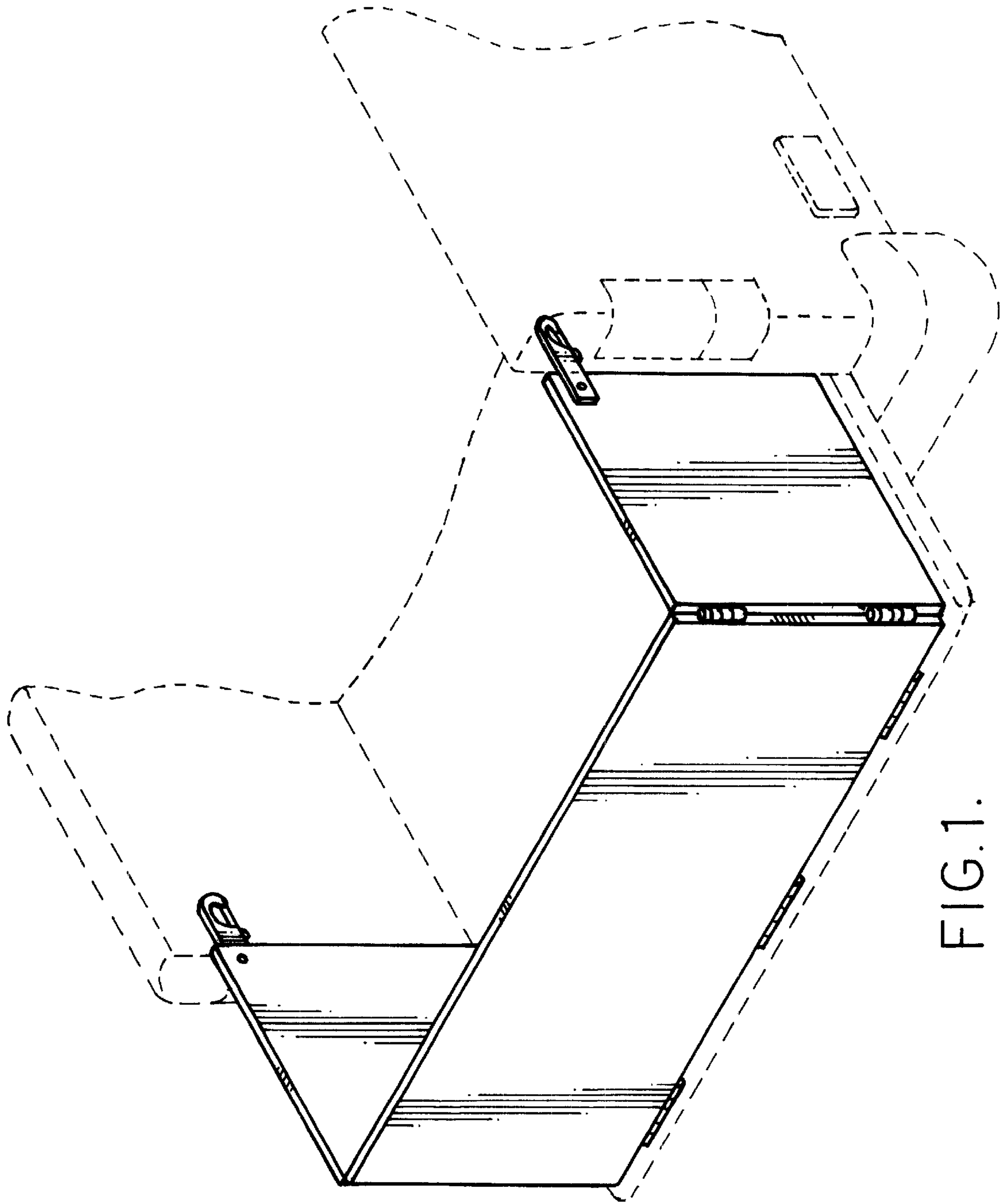

FIG.1.

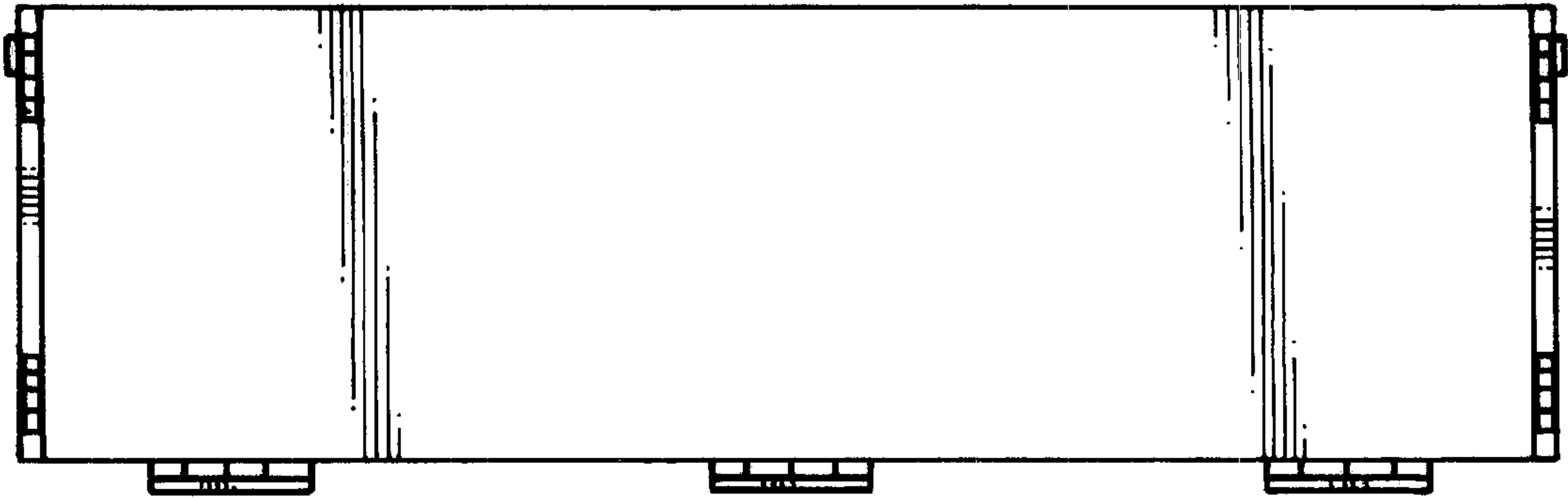

FIG. 2.

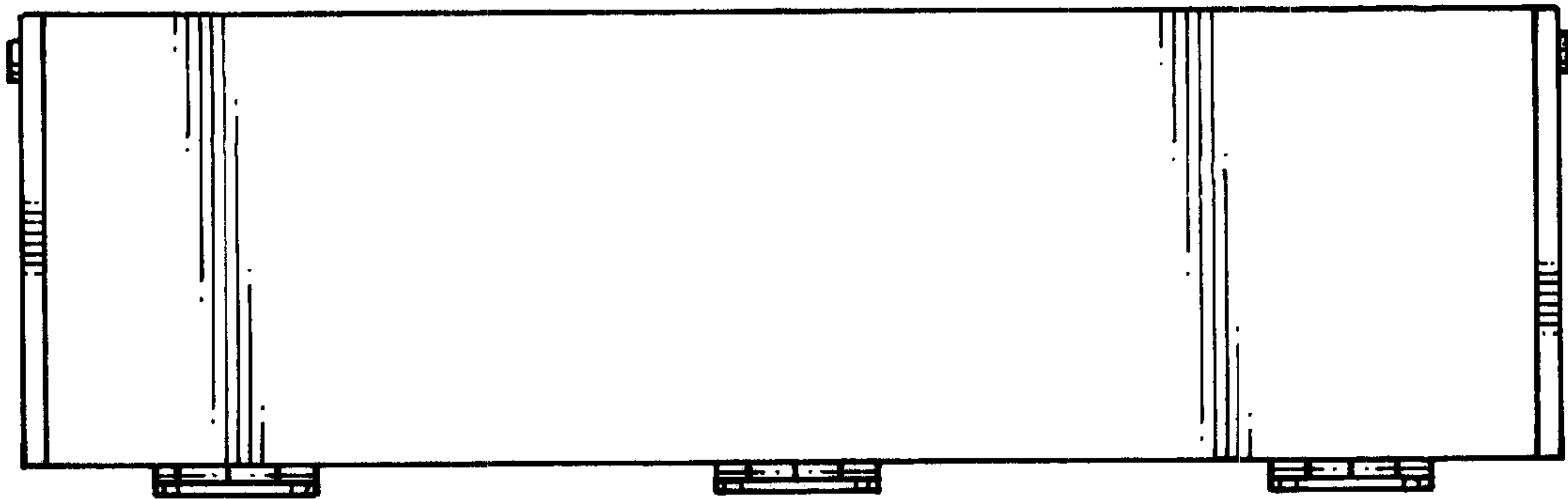

FIG. 3.

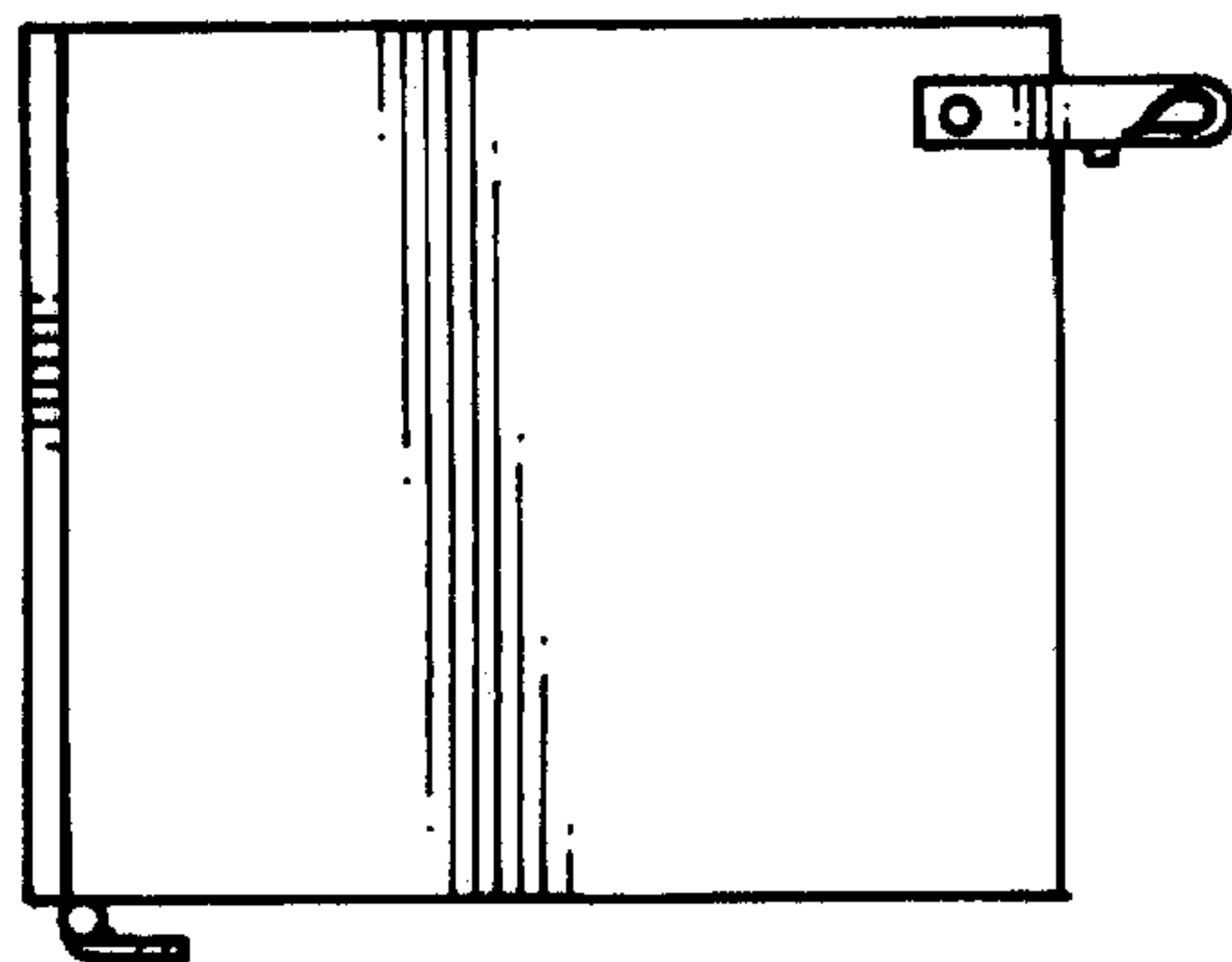

FIG. 4.

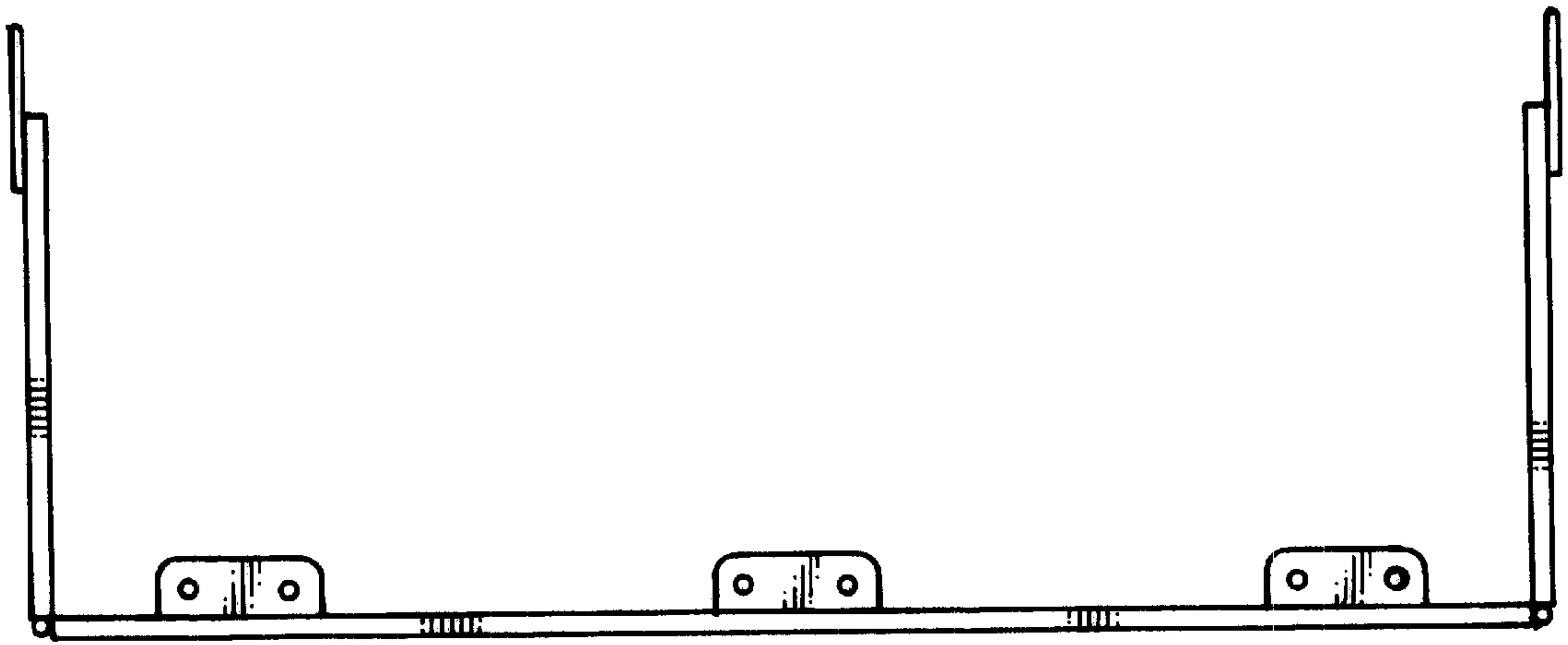

FIG. 5

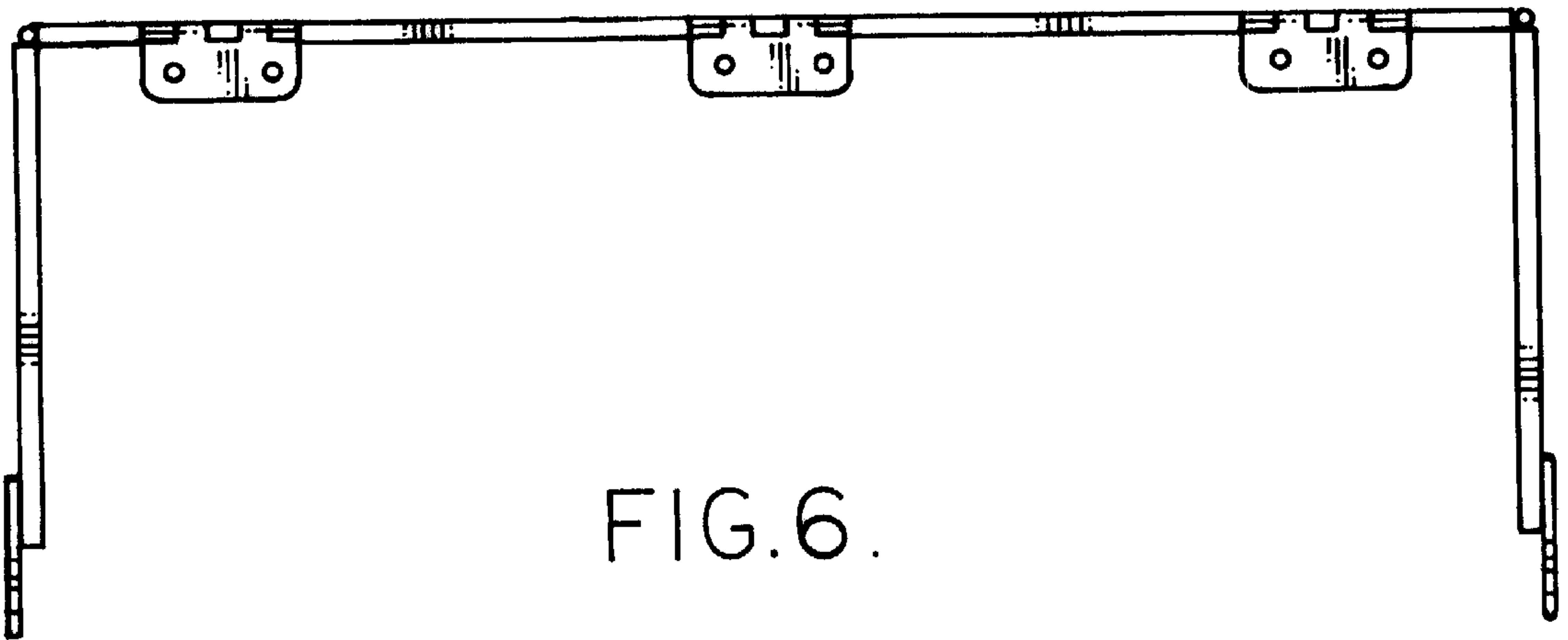

FIG. 6.

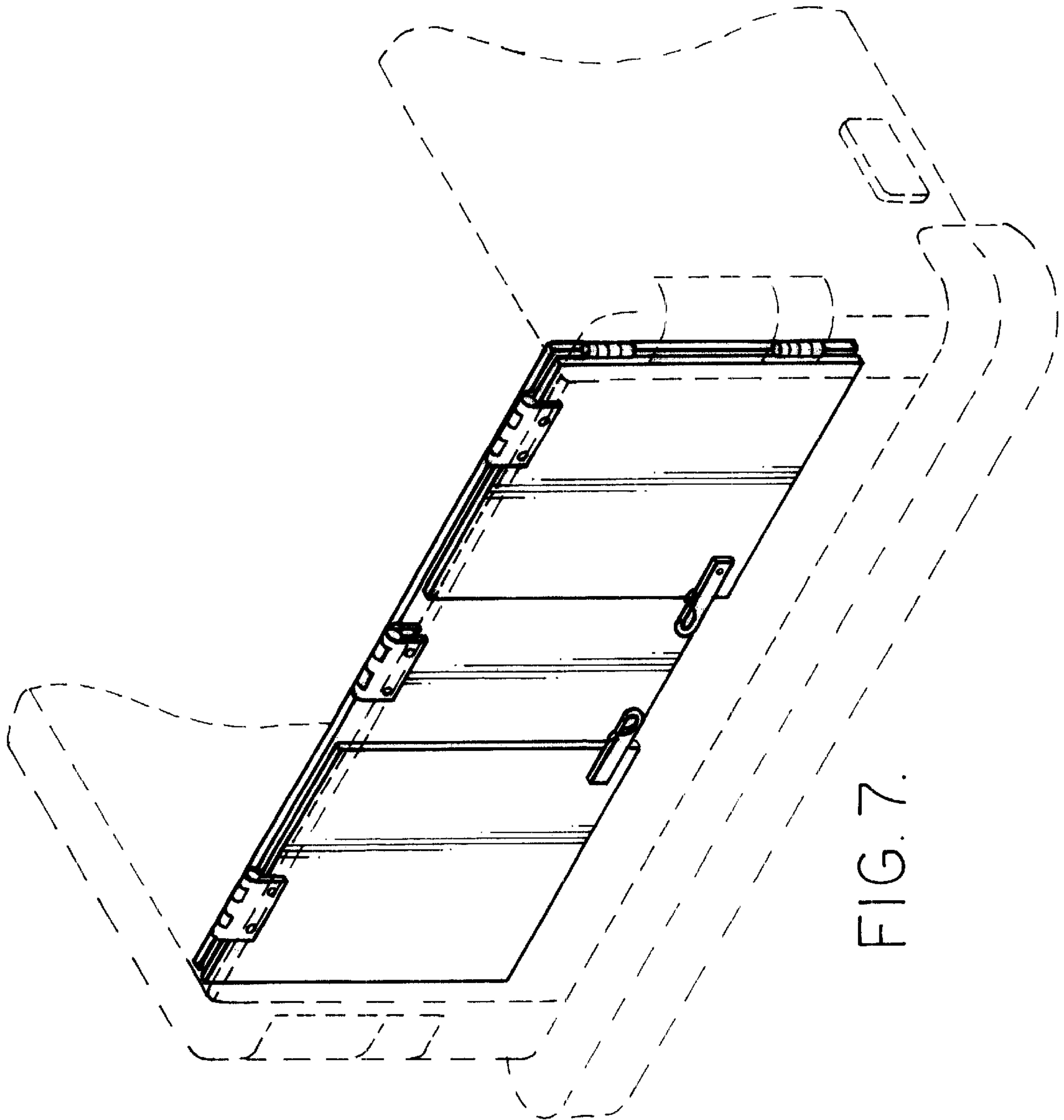

FIG. 7.