



US00D485790S

(12) **United States Design Patent**
Sprague

(10) **Patent No.:** **US D485,790 S**

(45) **Date of Patent:** **** Jan. 27, 2004**

(54) **MOTORCYCLE FOOT REST**

(76) Inventor: **Bert Sprague**, P.O. Box 155, Payson,
AZ (US) 85547

(**) Term: **14 Years**

(21) Appl. No.: **29/174,079**

(22) Filed: **Jan. 9, 2003**

(51) **LOC (7) Cl.** **12-11**

(52) **U.S. Cl.** **D12/114**

(58) **Field of Search** D12/110, 114,
D12/122; 180/219; 280/288.4, 291; 296/75;
74/564; D30/157; 54/83.1, 83.2

(56) **References Cited**

U.S. PATENT DOCUMENTS

877,886 A * 1/1908 Crowder 54/83.2
D209,214 S * 11/1967 Markim D30/157

* cited by examiner

Primary Examiner—Alan P. Douglas

Assistant Examiner—Linda Brooks

(74) *Attorney, Agent, or Firm*—Schmeiser, Olsen & Watts
LLP

(57) **CLAIM**

The ornamental design for a motorcycle foot rest, as shown
and described.

DESCRIPTION

FIG. 1 is a right rear perspective view of the motorcycle foot
rest;

FIG. 2 is a top plan view of the motorcycle foot rest;

FIG. 3 is a rear elevational view of the motorcycle foot rest;

FIG. 4 is a side elevational view of the right side of the
motorcycle foot rest; a left side view would be a mirror
image of FIG. 4;

FIG. 5 is a bottom plan view of the motorcycle foot rest; and,

FIG. 6 is a front elevational view of the motorcycle foot rest.

The broken lines shown are for illustrative purposes only
and form no part the claimed design.

1 Claim, 5 Drawing Sheets

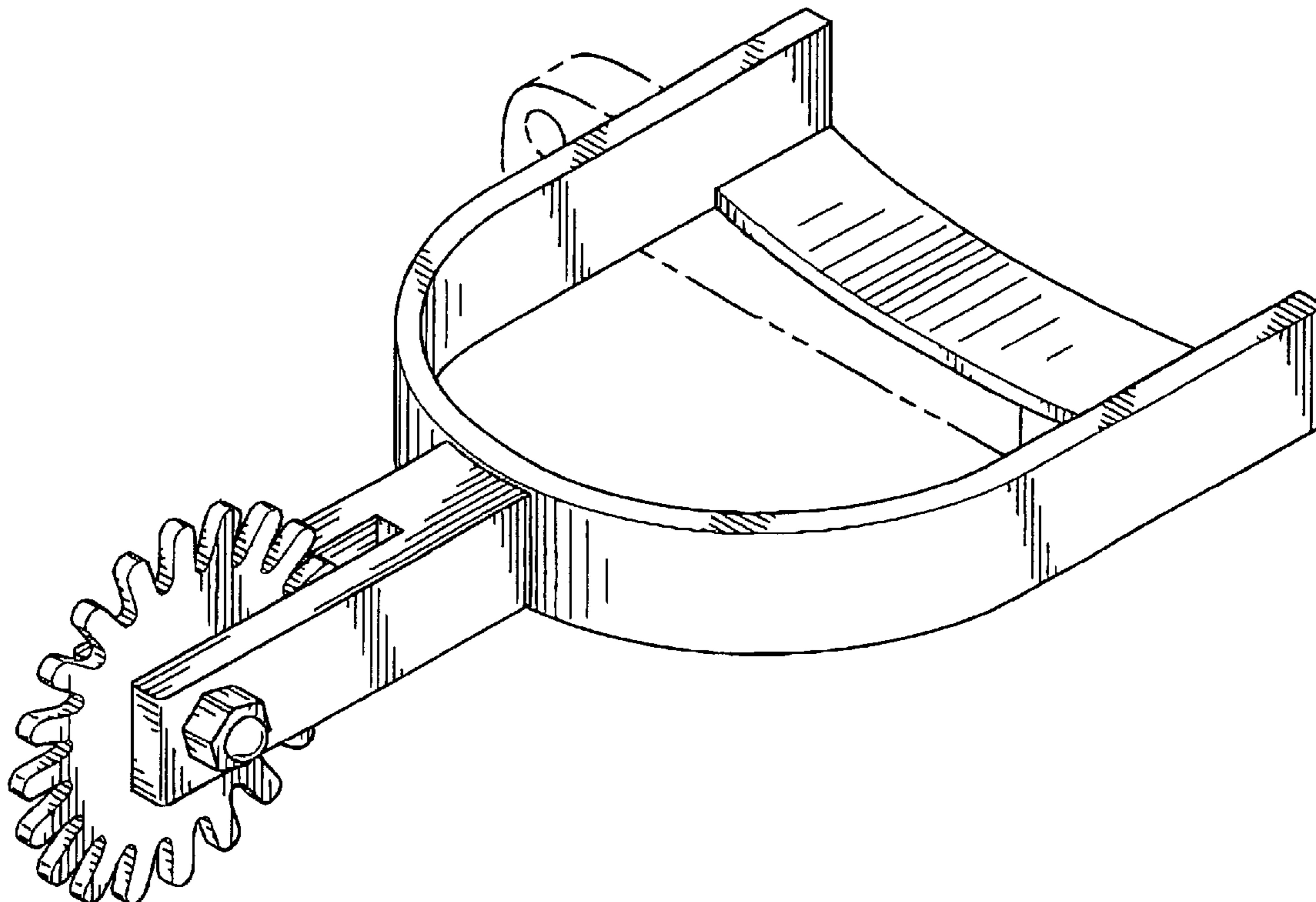

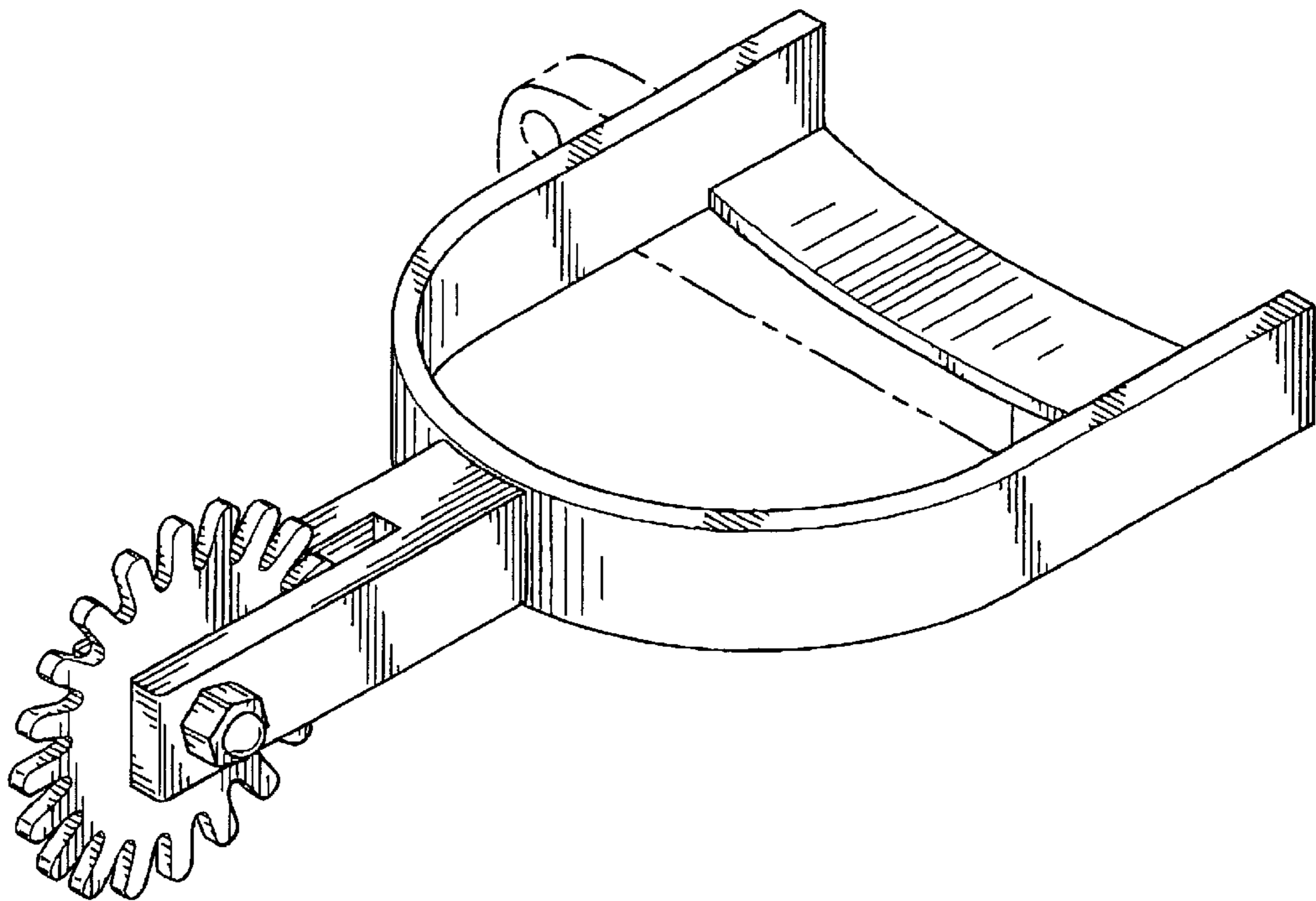

FIG. 1

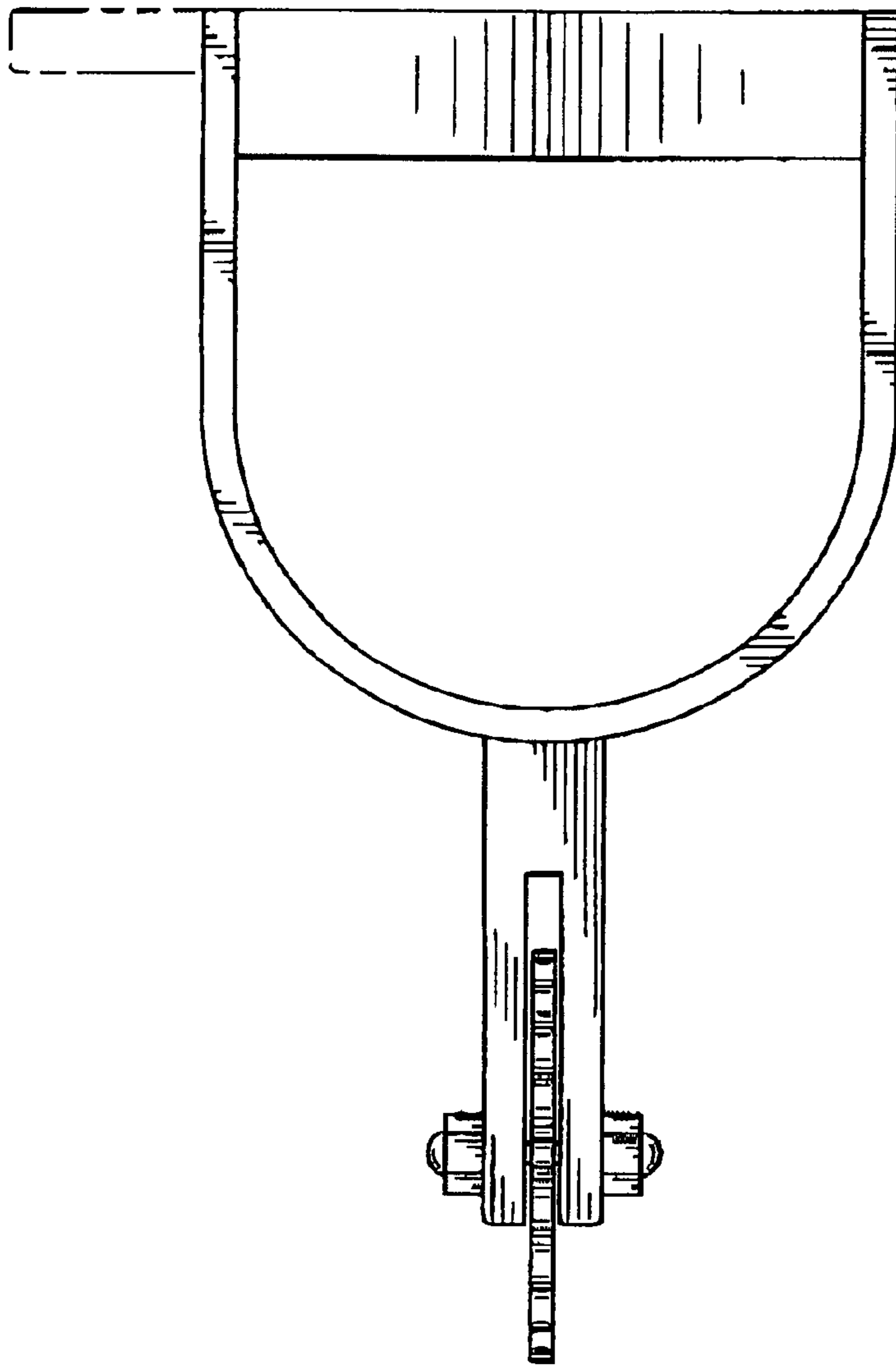

FIG. 2

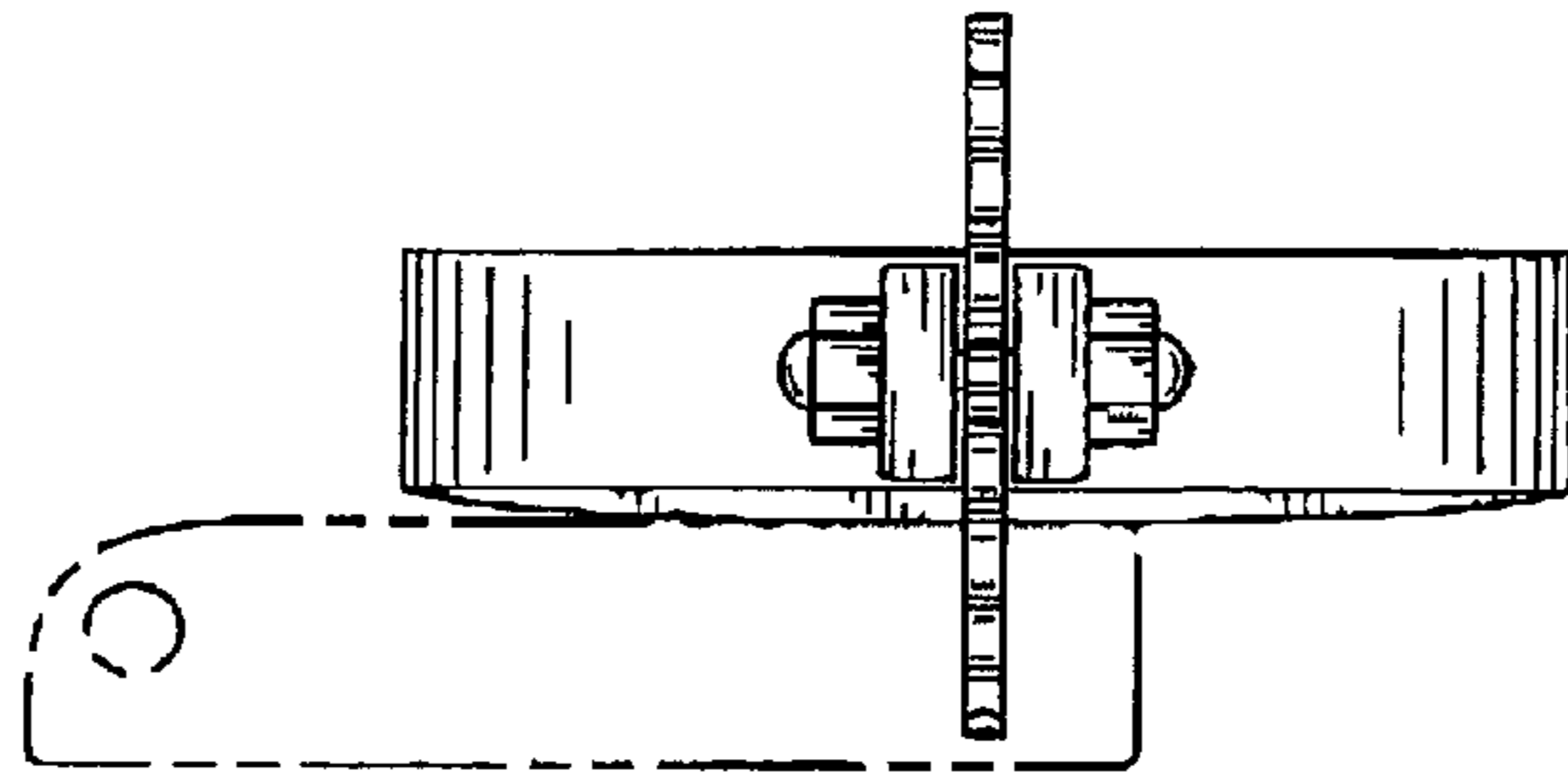

FIG. 3

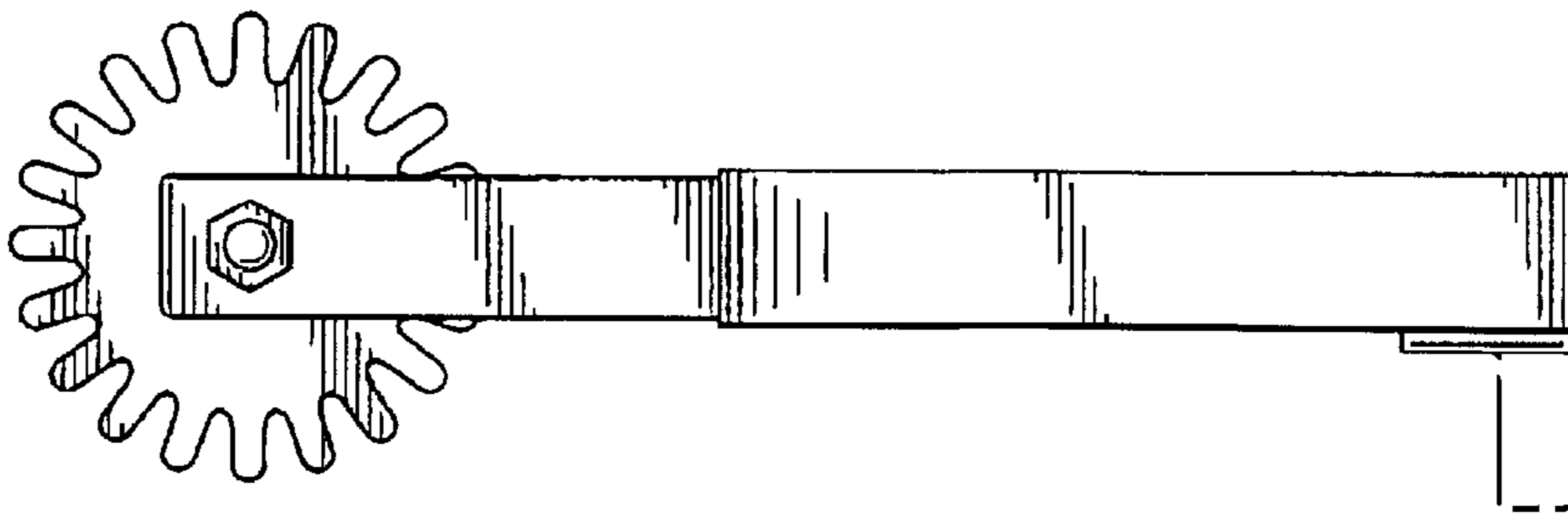

FIG. 4

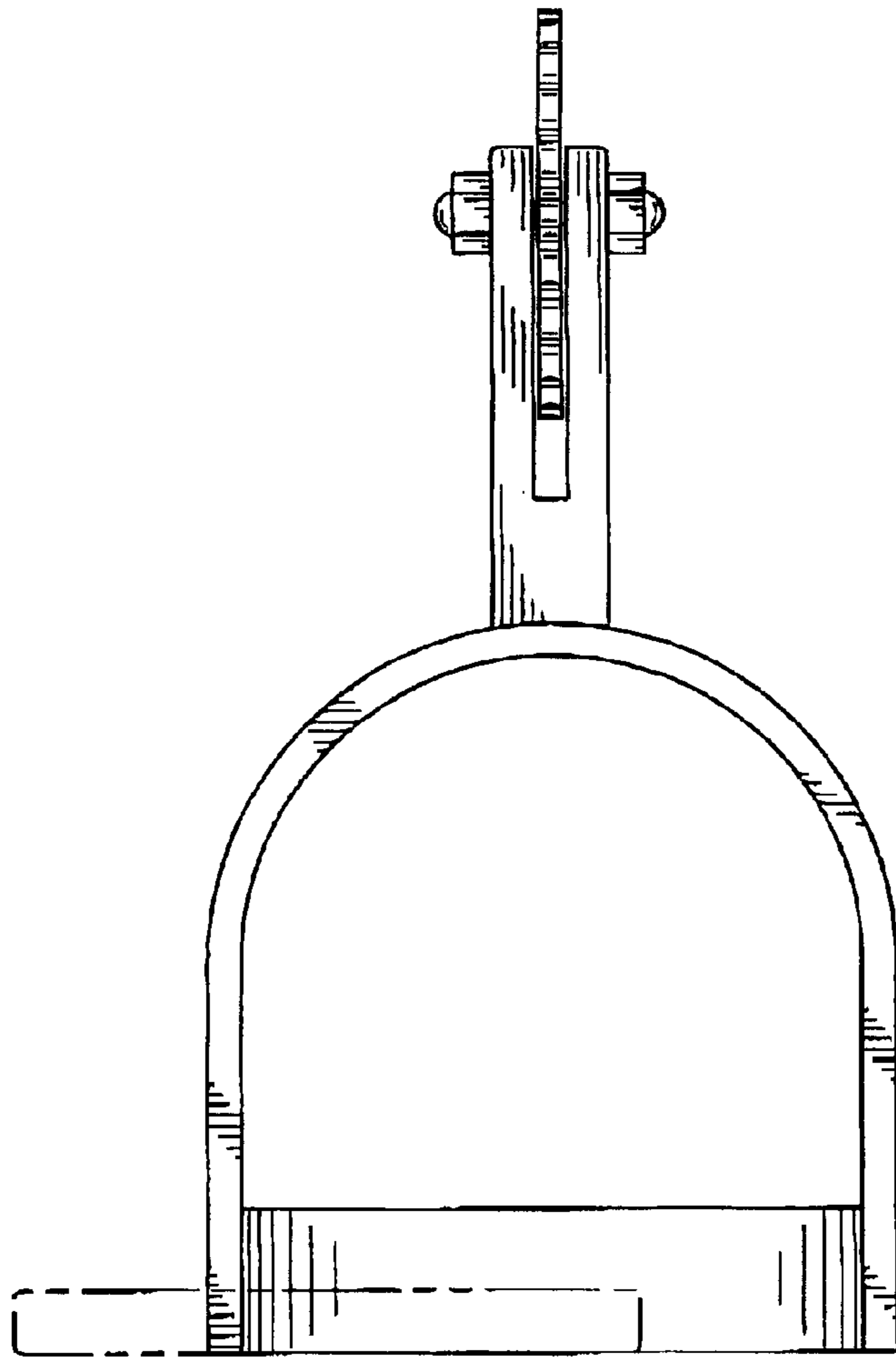

FIG. 5

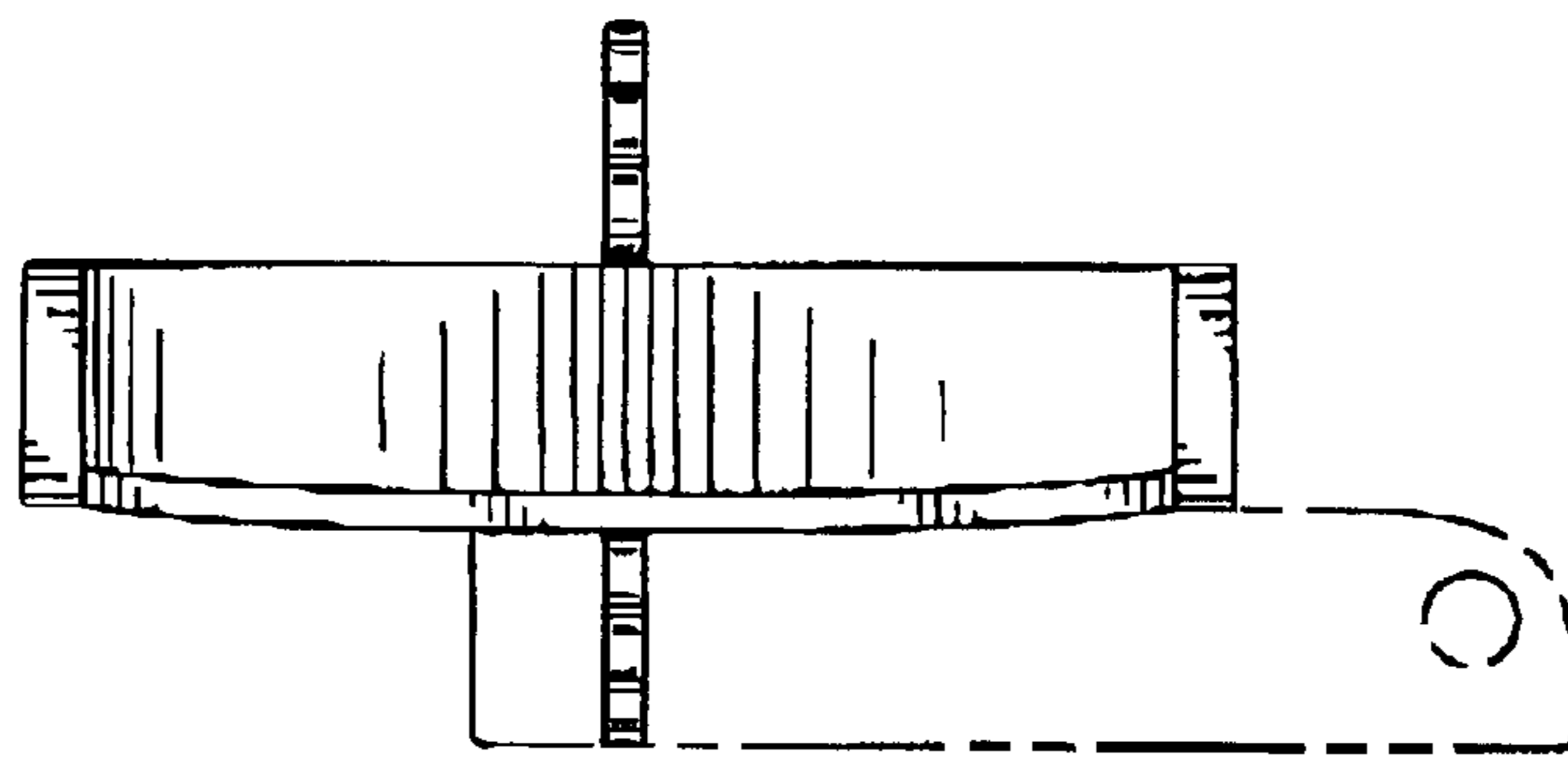

FIG. 6