



US00D485543S

(12) **United States Design Patent**  
**Allen**

(10) **Patent No.:** **US D485,543 S**  
(45) **Date of Patent:** **\*\* Jan. 20, 2004**

(54) **LOUDSPEAKER**

(75) **Inventor:** **Graham David Allen**, Alderley Edge (GB)

(73) **Assignee:** **KH Technology Corporation**, Grand Cayman (KY)

(\*\*) **Term:** **14 Years**

(21) **Appl. No.:** **29/175,689**

(22) **Filed:** **Feb. 6, 2003**

(30) **Foreign Application Priority Data**

Aug. 6, 2002 (GB) ..... 3006022

(51) **LOC (7) Cl.** ..... **14-01**

(52) **U.S. Cl.** ..... **D14/214; D14/215**

(58) **Field of Search** ..... D14/204, 207, D14/209-216, 356; 181/143-145, 147-148, 150, 153, 157, 198-199; 381/300-302, 306, 333, 345, 361-364, 386-388

(56) **References Cited**

**U.S. PATENT DOCUMENTS**

D277,752 S \* 2/1985 Nakamura ..... D14/214

D281,158 S \* 10/1985 Ishizaki ..... D14/214  
D369,356 S \* 4/1996 Olson ..... D14/214  
5,546,468 A \* 8/1996 Beard ..... 381/300  
D416,020 S \* 11/1999 Warren ..... D14/215

\* cited by examiner

*Primary Examiner*—Nanda Bondade

(74) *Attorney, Agent, or Firm*—Kenneth L. Sherman, Esq.; Myers Dawes Andras & Sherman, LLP

(57) **CLAIM**

The ornamental design for a loudspeaker, substantially as shown and described.

**DESCRIPTION**

FIG. 1 is a front view of the loudspeaker, shown with the front grille removed for clarity of illustration;  
FIG. 2 is a rear view thereof;  
FIG. 3 is a top view thereof;  
FIG. 4 is a left side view thereof;  
FIG. 5 is a top front perspective view thereof; and,  
FIG. 6 is a top front perspective view thereof, with the front grille attached.

**1 Claim, 2 Drawing Sheets**

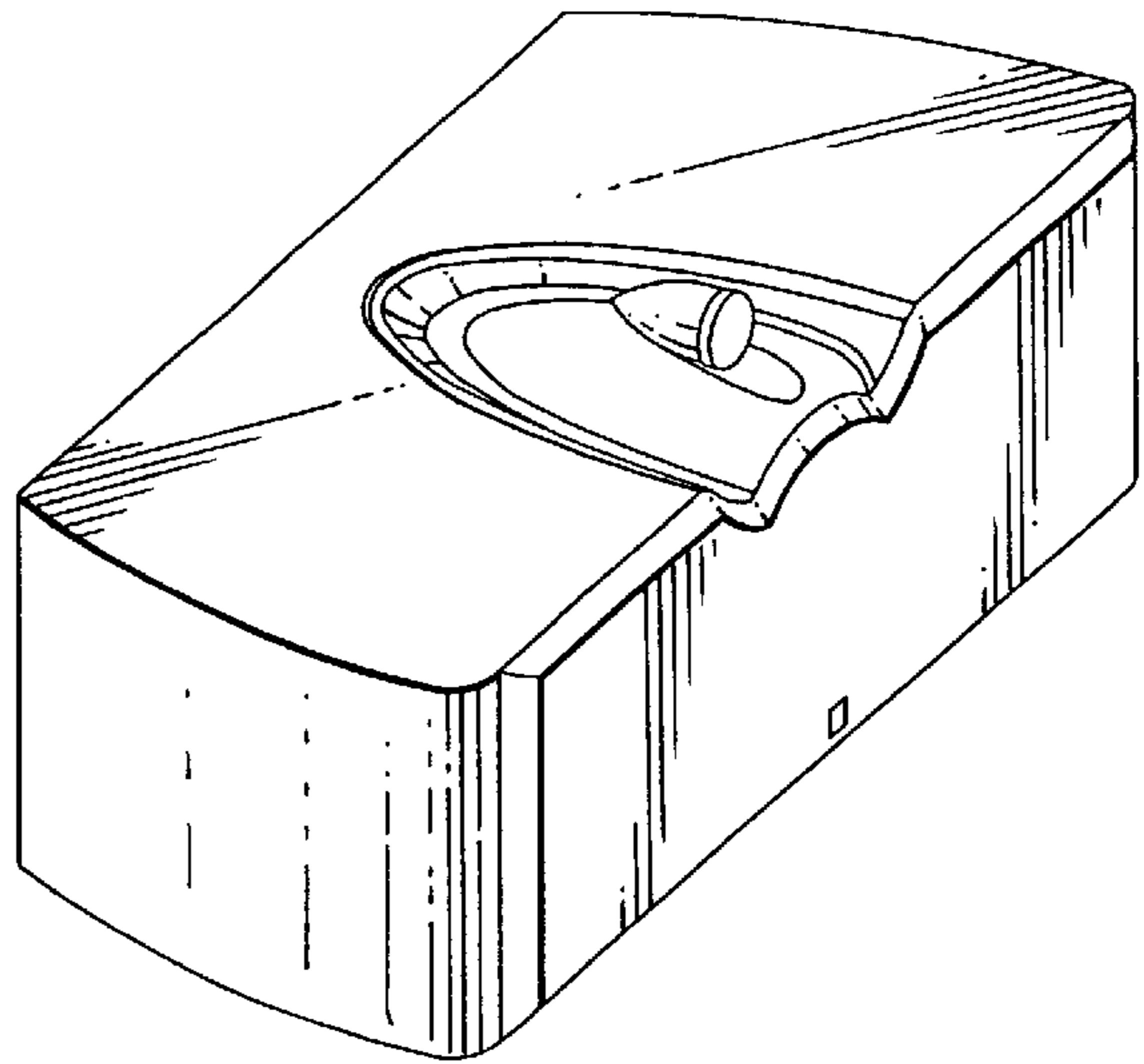
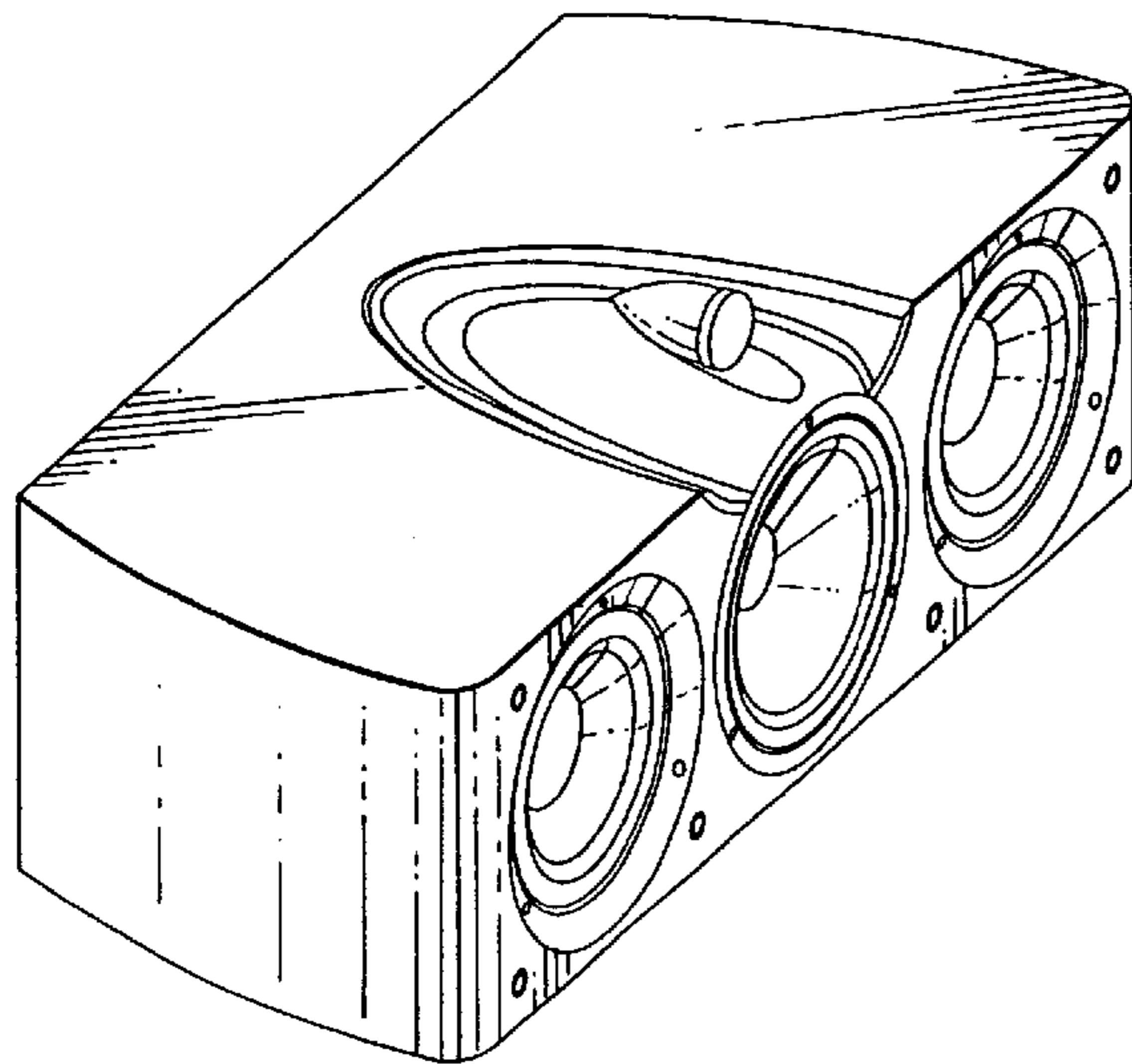

FIG. 1

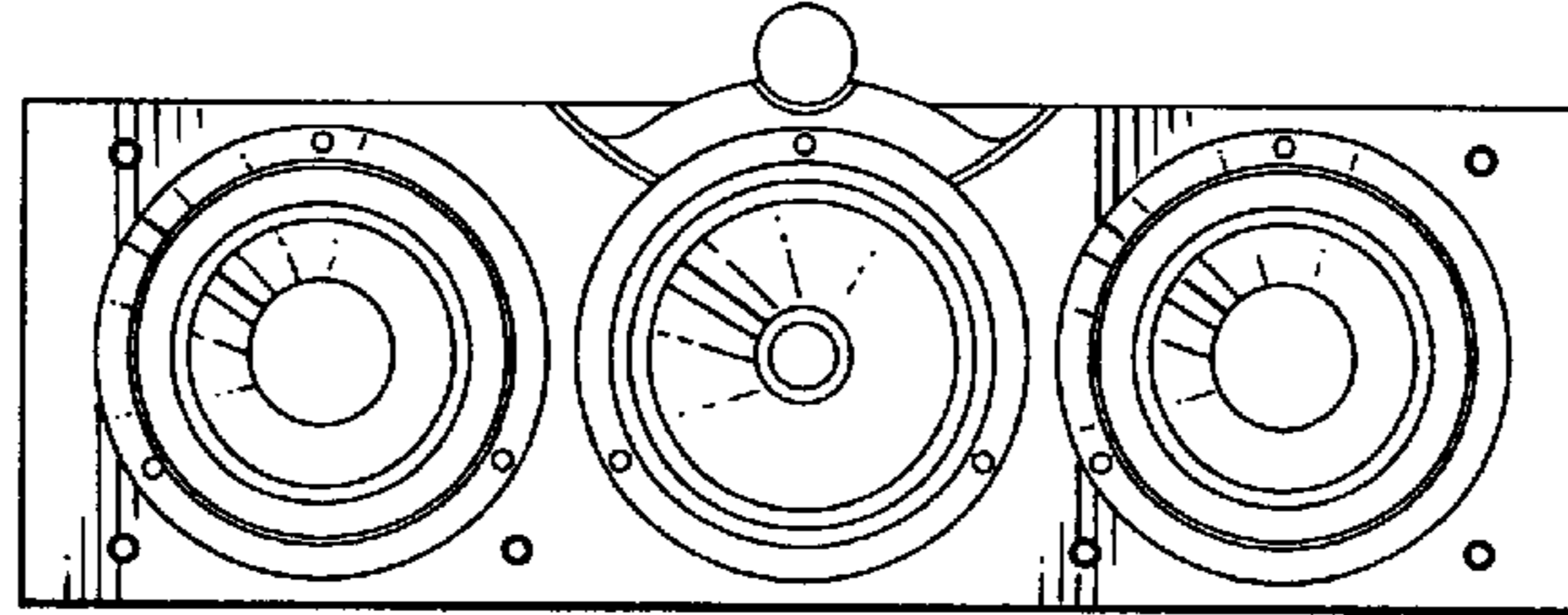

FIG. 2

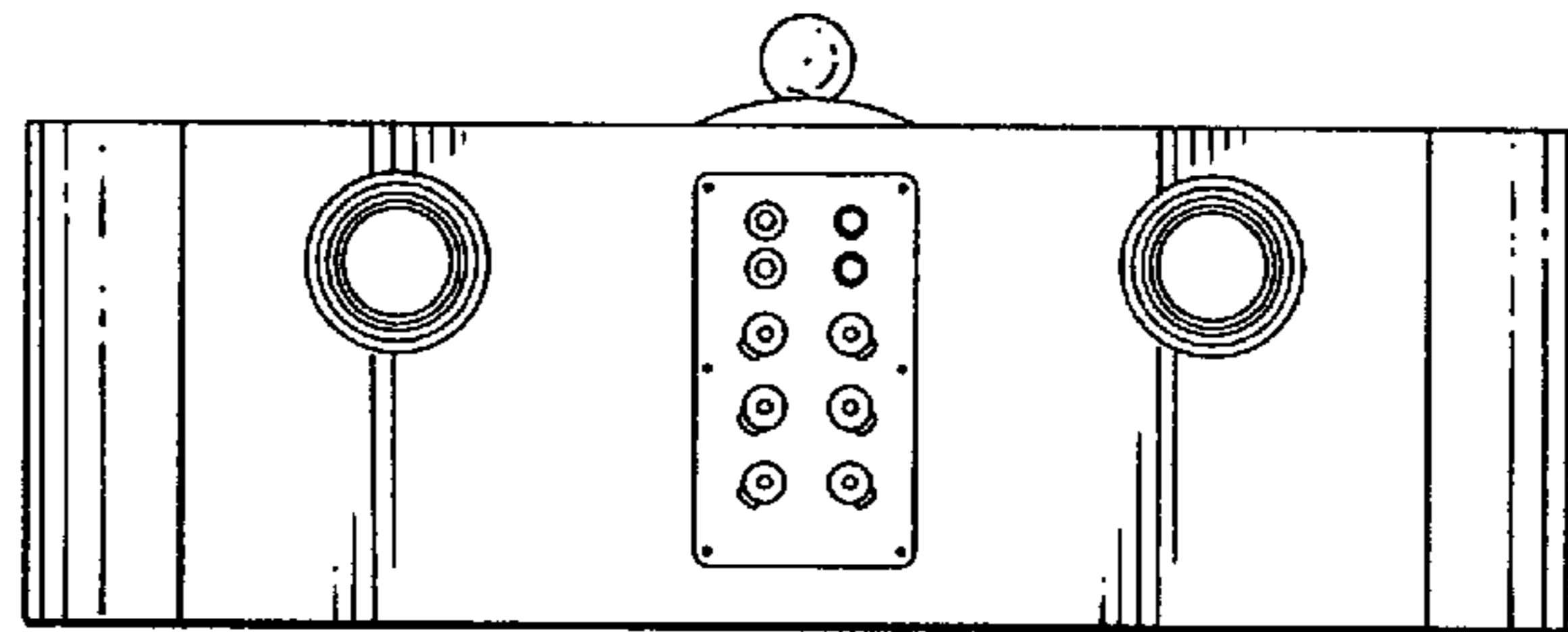

FIG. 3

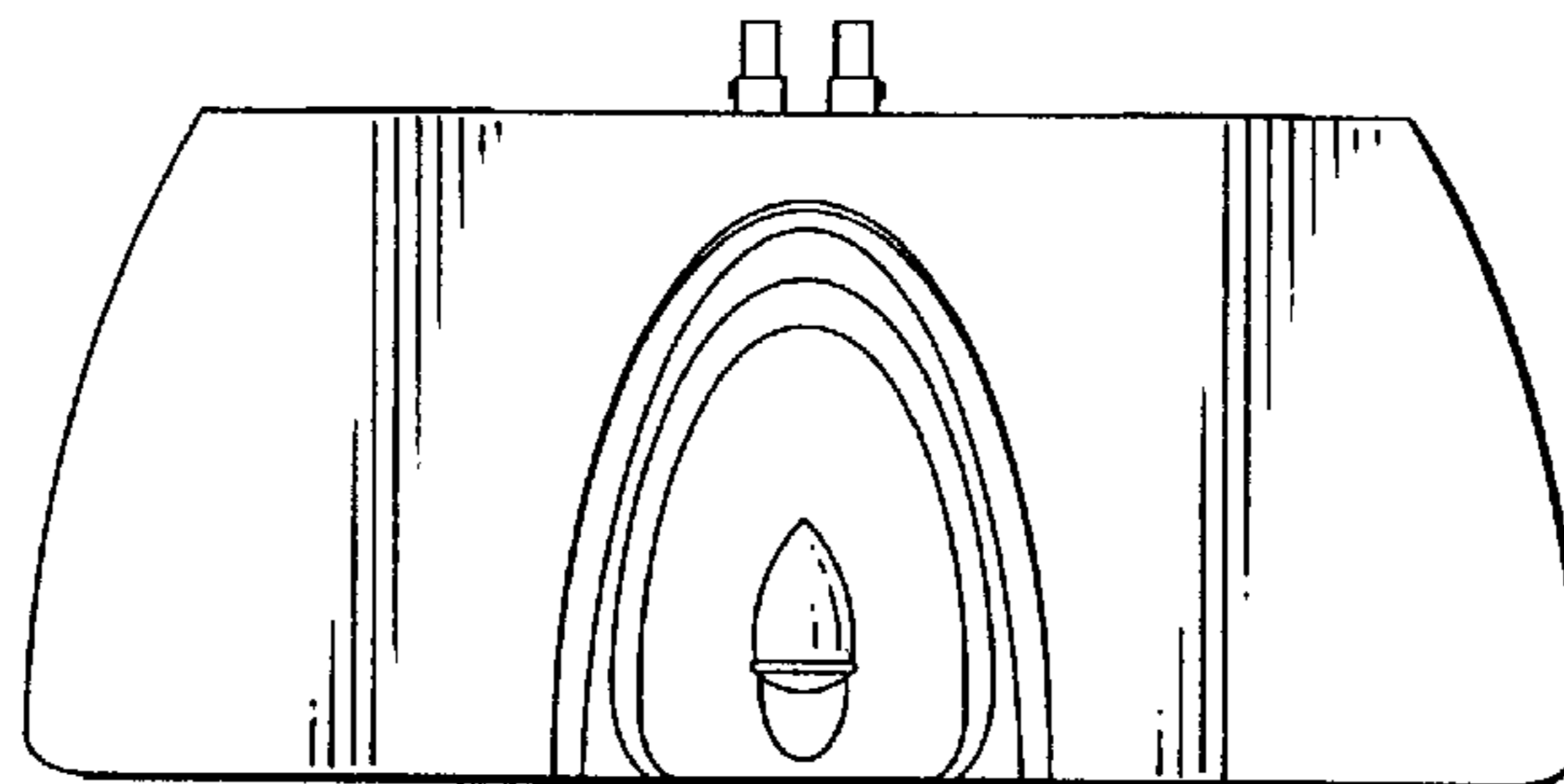

FIG. 4

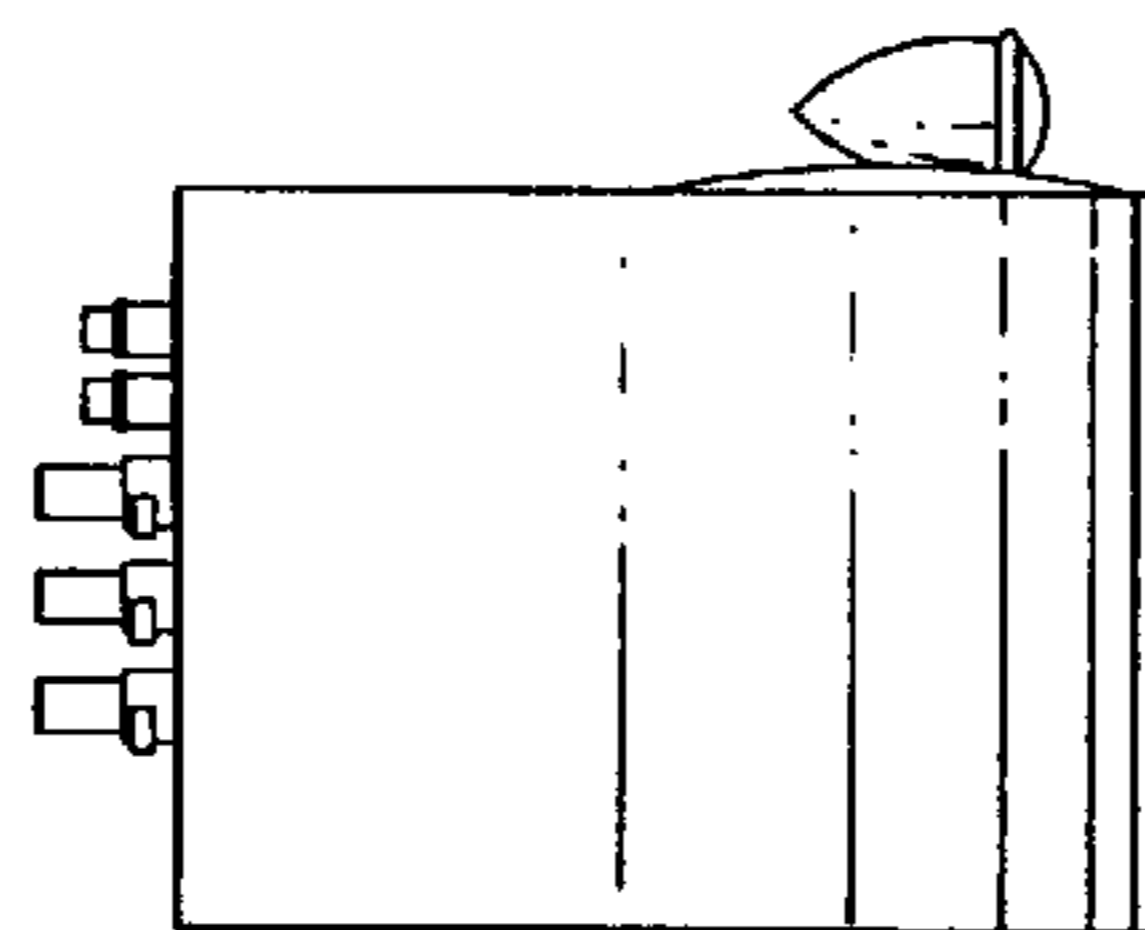

FIG. 5

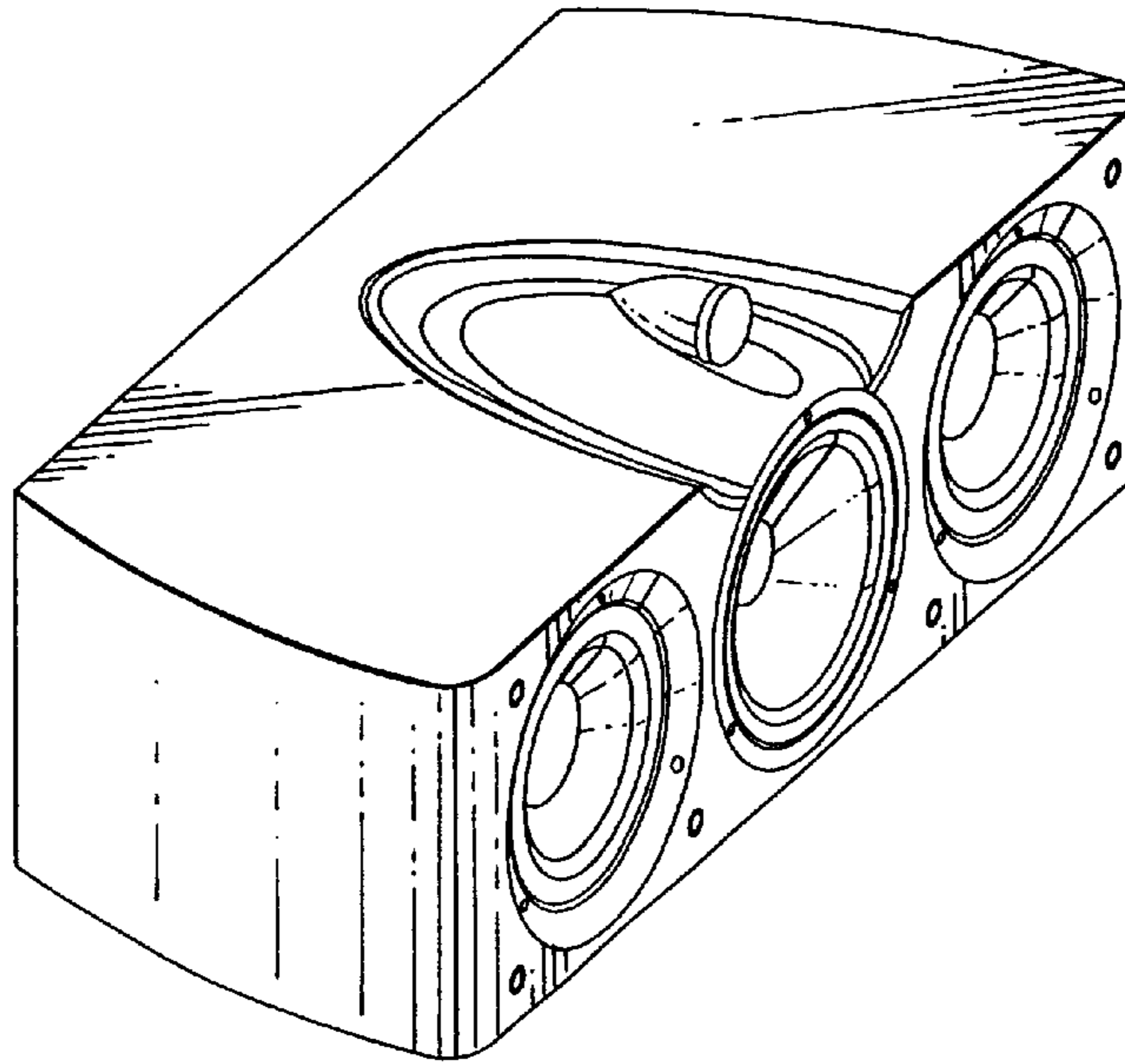

FIG. 6

