



US00D485523S

(12) **United States Design Patent**
Takechi

(10) **Patent No.:** **US D485,523 S**

(45) **Date of Patent:** **** Jan. 20, 2004**

(54) **VEHICLE WHEEL**

(75) Inventor: **Toshinori Takechi**, Matsuyama (JP)

(73) Assignee: **Takechi Project Co., Ltd.** (JP)

(**) Term: **14 Years**

(21) Appl. No.: **29/161,946**

(22) Filed: **Jun. 6, 2002**

(30) **Foreign Application Priority Data**

Jan. 10, 2002 (JP) 2002-000377

(51) **LOC (7) Cl.** **12-16**

(52) **U.S. Cl.** **D12/209**

(58) **Field of Search** **D12/204-211;**
301/37.101, 64.101, 65

(56) **References Cited**

PUBLICATIONS

Road & Track magazine, Vehicle Wheel, vol. 12, p. 34, at least as early at Jul. 1999.

Primary Examiner—Stacia Cadmus

(74) *Attorney, Agent, or Firm*—SAIDMAN DesignLaw Group

(57) **CLAIM**

The ornamental design for a vehicle wheel, as shown and described.

DESCRIPTION

FIG. 1 is a perspective view of a vehicle wheel showing my new design;

FIG. 2 is a front elevational view thereof;

FIG. 3 is a rear elevational view thereof;

FIG. 4 is a top plan view thereof;

FIG. 5 is a bottom plan view thereof;

FIG. 6 is a left side elevational view thereof; the right side elevational view being a mirror image thereof; and,

FIG. 7 is a sectional view taken along a line 7—7 shown in FIG. 2.

1 Claim, 7 Drawing Sheets

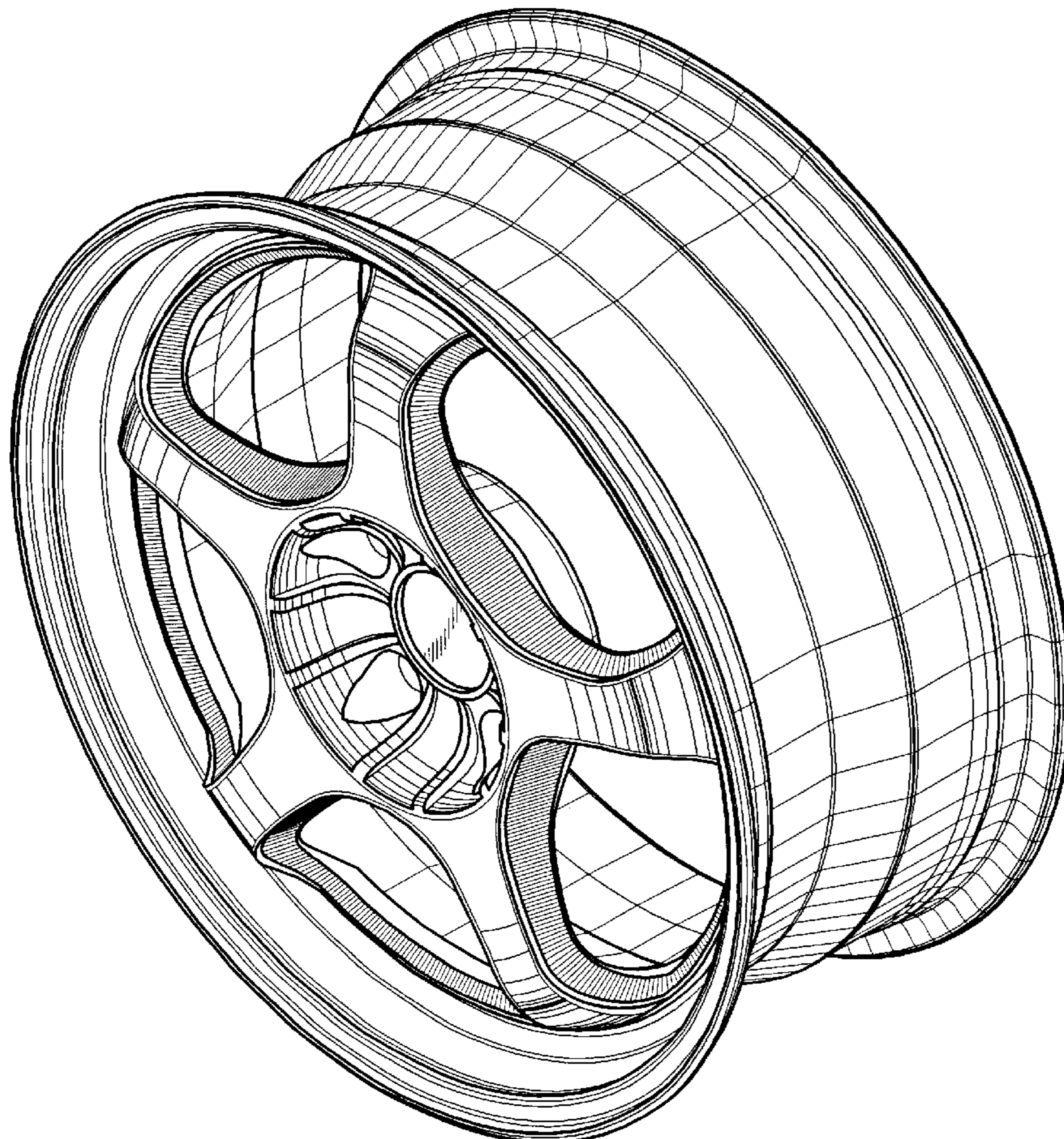

Fig. 1

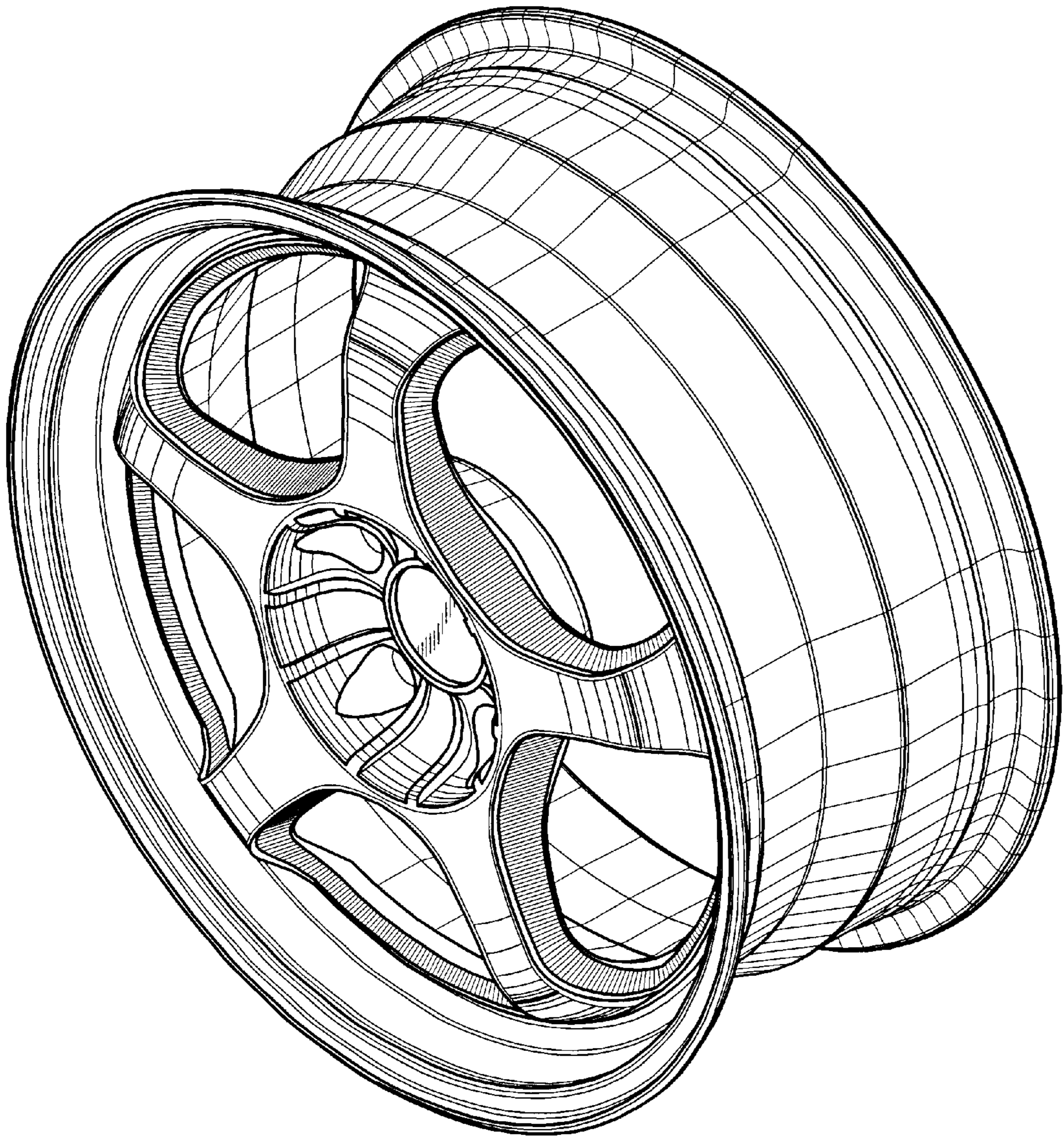

Fig. 2

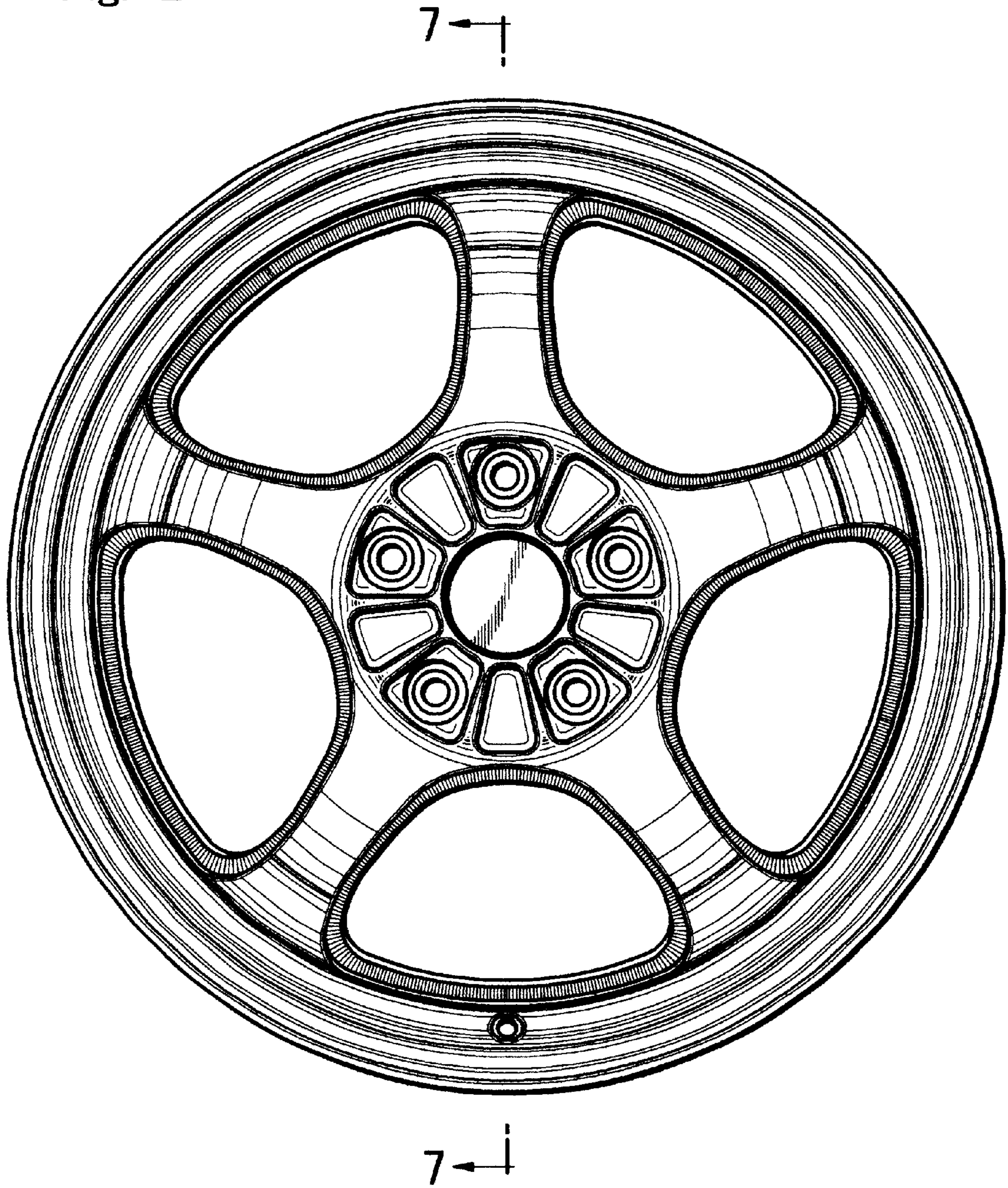

Fig. 3

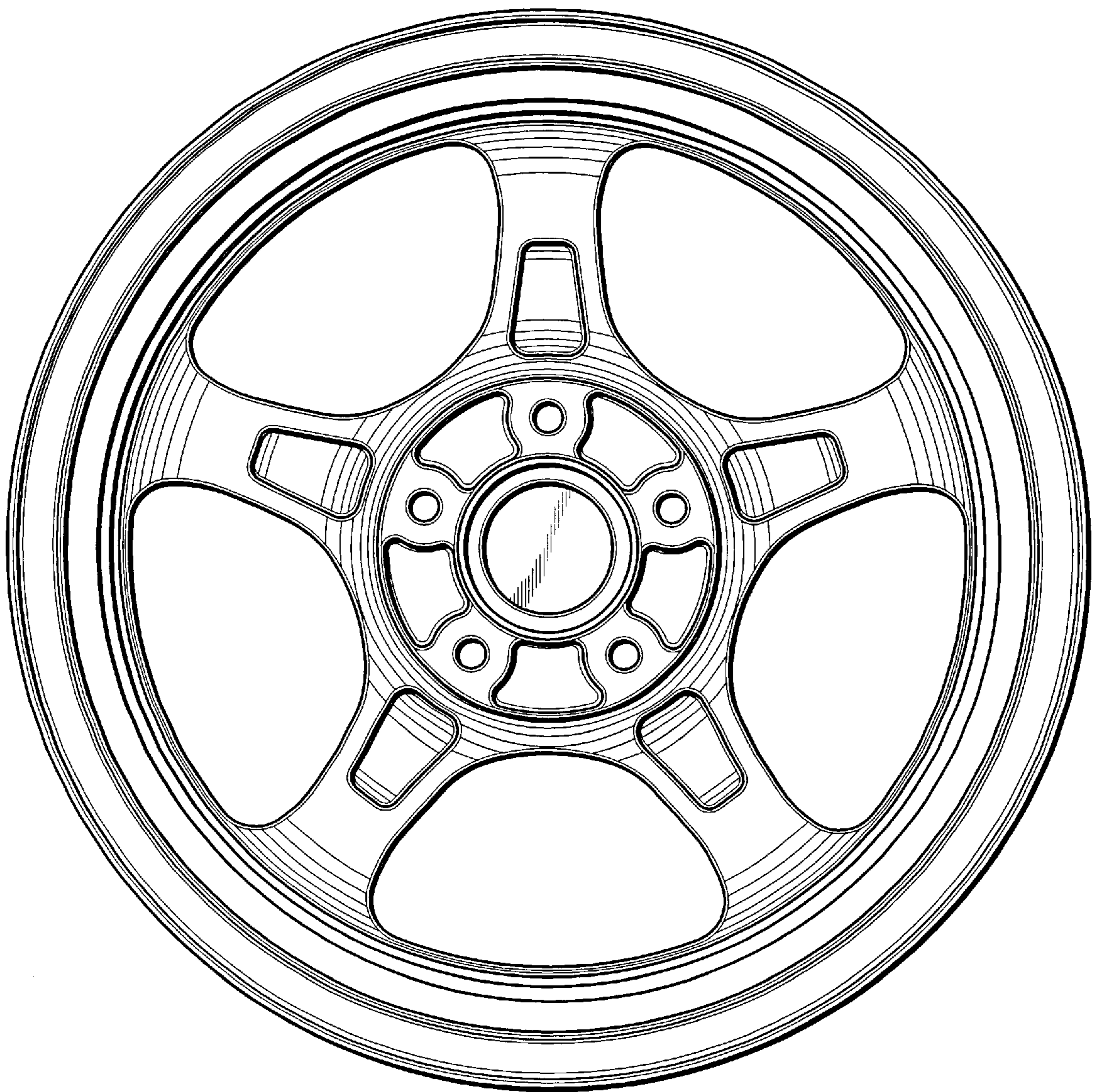

Fig. 4

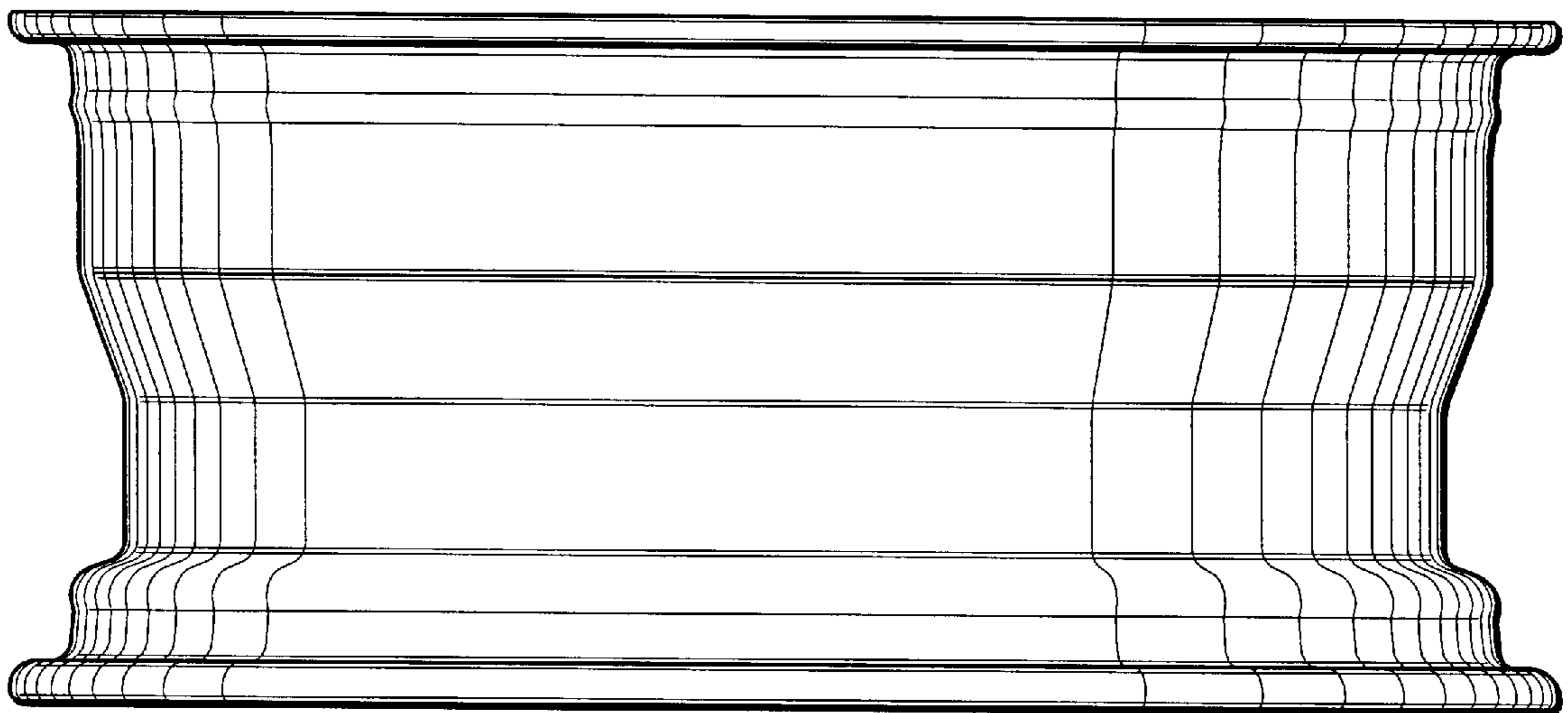

Fig. 5

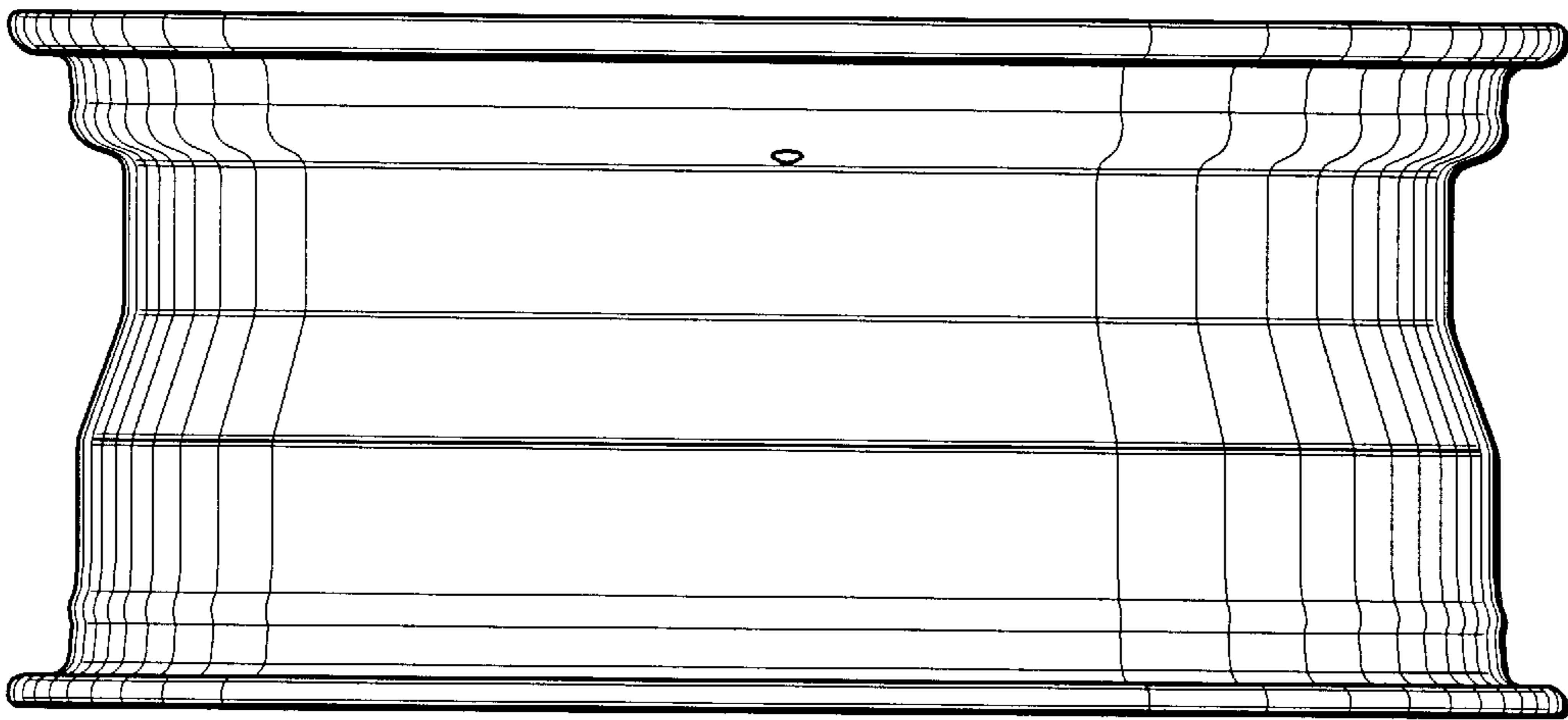

Fig. 6

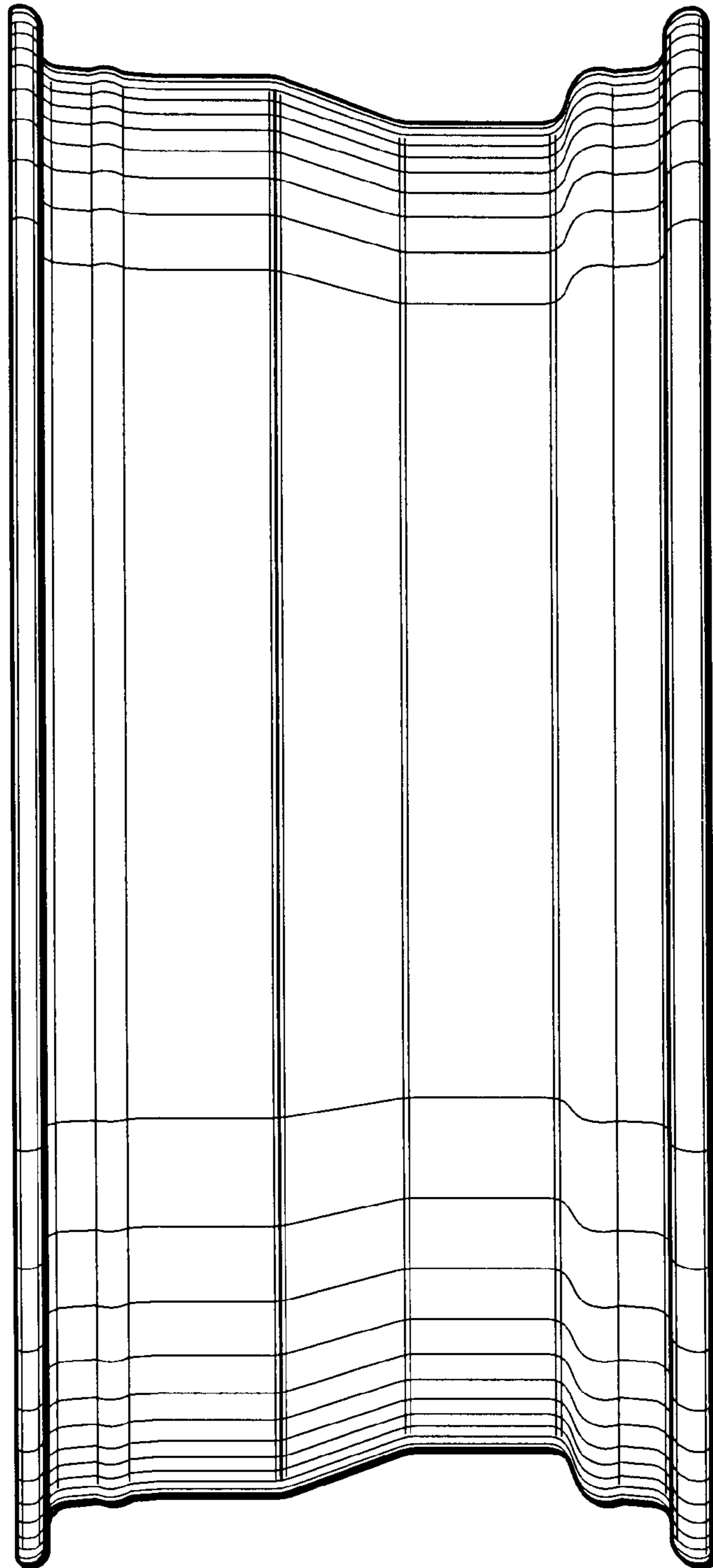

Fig. 7

