



US00D485514S

(12) **United States Design Patent**
Berg

(10) **Patent No.:** **US D485,514 S**

(45) **Date of Patent:** **** Jan. 20, 2004**

(54) **THREE-WHEELED HUMAN POWERED VEHICLE**

(76) Inventor: **Charles Michael Berg**, 11400
Dogwood St., NW., Coon Rapids, MN
(US) 55448

(**) Term: **14 Years**

(21) Appl. No.: **29/168,636**

(22) Filed: **Oct. 5, 2002**

(51) **LOC (7) Cl.** **12-11**

(52) **U.S. Cl.** **D12/112**

(58) **Field of Search** D12/112; 280/259,
280/263, 265, 267, 270, 288.1, 282

(56) **References Cited**

U.S. PATENT DOCUMENTS

4,497,502 A * 2/1985 Forbes et al. 280/282

5,568,935 A * 10/1996 Mason 280/282

* cited by examiner

Primary Examiner—Alan P. Douglas

Assistant Examiner—Linda Brooks

(74) *Attorney, Agent, or Firm*—Michael A. Mochinski

(57) **CLAIM**

The ornamental design for a three-wheeled human powered vehicle, as shown and described.

DESCRIPTION

FIG. 1 is a rear perspective view of a three-wheeled human powered vehicle;

FIG. 2 is a right side elevational view of the embodiment shown in FIG. 1;

FIG. 3 is a left side elevational view of the embodiment shown in FIG. 1;

FIG. 4 is a front elevational view of the embodiment shown in FIG. 1;

FIG. 5 is a rear elevational view of the embodiment shown in FIG. 1;

FIG. 6 is a top plan view of the embodiment shown in FIG. 1; and,

FIG. 7 is a bottom plan view of the embodiment shown in FIG. 1.

1 Claim, 7 Drawing Sheets

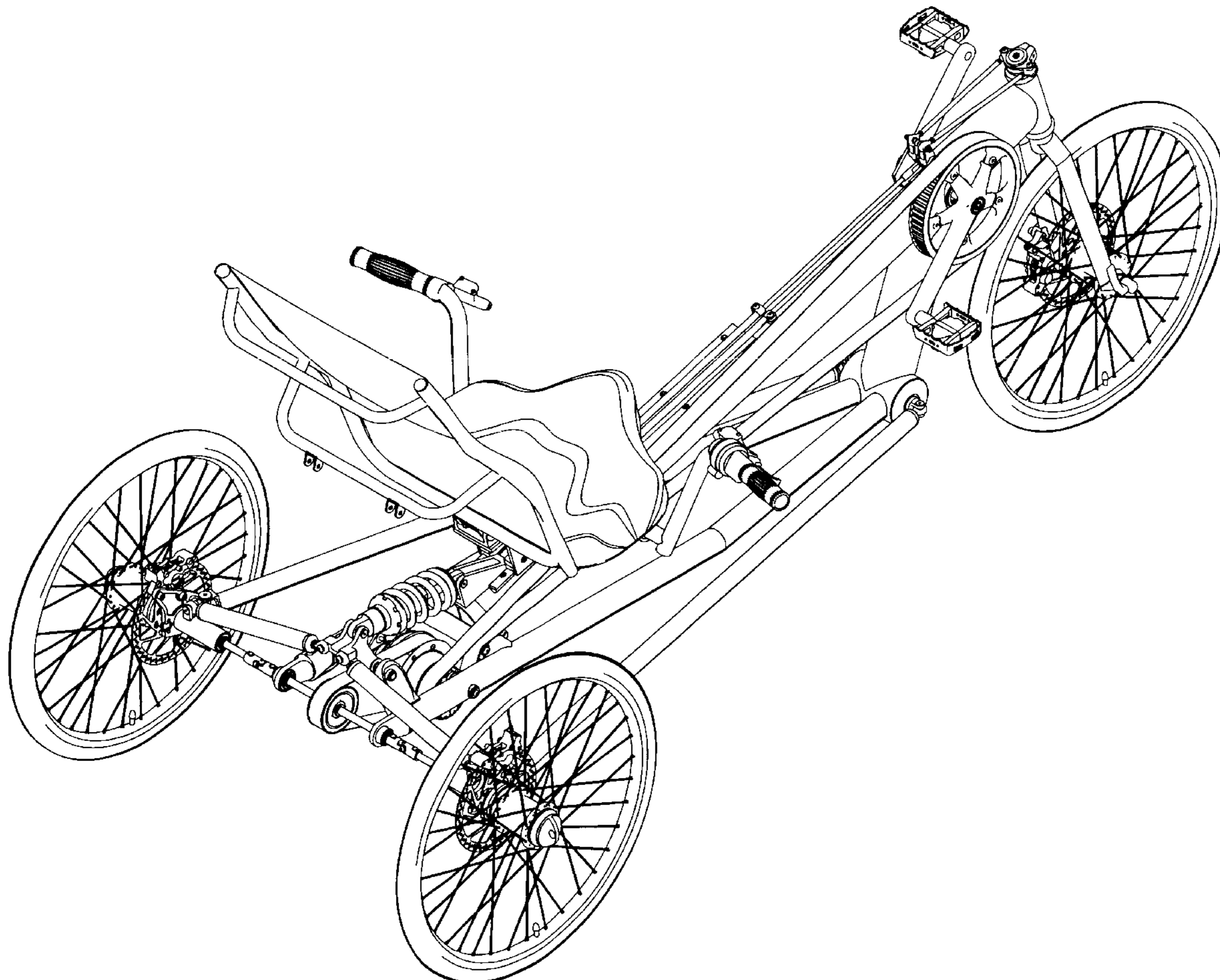

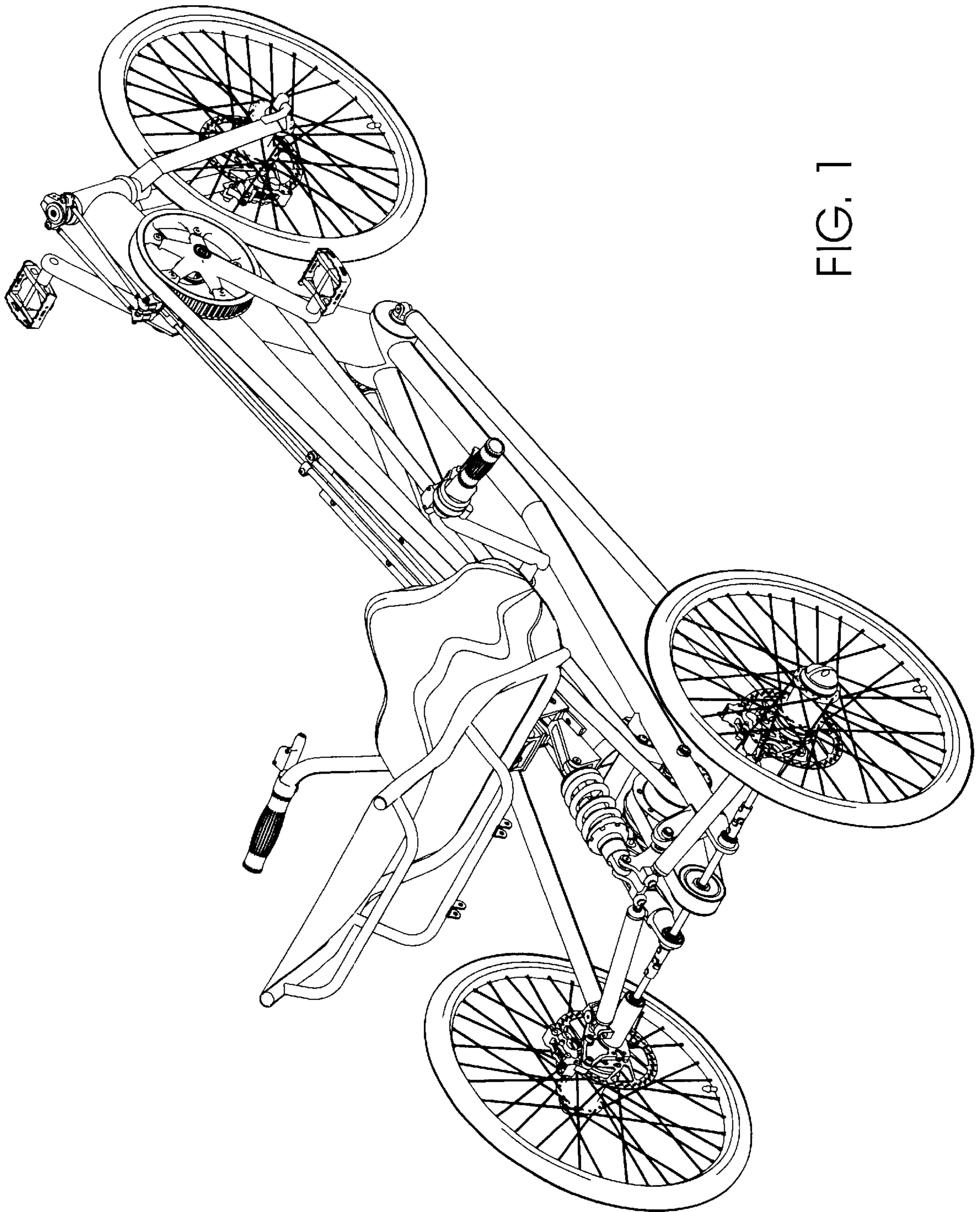

FIG. 1

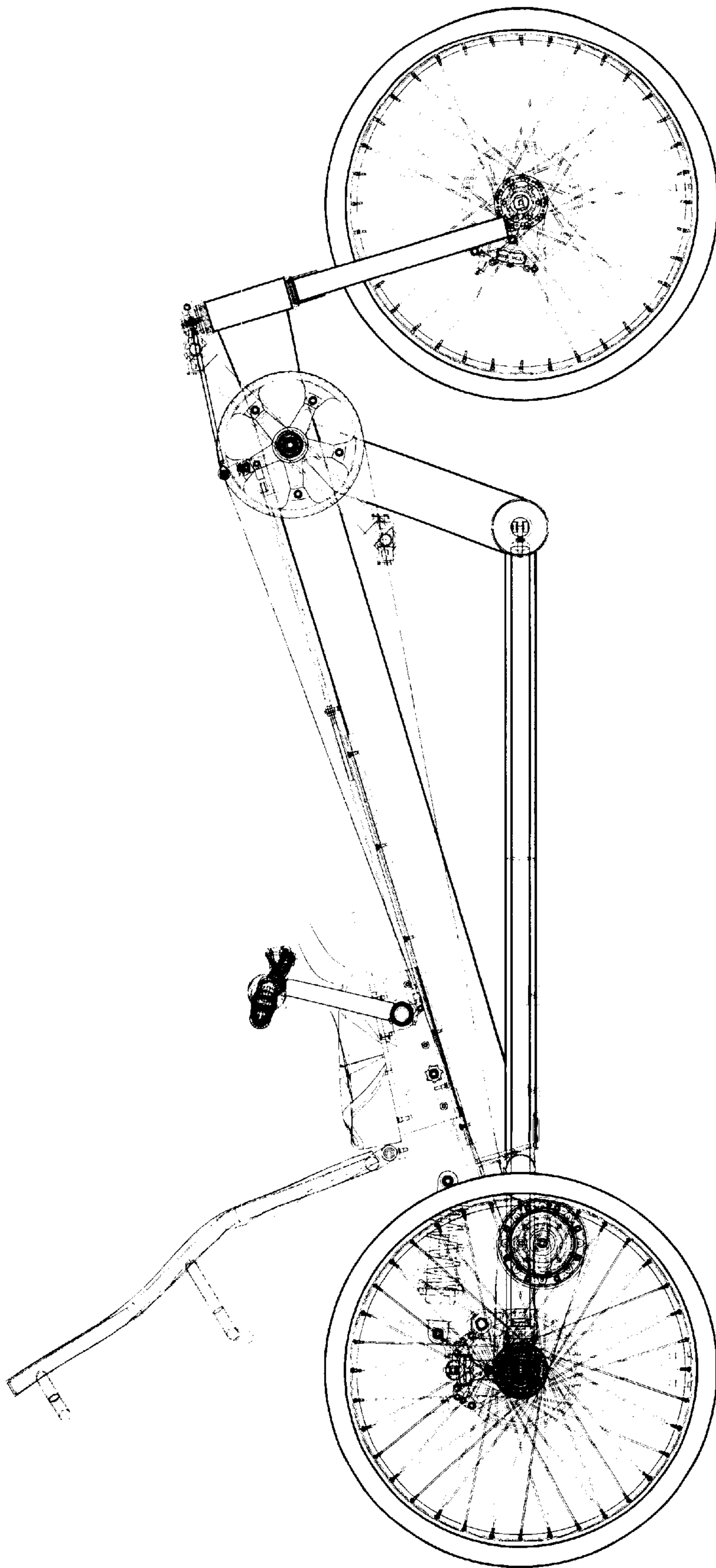

FIG. 2

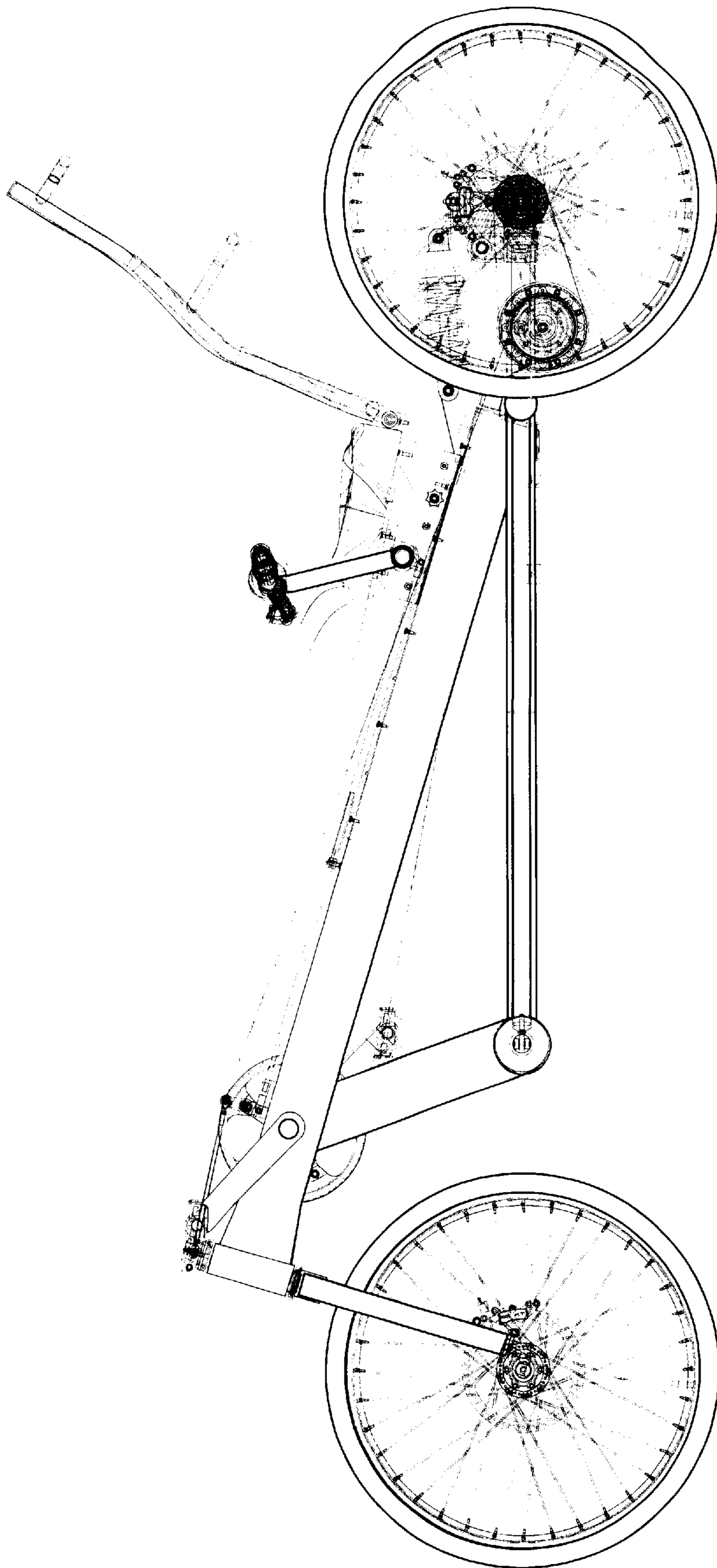

FIG. 3

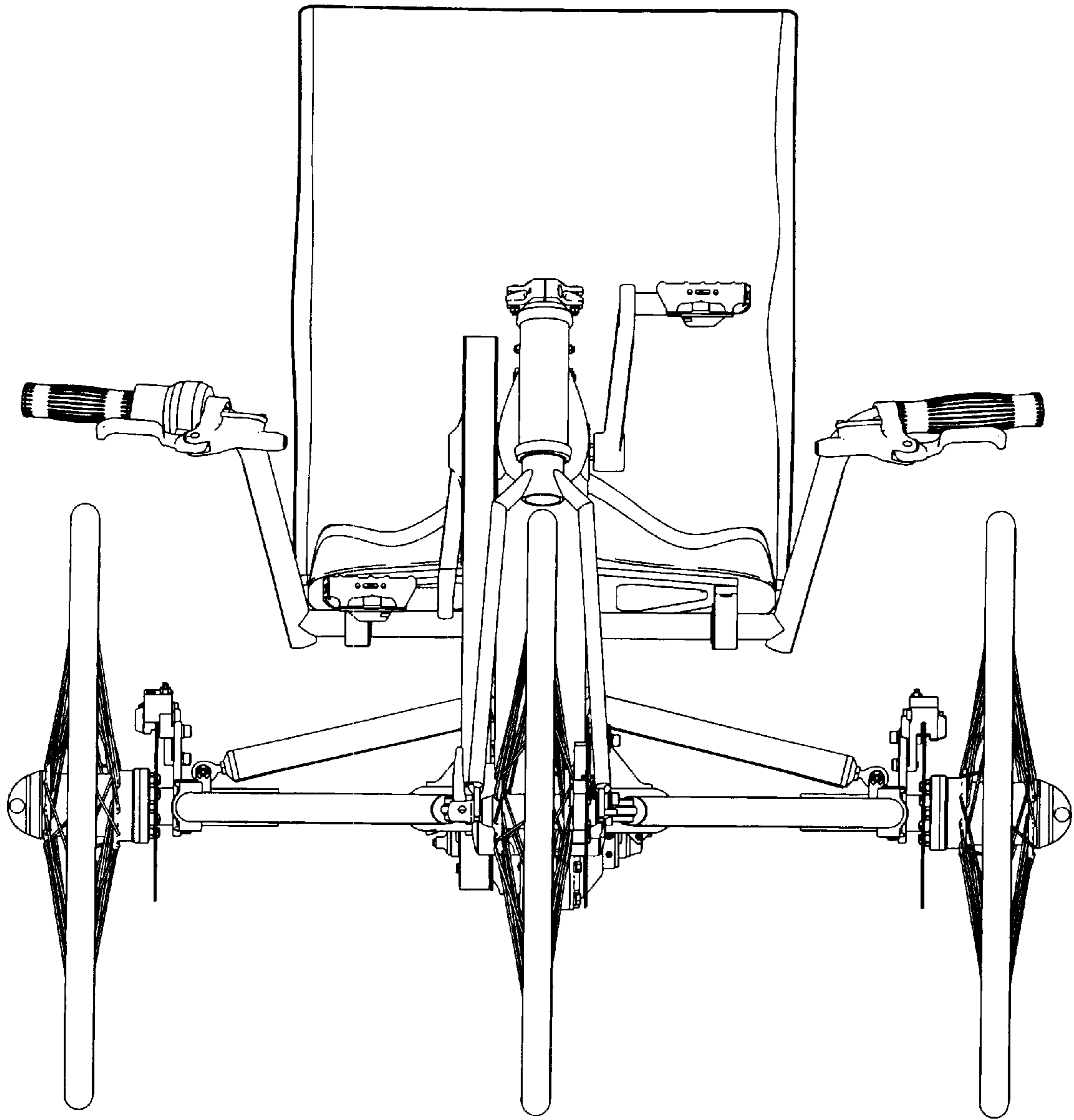

FIG.4

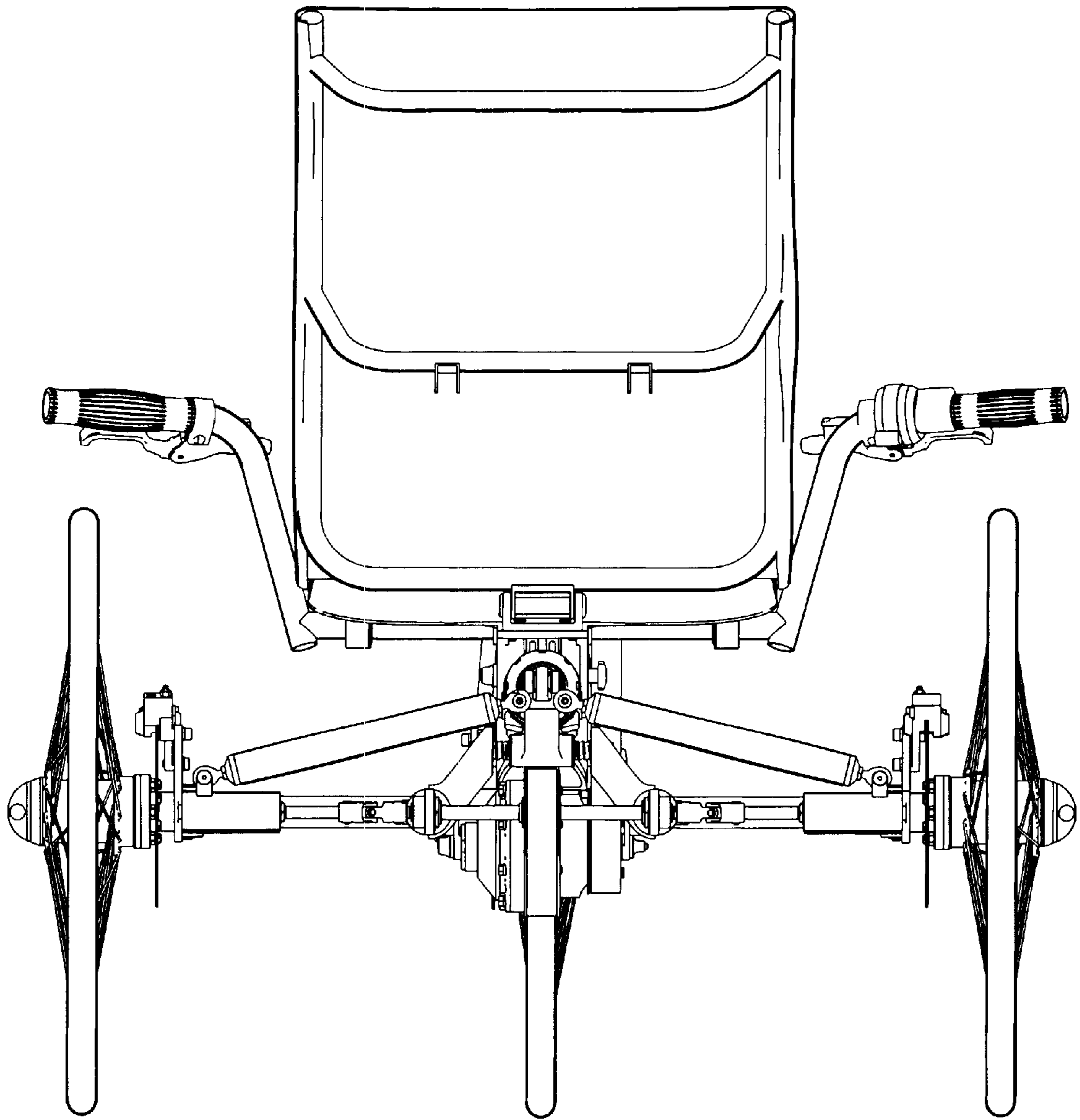

FIG.5

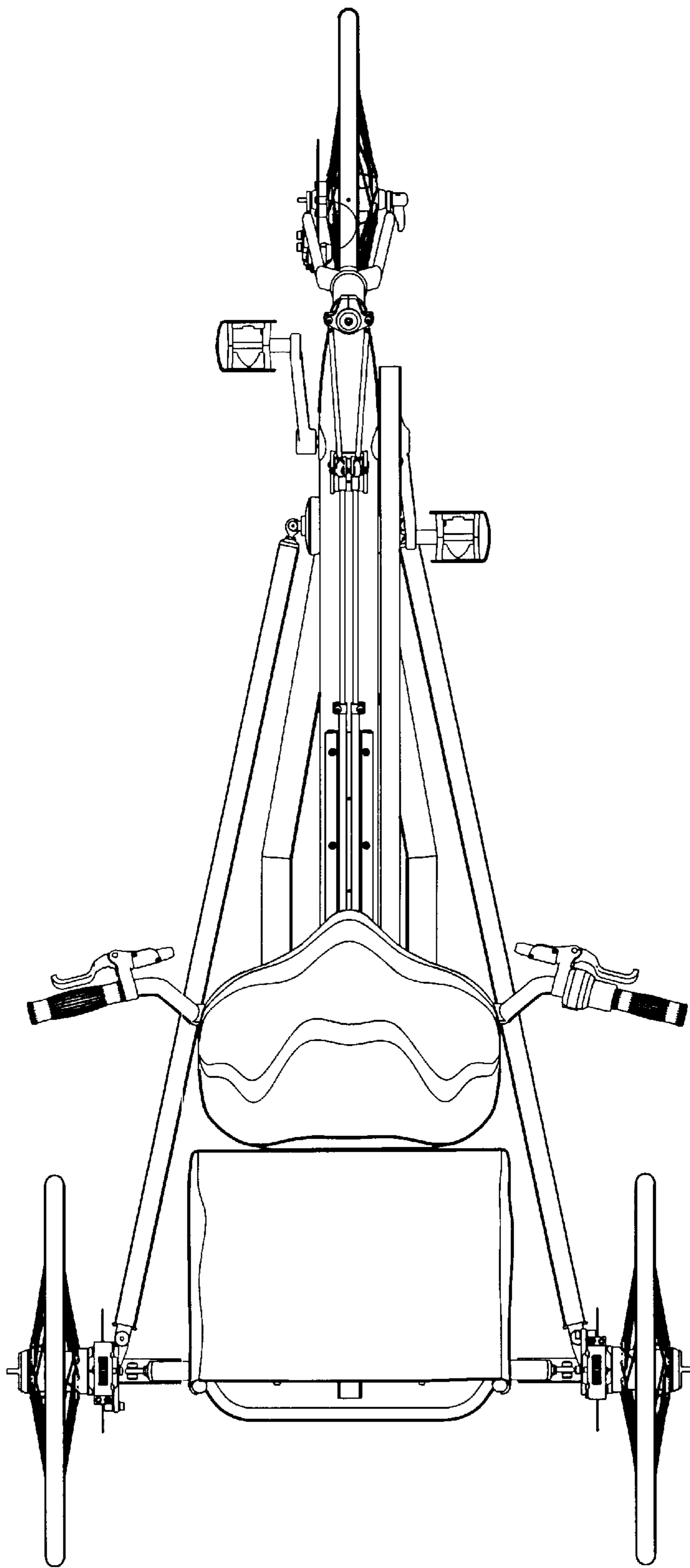

FIG. 6

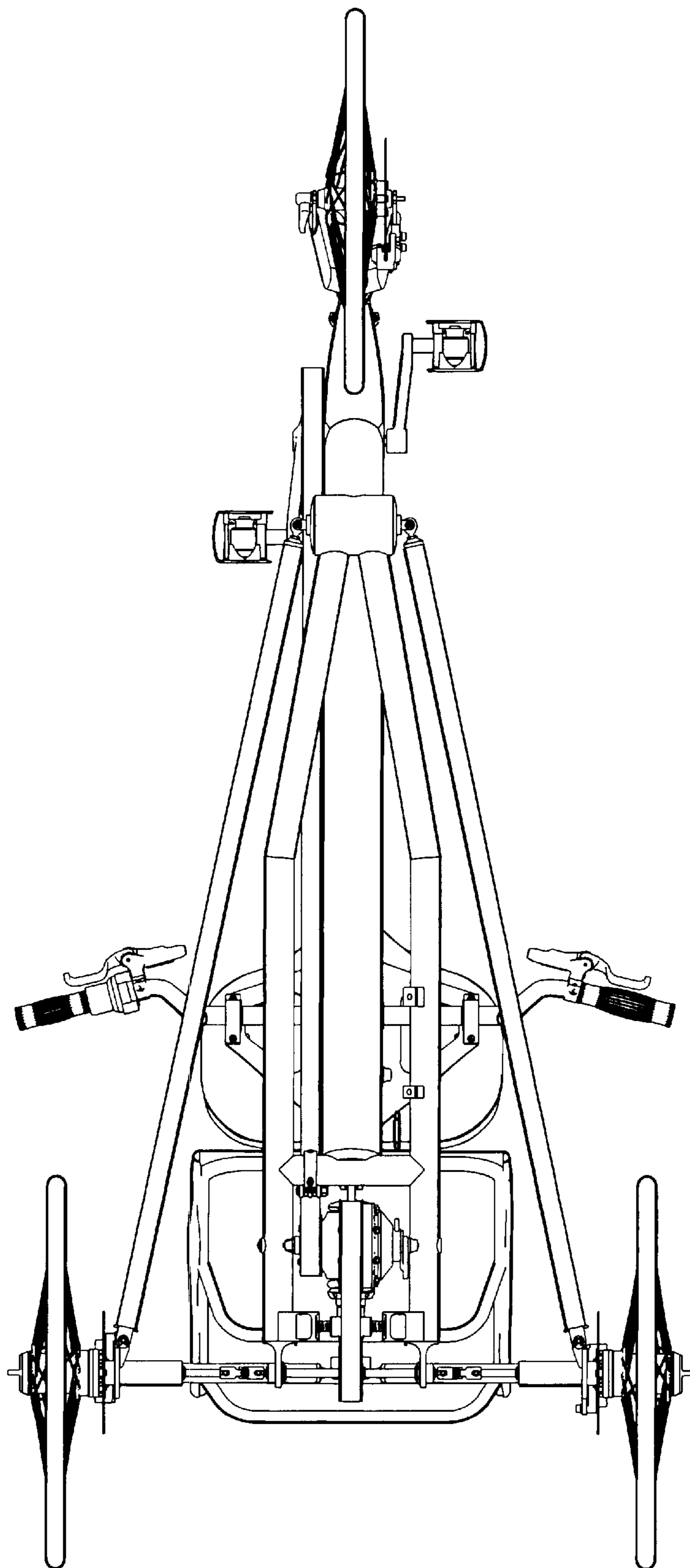

FIG. 7