



US00D485445S

(12) **United States Design Patent**
De Maina

(10) **Patent No.:** **US D485,445 S**

(45) **Date of Patent:** **** Jan. 20, 2004**

(54) **VEHICLE SEATS**

(75) **Inventor:** **Cosimo De Maina**, Alpignano (IT)

(73) **Assignee:** **Petra Italia S.a.s. di Marina Bordo & C.**, Turin (IT)

(**) **Term:** **14 Years**

(21) **Appl. No.:** **29/164,910**

(22) **Filed:** **Jul. 30, 2002**

(30) **Foreign Application Priority Data**

Feb. 1, 2002 (IT) TO200200024

(51) **LOC (7) Cl.** **06-01**

(52) **U.S. Cl.** **D6/356**

(58) **Field of Search** D6/334, 335, 356,
D6/364, 365, 374, 375, 376, 381, 500-502;
297/183.1, 183.7, 183.8, 218.1, 232, 233,
452.12, 452.14

(56) **References Cited**

U.S. PATENT DOCUMENTS

- 3,562,278 A * 2/1971 Barecki 297/218.1
- 3,729,226 A * 4/1973 Barecki 297/232
- D233,868 S * 12/1974 Woodters D6/356
- D233,918 S * 12/1974 Barecki D6/356
- 4,077,664 A * 3/1978 Harder, Jr. 297/183.8

D467,088 S * 12/2002 Haney et al. D6/356

* cited by examiner

Primary Examiner—Doris V. Coles

Assistant Examiner—Mimosa De

(74) *Attorney, Agent, or Firm*—Ladas & Parry

(57) **CLAIM**

The designs for vehicle seats, substantially as shown and described.

DESCRIPTION

FIG. 1 is a perspective view of a first embodiment of the vehicle seats showing my new design;
 FIG. 2 is a front view of the FIG. 1 seat;
 FIG. 3 is a rear view of the FIG. 1 seat;
 FIG. 4 is a first side view of the FIG. 1 seat (the other side view is specular with respect to the one shown);
 FIG. 5 is a top plan view of the FIG. 1 seat;
 FIG. 6 is a bottom plan view of the FIG. 1 seat;
 FIG. 7 is a perspective view of a second embodiment of the vehicle seats showing my new design;
 FIG. 8 is a front view of the FIG. 7 seat;
 FIG. 9 is a rear view of the FIG. 7 seat;
 FIG. 10 is a first side view of the FIG. 7 seat (the other side view is specular with respect to the one shown);
 FIG. 11 is a top plan view of the FIG. 7 seat; and,
 FIG. 12 is a bottom plan view of the FIG. 7 seat.

1 Claim, 6 Drawing Sheets

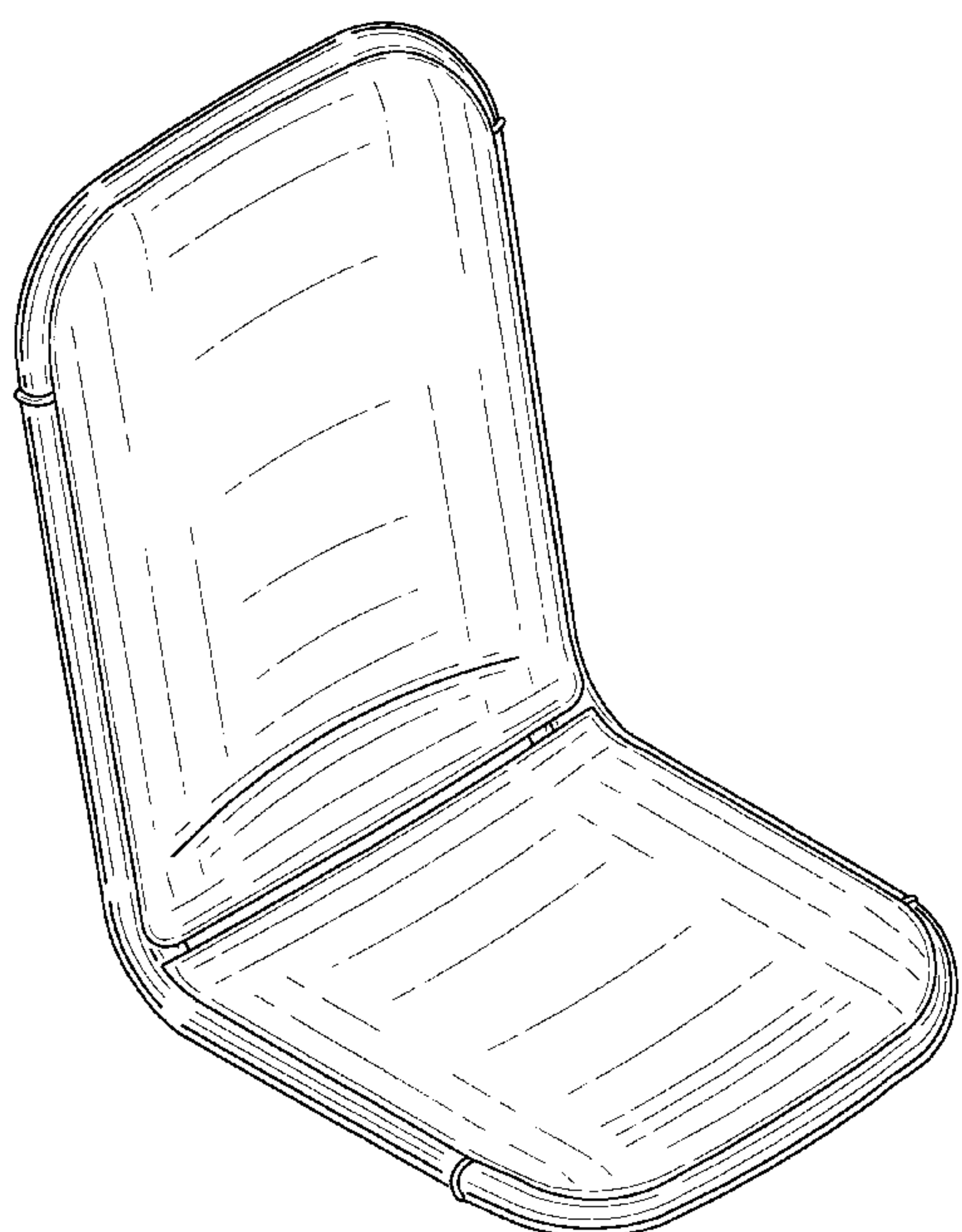

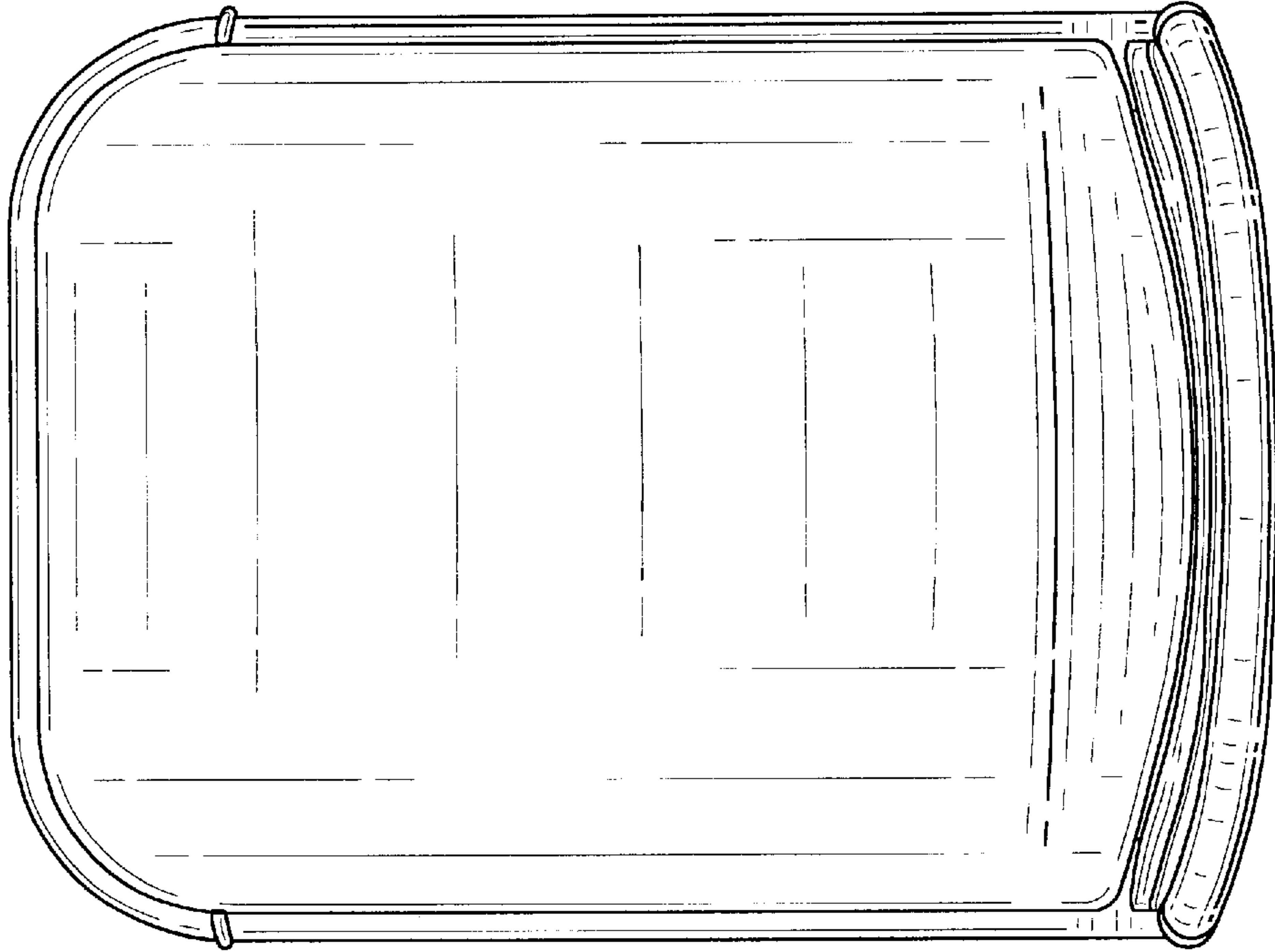

FIG. 2

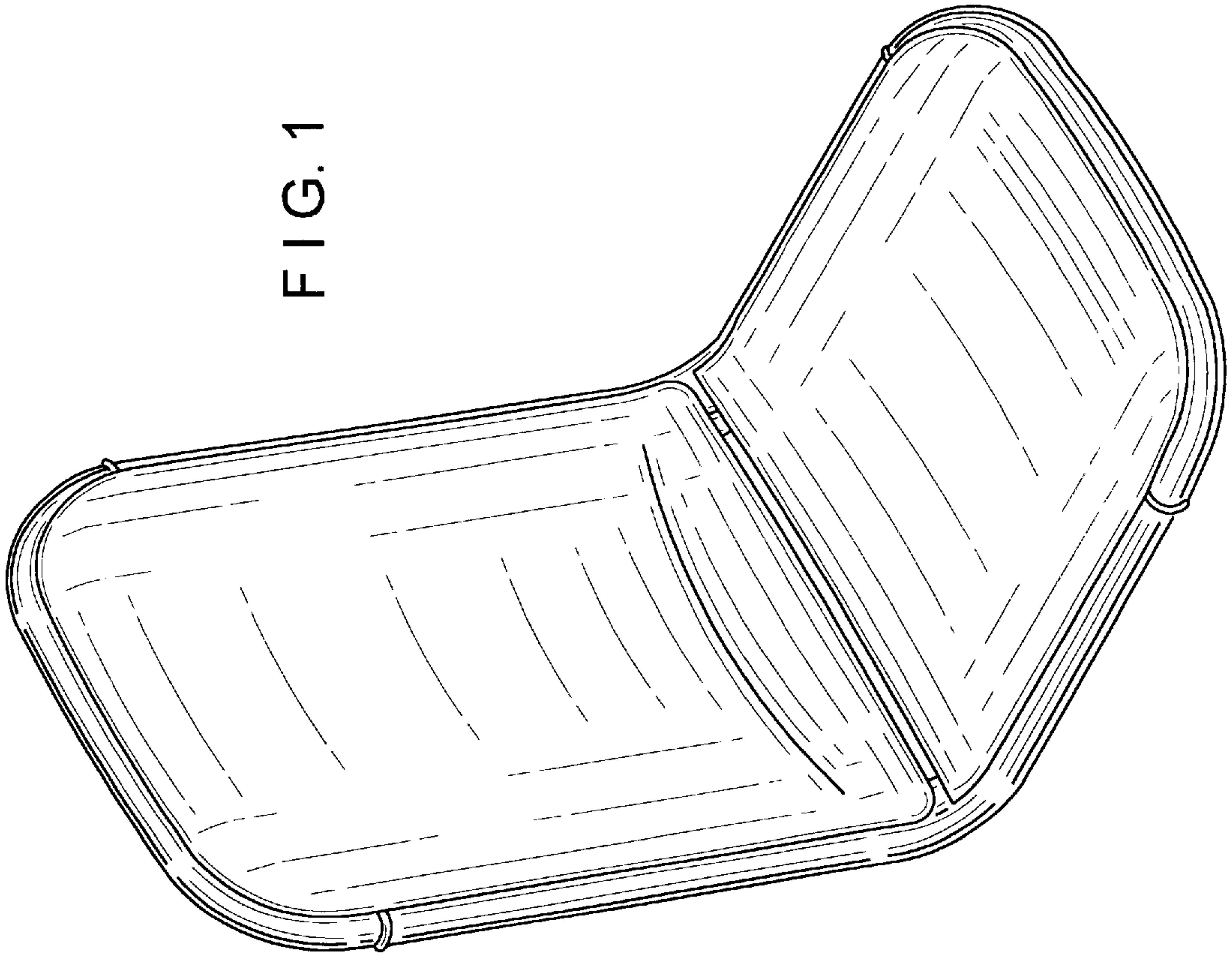

FIG. 1

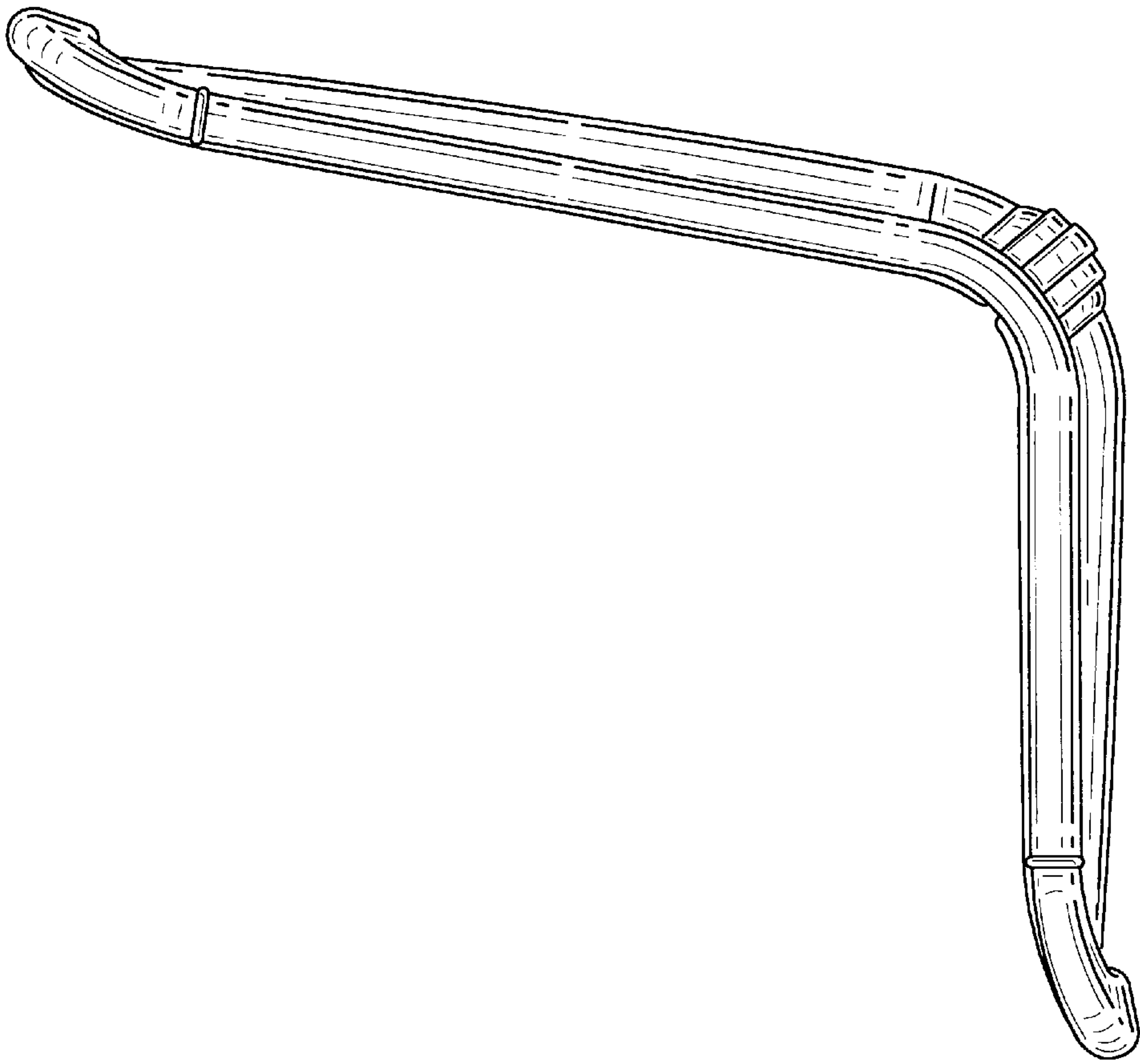

FIG. 4

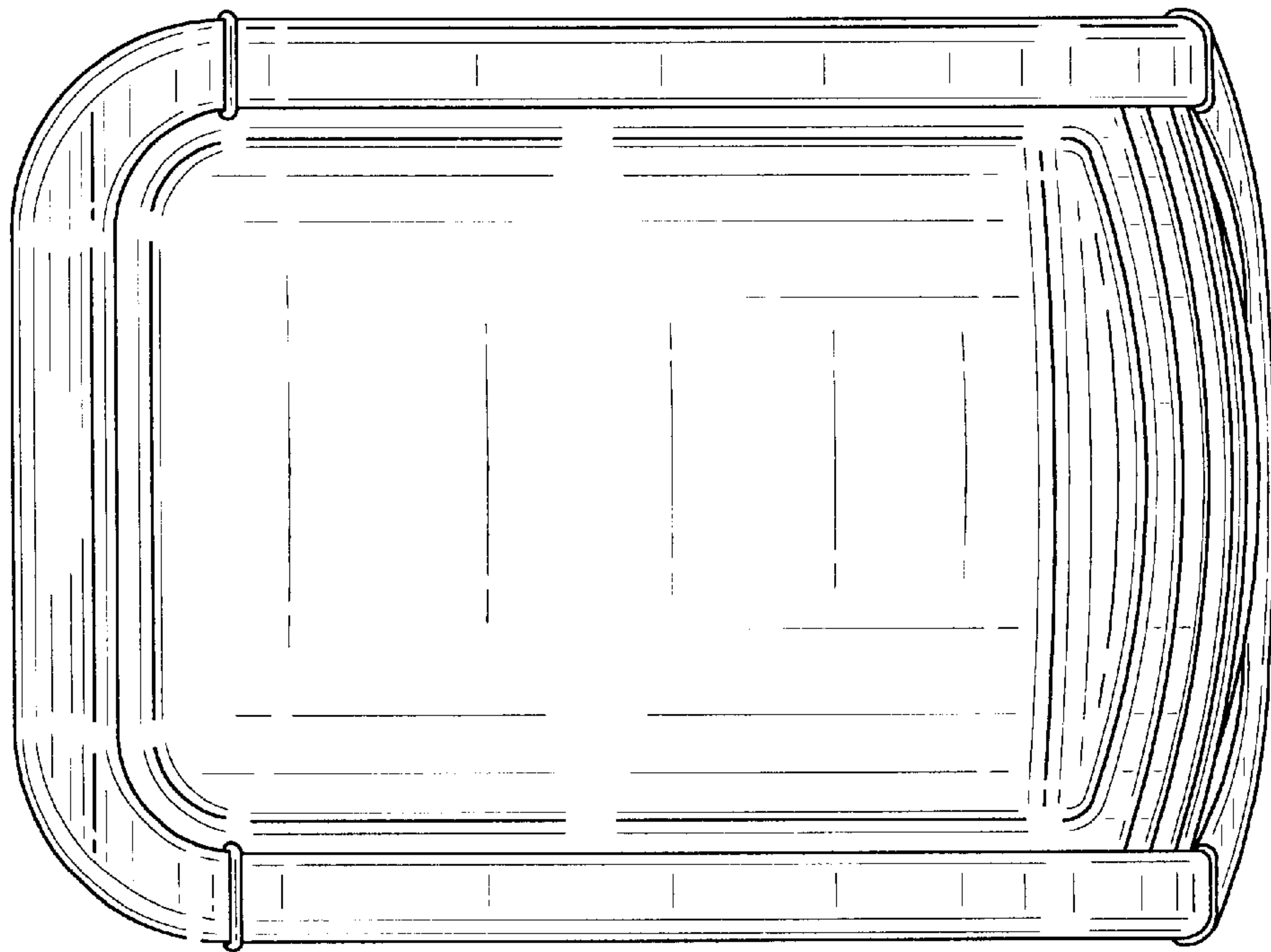

FIG. 3

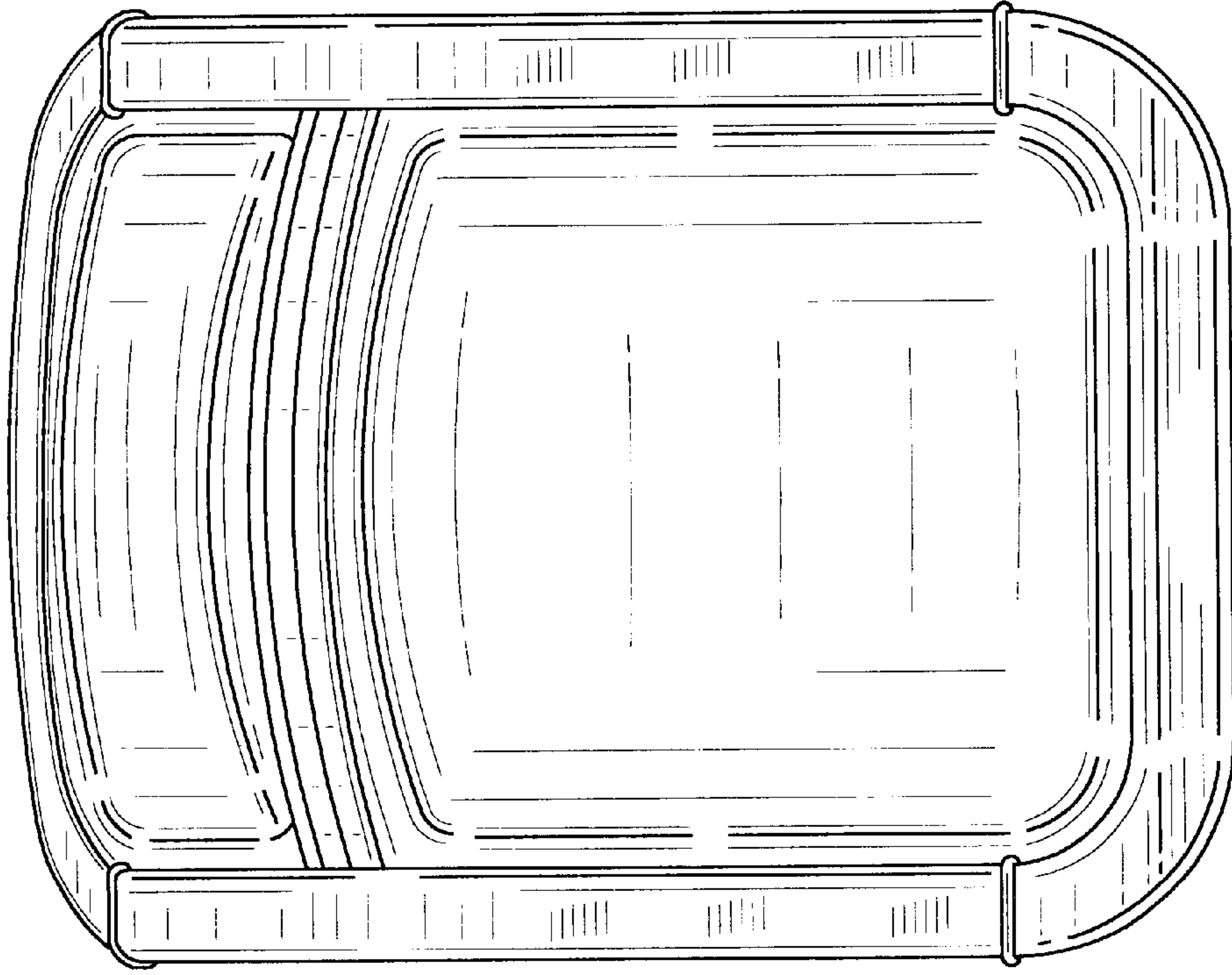

FIG. 6

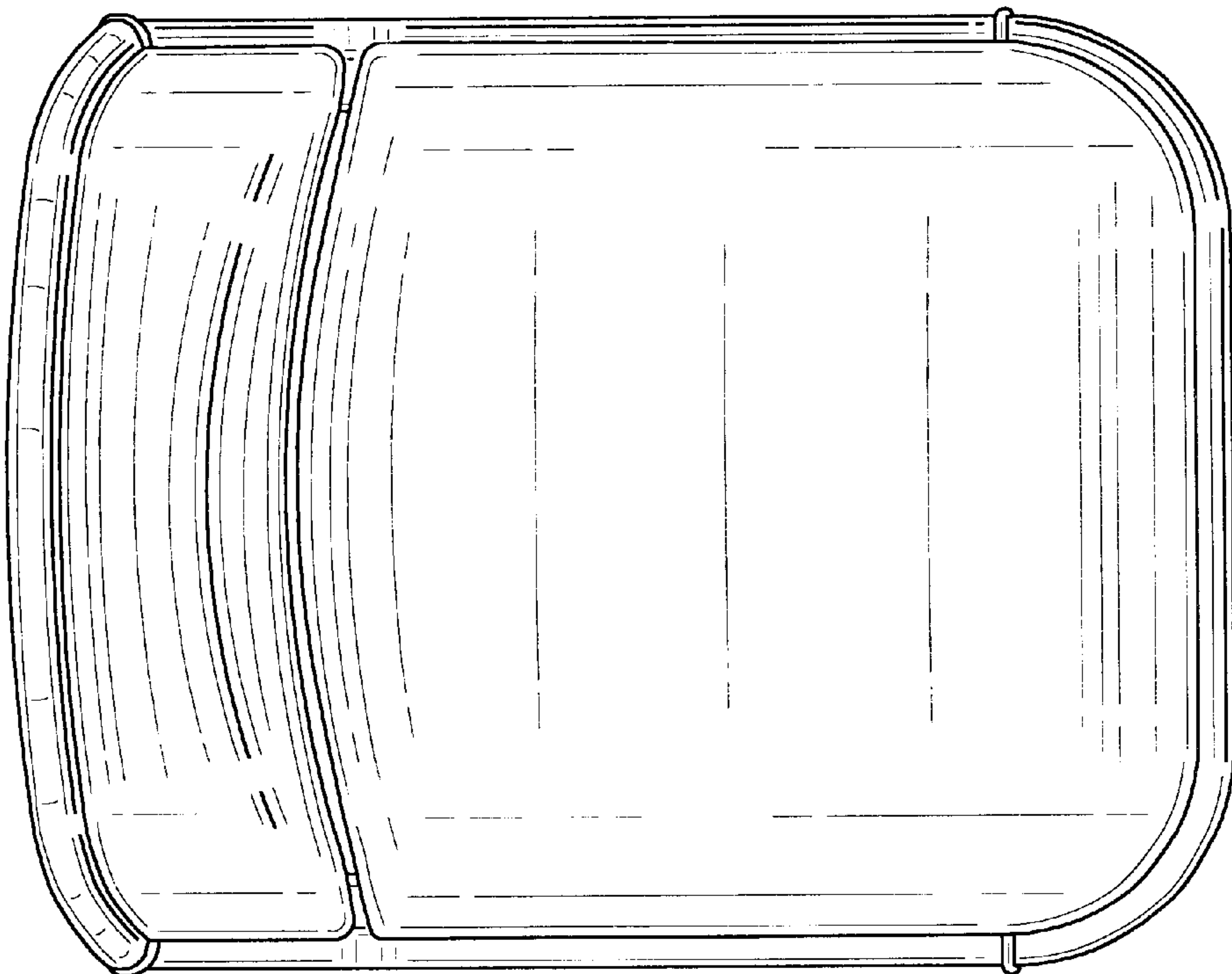

FIG. 5

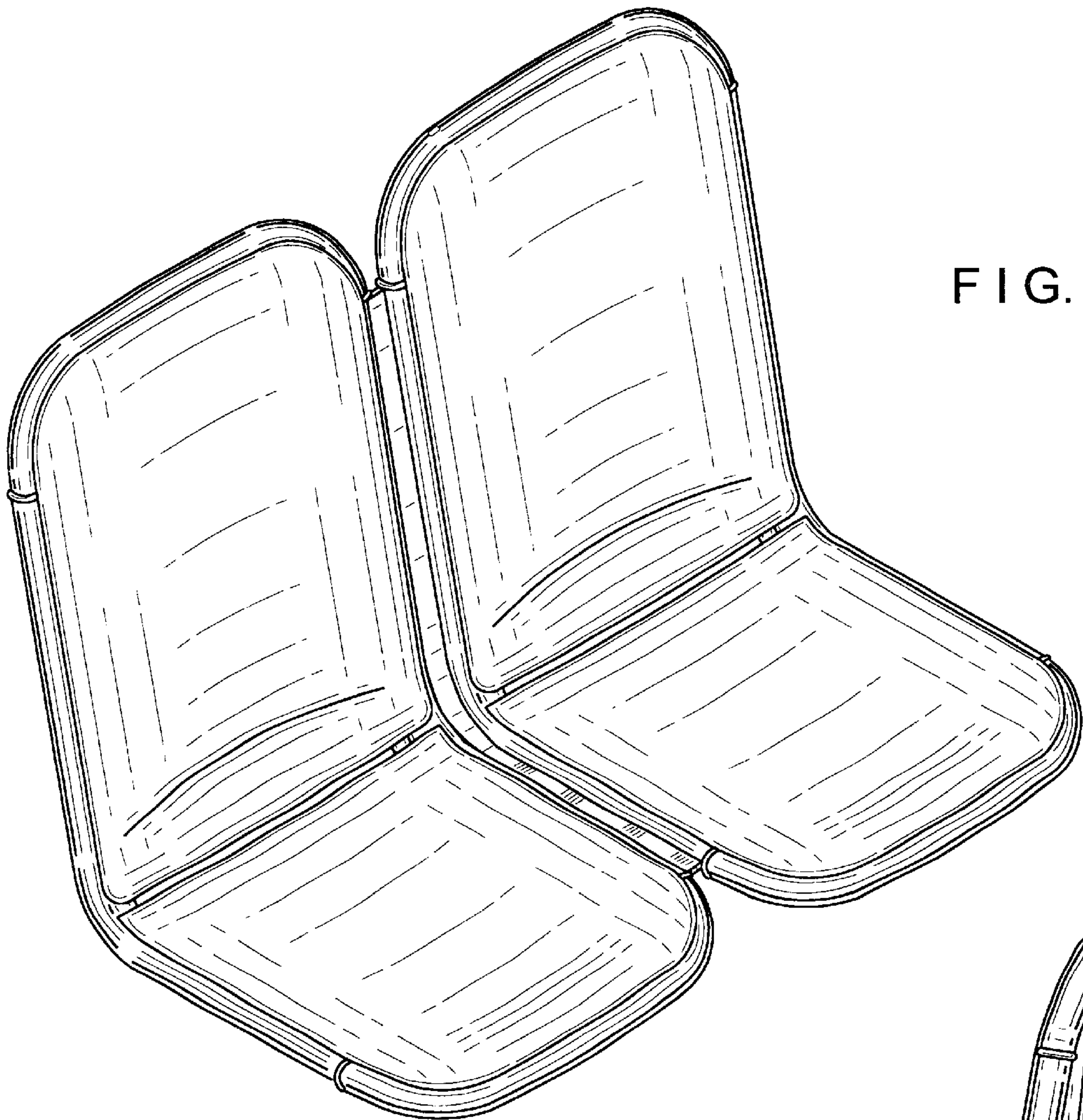
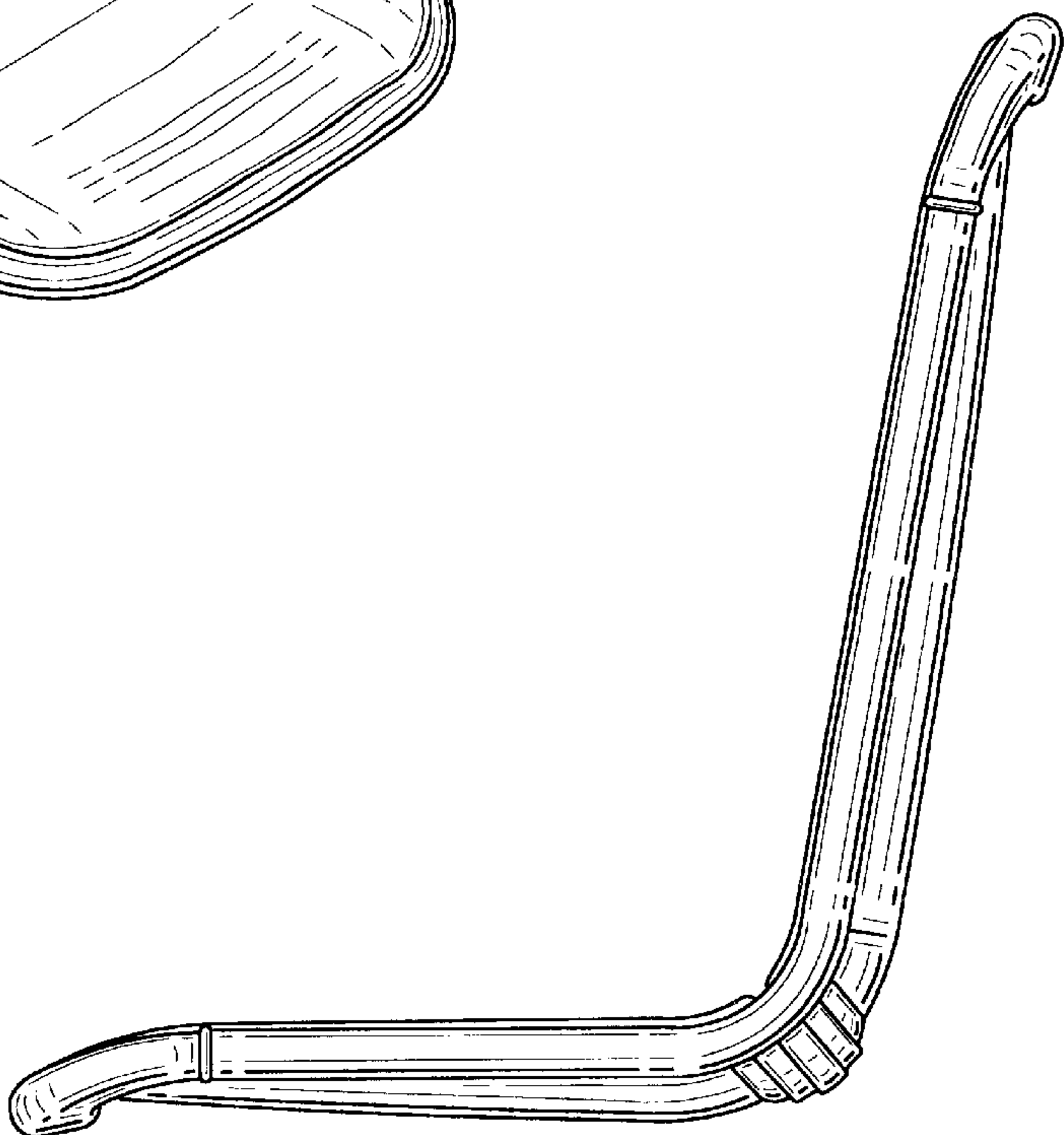

FIG. 7

FIG. 10



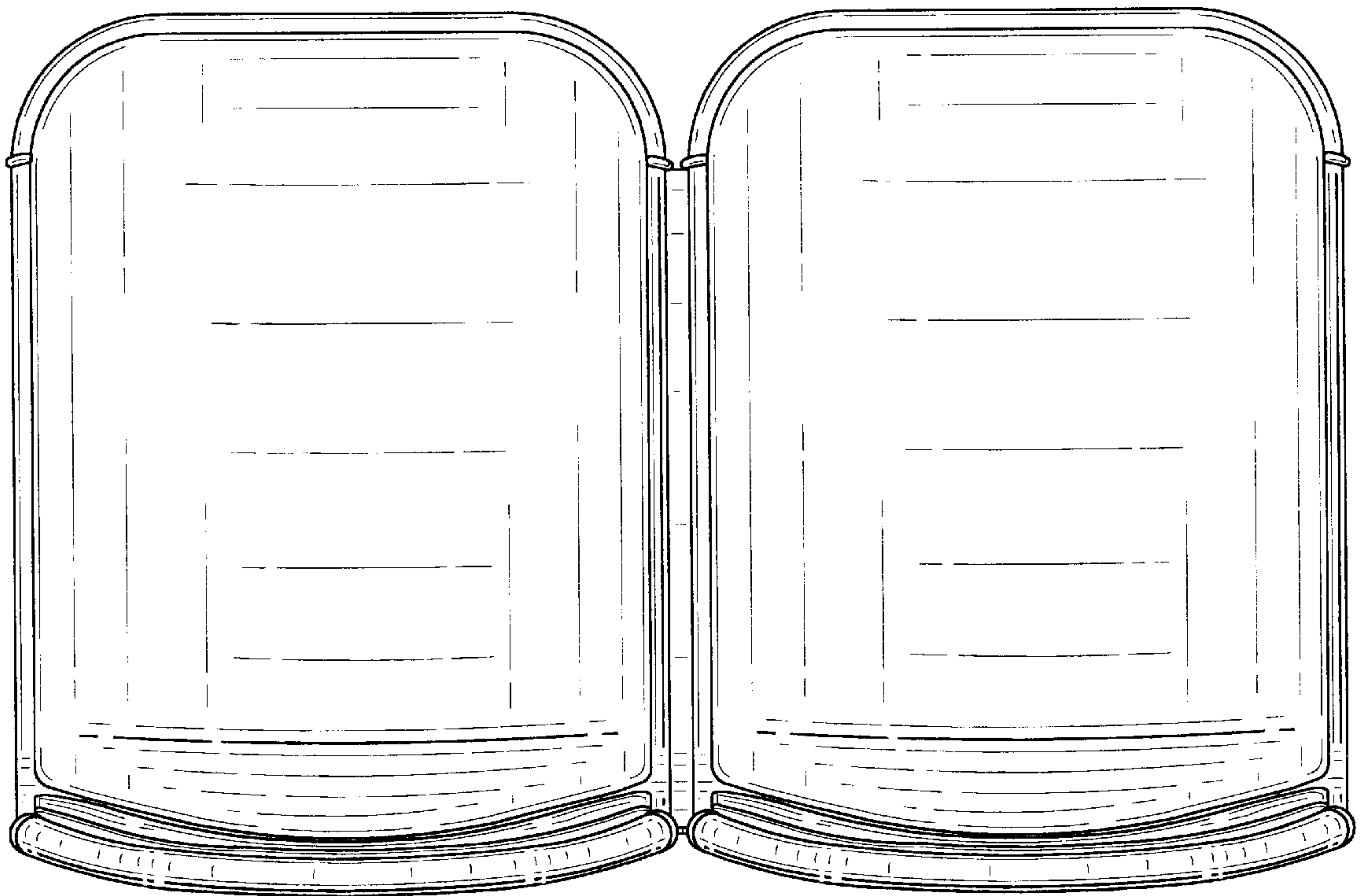

FIG. 8

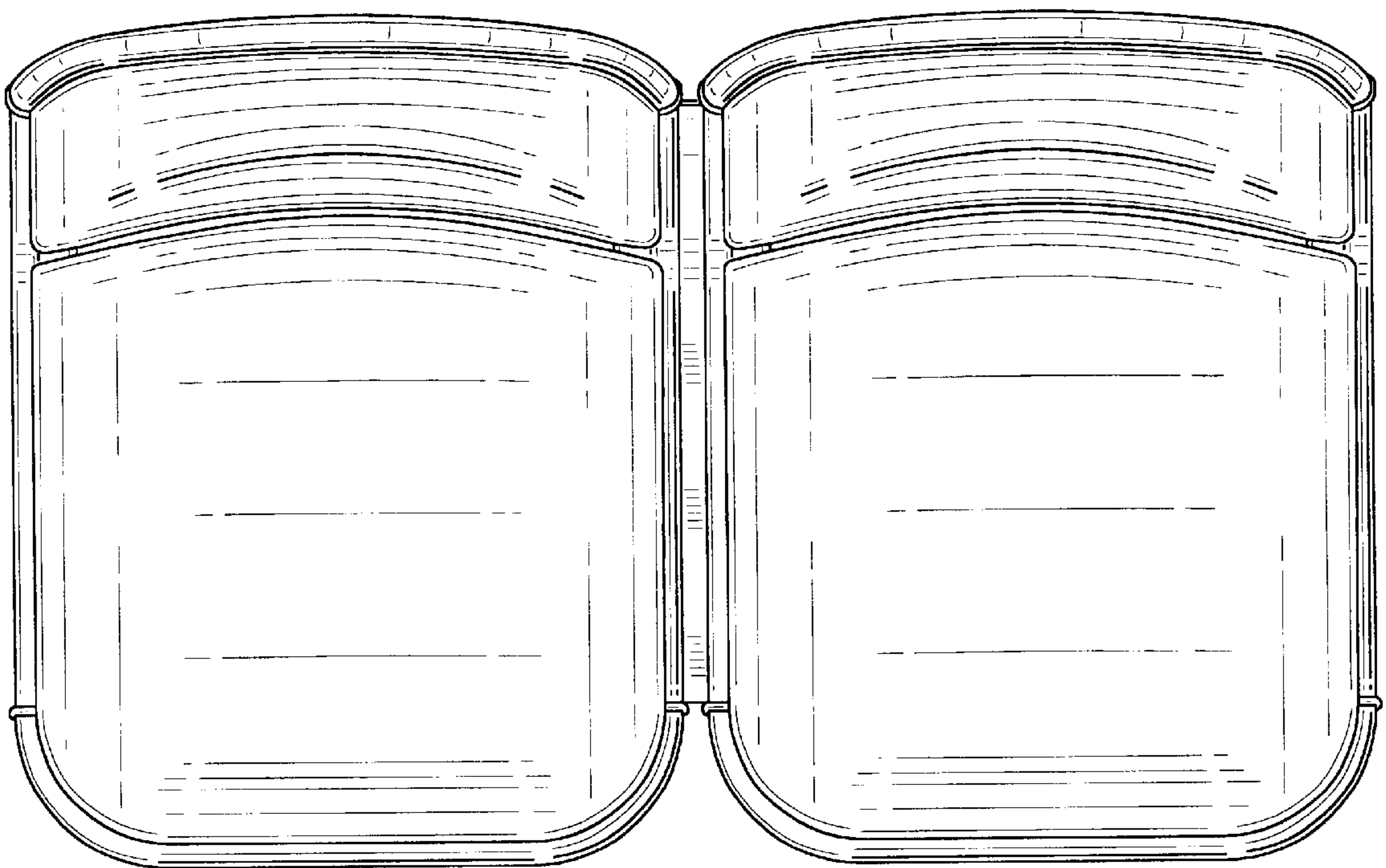

FIG. 11

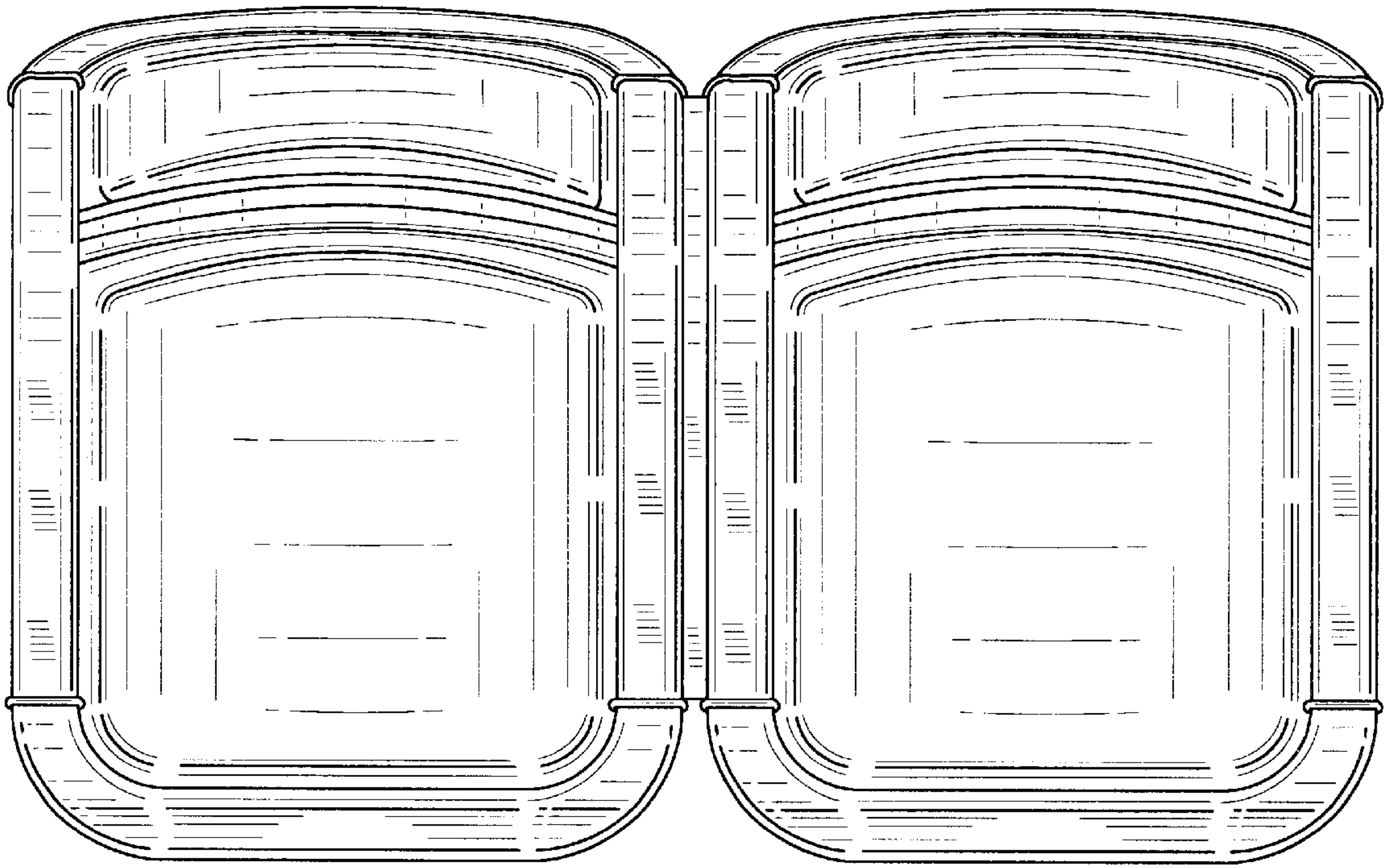

FIG. 12

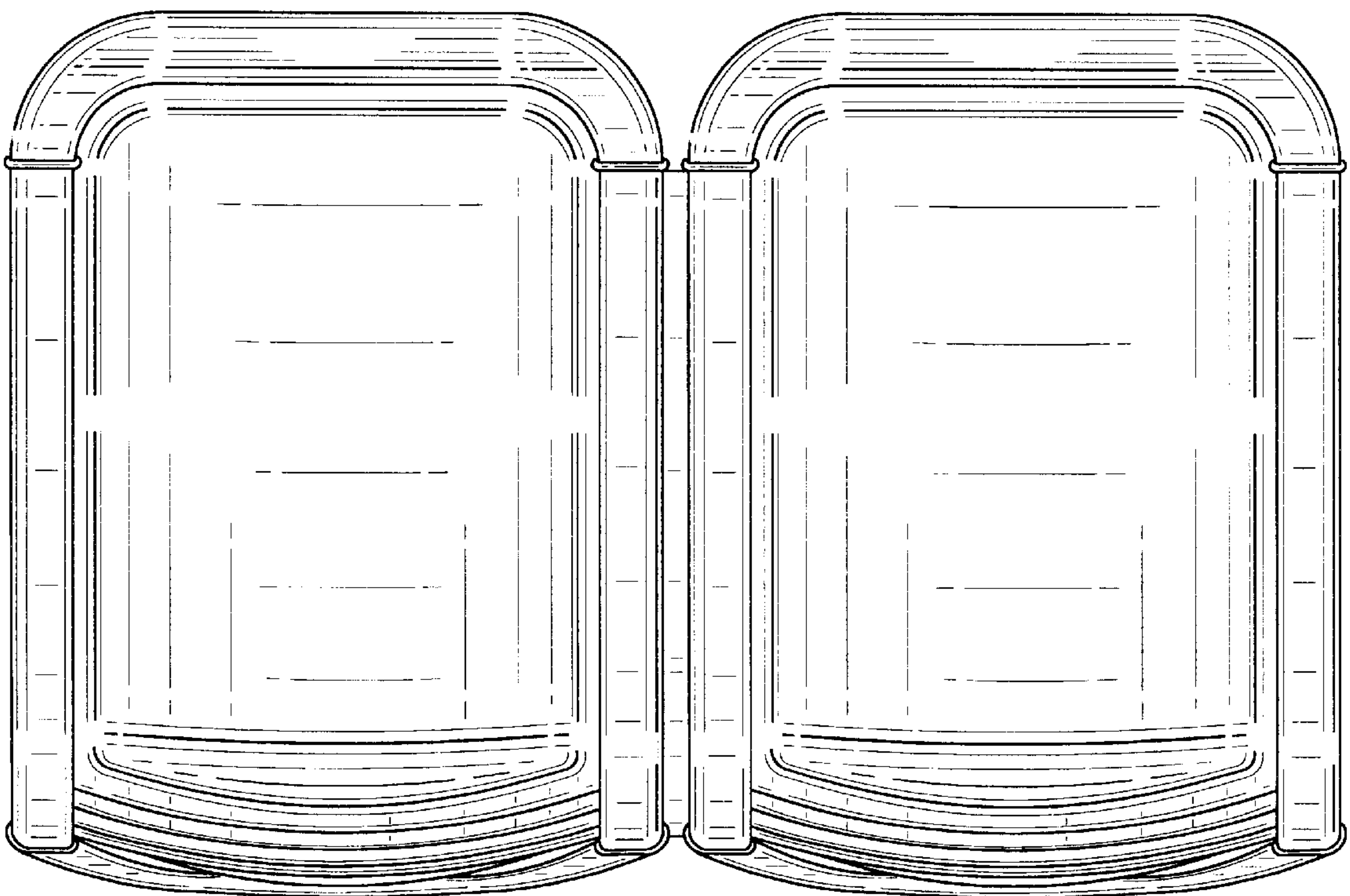

FIG. 9