



US00D485340S

(12) **United States Design Patent**
Wu

(10) **Patent No.:** **US D485,340 S**

(45) **Date of Patent:** **** Jan. 13, 2004**

(54) **COMBINED AUTOMOBILE AIR FRESHENER AND FAN ASSEMBLY**

(76) **Inventor:** **Henry Wu**, Fl. 3, No. 6, Alley 59, Lane 42, Ming Chuan Rd., Shin-Tien City, Taipei (TW), 231

(**) **Term:** **14 Years**

(21) **Appl. No.:** **29/162,453**

(22) **Filed:** **Jun. 14, 2002**

(30) **Foreign Application Priority Data**

May 2, 2002 (GB) 3003351

(51) **LOC (7) Cl.** **23-04**

(52) **U.S. Cl.** **D23/366**

(58) **Field of Search** D23/366-69; 239/34, 239/60, 211, 53-6; 422/120, 122-4

(56) **References Cited**

U.S. PATENT DOCUMENTS

- D398,047 S * 9/1998 Chen
- D398,976 S * 9/1998 Green
- 5,865,372 A * 2/1999 Ceresko

D419,659 S * 1/2000 Yang

D422,350 S * 4/2000 Wu

6,080,367 A * 6/2000 Lin

6,103,210 A * 8/2000 Hung

D465,019 S * 10/2002 Wu

* cited by examiner

Primary Examiner—M. H. Tung

(74) *Attorney, Agent, or Firm*—Ira S. Dorman

(57) **CLAIM**

The ornamental design for a combined automobile air freshener and fan assembly, as shown and described.

DESCRIPTION

FIG. 1 is a perspective view of a combined automobile air freshener and fan assembly embodying the present invention, on an enlarged scale;

FIG. 2 is a front view of the assembly;

FIG. 3 is a rear view of the assembly;

FIG. 4 is a left side view of the assembly;

FIG. 5 is a right side view of the assembly;

FIG. 6 is a top view of the assembly; and,

FIG. 7 is a bottom view of the assembly.

1 Claim, 4 Drawing Sheets

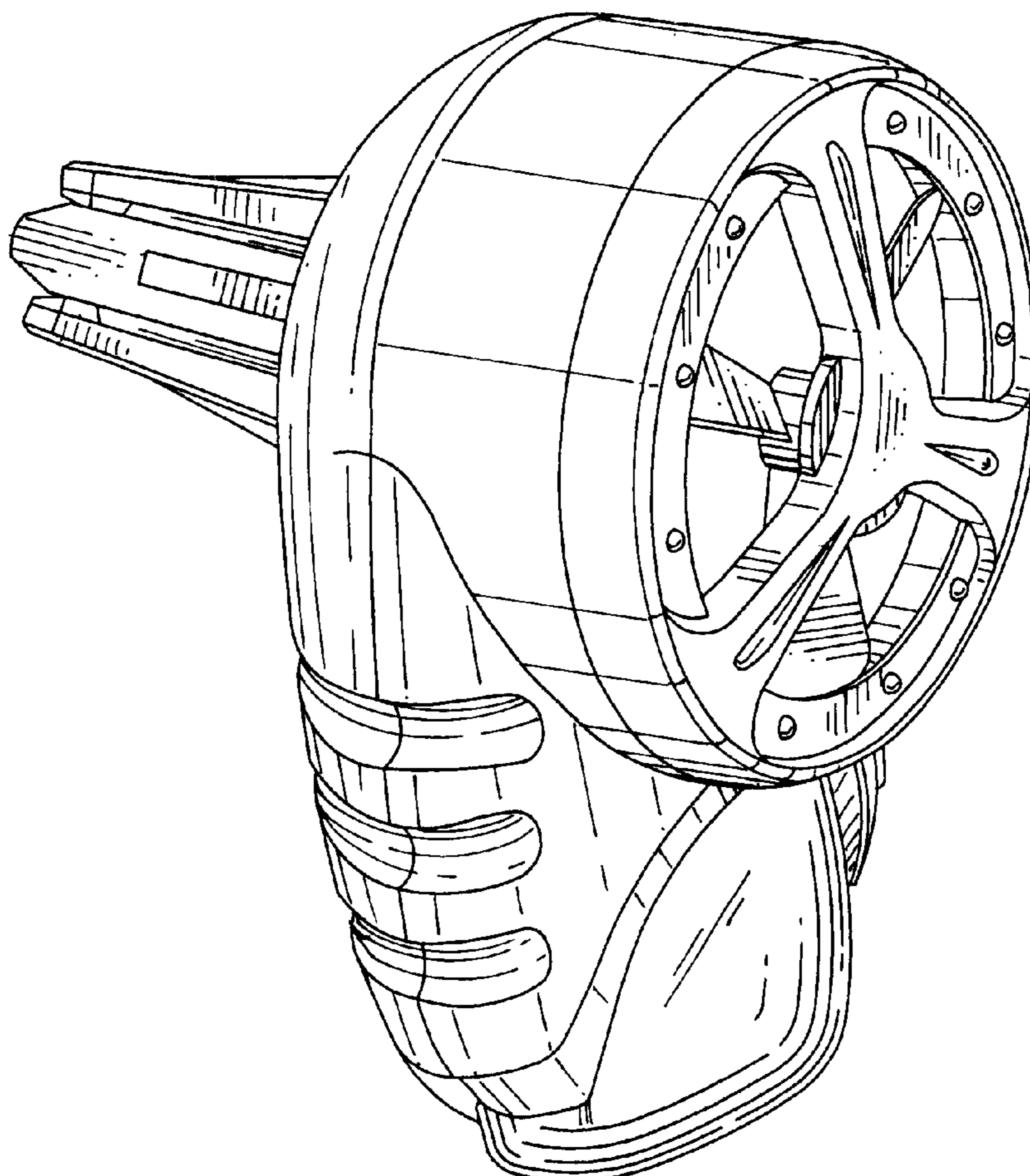

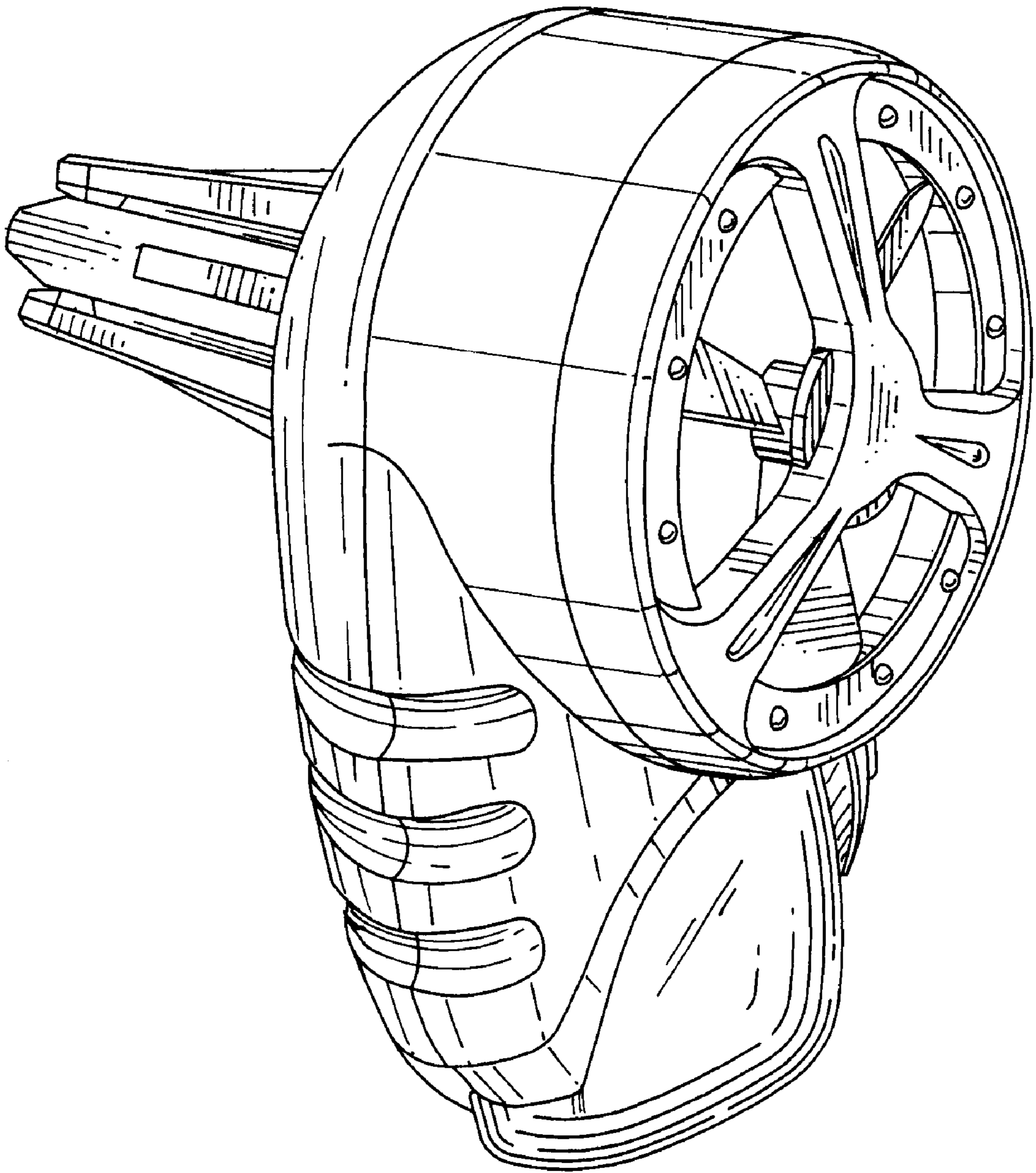

Fig.1

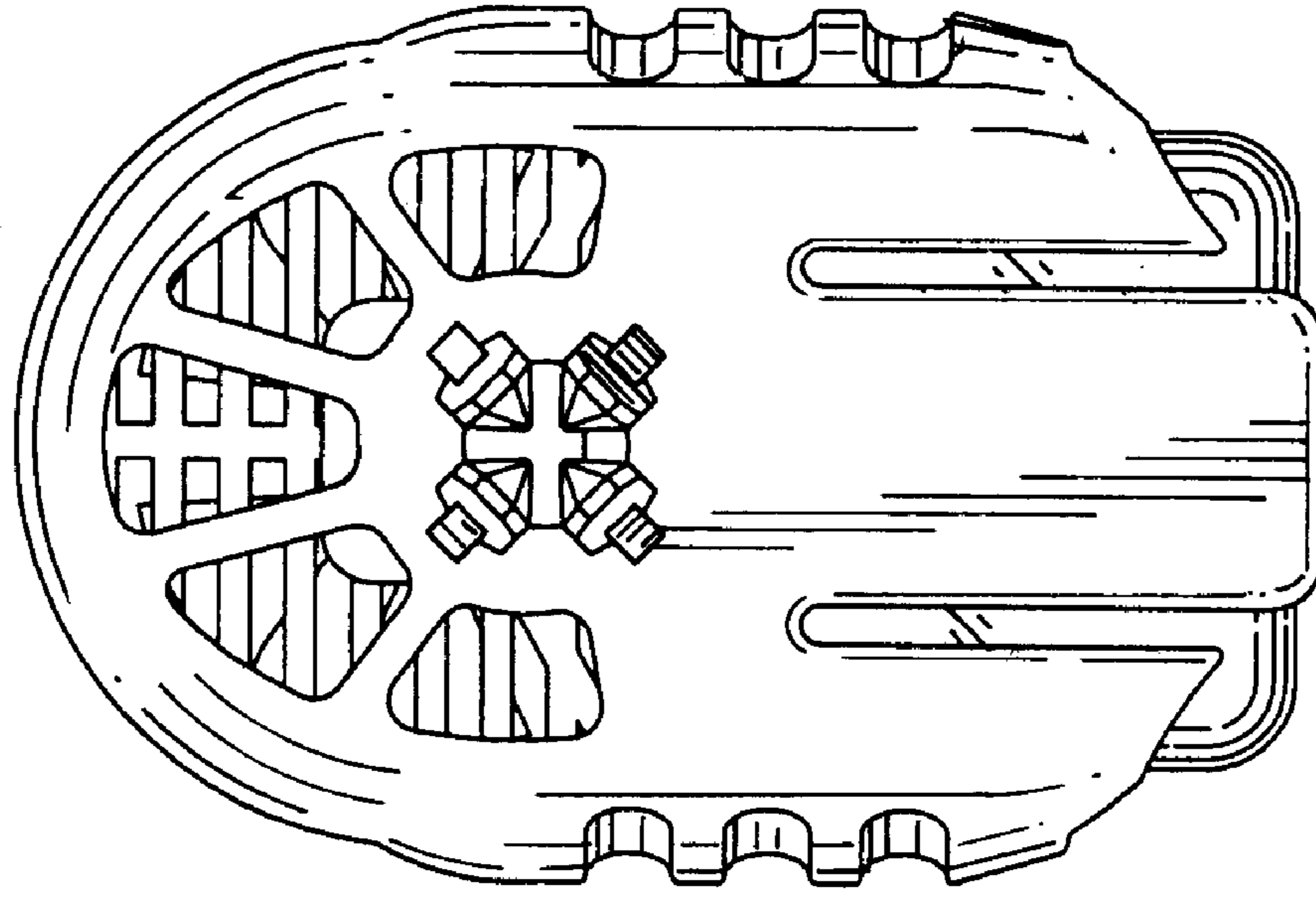

Fig. 3

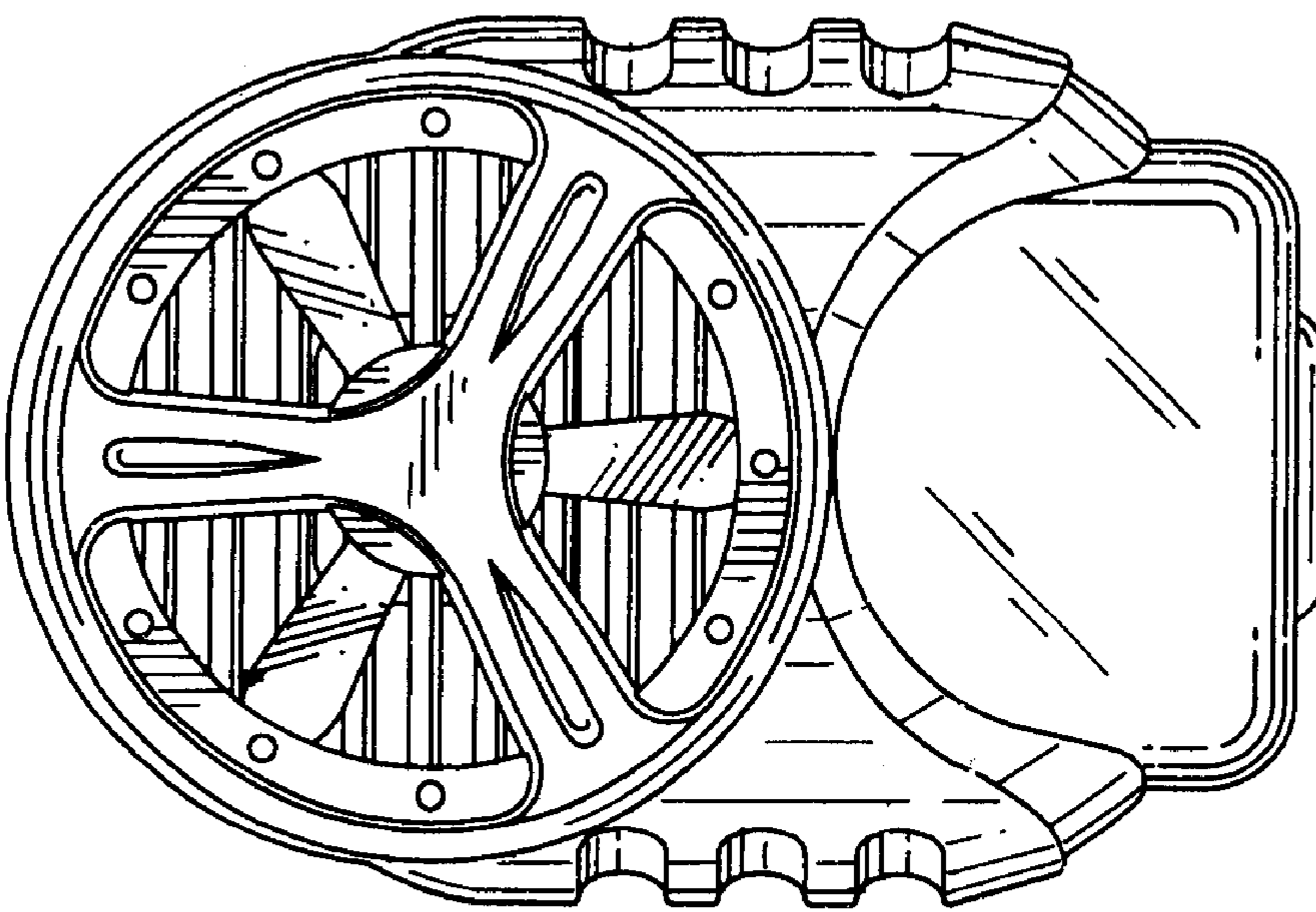

Fig. 2

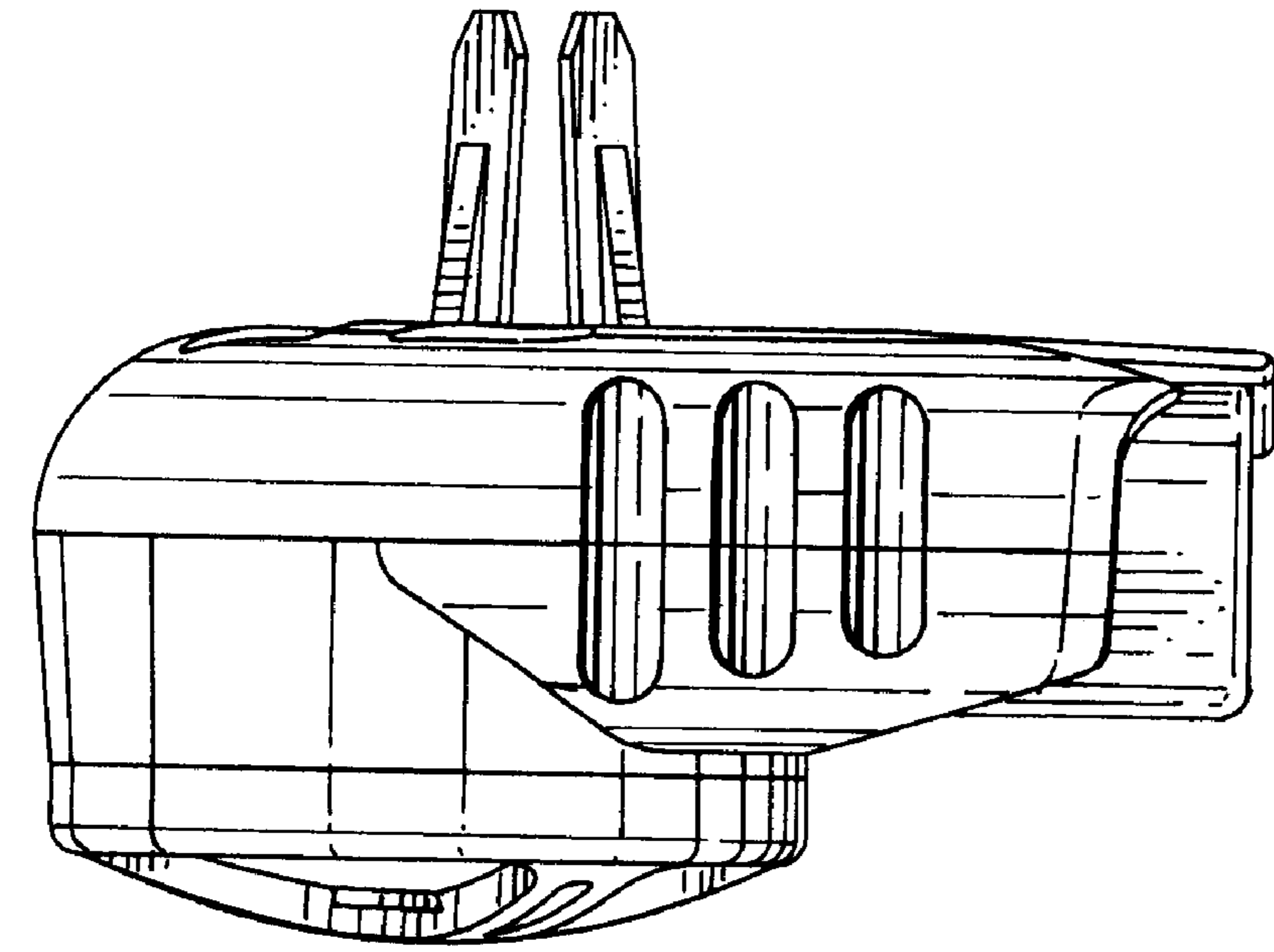

Fig.5

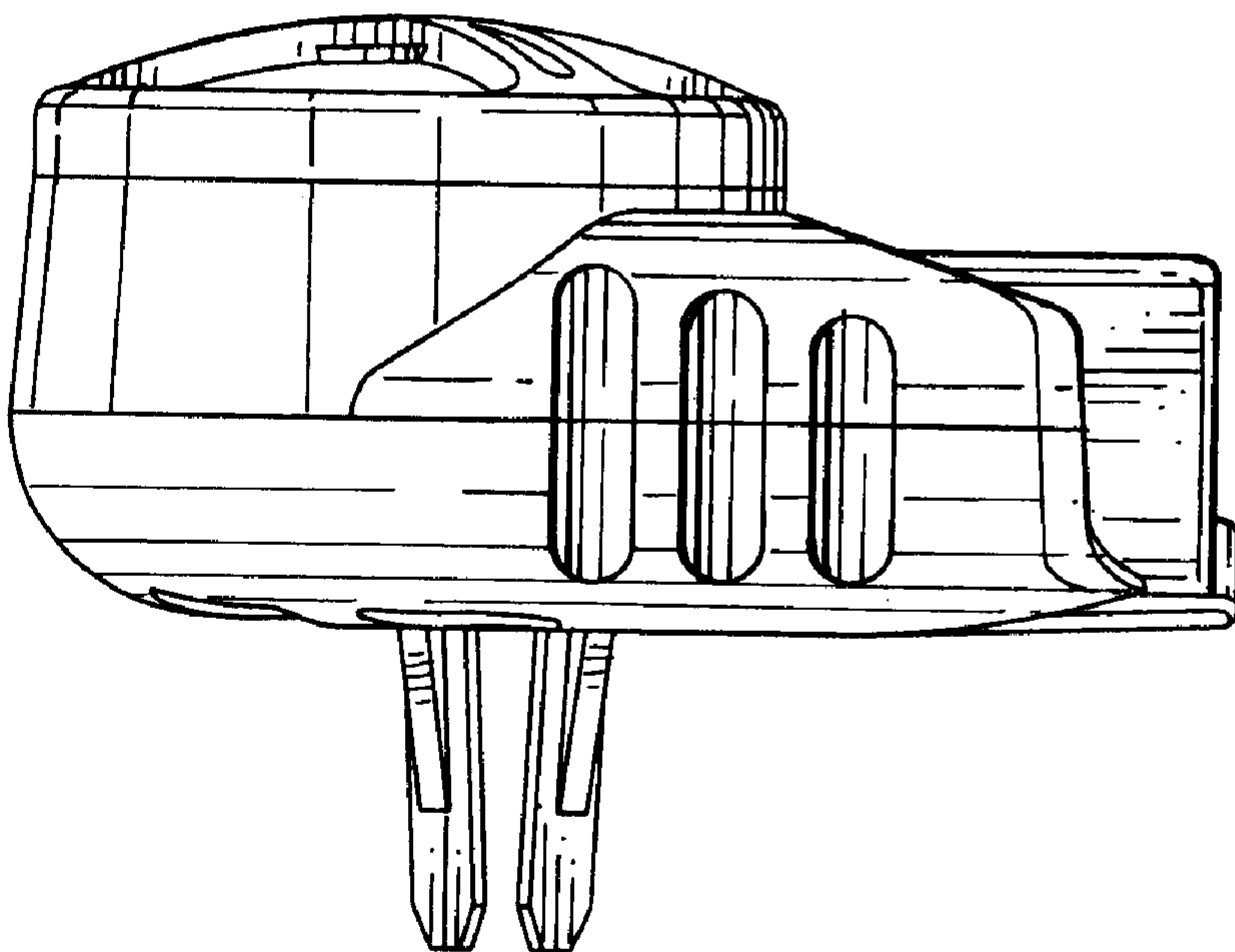

Fig.4

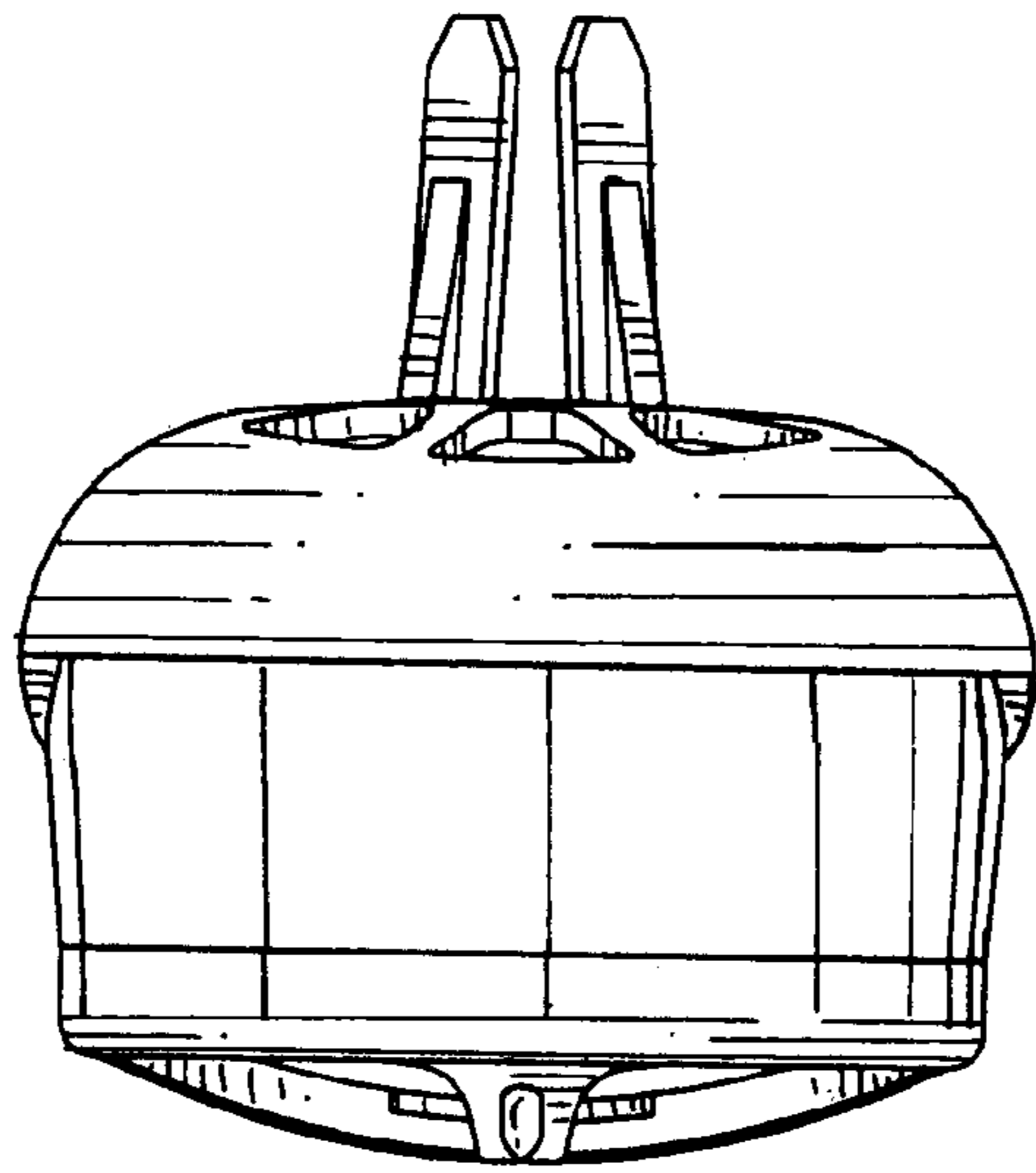

Fig.6

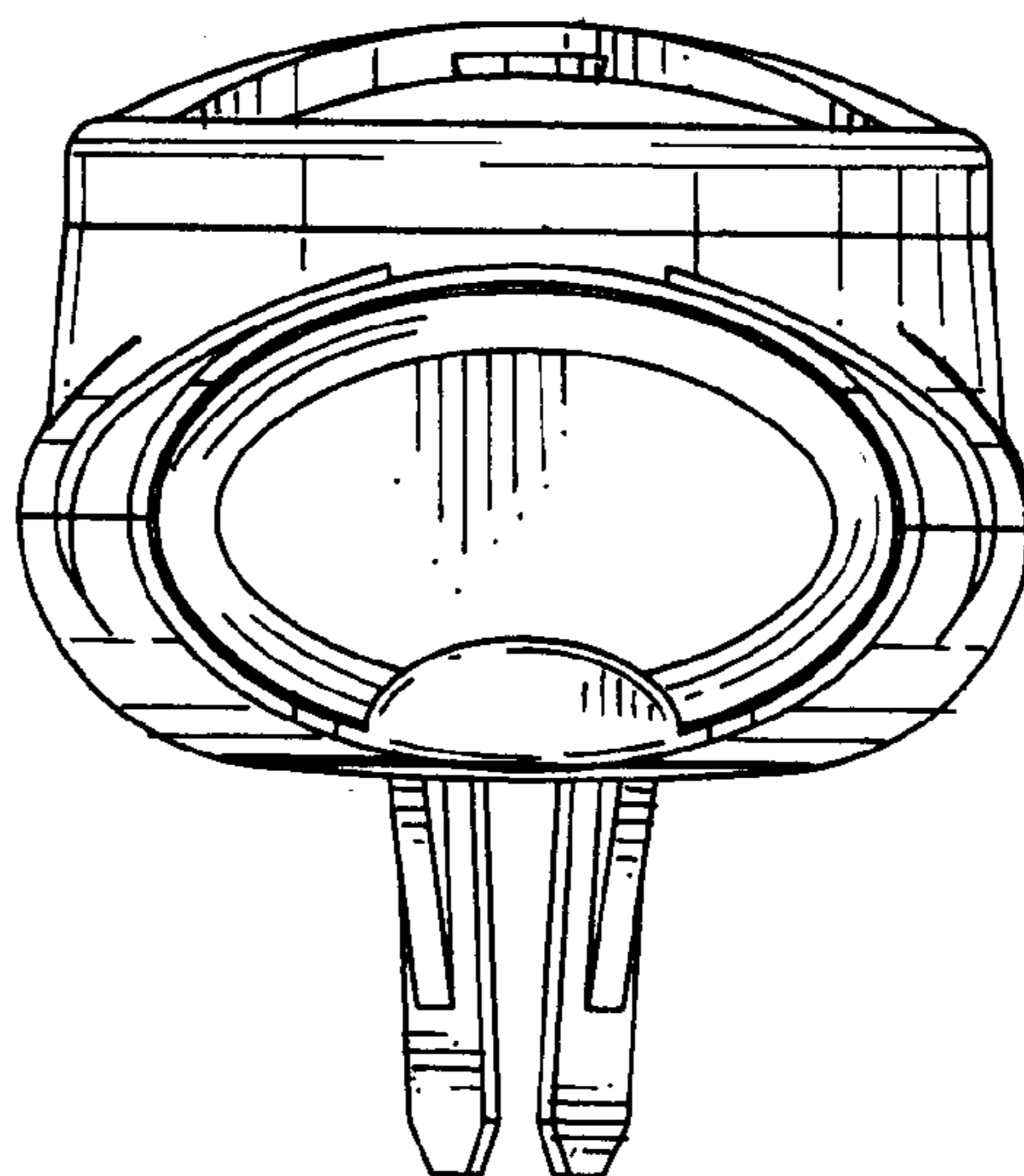

Fig.7