



US00D485225S

(12) **United States Design Patent**
Montgomery

(10) **Patent No.:** **US D485,225 S**

(45) **Date of Patent:** **** Jan. 13, 2004**

(54) **BASE FOR A SPORTFISHING BOAT SEATING CONSOLE**

5,209,178 A 5/1993 Rowe
5,269,157 A 12/1993 Ciminelli et al.
5,692,335 A 12/1997 Magnuson
5,799,605 A 9/1998 Huse
5,913,571 A 6/1999 Dystra et al.

(75) **Inventor:** **Stewart M. Montgomery**, Wilmington, NC (US)

(73) **Assignee:** **Command Center Seating, Inc.**, Wilmington, NC (US)

(**) **Term:** **14 Years**

(21) **Appl. No.:** **29/162,690**

(22) **Filed:** **Jun. 19, 2002**

Related U.S. Application Data

(63) Continuation of application No. 29/156,514, filed on Mar. 1, 2002, now abandoned.

(51) **LOC (7) Cl.** **12-06**

(52) **U.S. Cl.** **D12/317**

(58) **Field of Search** D12/318, 317;
114/188, 255, 364

(56) **References Cited**

U.S. PATENT DOCUMENTS

395,870 A	1/1889	Blydenburgh
2,264,744 A	12/1941	Dunnam
2,472,185 A	6/1949	Apel
2,681,809 A	6/1954	Hamill
2,812,227 A	11/1957	Hill
2,971,568 A	2/1961	Rorie
3,376,587 A	4/1968	Staron
3,379,471 A	4/1968	Dalziel
3,473,176 A	10/1969	Taylor
3,884,522 A	5/1975	Arima et al.
4,567,845 A	2/1986	Smith
4,637,081 A	1/1987	Clark
4,693,204 A	9/1987	Klein
4,738,217 A	4/1988	Smith
4,854,261 A	8/1989	Goldsmith
4,893,578 A	1/1990	Doerfer et al.
4,919,068 A	4/1990	Lathers
4,989,535 A	2/1991	Lacasse et al.
5,136,963 A	8/1992	Zuzik

OTHER PUBLICATIONS

Material describing for Leaning Post/Baitwell Combo (McKee Custom Boats—Bolivia, North Carolina)—on sale since 1997.

Copy of advertisement for “High Performance Bolster Setting” (Offshore Performance Products).

Copy of advertisement for “Travis Boating Center”, TIDE magazine, Jan./Feb. 2001. Table of Contents page and pp. 2–3.

Copy of advertisement for “Red Wing Boat Company, Inc.” (Houston, Texas), TIDE magazine, Jan./Feb. 2001, p. 22.

Copy of advertisement for “Pursuit” (Ft. Pierce, Florida), Florida Sportsman magazine, Apr. 2000, p. 19.

Copy of advertisement for “FS Marlago® Sport Edition” Jefferson Yachts, (Jefferson, Indiana), Florida Sportsman magazine, Apr. 2000, p. 48.

Copy of advertisement for “Nissan Marine”, Nissan Marine and Power Products, Florida Sportsman magazine, Apr. 2000, p. 71.

(List continued on next page.)

Primary Examiner—Lisa Lichtenstein

(74) *Attorney, Agent, or Firm*—Daniels Daniels & Verdonik, P.A.; Kevin E. Flynn

(57) **CLAIM**

The ornamental design for a base for a sportfishing boat seating console, as shown and described.

DESCRIPTION

FIG. 1 is a perspective view of the boat seating console base as viewed from the right front.

FIG. 2 is a side view of the boat seating console base.

FIG. 3 is a rear view of the boat seating console base; and, FIG. 4 is a top view of the boat seating console base.

The bottom of the sportfishing boat seating console base is plain and unornamented. One side is the mirror image of the other side.

1 Claim, 2 Drawing Sheets

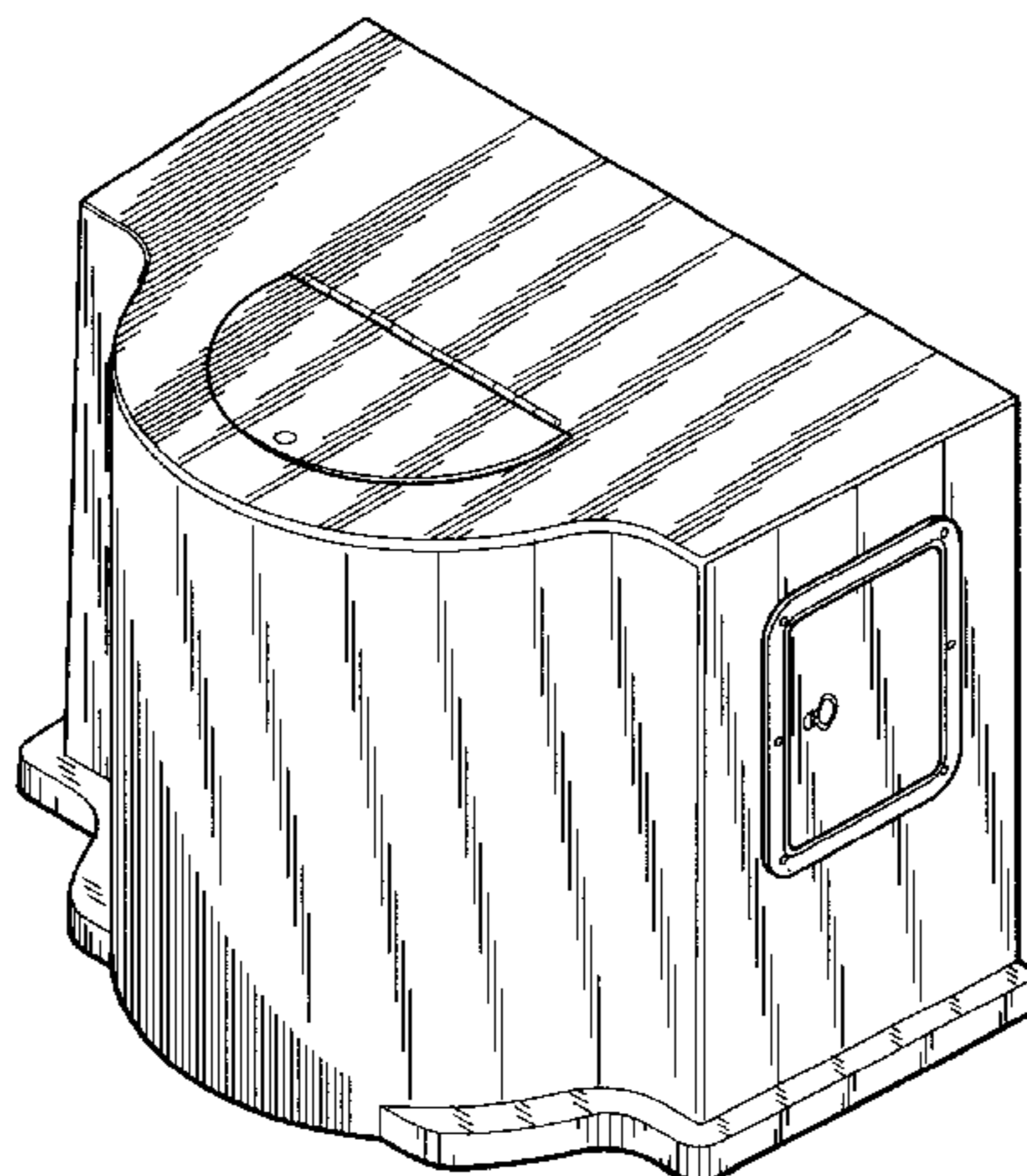

OTHER PUBLICATIONS

Copy of advertisement for "World Class Catamarans", World Class Catamarans, (Greenville, North Carolina), Florida Sportsman magazine, Apr. 2000, p. 91.

Copy of advertisement for "Pro-Trim", Pro-Trim Fishing and Construction Products, Florida Sportsman magazine, Apr. 2000, p. 95.

Copy of advertisement for "Triton Boats", Triton Boats, (Ashland City, Tennessee), Florida Sportsman magazine, Feb., 2001, p. 105.

Copy of advertisement for "Honda Marine", American Honda Motor Company, Florida Sportsman magazine, Feb., 2001, p. 135.

Copy of advertisement for "Key Largo 236", Mercury Outboards, (Douglas, Georgia), Florida Sportsman magazine, Feb., 2001, p. 162.

Web pages from www.spacemkr.com for "Space Makers" by Morsch Marine Construction Supply, printed Jul. 26, 2001: • Leaning Posts (3 pages), <http://www.spacemkr.com/LPC-C.htm>, • Center Consoles (2 pages), <http://www.spacemkr.com/consoles.htm>.

Web pages and copy of advertisement from www.donzimarine.com, "Donzi" of Tallevast, Florida, printed Jul. 26, 2001: • ZF Series (2 pages), http://www.donzimarine.com/series/zf/zf_series.html, • 32 ZF Series (2 pages), <http://www.donzimarine.com/series/zf/32zf.html>, • 35 ZFC Daytona Series (2 pages), <http://www.donzimarine.com/series/zf/zfdaytonas.html>, • ZF Pro Series (3 pages), <http://www.donzimarine.com/series/zf/zfpro.html>.

Web pages from www.seacraft-boats.com, "Seacraft", printed Jul. 26, 2001: • 2001 SeaCraft 25 (2 pages), <http://www.seacraft-boats.com/SC%2025.html>, • 2001 Seacraft 32 (2 pages), <http://www.seacraft-boats.com/SC%2025.html>.

Web pages and copy of advertisement from www.dusky.com, "Dusty Factory Direct", Dania Beach, Florida, printed Jul. 26, 2001: • Dusky (1 page), <http://www.dusky.com/256facab.JPG.html>, • Options List (4 pages), <http://www.dusky.com/options.html>.

Copy of Command Center Seating brochure featuring "The Grand" model with blow-up of model, "The Grand".

Copy of Command Center Seating brochure featuring "The Low Boy" model with blow-up of model, "The Low Boy".

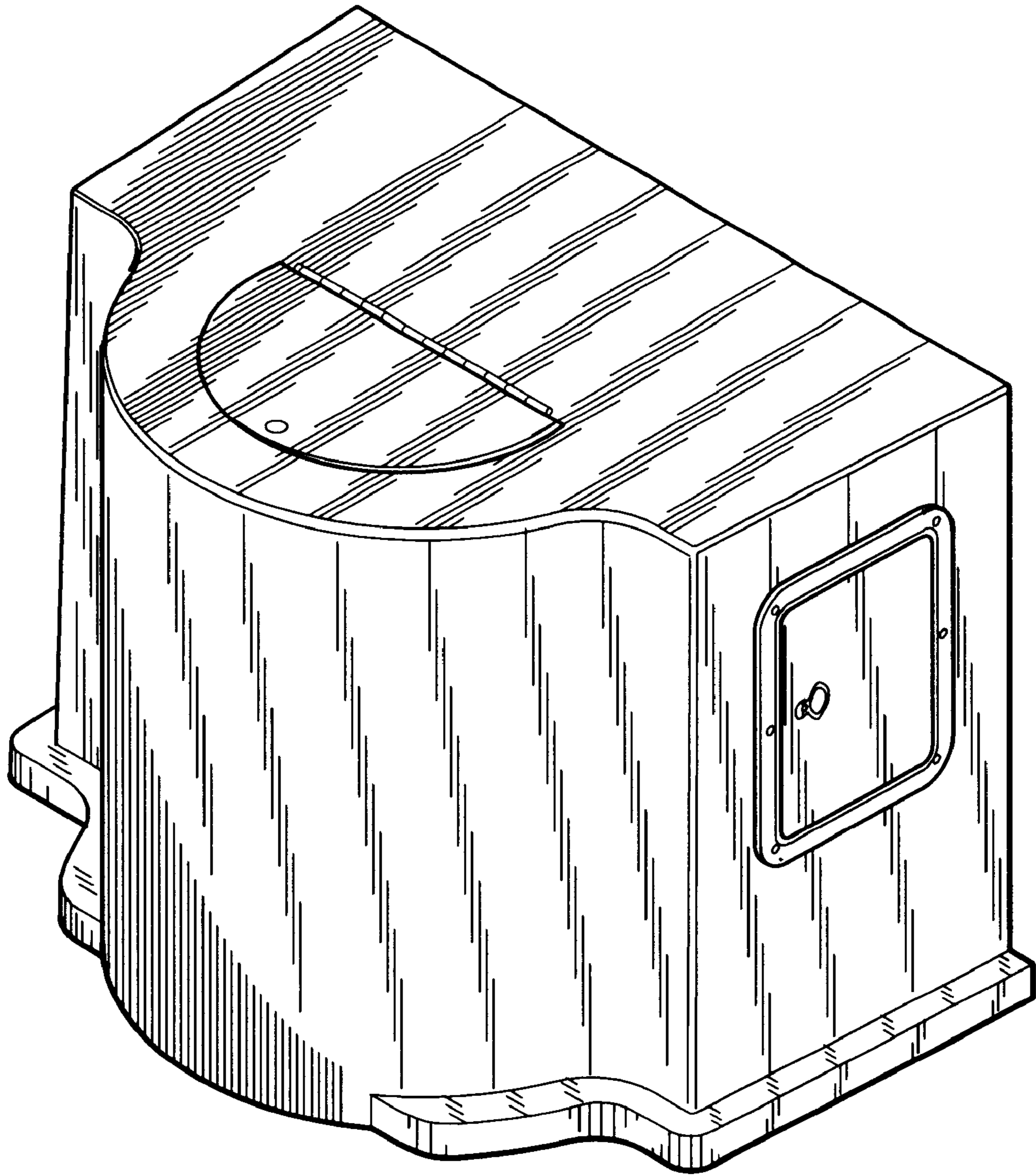

Fig. 1

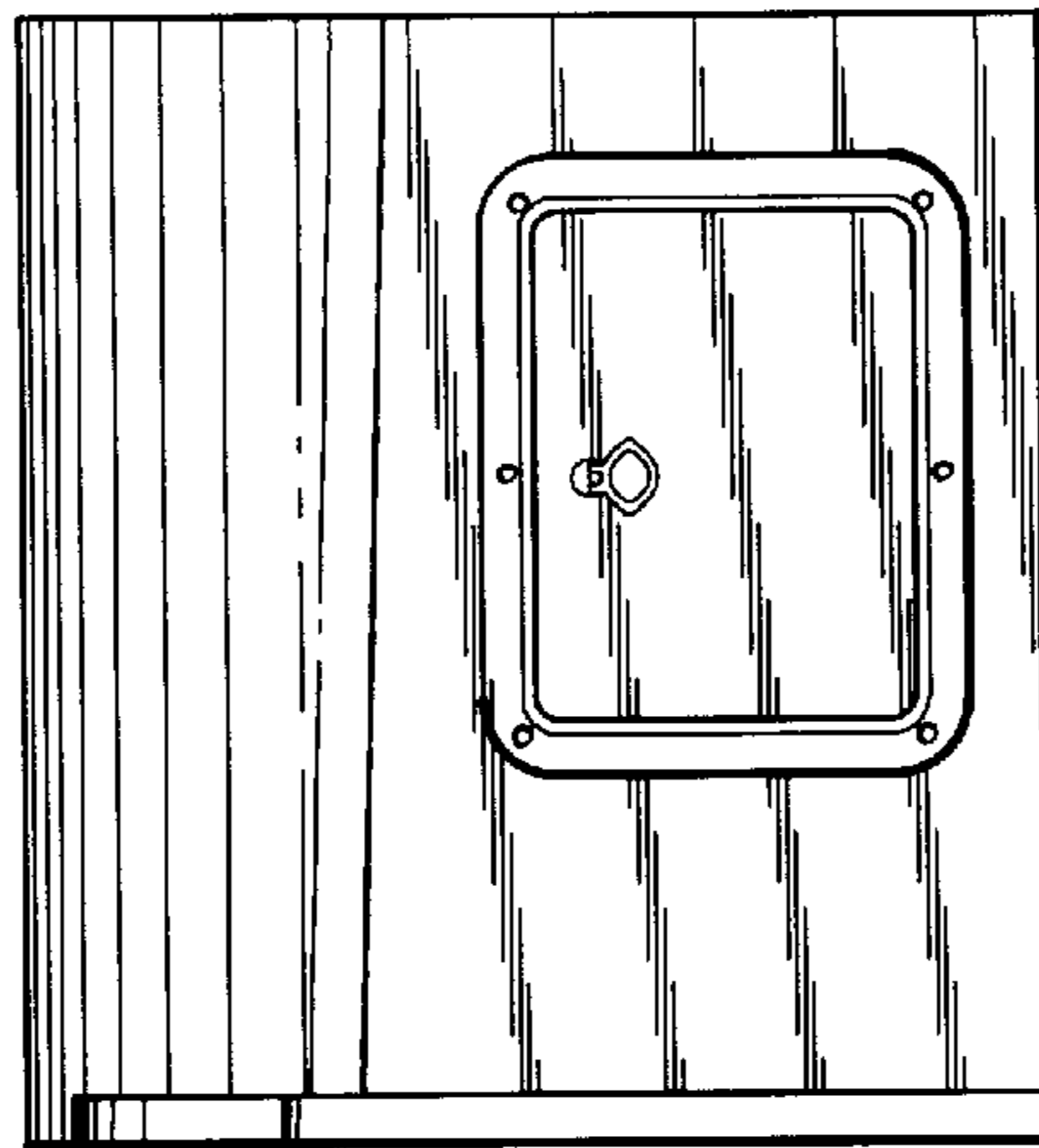

Fig. 2

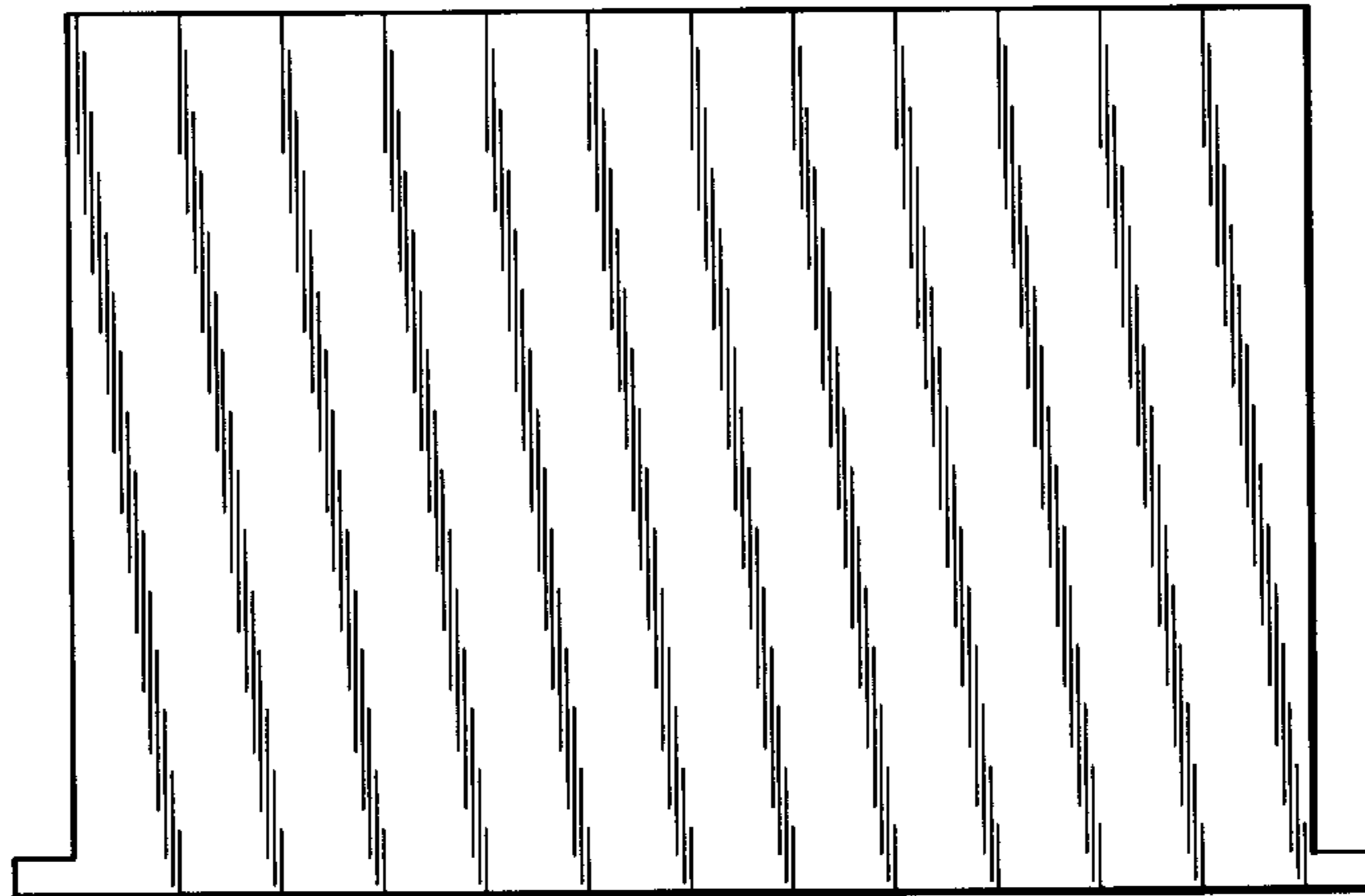

Fig. 3

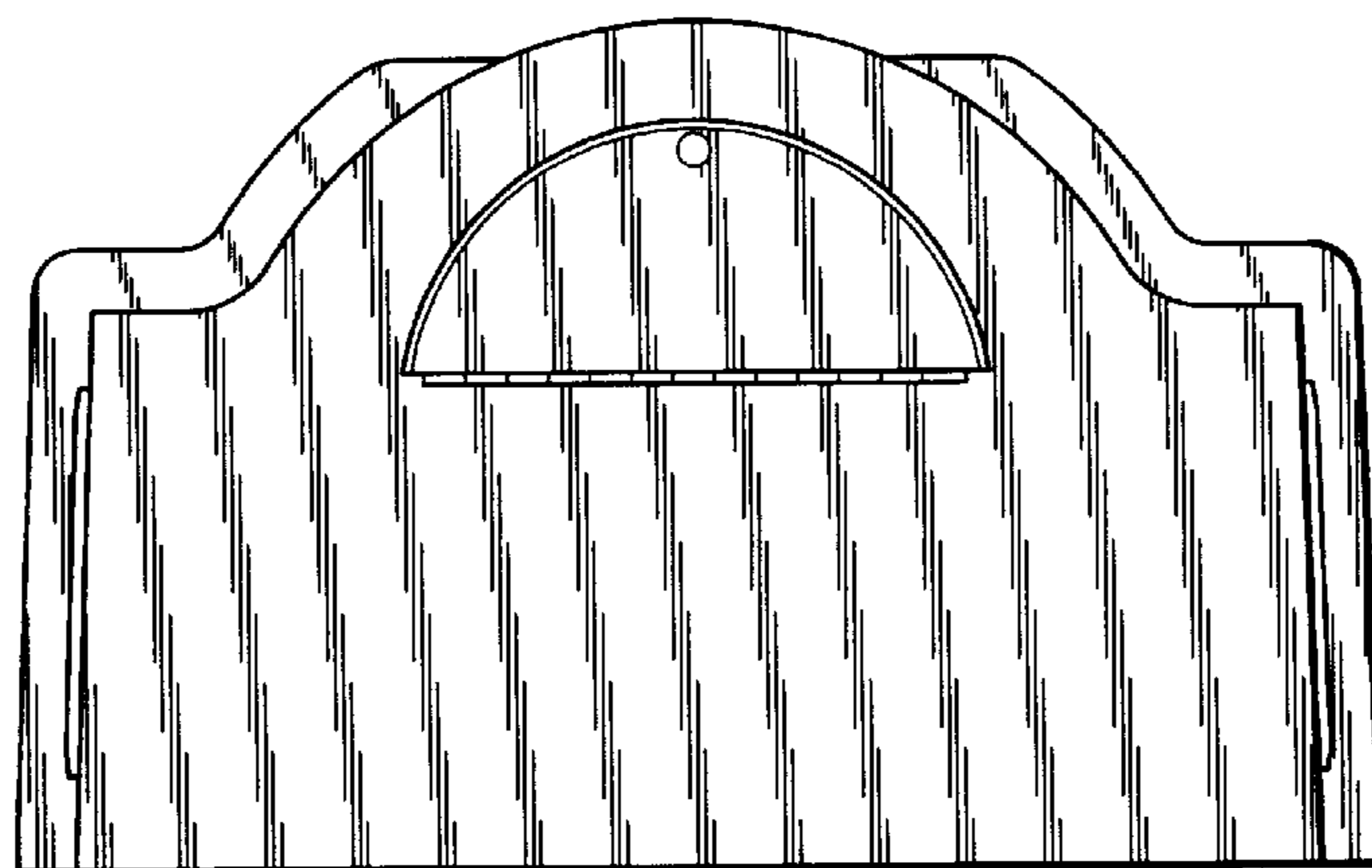

Fig. 4