



US00D485215S

(12) **United States Design Patent**
de Oliveira

(10) **Patent No.:** **US D485,215 S**
(45) **Date of Patent:** **** Jan. 13, 2004**

(54) **TRICYCLE WITH AN ADDITIONAL REAR SEAT**

(75) Inventor: **Joaquim Matias de Oliveira,**
Guarulhos (BR)

(73) Assignee: **Magic Toys do Brasil Ind. e Com. Ltda.,**
Guarulhos (BR)

(**) Term: **14 Years**

(21) Appl. No.: **29/152,868**

(22) Filed: **Jan. 4, 2002**

(30) **Foreign Application Priority Data**

Jul. 6, 2001 (BR) DI6101495

(51) **LOC (7) Cl.** **12-11**

(52) **U.S. Cl.** **D12/112**

(58) **Field of Search** D12/15, 108, 112,
D12/113; D21/431-435; 298/1 T; D6/354;
296/63, 65.01, 66, 177; 280/259, 267, 282;
414/317; 297/195.12, 195.13, 244, 245

(56) **References Cited**

U.S. PATENT DOCUMENTS

D217,545 S	*	5/1970	Plessinger	D12/110
D290,450 S	*	6/1987	Rudell et al.	D12/108
D337,973 S	*	8/1993	Mariol	D12/112
D338,244 S	*	8/1993	Gault	D21/433

* cited by examiner

Primary Examiner—Alan P. Douglas

Assistant Examiner—Linda Brooks

(74) *Attorney, Agent, or Firm*—Birch, Stewart, Kolasch & Birch, LLP

(57) **CLAIM**

The ornamental design for a tricycle with an additional rear seat, substantially as shown and described.

DESCRIPTION

FIG. 1 is a partial perspective view of the tricycle of the present invention;
 FIG. 2 is a left side view of the tricycle of the present invention;
 FIG. 3 is a full perspective view of the tricycle of the present invention from a left rear perspective;
 FIG. 4 is a rear view of the tricycle of the present invention;
 FIG. 5 is a full perspective view of the tricycle of the present invention from a right rear perspective;
 FIG. 6 is a right side view of the tricycle of the present invention;
 FIG. 7 is a full perspective view of the tricycle of the present invention from a right, front perspective;
 FIG. 8 is a front view of the tricycle of the present invention from an elevated, front elevation;
 FIG. 9 is a full perspective view of the tricycle of the present invention from a left, front perspective;
 FIG. 10 is a right side view of the tricycle of the present invention containing a tiltable rear bucket seat;
 FIG. 11 is a perspective view of the tricycle of the present invention taken from a right front elevation;
 FIG. 12 is a perspective view of the tricycle of the present invention taken from a left rear elevation;
 FIGS. 13 and 14 show rear elevational views of the tricycle of the present invention showing the tiltable rear bucket seat in different positions; and,
 FIGS. 15 and 16 show respective side elevational views of FIGS. 13 and 14, of the tricycle of the present invention.

1 Claim, 3 Drawing Sheets

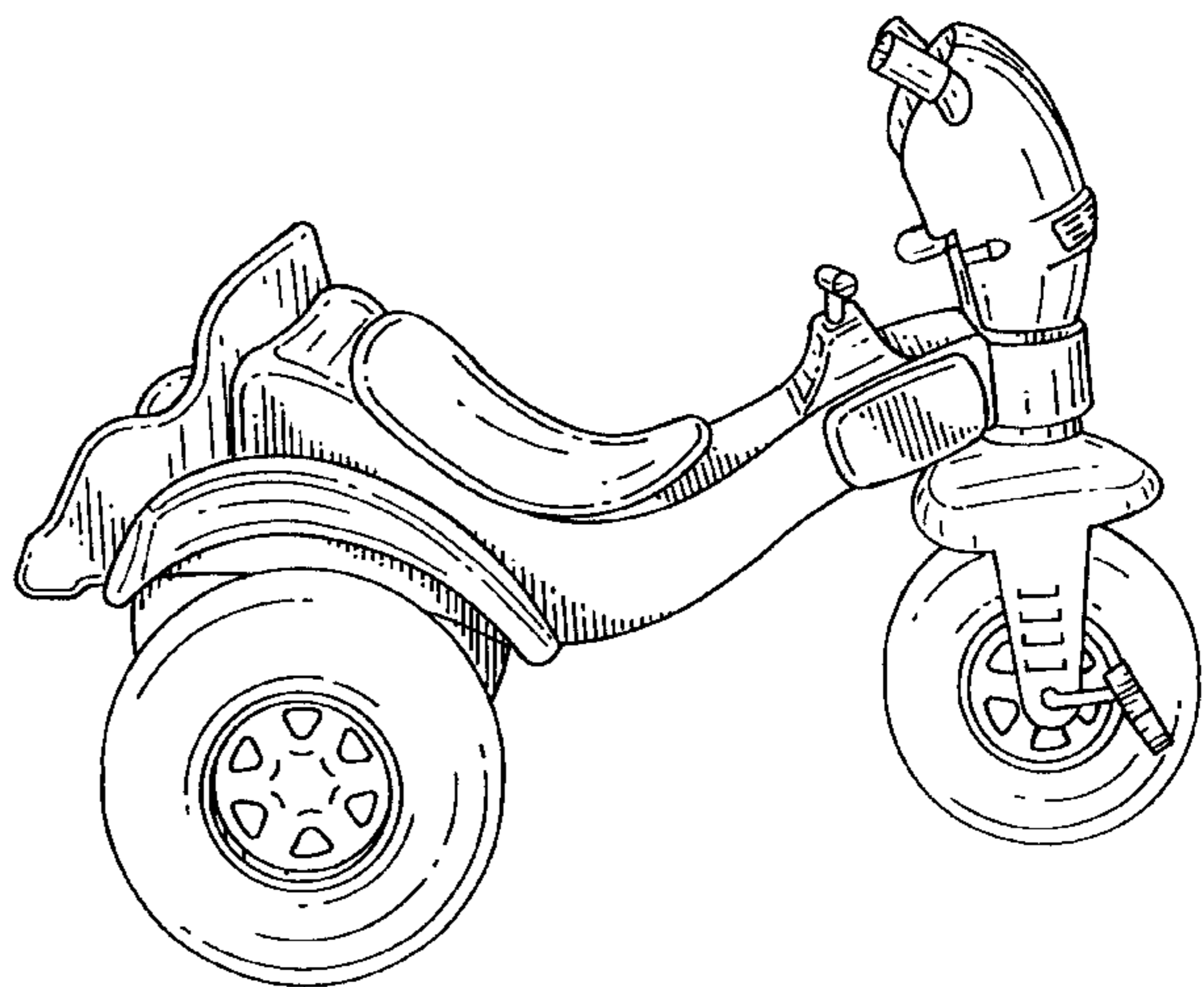
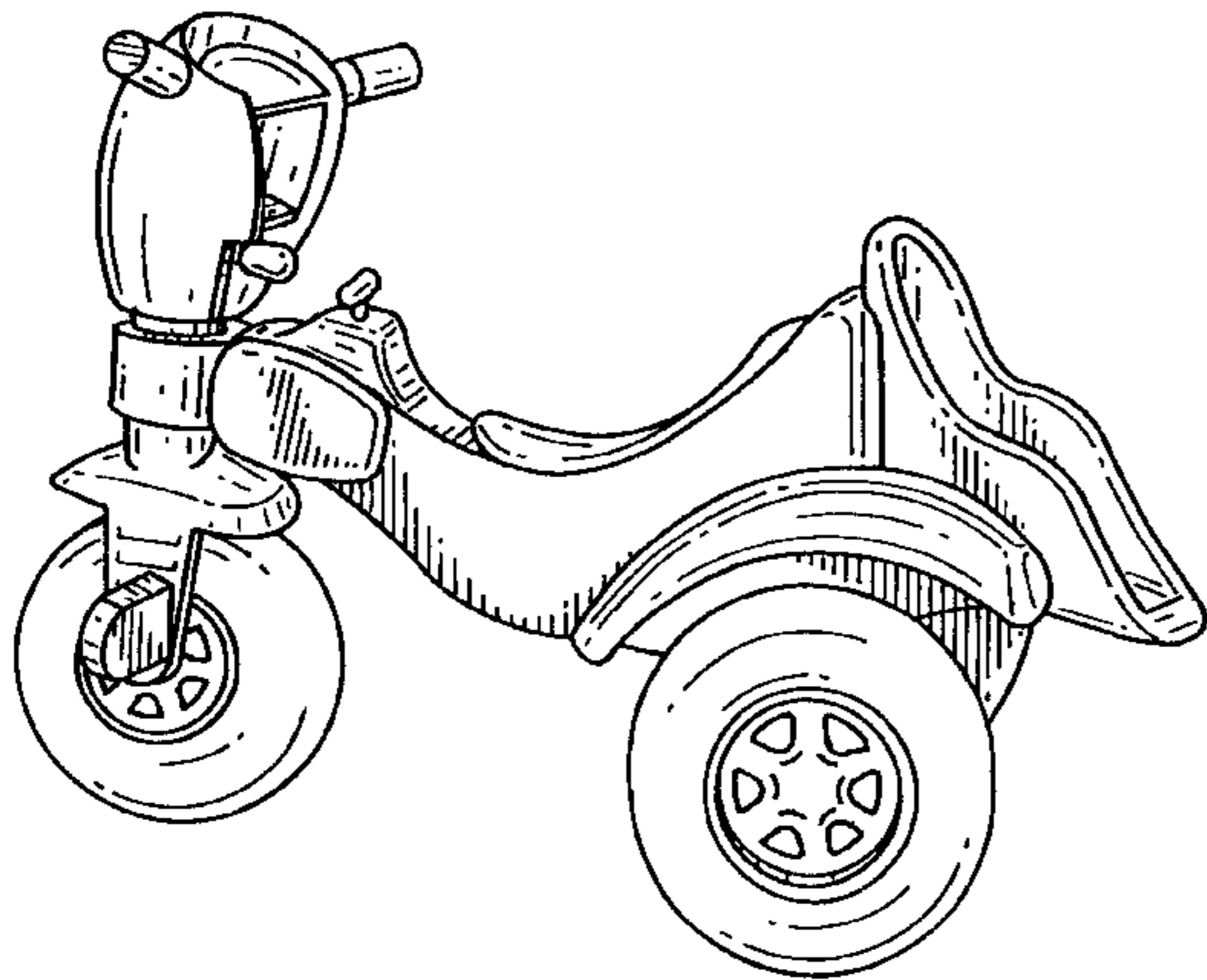

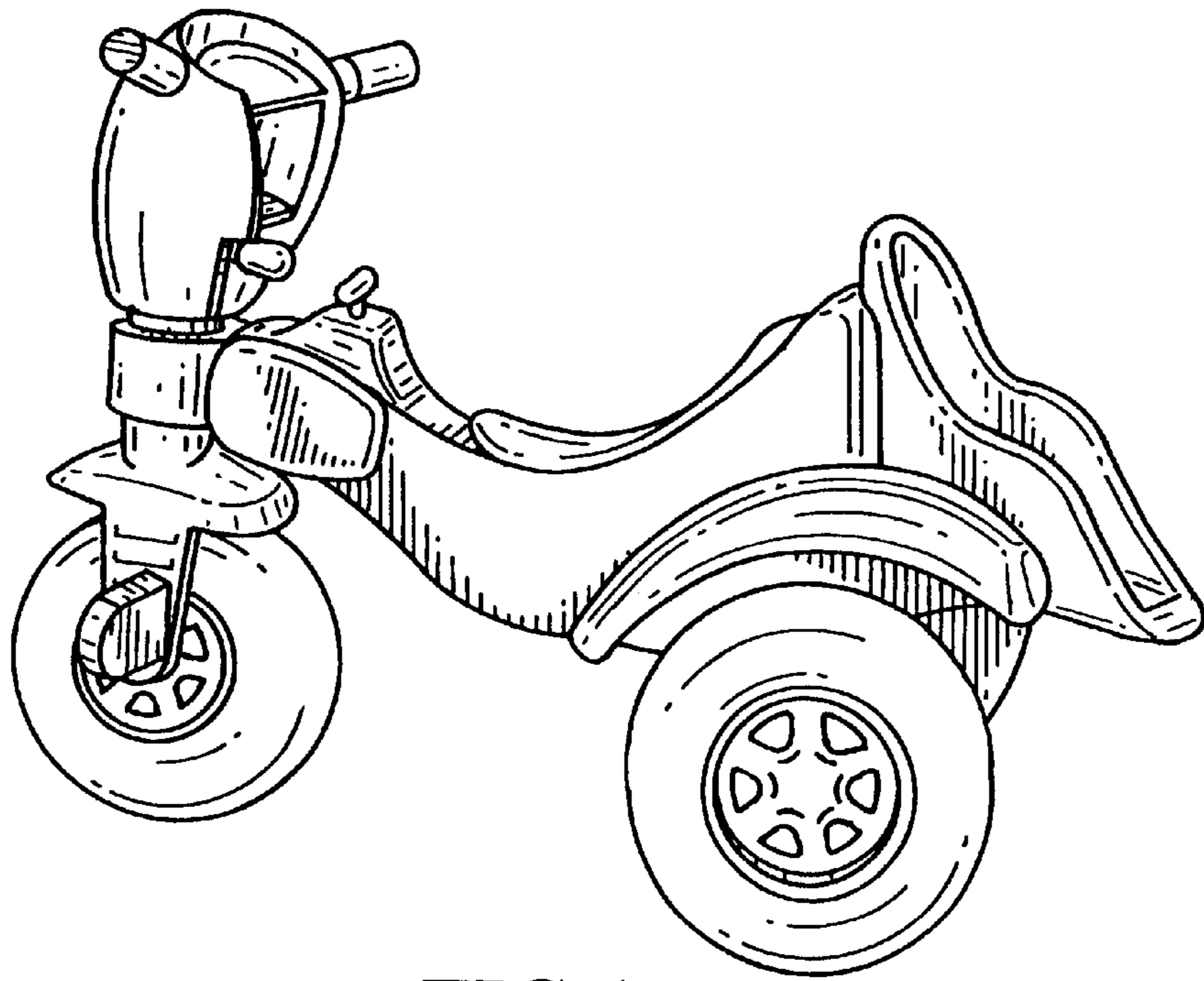

FIG. 1

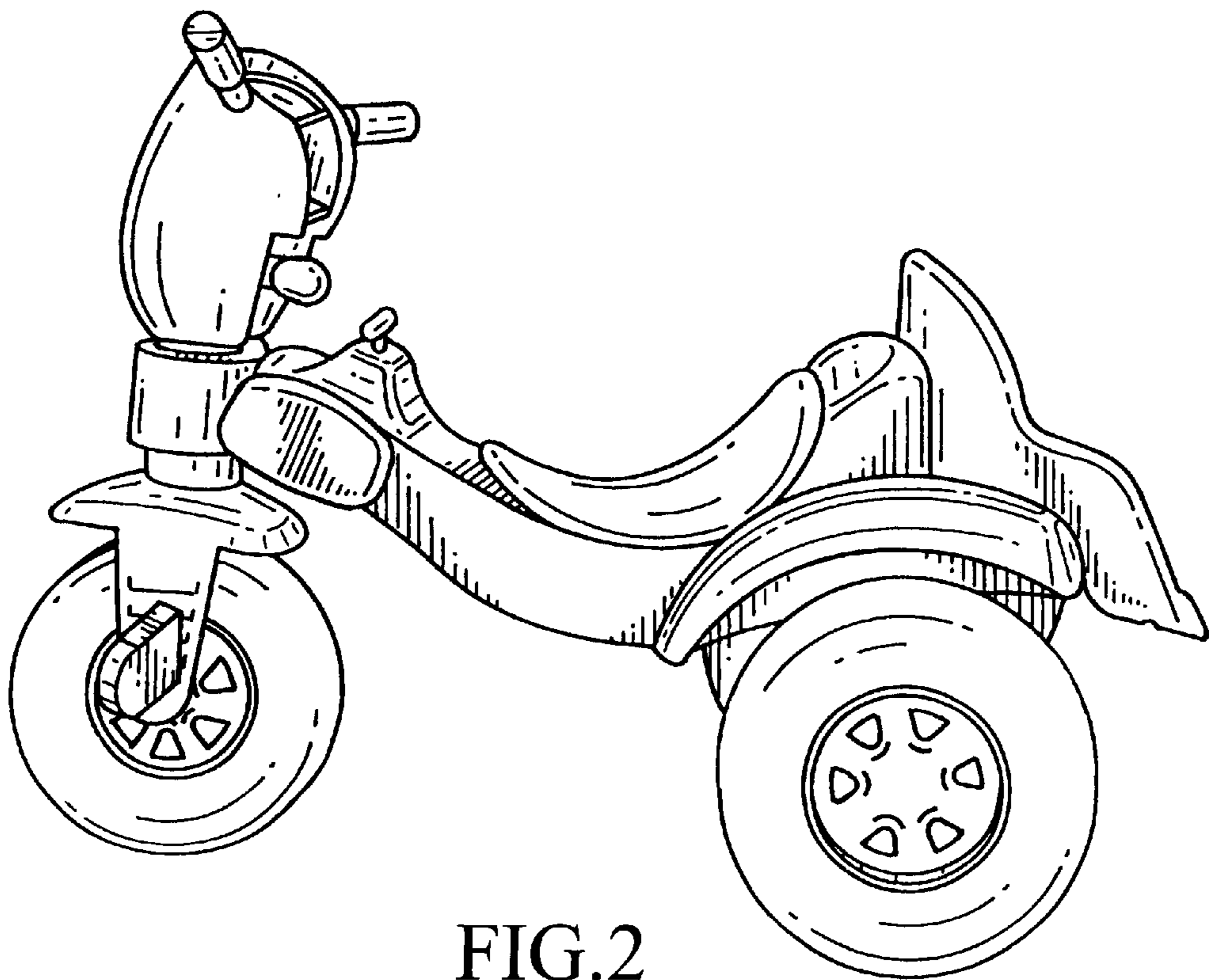

FIG. 2

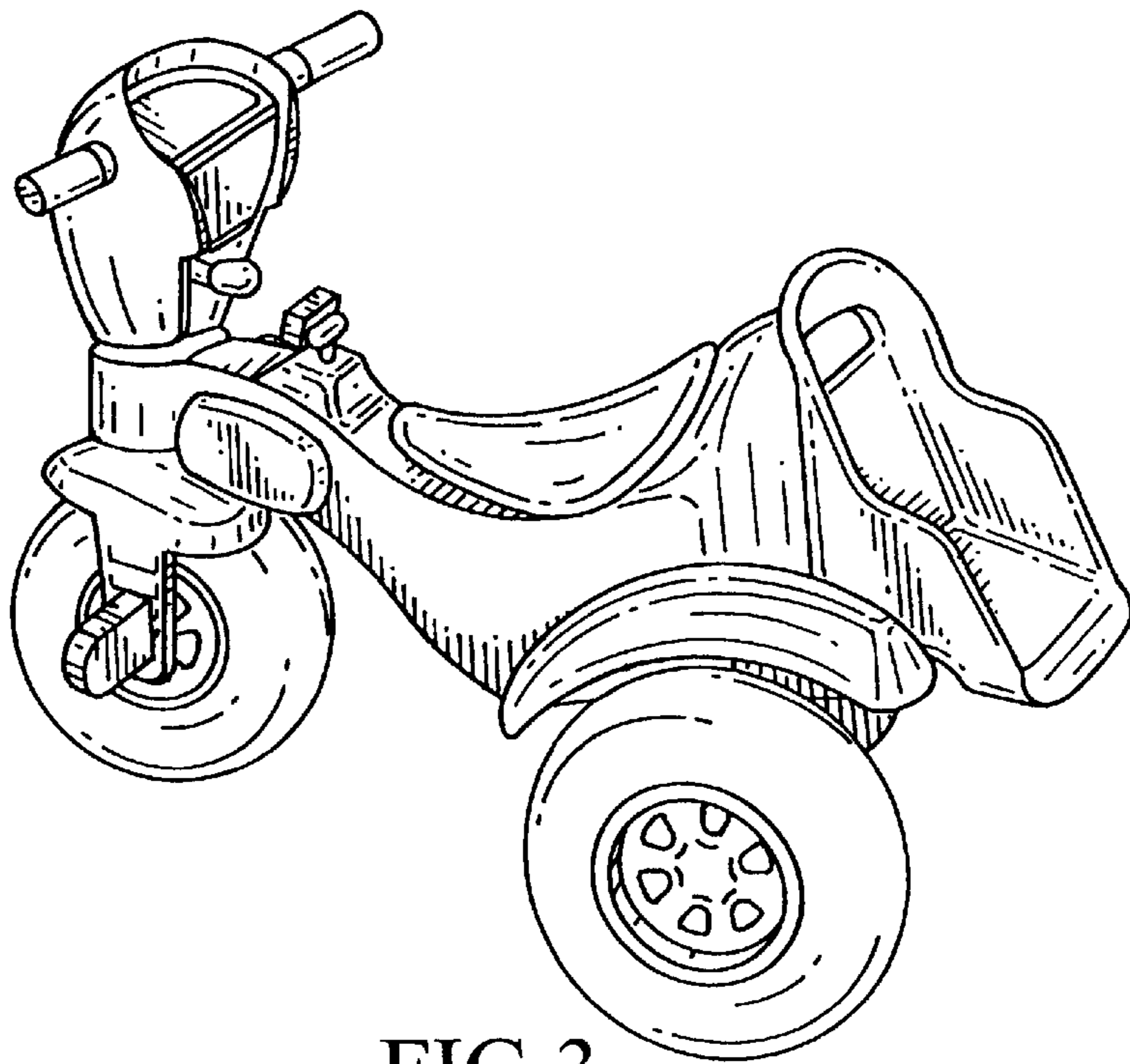

FIG.3

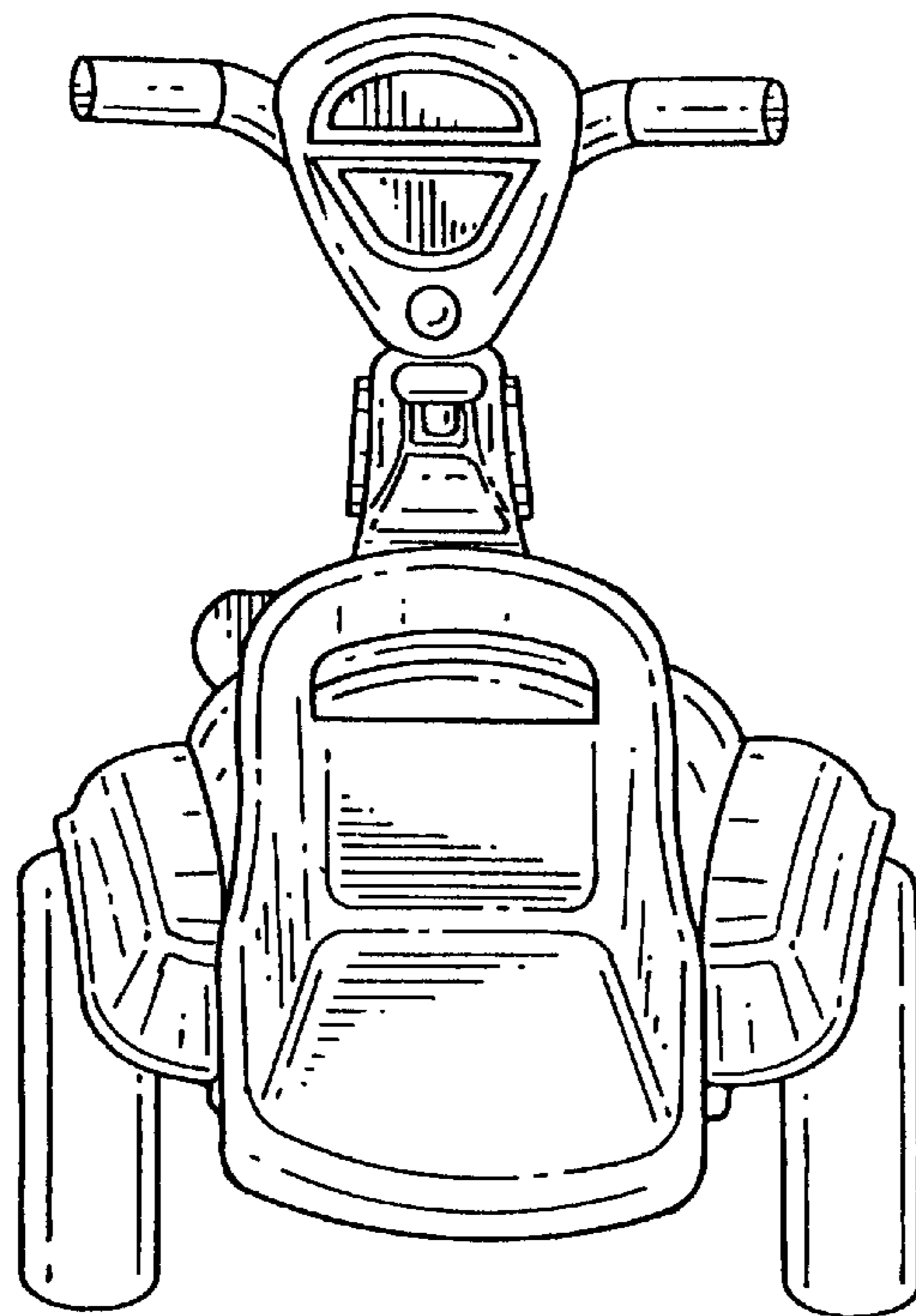

FIG.4

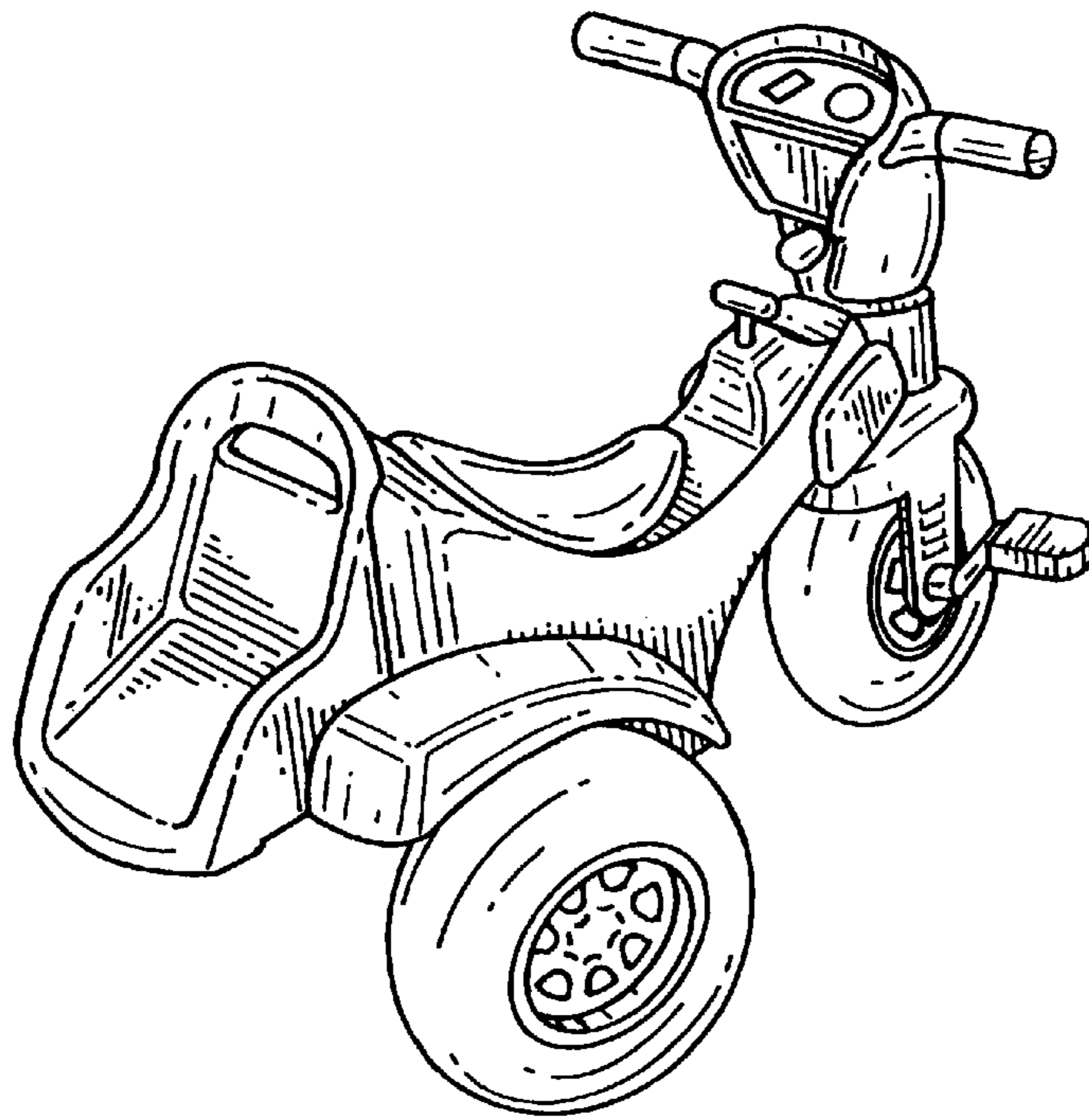

FIG. 5

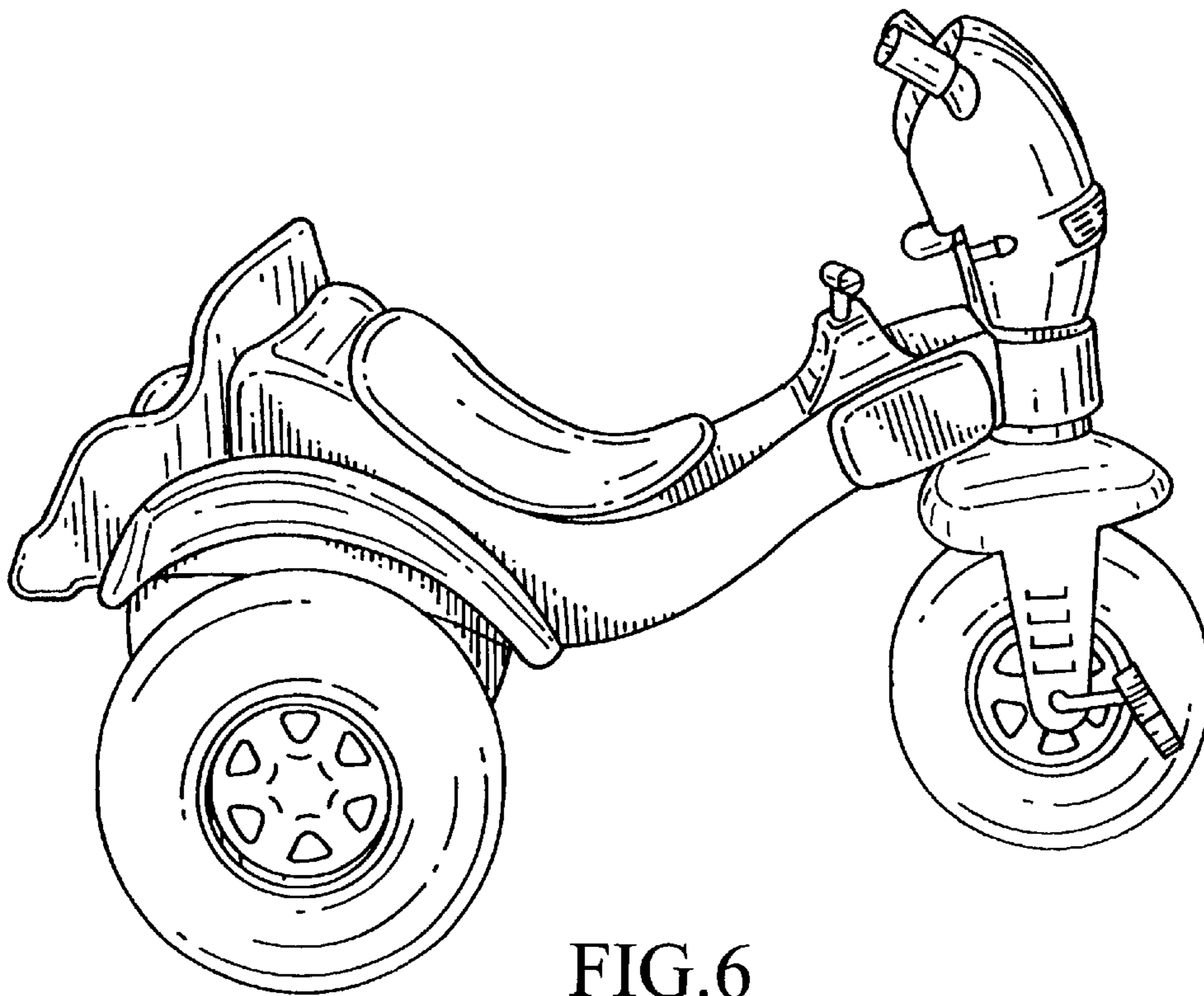

FIG. 6

UNITED STATES PATENT AND TRADEMARK OFFICE
CERTIFICATE OF CORRECTION

PATENT NO. : Des. 485,215 S
DATED : January 13, 2004
INVENTOR(S) : Joaquin Matias de Oliveira

Page 1 of 1

It is certified that error appears in the above-identified patent and that said Letters Patent is hereby corrected as shown below:

Title page.

Item [30], **Foreign Application Priority Data**, should read -- Jul. 6, 2001 (BR)
DI6101495-8 --

Signed and Sealed this

Third Day of May, 2005

A handwritten signature in black ink on a light gray dotted background. The signature reads "Jon W. Dudas" in a cursive style.

JON W. DUDAS

Director of the United States Patent and Trademark Office

UNITED STATES PATENT AND TRADEMARK OFFICE
CERTIFICATE OF CORRECTION

PATENT NO. : Des. 485,215 S
DATED : January 13, 2004
INVENTOR(S) : Joaquim Matias de Oliveira

Page 1 of 9

It is certified that error appears in the above-identified patent and that said Letters Patent is hereby corrected as shown below:

Title page.

Item [30], **Foreign Application Priority Data**, should read
-- Jul. 6, 2001 (BR) DI6101495-8 --.

Drawings.

Add FIGs. 7-16 as attached.

Signed and Sealed this

Twenty-fourth Day of January, 2006

A handwritten signature in black ink on a light gray dotted background. The signature reads "Jon W. Dudas" in a cursive style.

JON W. DUDAS

Director of the United States Patent and Trademark Office

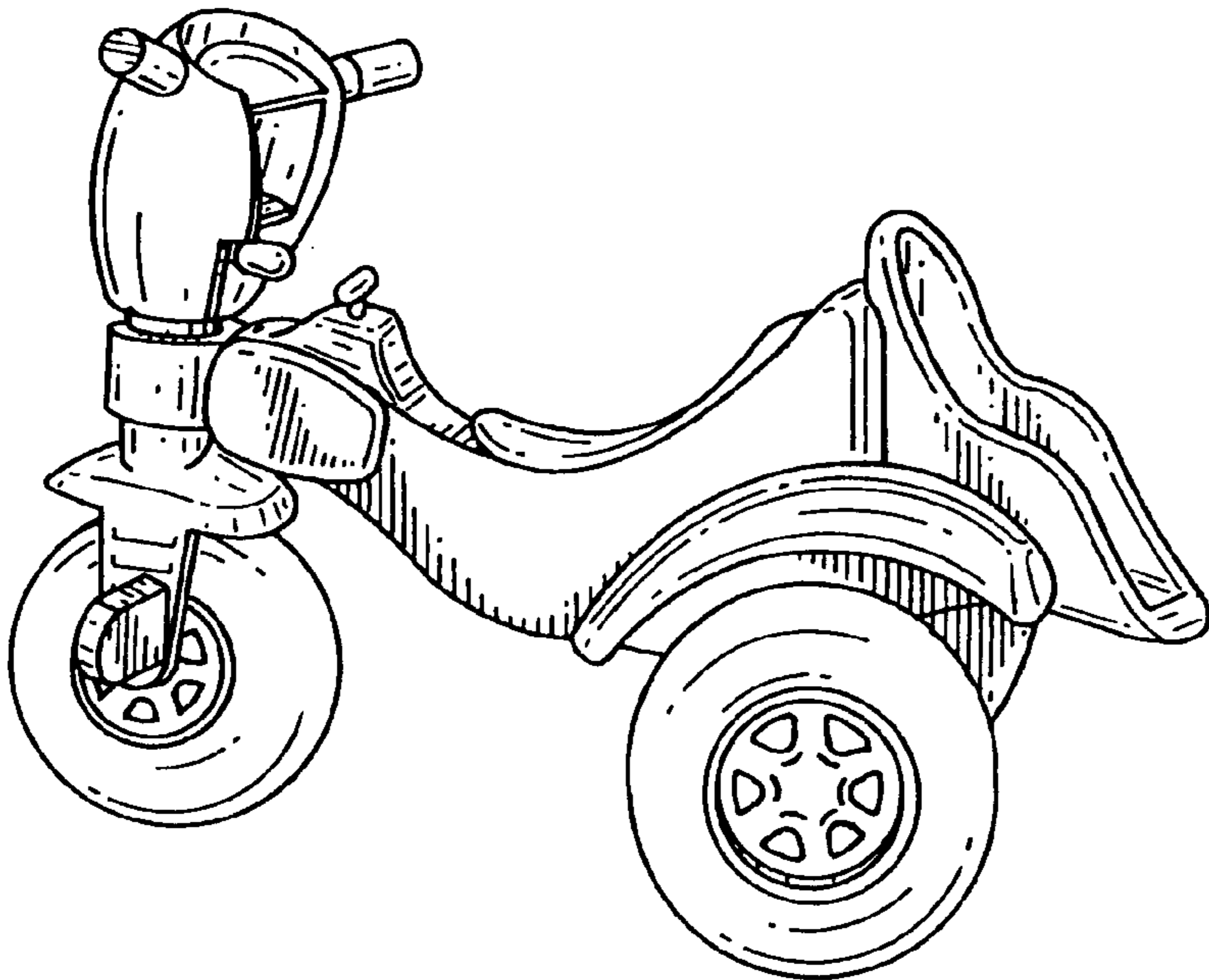

FIG. 1

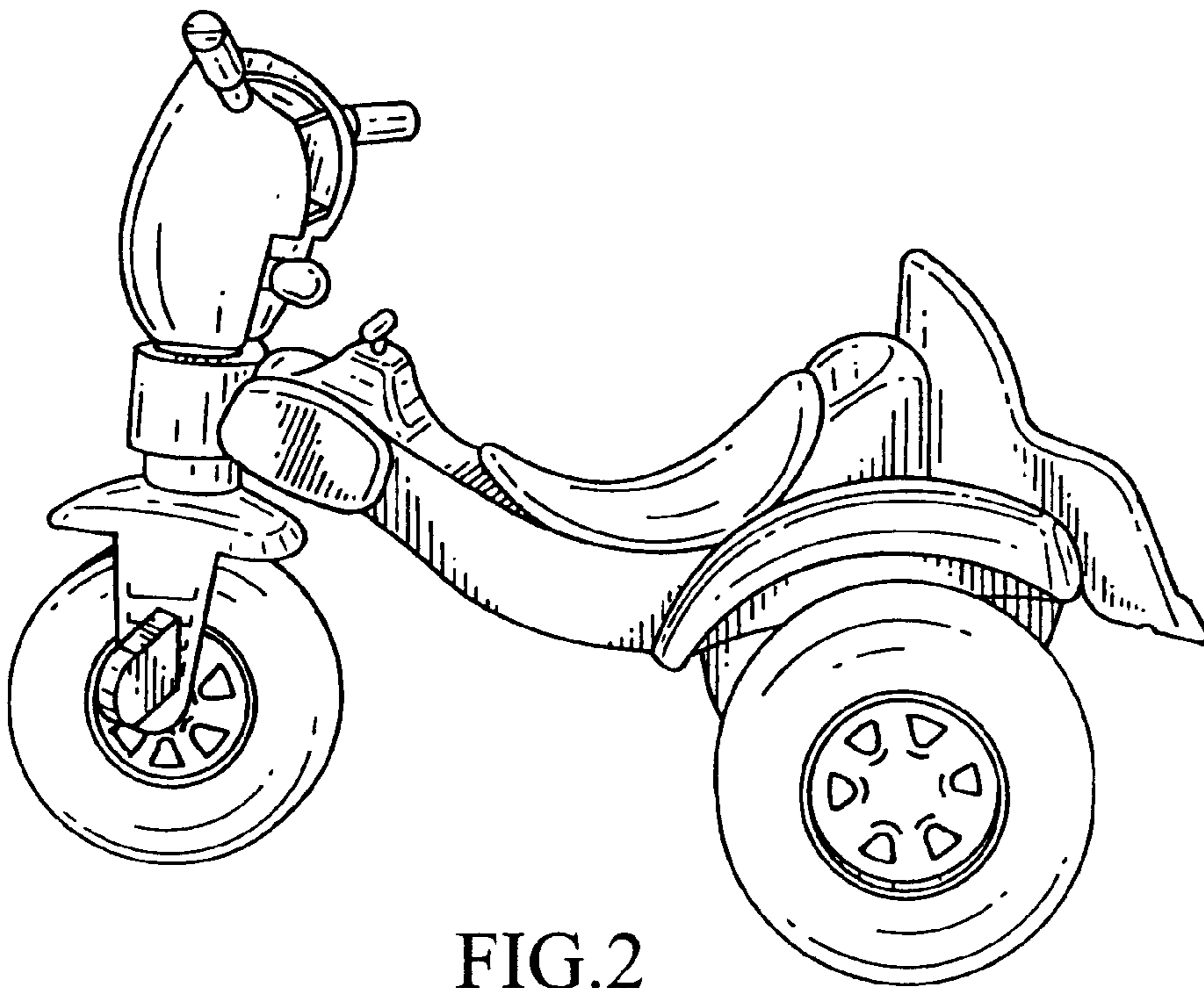

FIG. 2

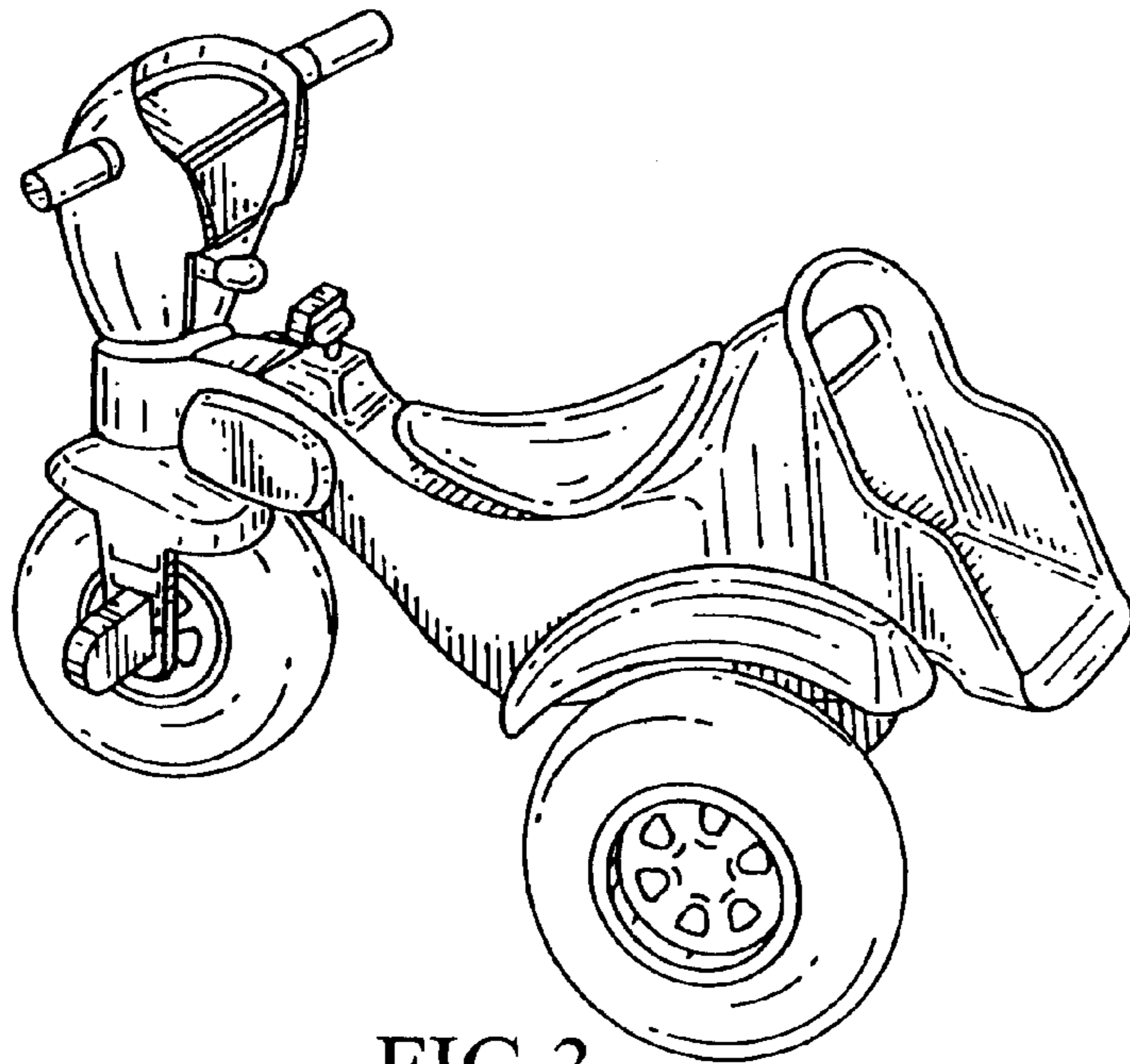

FIG. 3

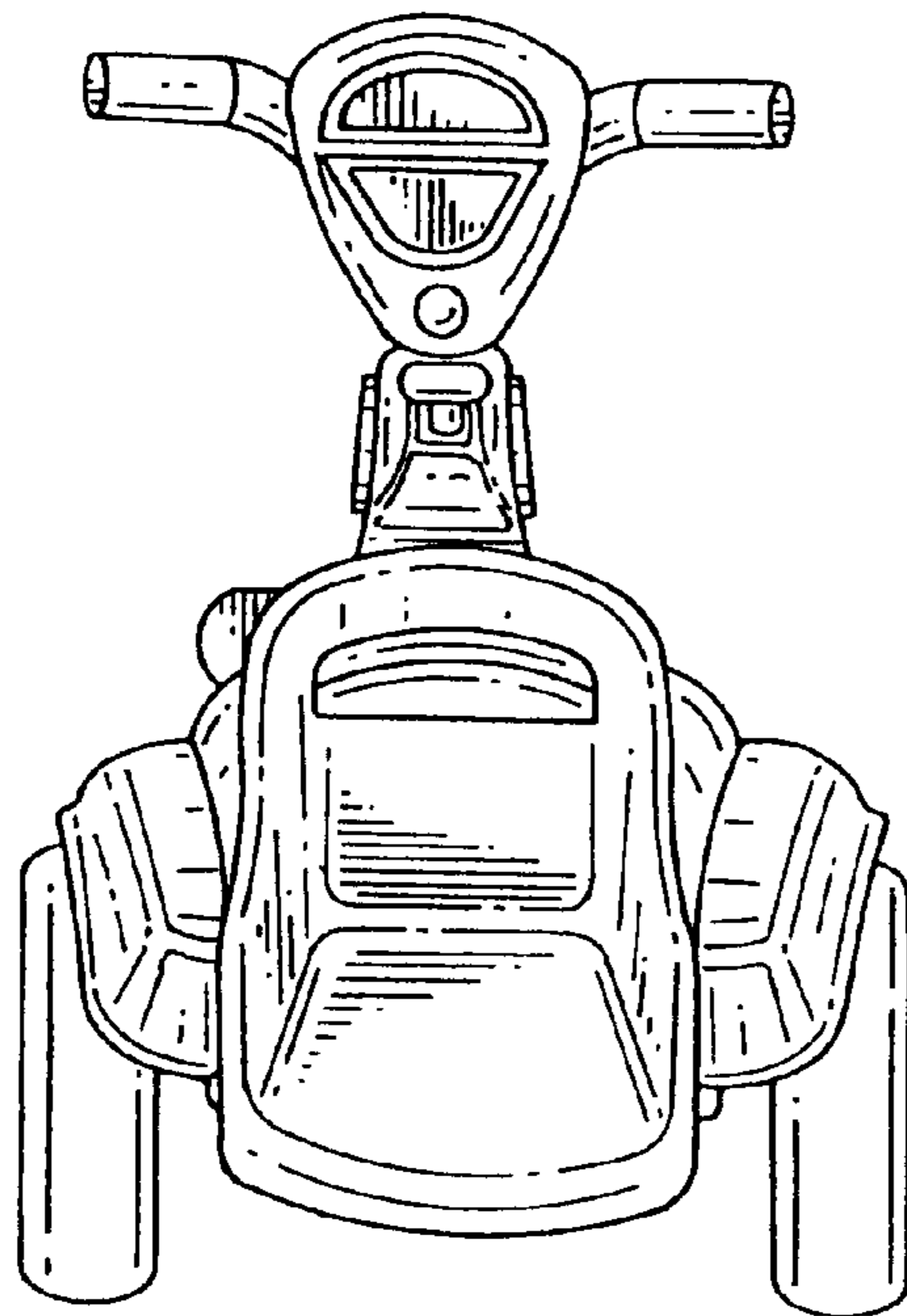

FIG. 4

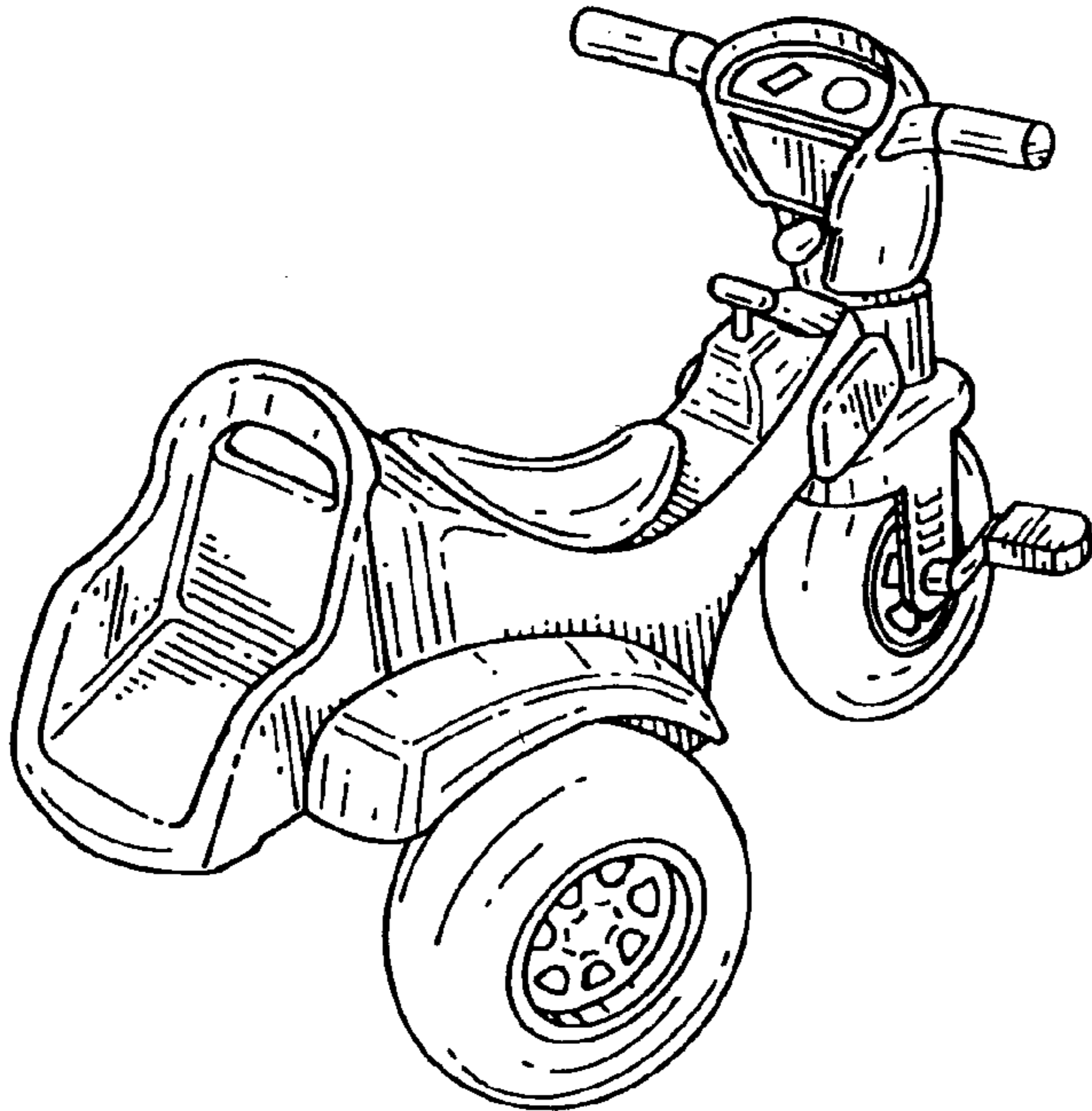

FIG. 5

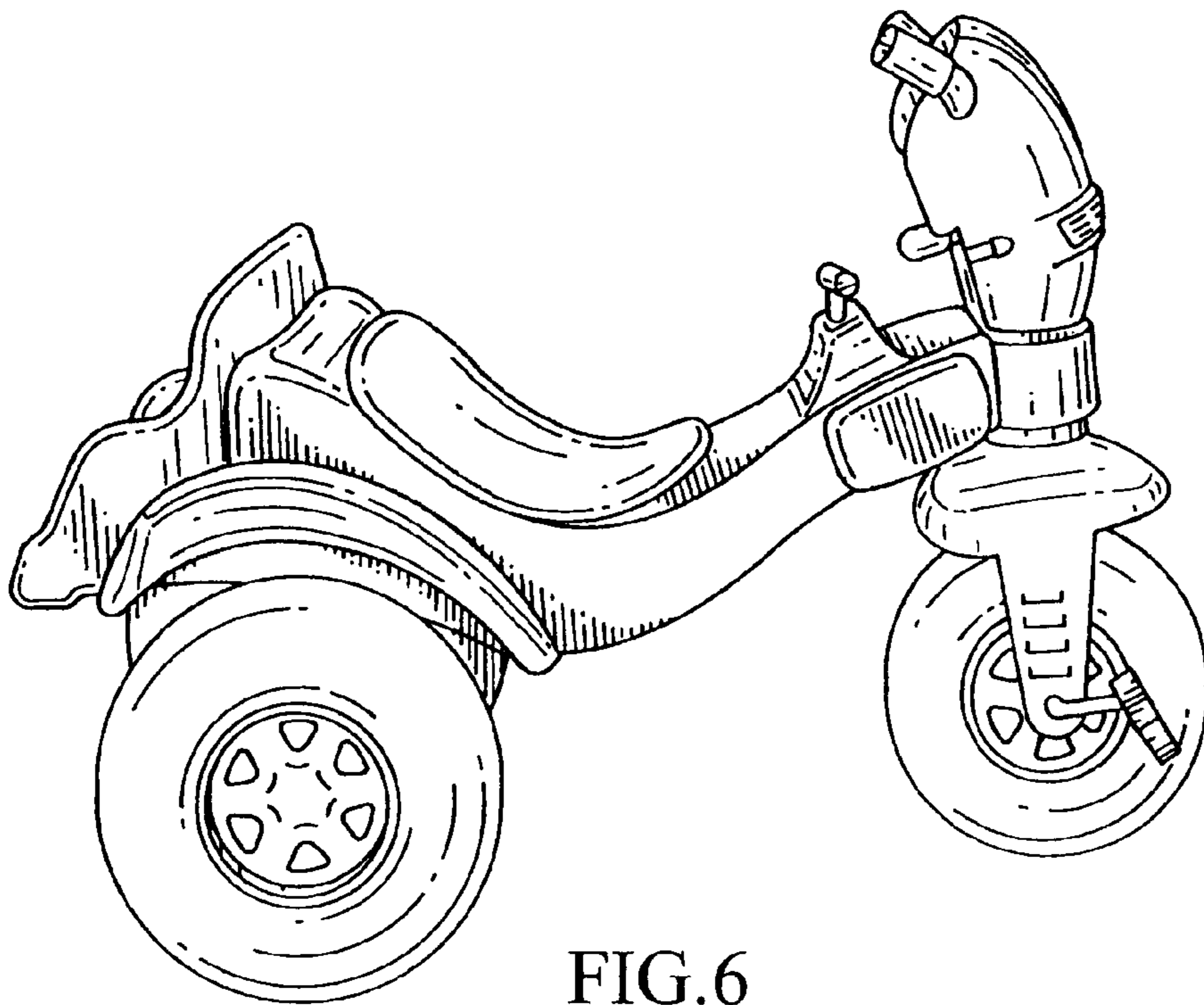

FIG. 6

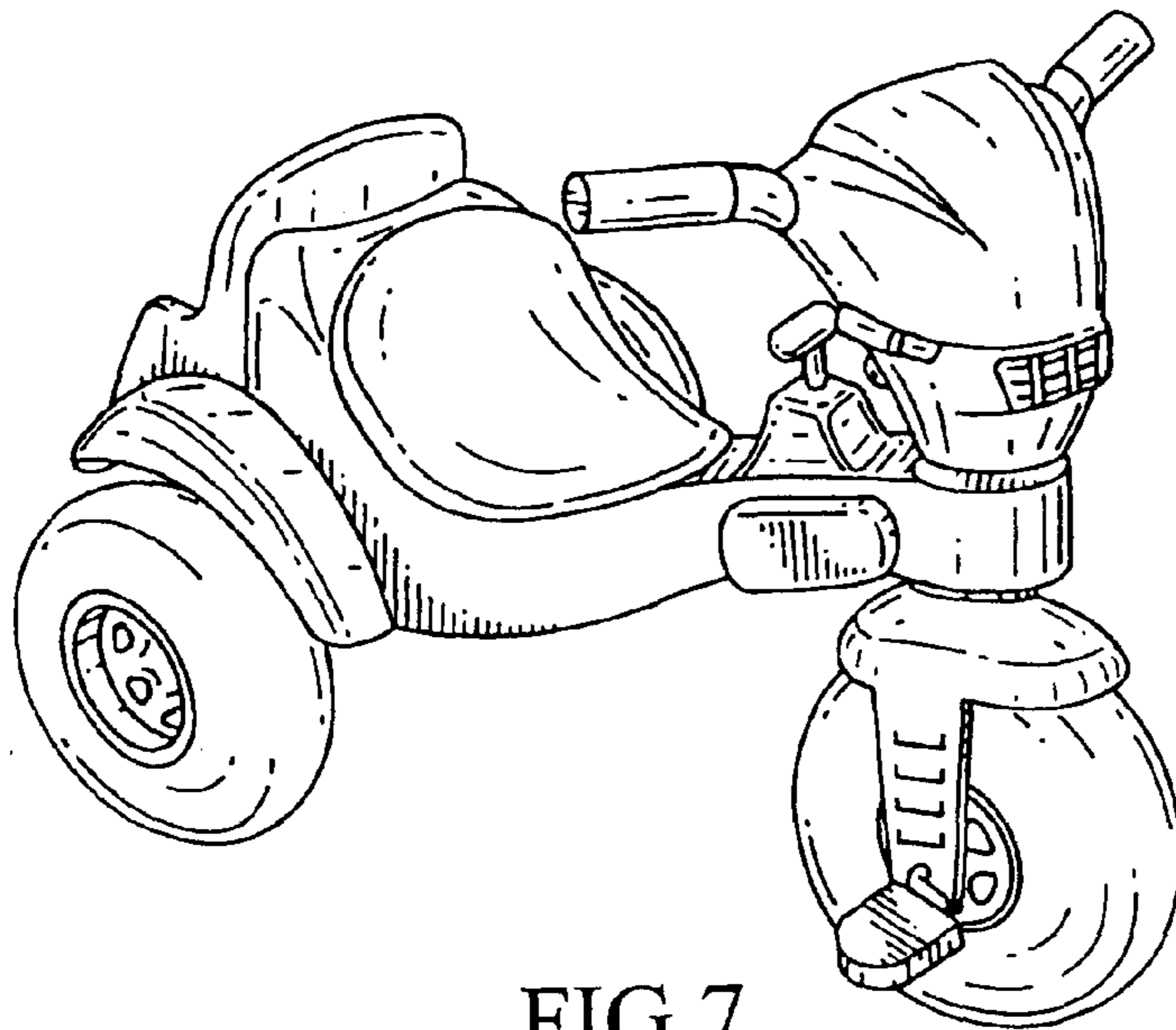

FIG. 7

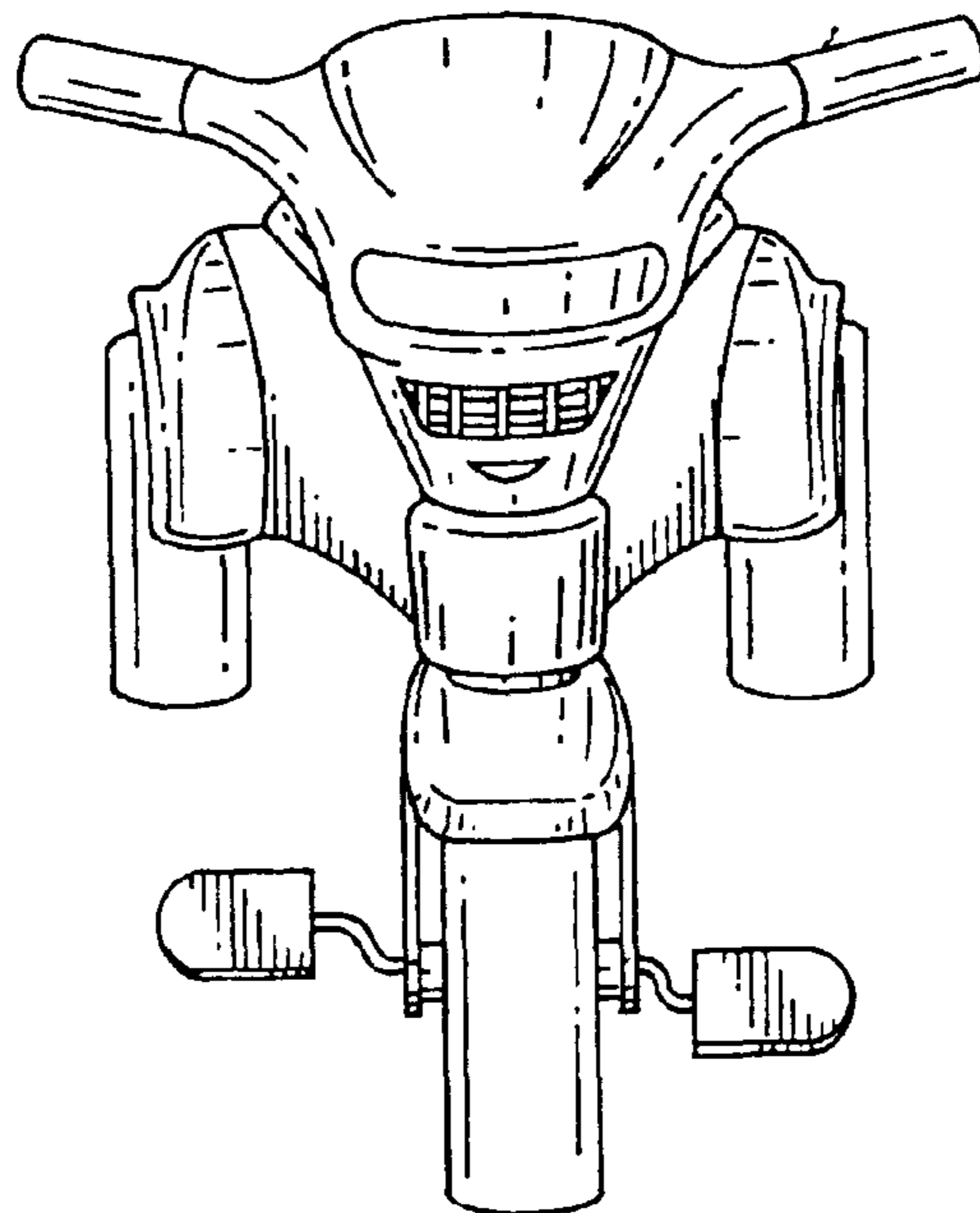

FIG. 8

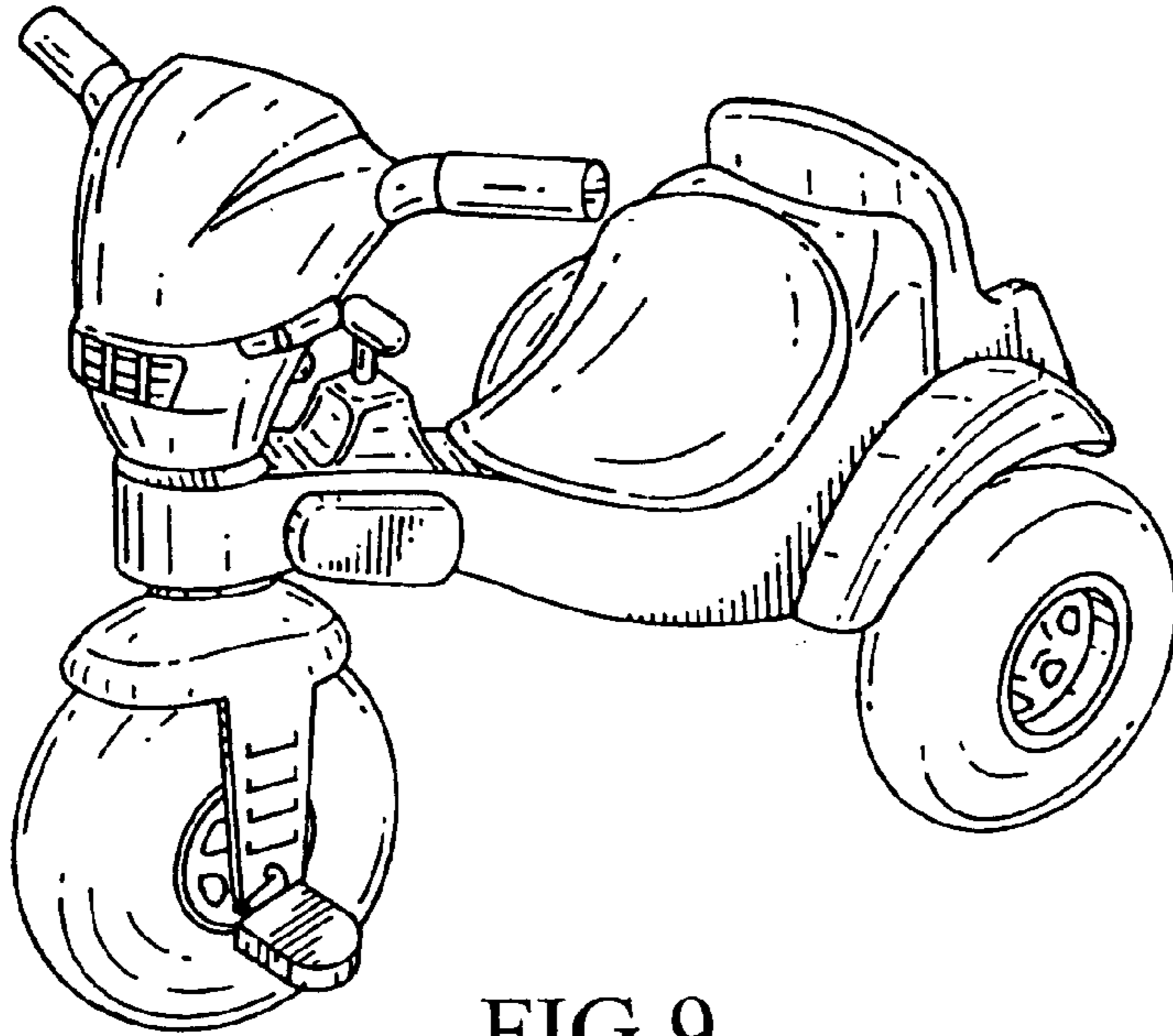

FIG. 9

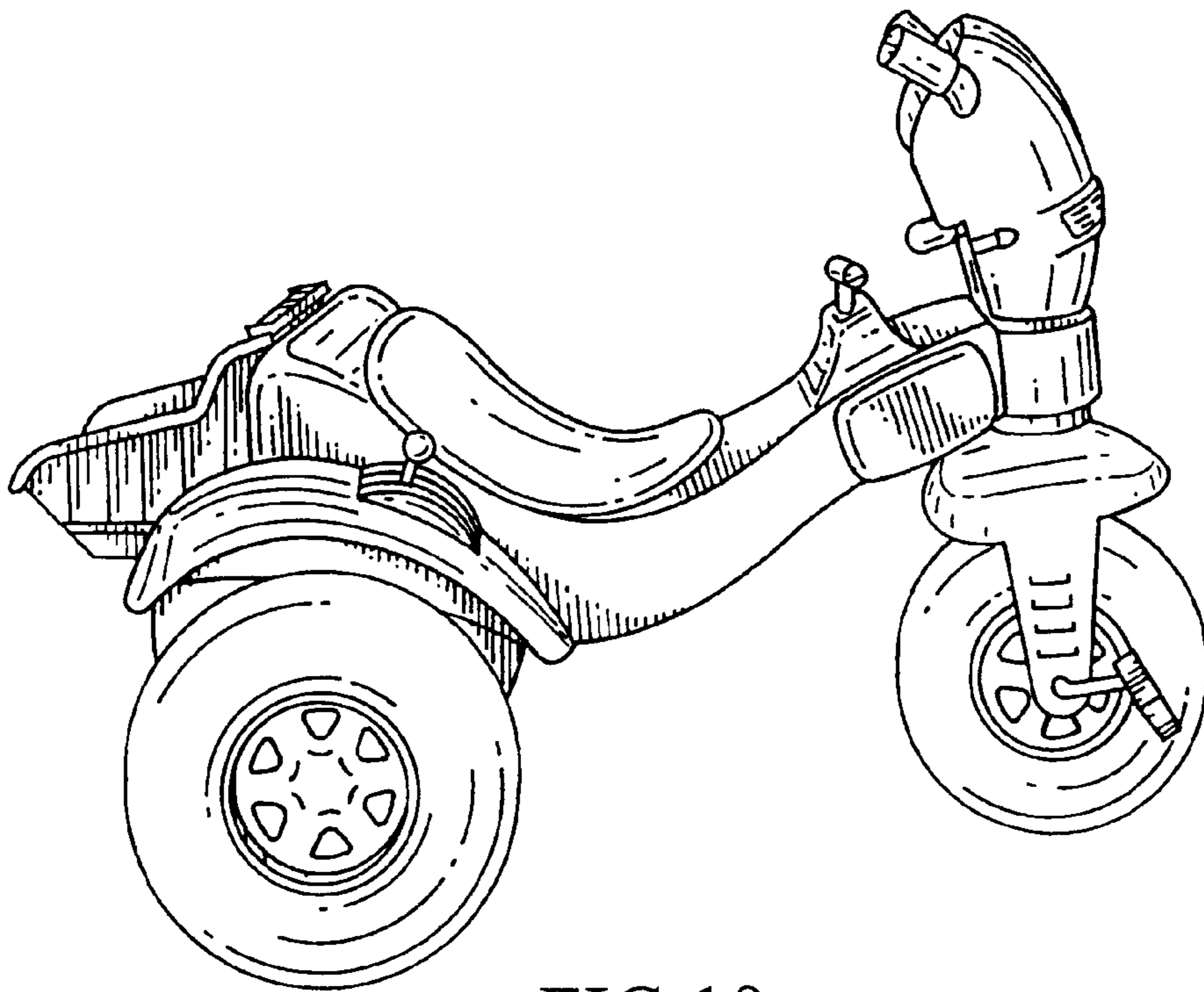

FIG. 10

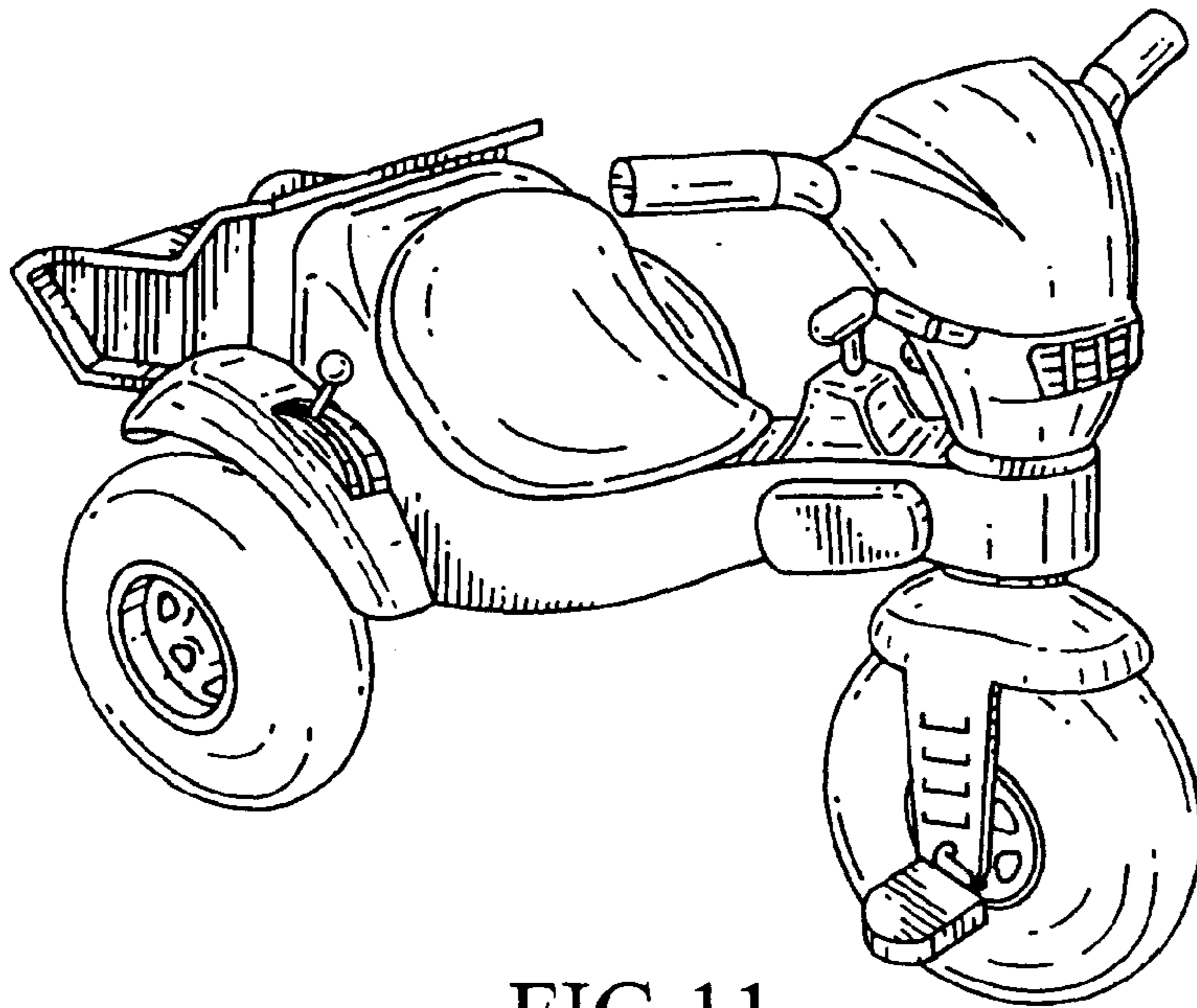

FIG. 11

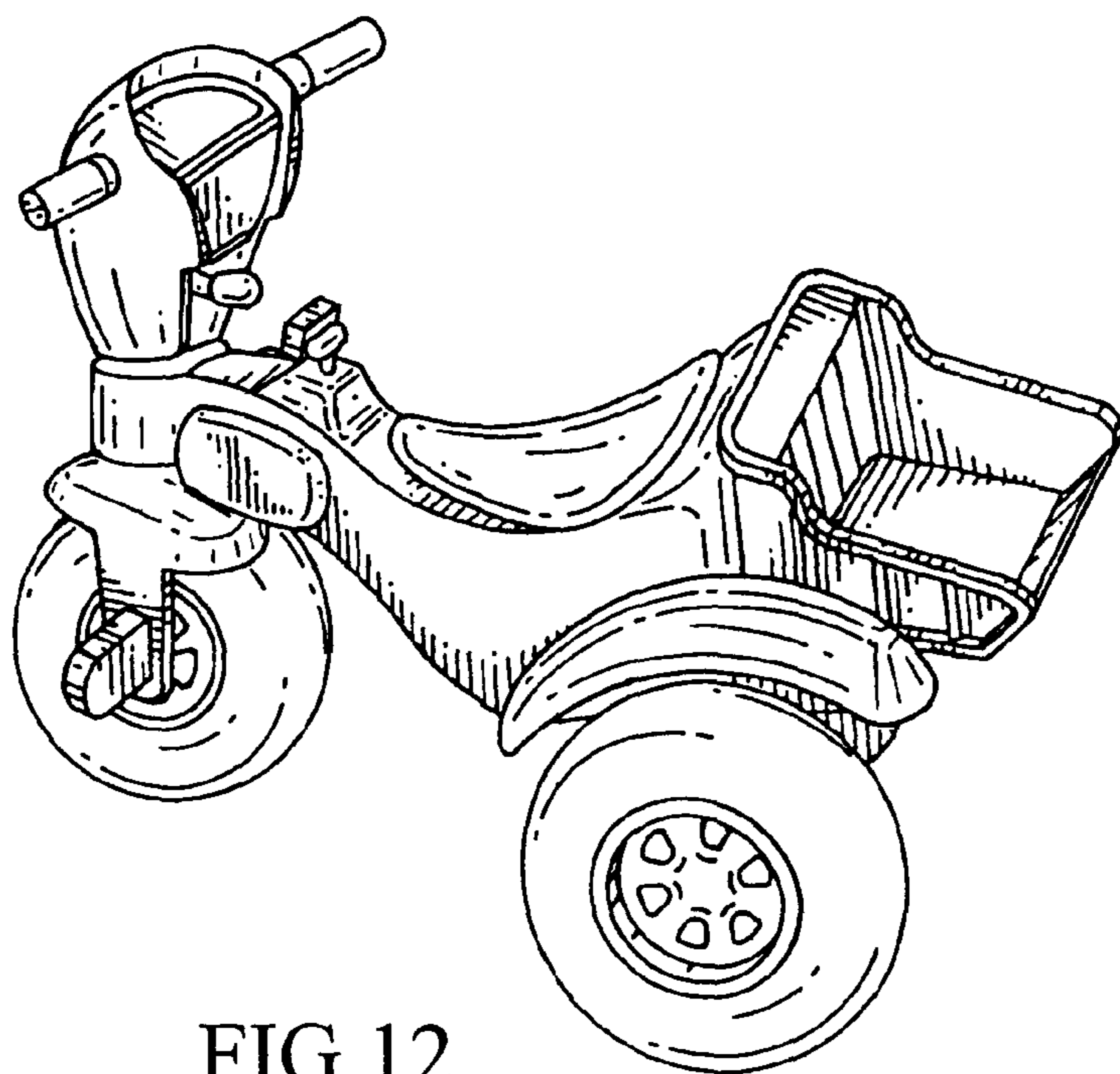

FIG. 12

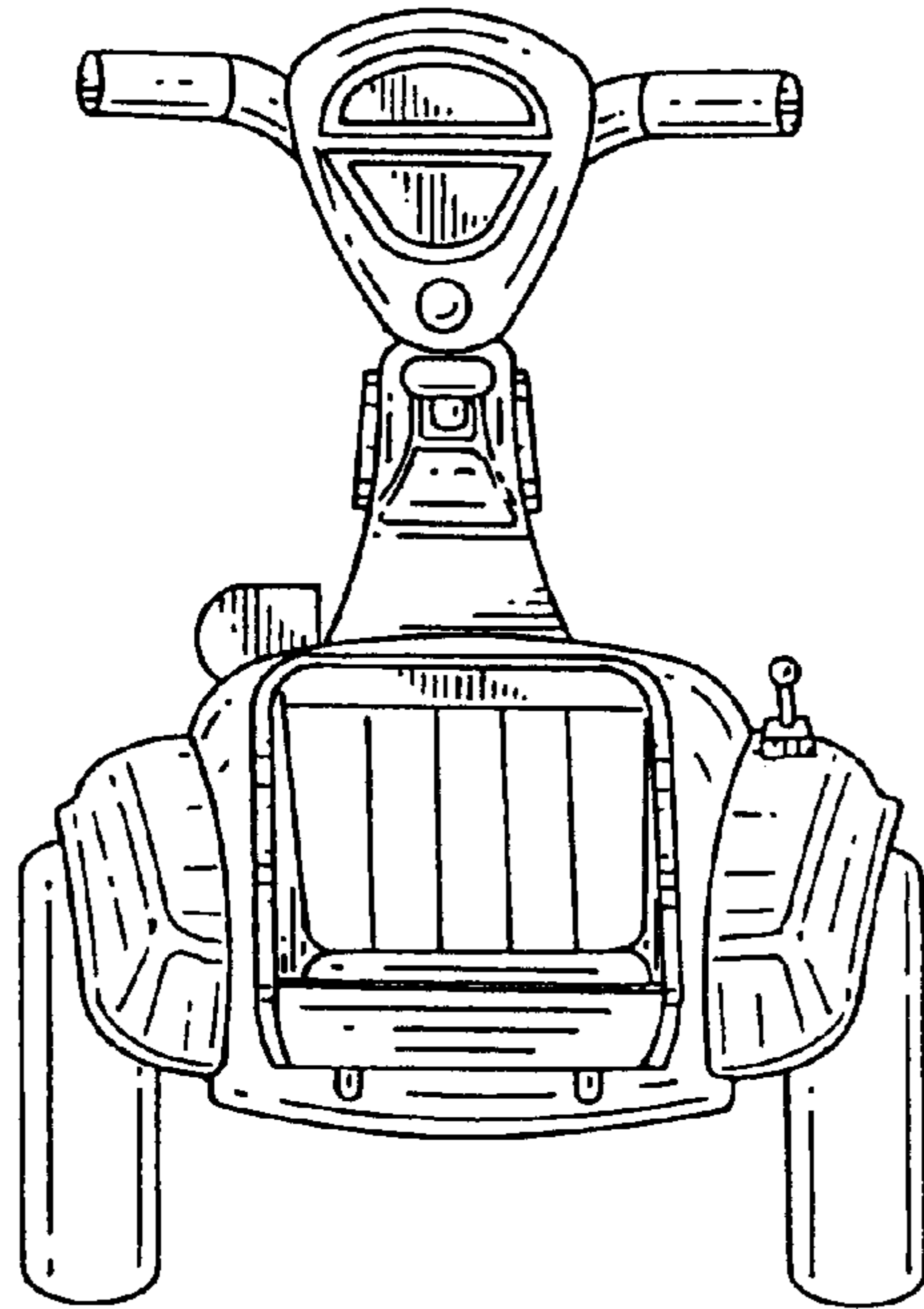

FIG.13

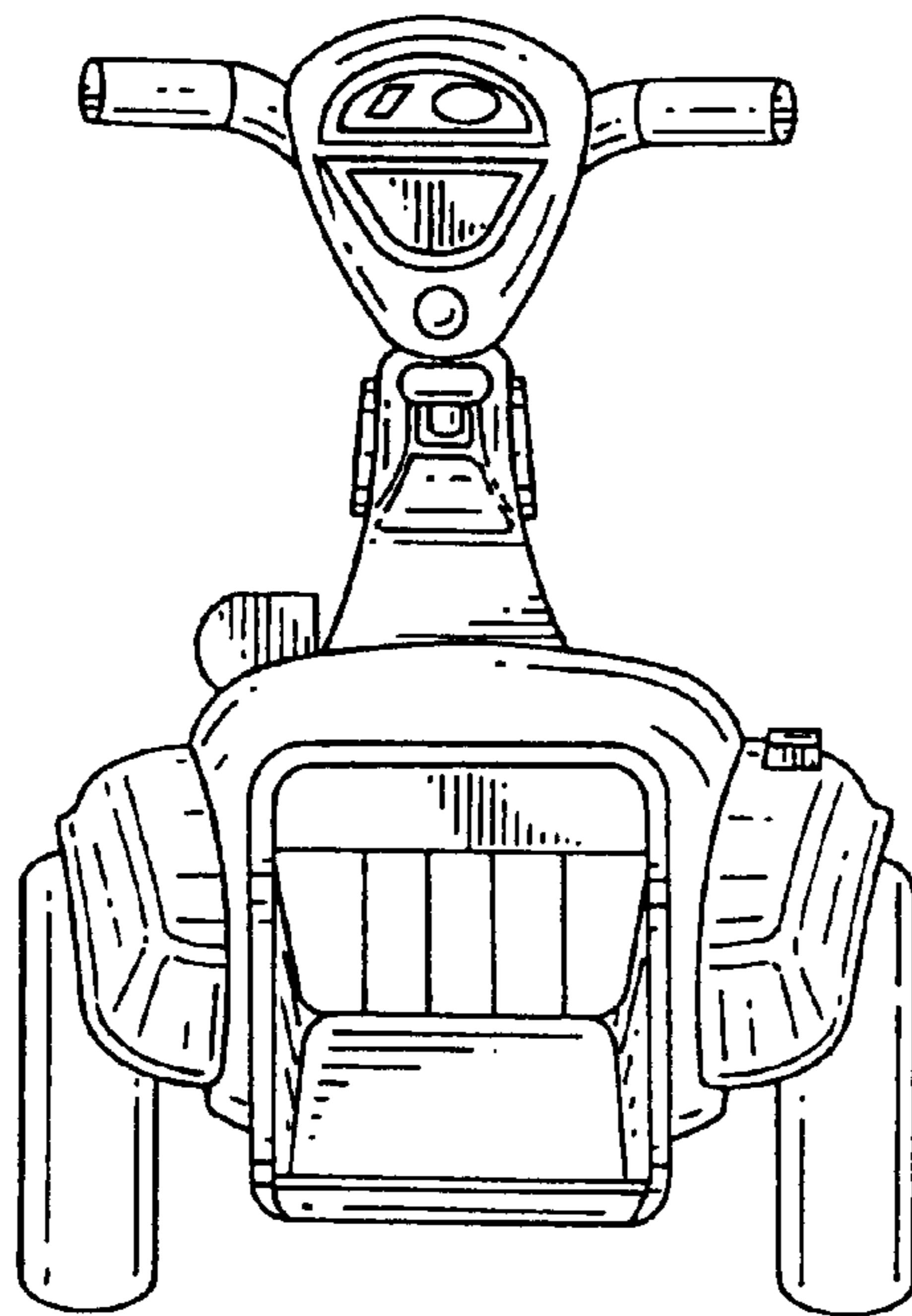

FIG 14

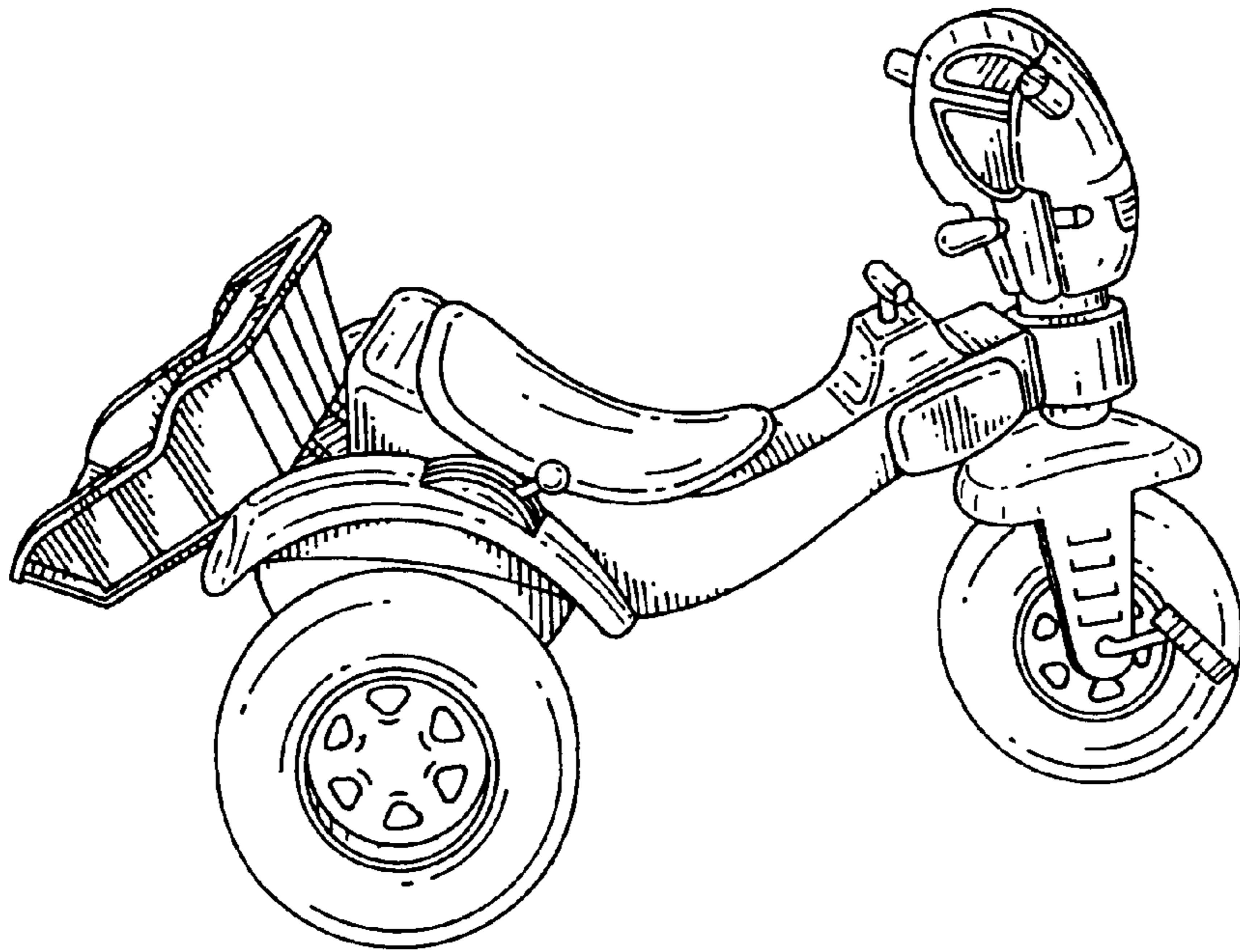

FIG. 15

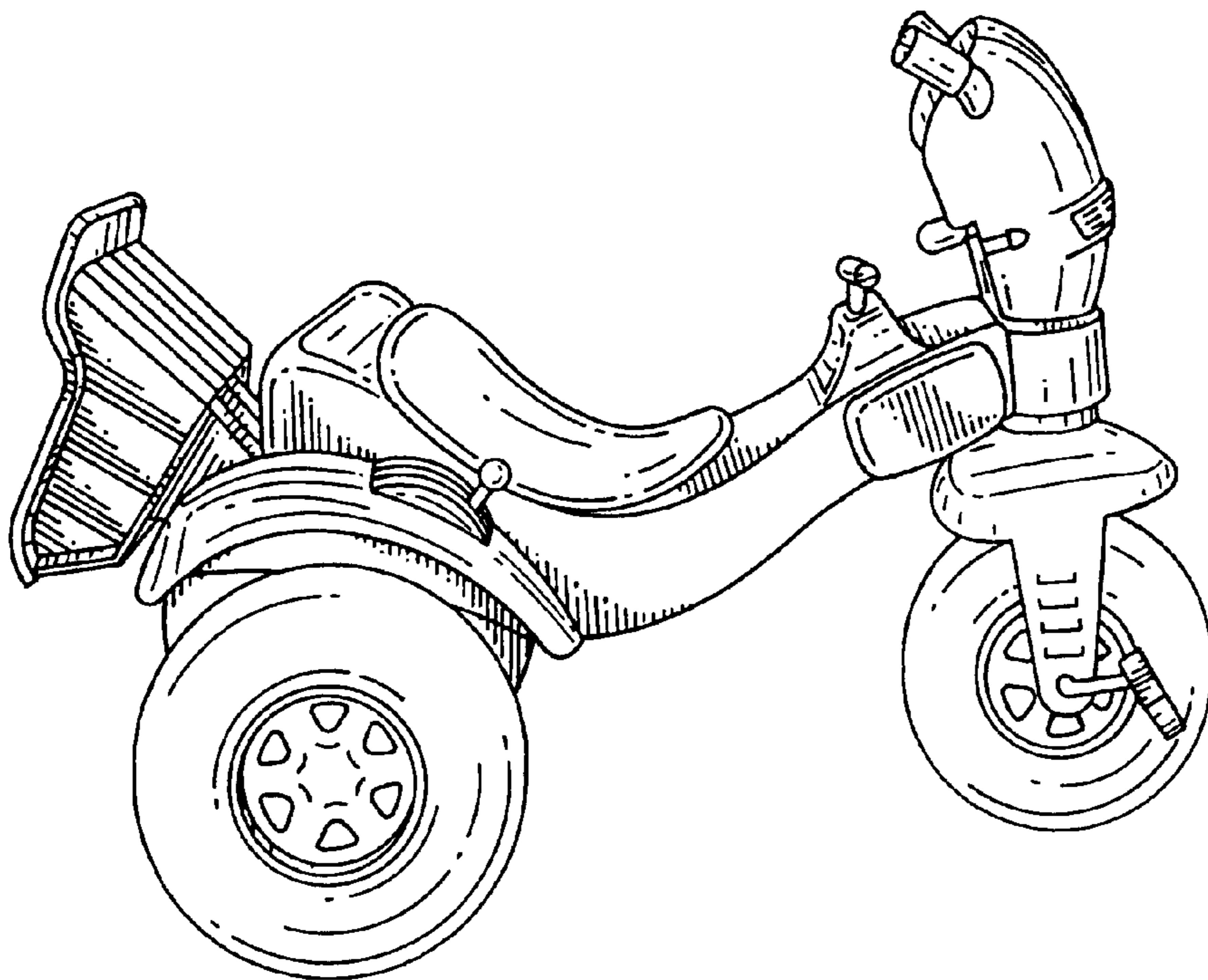

FIG 16