



US00D485212S

(12) **United States Design Patent**
Wu

(10) **Patent No.:** **US D485,212 S**

(45) **Date of Patent:** **** Jan. 13, 2004**

(54) **ALL TERRAIN VEHICLE**

D464,291 S * 10/2002 Wu D12/107

(75) **Inventor:** **Wen-Yung Wu**, Kaohsiung (TW)

* cited by examiner

(73) **Assignee:** **Kwang Yang Motor Co., Ltd.**,
Kaohsiung (TW)

Primary Examiner—Alan P. Douglas

Assistant Examiner—Linda Brooks

(**) **Term:** **14 Years**

(74) *Attorney, Agent, or Firm*—Leong C. Lei

(21) **Appl. No.:** **29/176,088**

(57) **CLAIM**

The ornamental design for an all terrain vehicle, as shown and described.

(22) **Filed:** **Feb. 19, 2003**

DESCRIPTION

(51) **LOC (7) Cl.** **12-11**

FIG. 1 is perspective view of an all terrain vehicle showing my new design;

(52) **U.S. Cl.** **D12/107**

FIG. 2 is a front side elevation view thereof;

(58) **Field of Search** D12/87, 107; 180/225,
180/229, 233, 311, 312, 315

FIG. 3 is a rear side elevation view thereof;

FIG. 4 is a left side elevation view thereof;

FIG. 5 is a right side elevation view thereof;

FIG. 6 is a top plan view thereof; and,

FIG. 7 is a bottom plan view thereof.

(56) **References Cited**

U.S. PATENT DOCUMENTS

D327,457 S * 6/1992 Saito D12/107

D458,562 S * 6/2002 Kalhok et al. D12/107

1 Claim, 4 Drawing Sheets

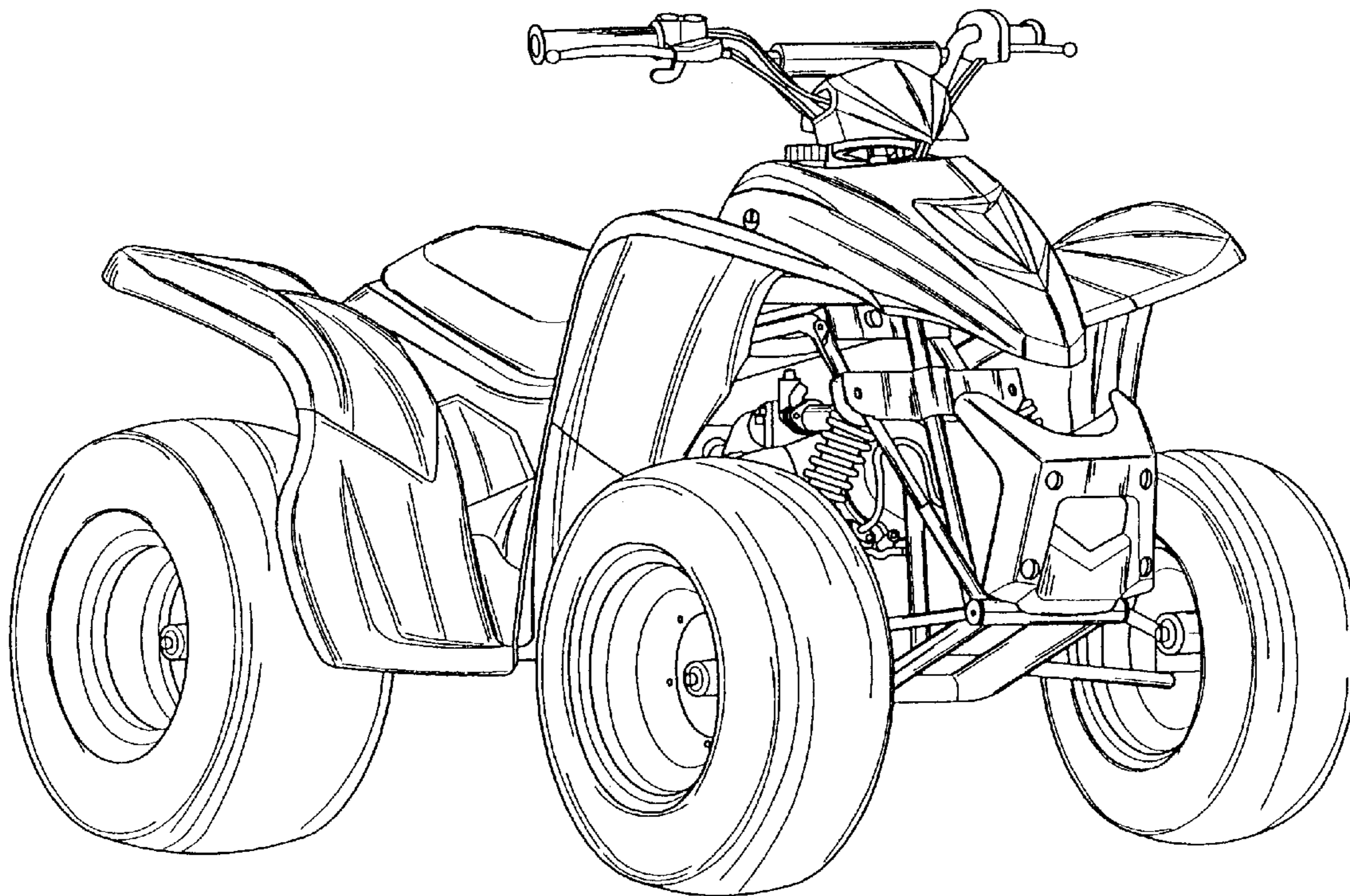

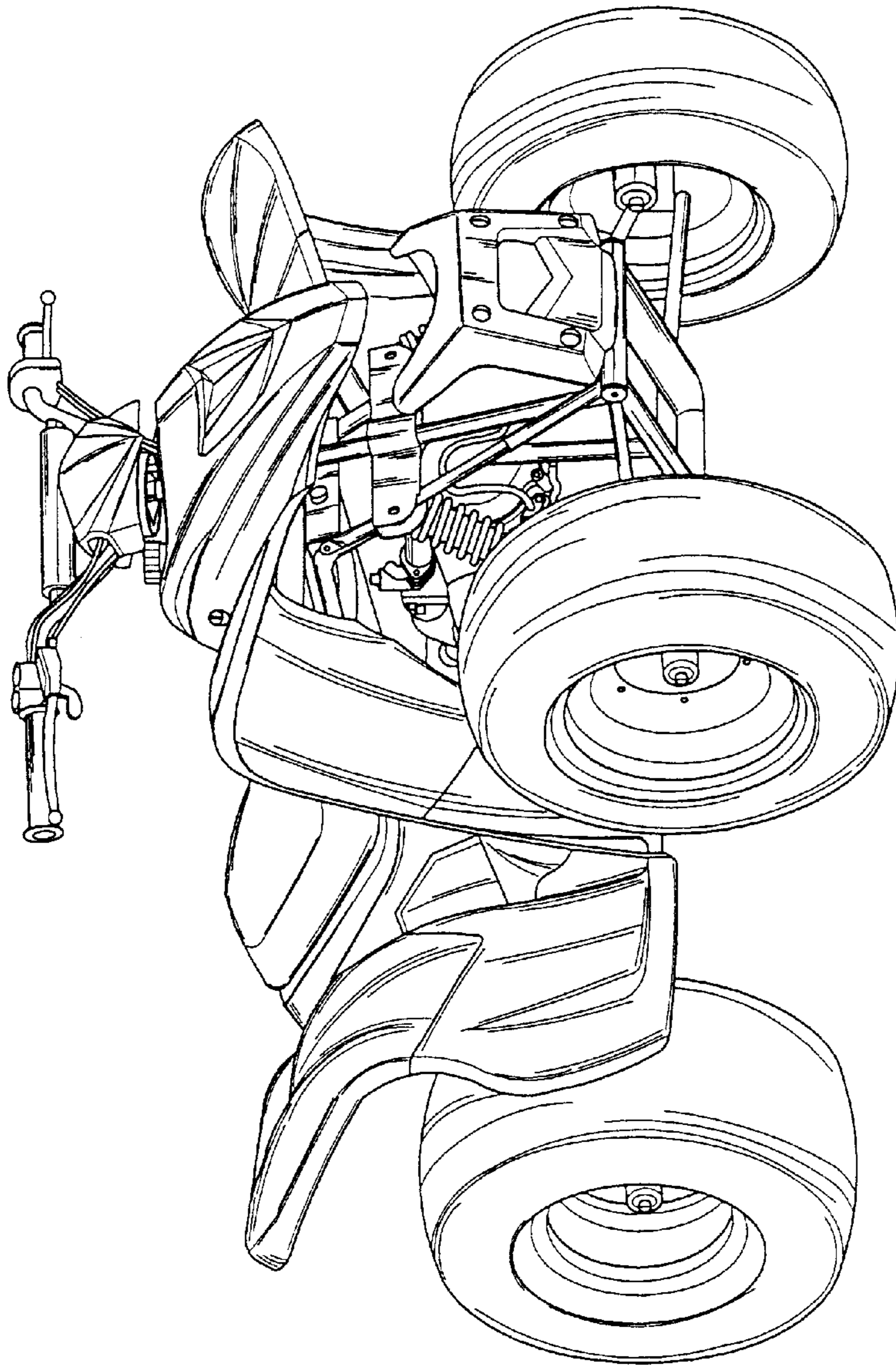

FIG. 1

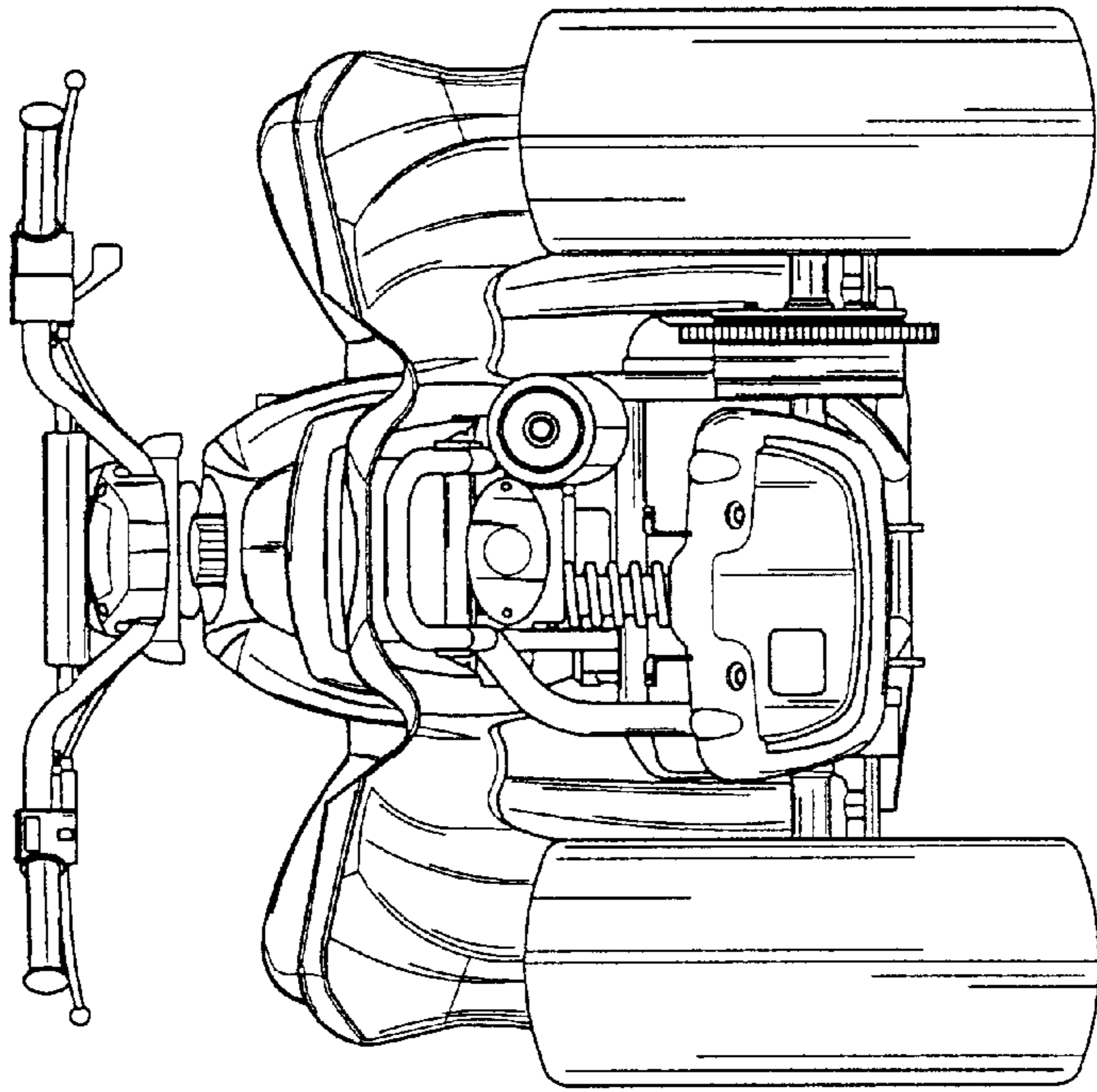

FIG. 3

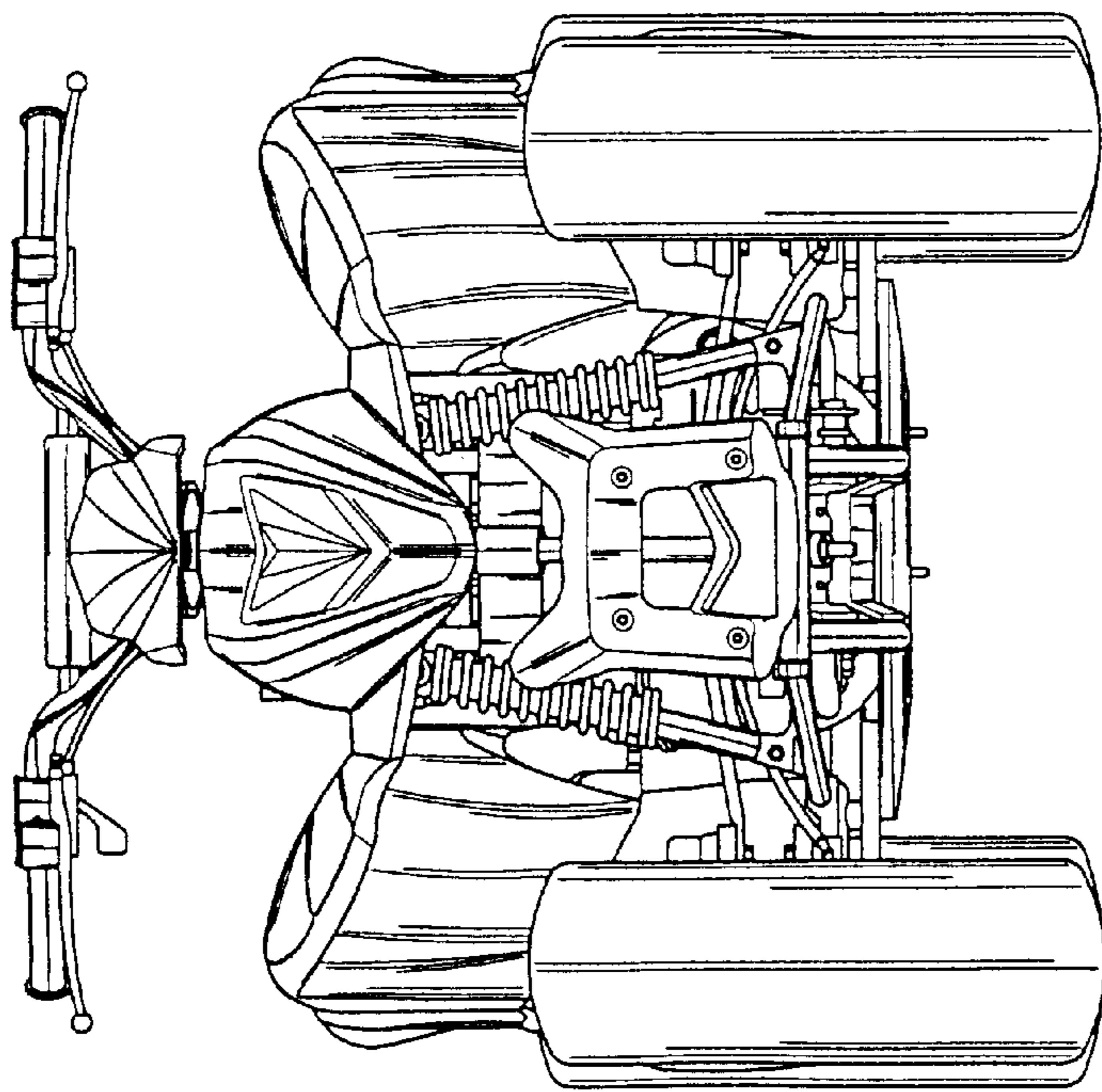

FIG. 2

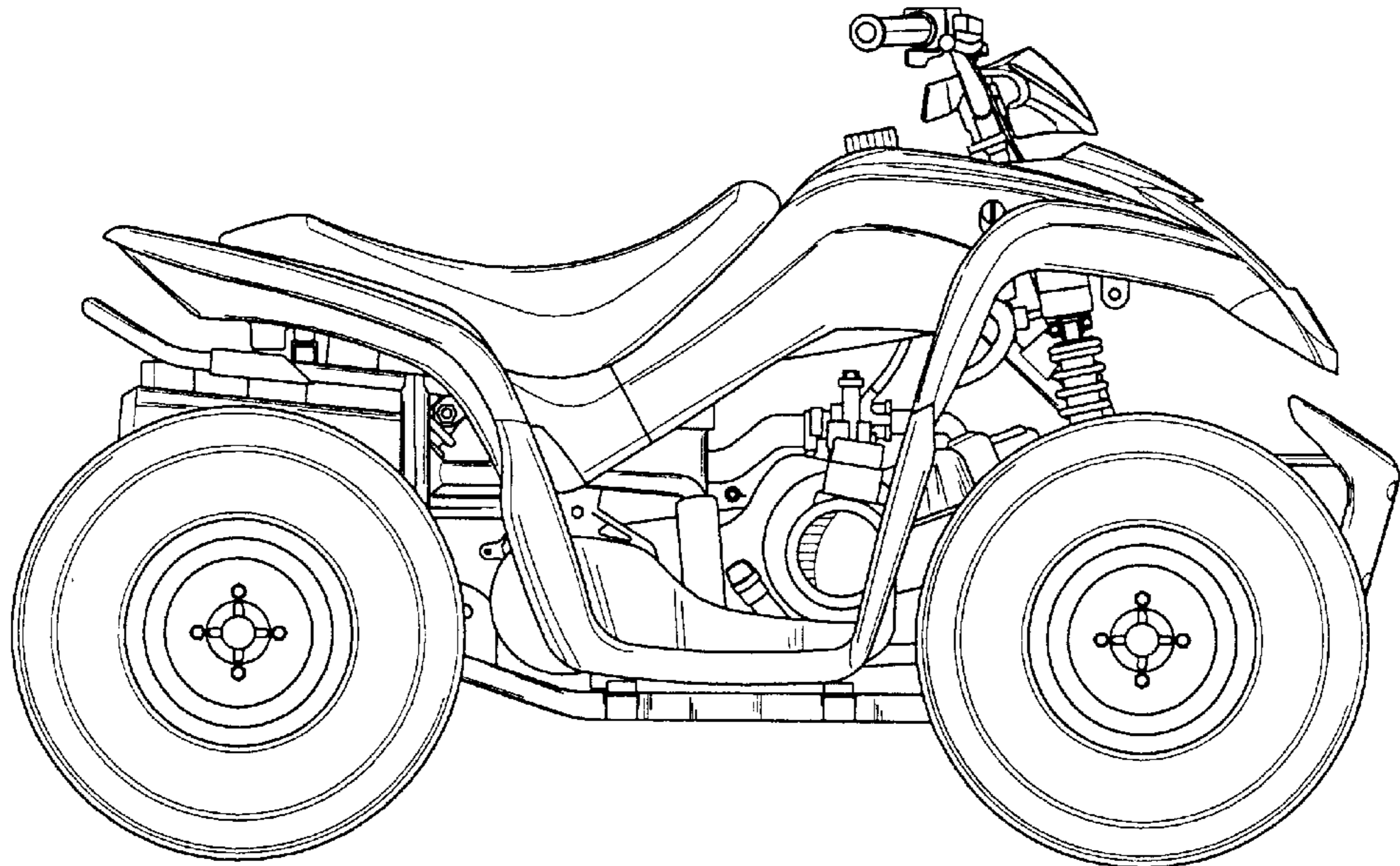

FIG. 4

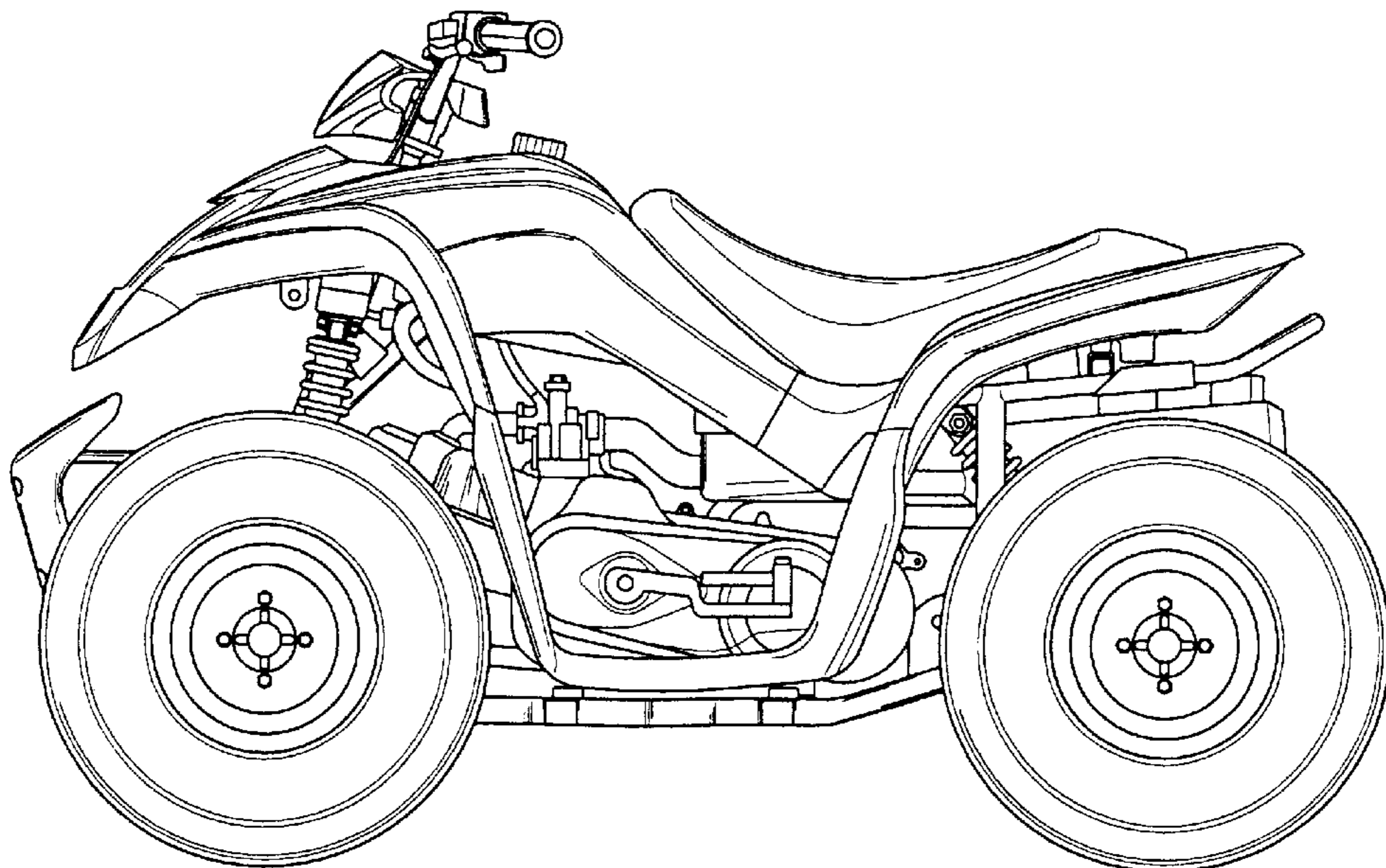

FIG. 5

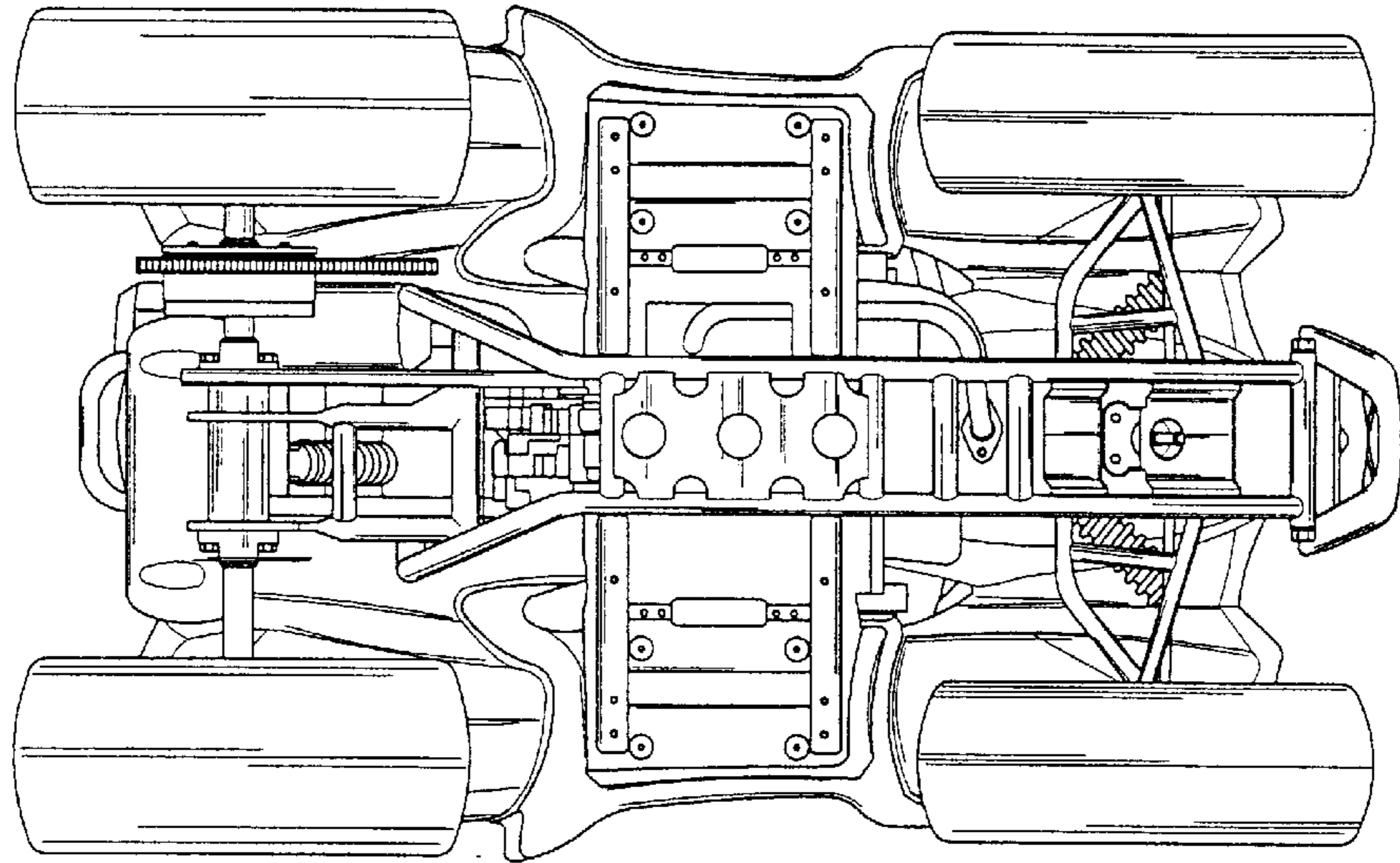

FIG. 6

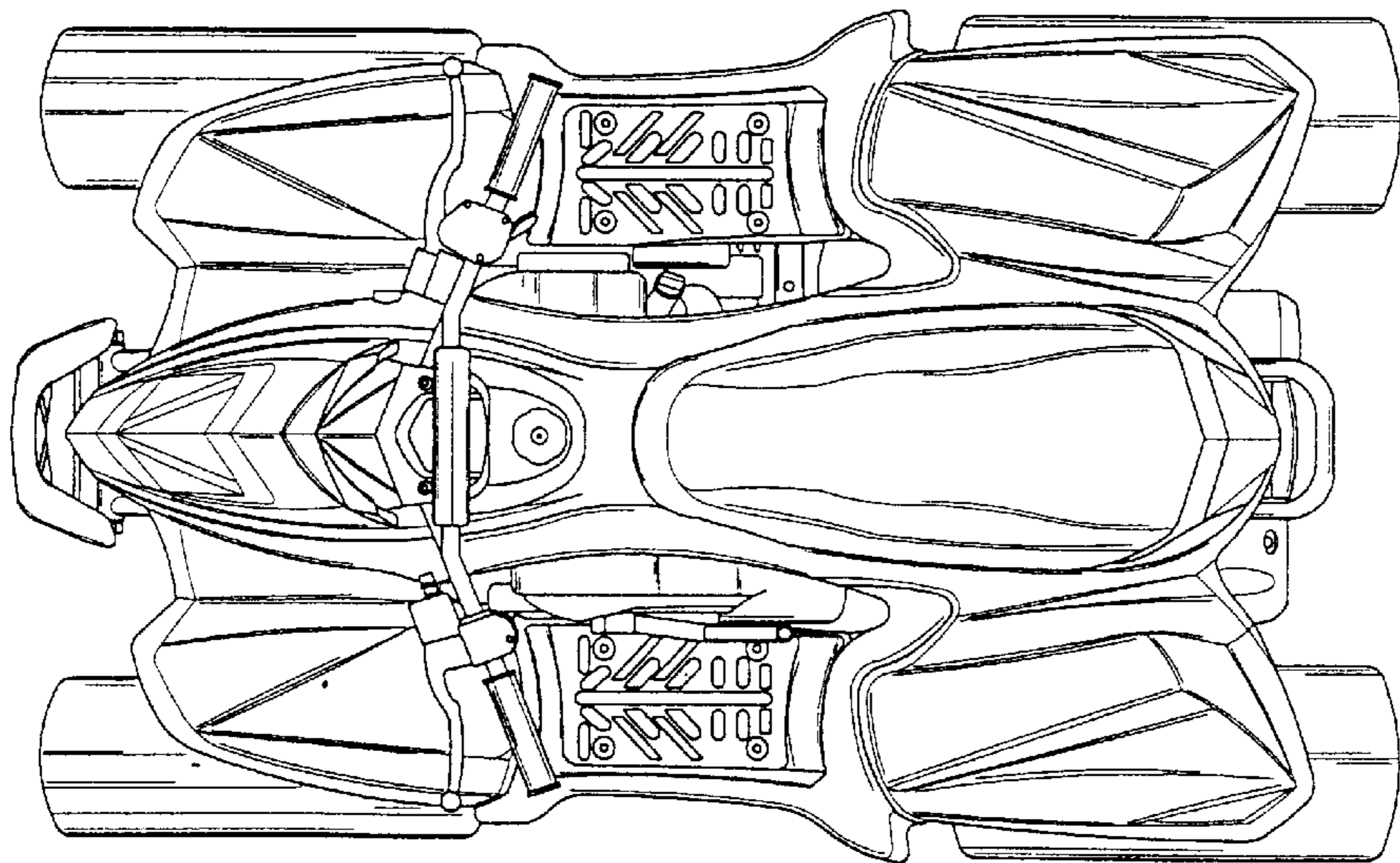

FIG. 7