



US00D484953S

(12) **United States Design Patent**
Renaud

(10) **Patent No.:** **US D484,953 S**
(45) **Date of Patent:** **** Jan. 6, 2004**

(54) **FLEXIBLE TUBE HAVING A VARIABLE STIFFNESS BELLOWS**

- (75) Inventor: **Michel Claude Renaud**, Prangins (CH)
- (73) Assignee: **E. I. duPont de Nemours and Company**, Wilmington, DE (US)
- (**) Term: **14 Years**
- (21) Appl. No.: **29/162,123**
- (22) Filed: **Jun. 10, 2002**

Related U.S. Application Data

- (62) Division of application No. 29/142,253, filed on May 22, 2001, now Pat. No. Des. 460,536, which is a division of application No. 29/125,826, filed on Jun. 30, 2000, now Pat. No. Des. 447,792.
- (51) **LOC (7) Cl.** **23-01**
- (52) **U.S. Cl.** **D23/266**
- (58) **Field of Search** D23/266; 138/118, 138/121, 173, 177

(56) **References Cited**

U.S. PATENT DOCUMENTS

1,547,431	A	*	7/1925	Mallory	138/121
3,050,087	A	*	8/1962	Caplan	138/121
D221,078	S	*	7/1971	Seckel et al.	D23/266
3,842,865	A	*	10/1974	Torricelli	138/121
6,056,018	A	*	5/2000	Renaud	138/121

* cited by examiner

Primary Examiner—Robin V. Taylor

(57) **CLAIM**

The ornamental design for a flexible tube having a variable stiffness bellows, as shown and described.

DESCRIPTION

FIG. 1 is a perspective view of a flexible tube having a stiffness bellows showing my new design;
 FIG. 2 is a front view thereof;
 FIG. 3 is a side elevational view thereof; and,
 FIG. 4 is a sectional view taken along line 4—4 in FIG. 3.

The invention is illustrated in FIG. 1 where there is shown a flexible tube that includes a bellows having a plurality of convolutes formed therein spaced at an interval from each other in the axial direction of flexible tube. The convolutes are raised circumferential ridges formed in the surface of the tube as an integral part thereof, have bending sections that are approximately the same height above the outer surface of the tube and restrained elongation sections that are approximately the same height above the outer surface of the tube with the bending sections having a height above the outer surface of the tube greater than the height of the restrained elongation sections above the outer surface of tube.

In FIG. 2, there is shown another embodiment of the invention which is similar to that shown in FIG. 1, except that the shape of the convolutes has been modified such that near the surface of the tube the convolutes are narrower in the area of the higher restrained elongation sections of the convolutes than in the area of the lower bending sections of the convolutes, with the width of the convolutes being tapered moving from the bending sections to the restrained elongation sections.

Another embodiment of the invention is shown in FIG. 3, where there is shown a flexible tube as in FIG. 1, where the restrained elongation sections include two radially-spaced ridges which are attached at both ends to the bending sections of the convolutes.

FIG. 4 show a flexible tube of the invention similar to that of FIGS. 3 except that the ridges formed in the convolute are tapered.

1 Claim, 1 Drawing Sheet

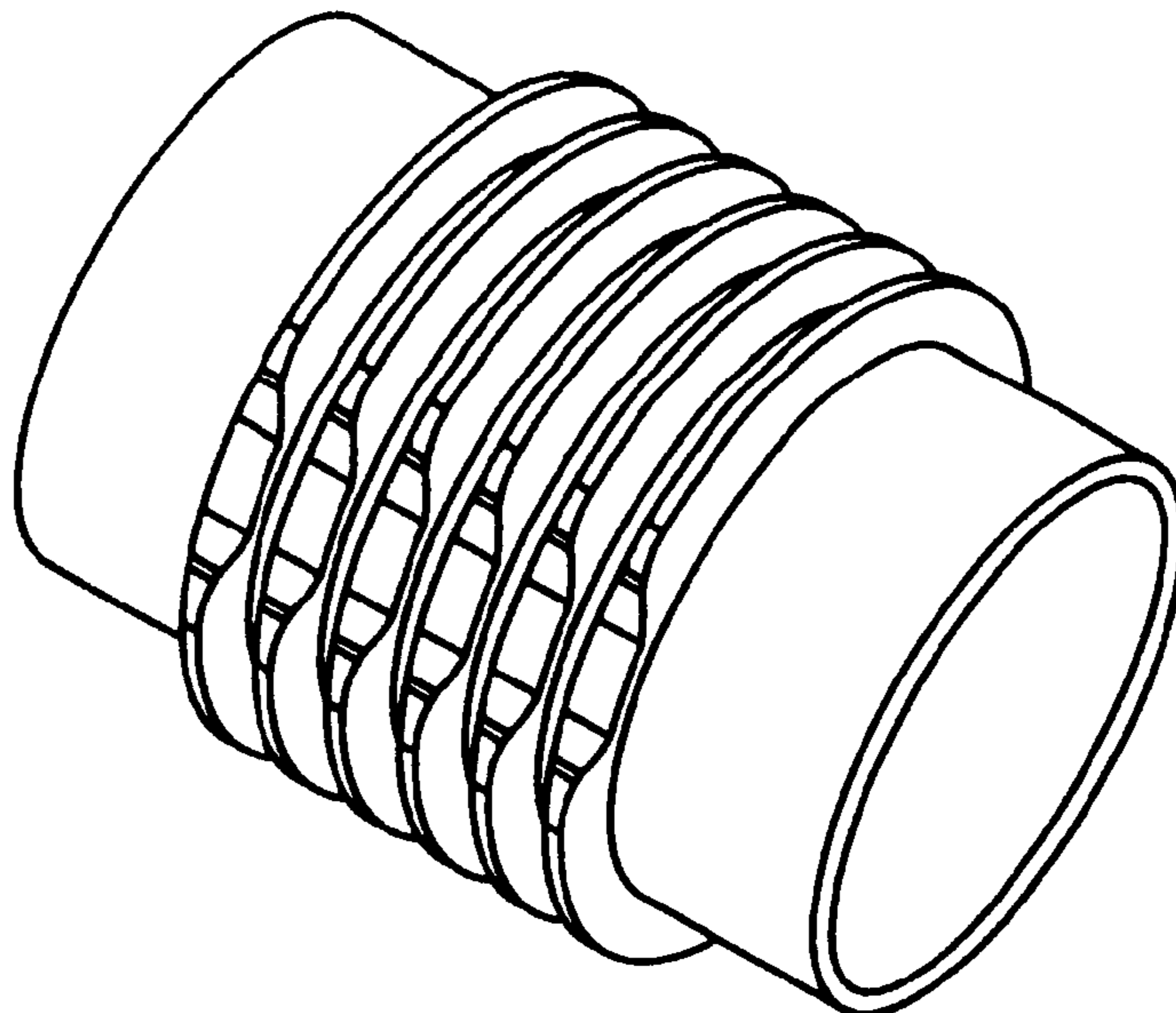

FIG. 1

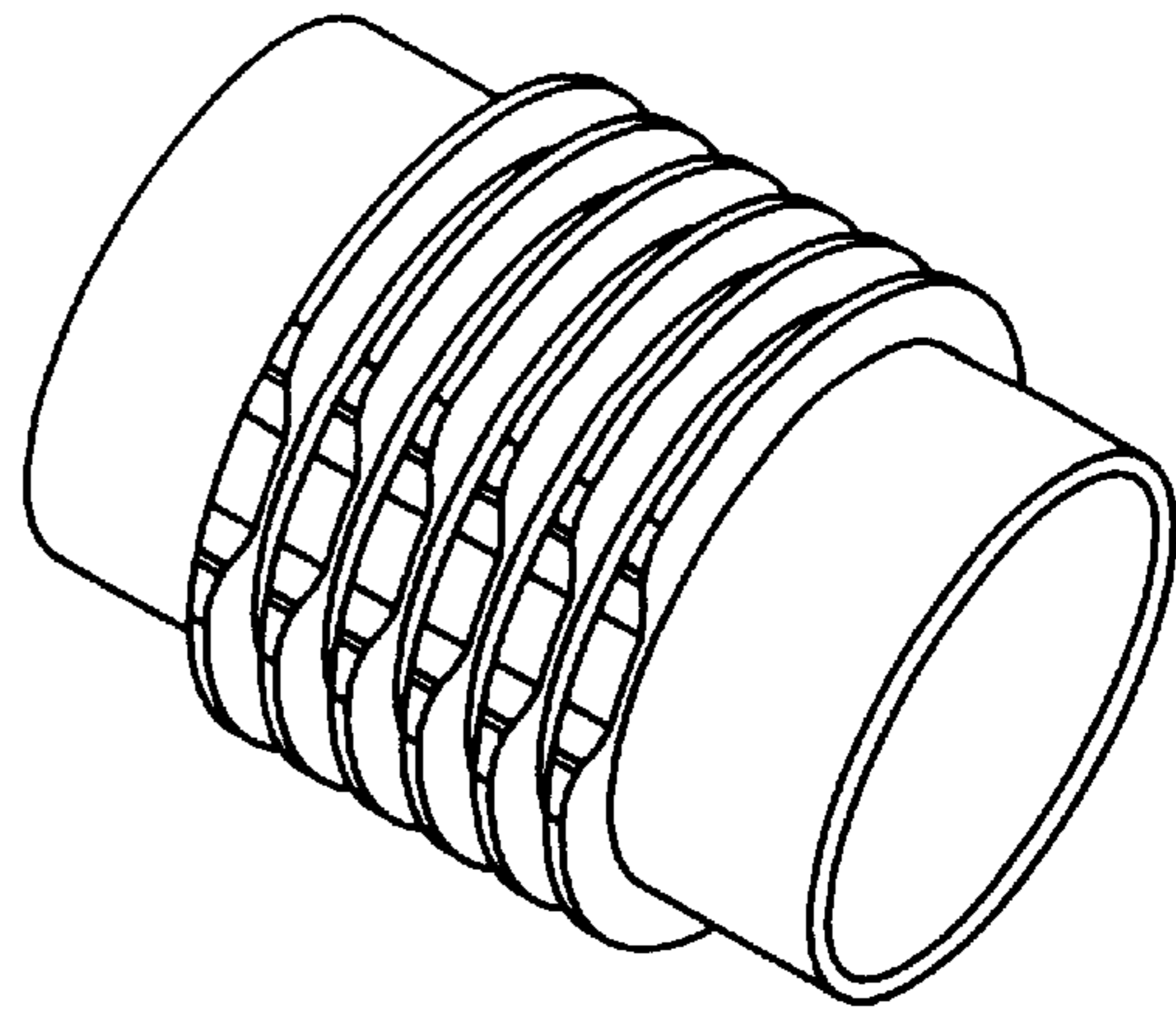

FIG. 2

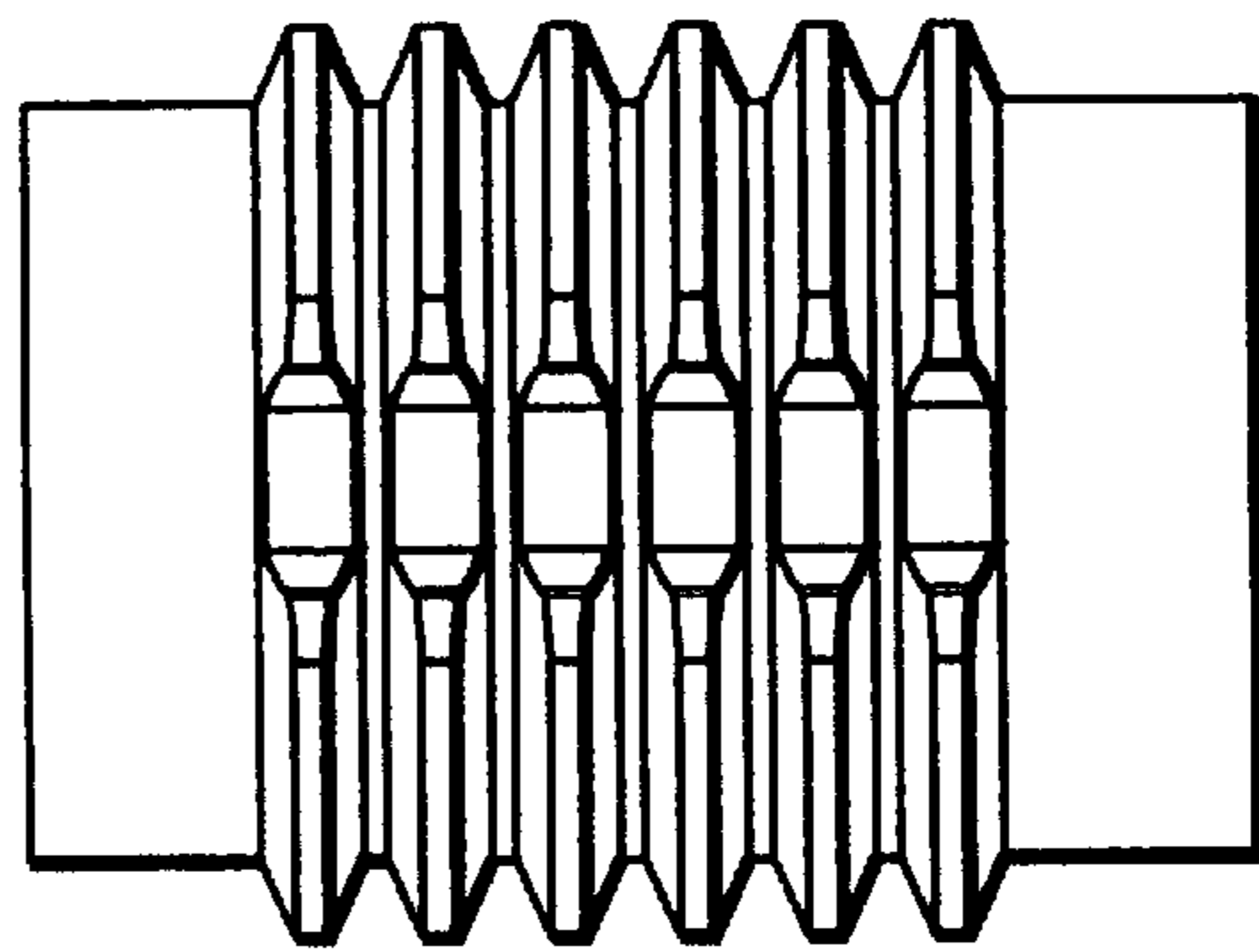

FIG. 3

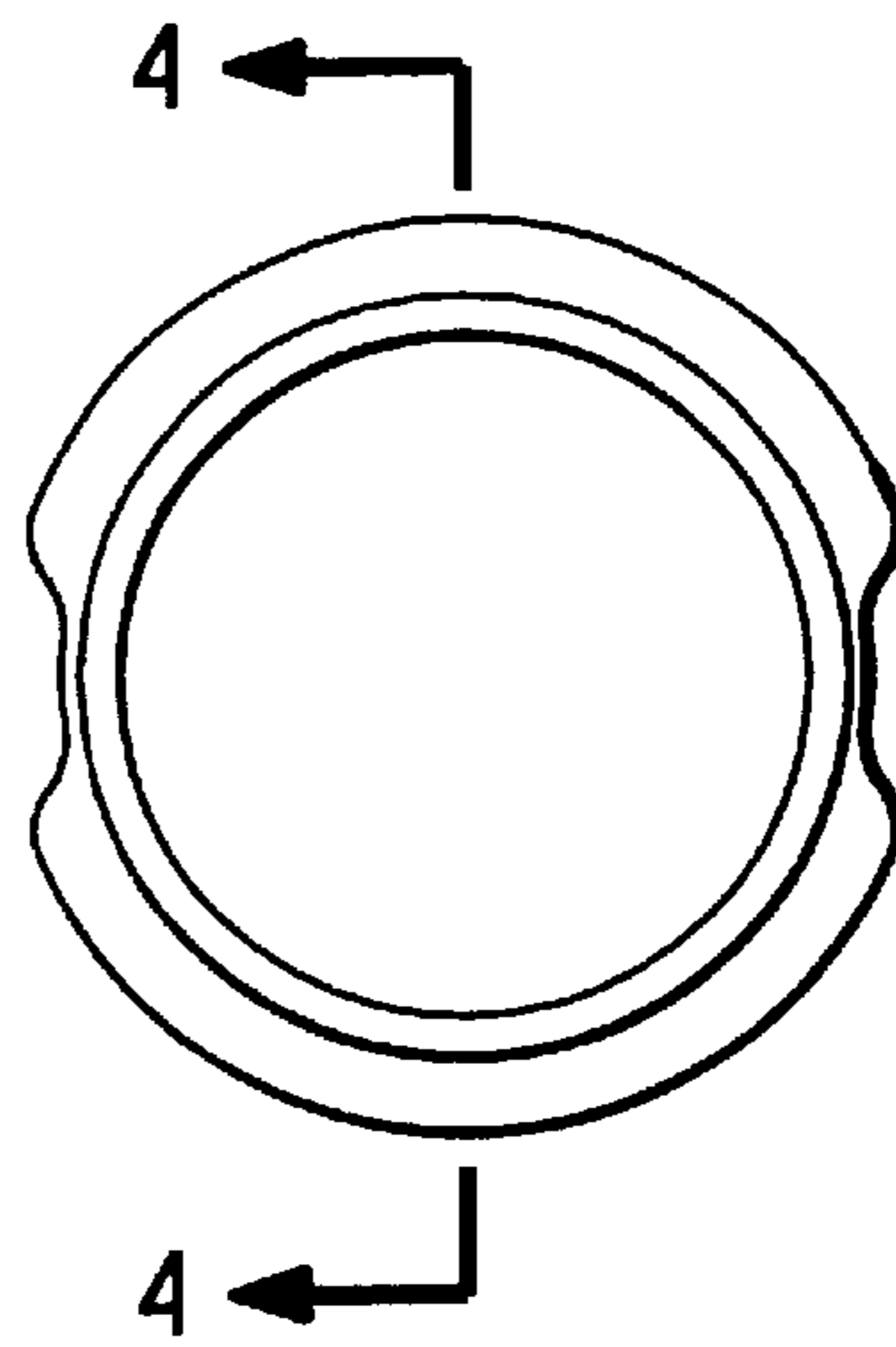

FIG. 4

