



US00D484920S

(12) **United States Design Patent**  
**Stewart**

(10) **Patent No.: US D484,920 S**

(45) **Date of Patent: \*\* \*Jan. 6, 2004**

(54) **COMBINED GAME BOARD AND BLOCKS**

**DESCRIPTION**

(76) Inventor: **David Stewart**, 3570 Avondale Dr., Salt Lake City, UT (US) 84121

(\* ) Notice: This patent is subject to a terminal disclaimer.

(\*\*) Term: **14 Years**

(21) Appl. No.: **29/172,006**

(22) Filed: **Dec. 3, 2002**

(51) **LOC (7) Cl.** ..... **21-01**

(52) **U.S. Cl.** ..... **D21/341; D21/365**

(58) **Field of Search** ..... **D21/334-368, D21/369, 372; 273/236-288**

(56) **References Cited**

**U.S. PATENT DOCUMENTS**

D122,566	S	*	9/1940	Cabral	.....	D21/365
3,672,679	A	*	6/1972	Burns	.....	273/260
D224,772	S	*	9/1972	Hurley	.....	D21/372
3,779,554	A	*	12/1973	Brix	.....	273/260
D270,170	S	*	8/1983	Shoptaugh	.....	D21/342
4,776,597	A	*	10/1988	Rudell	.....	273/241
5,462,281	A	*	10/1995	Gaito et al.	.....	273/238
D421,776	S	*	3/2000	Borg	.....	D21/336

\* cited by examiner

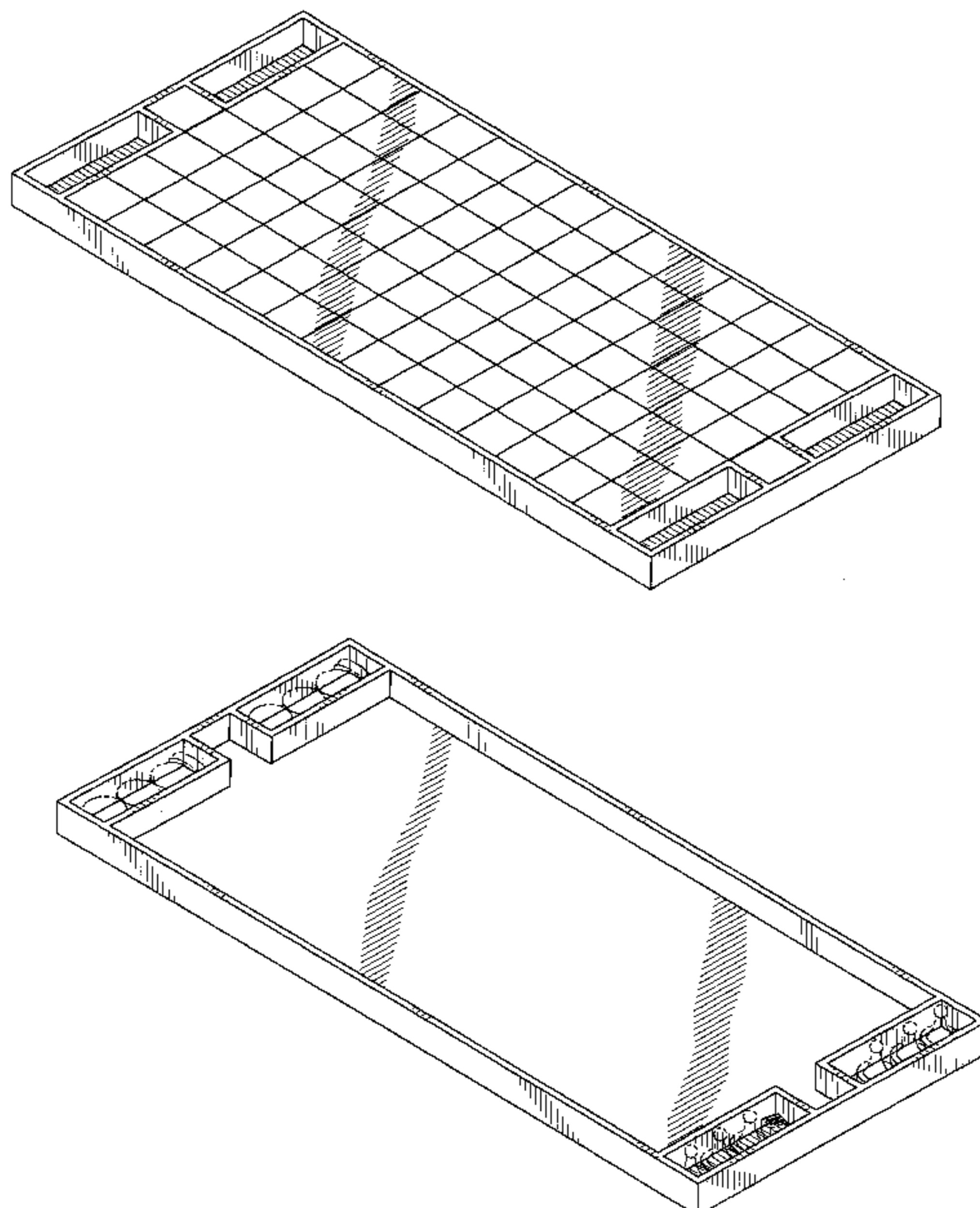
*Primary Examiner*—Sandra L. Morris  
(74) *Attorney, Agent, or Firm*—TraskBritt

(57) **CLAIM**

The ornamental design for a combined game board and blocks, as shown and described.

FIG. 1 is a perspective view of a combined game board and blocks showing my new design;  
 FIG. 2 is a top elevational view of my design;  
 FIG. 3 is a bottom elevational view thereof;  
 FIG. 4 is a side elevational view thereof, with the opposite side being a mirror image;  
 FIG. 5 is a front plan view thereof, with the opposite rear view being a mirror image;  
 FIG. 6 is a front perspective view of the game board, the broken lines showing a perspective view of a carrying case of the game board, and forming no part of the claimed design;  
 FIG. 7 is the perspective view of the game board with the addition of holes in end blocks, the broken lines showing games pieces of the game board, and forming no part of the claimed design;  
 FIG. 8 is a front perspective view of the second depicted embodiment of the game board showing my new design, the broken lines showing blocks of the game board;  
 FIG. 9 is a top elevational view of the second depicted embodiment thereof;  
 FIG. 10 is a bottom elevational view of the second depicted embodiment thereof;  
 FIG. 11 is a side elevational view of the second depicted embodiment thereof, with the opposite side being a mirror image;  
 FIG. 12 is a front plan view of the second depicted embodiment thereof, with the opposite rear view being a mirror image;  
 FIG. 13 is a perspective view of the second depicted embodiment of the game board without the blocks, the broken lines showing a perspective view of a carrying case of the game board, and forming no part of the claimed design; and,  
 FIG. 14 is a perspective view of the second depicted embodiment of the game board, the broken lines showing games pieces of the game board, and forming no part of the claimed design.

**1 Claim, 10 Drawing Sheets**



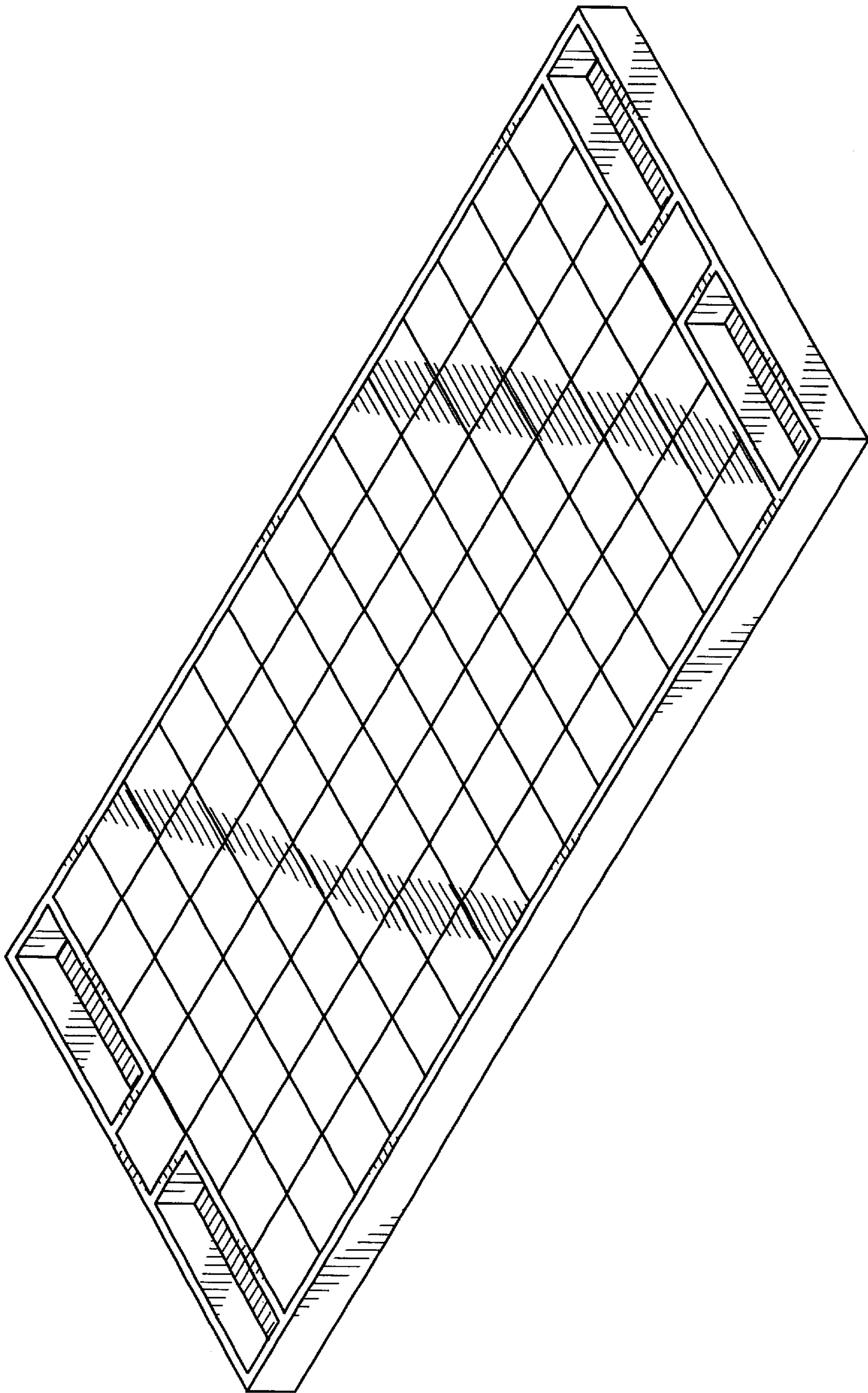
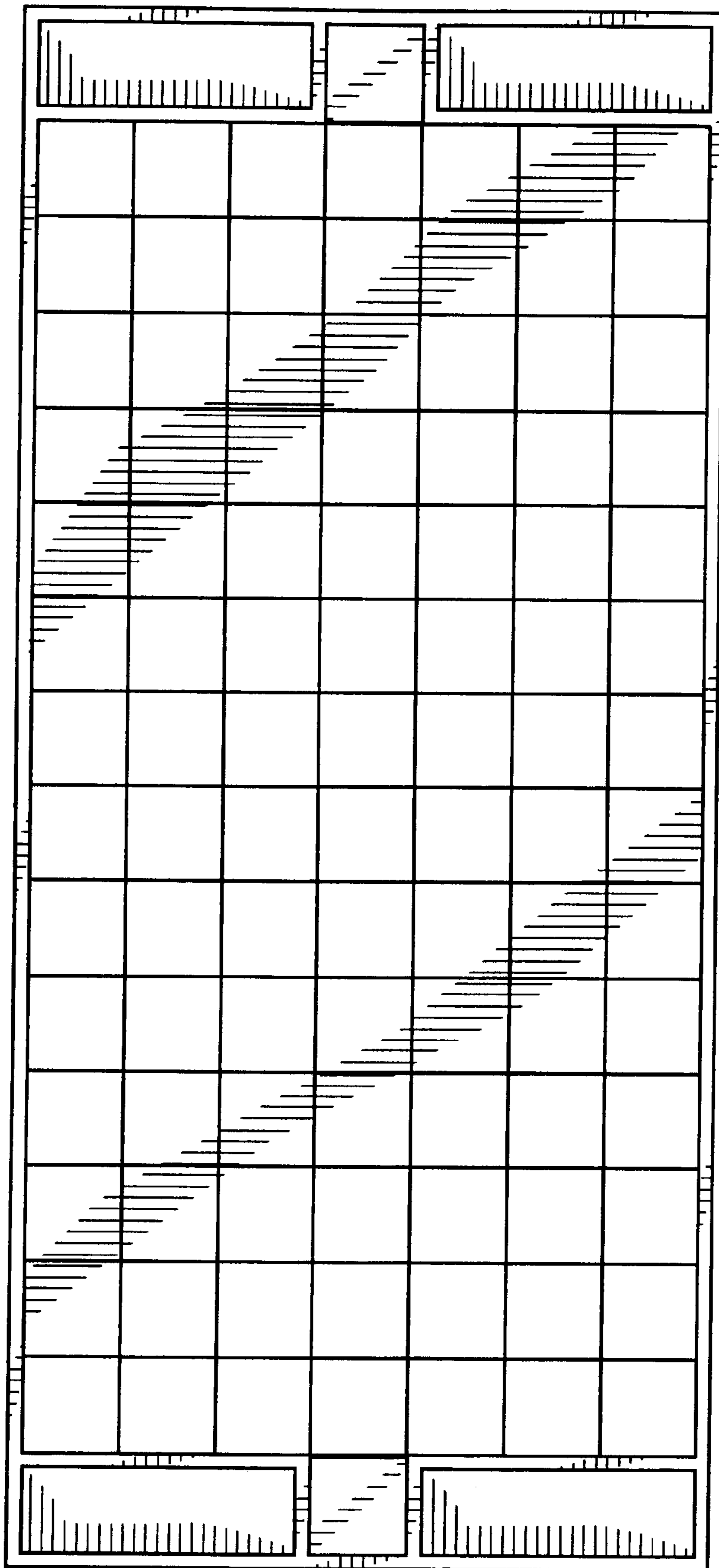
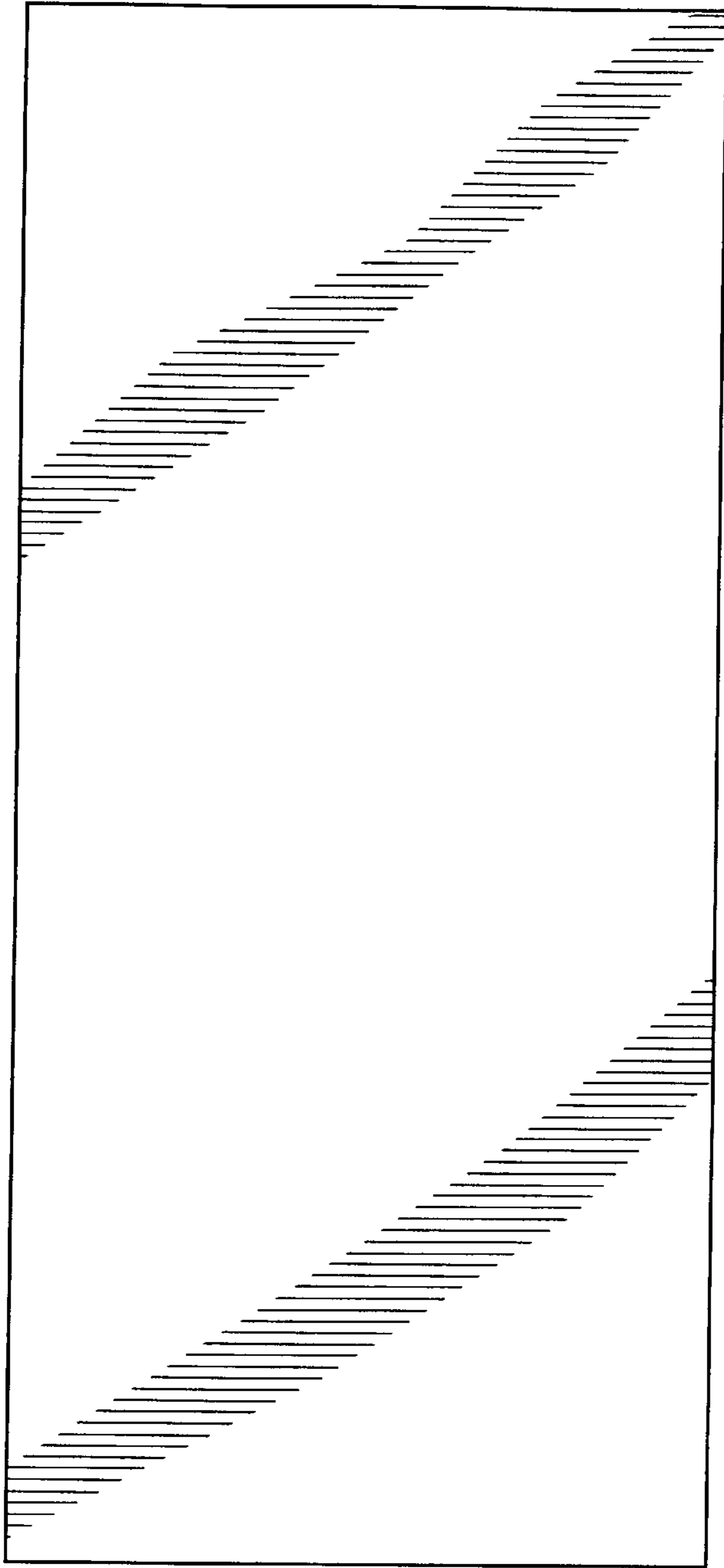


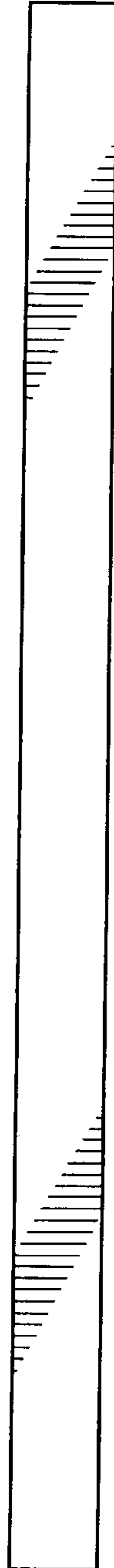
FIG. 1



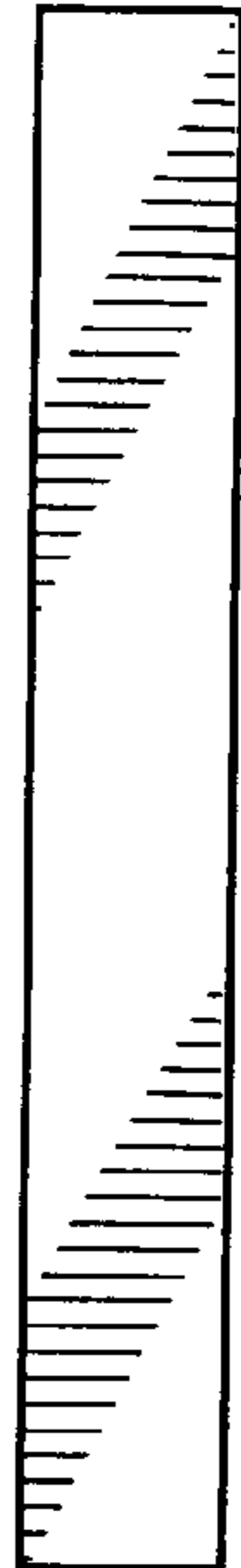
**FIG. 2**



**FIG. 3**



**FIG. 4**



**FIG. 5**



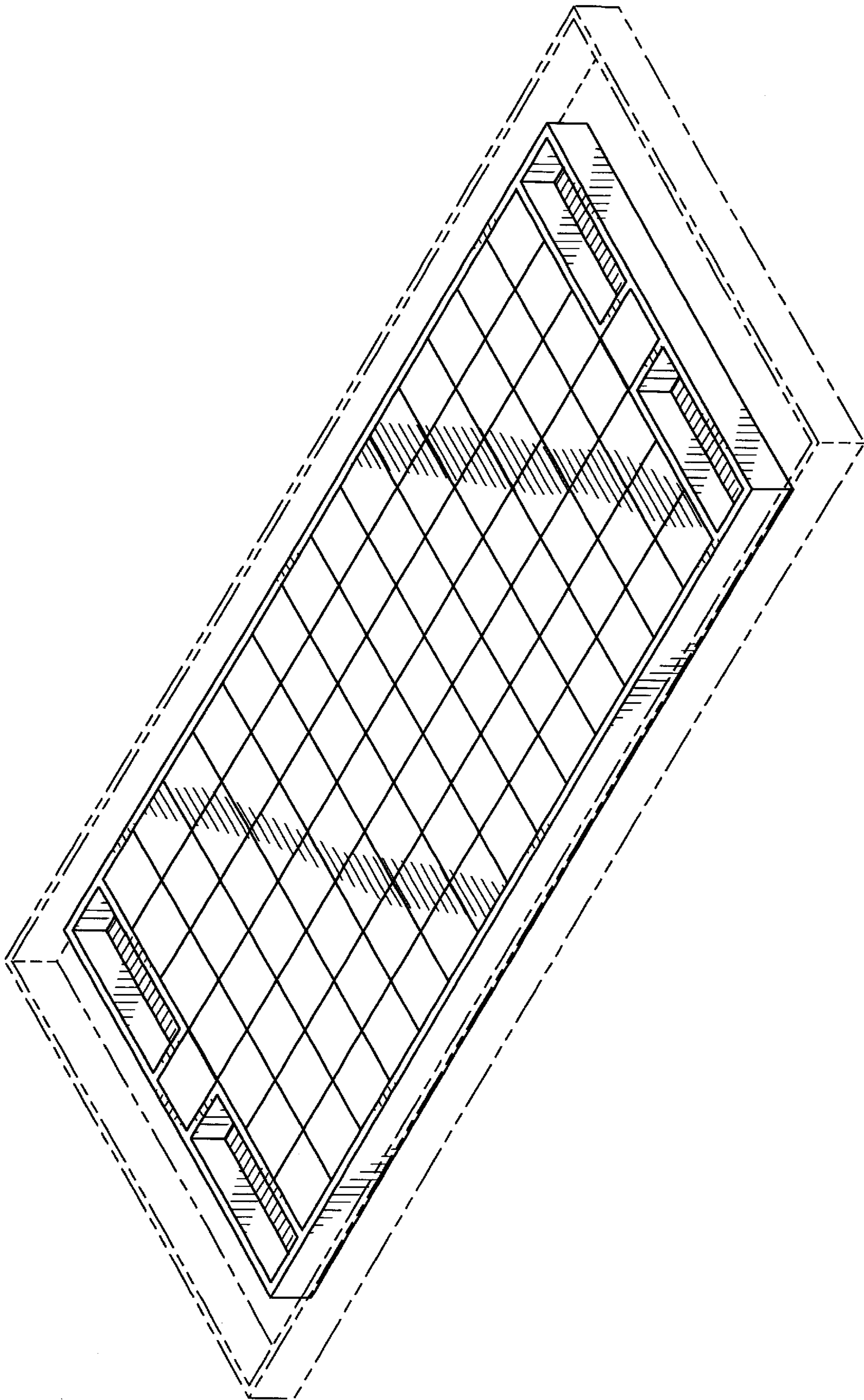


FIG. 6

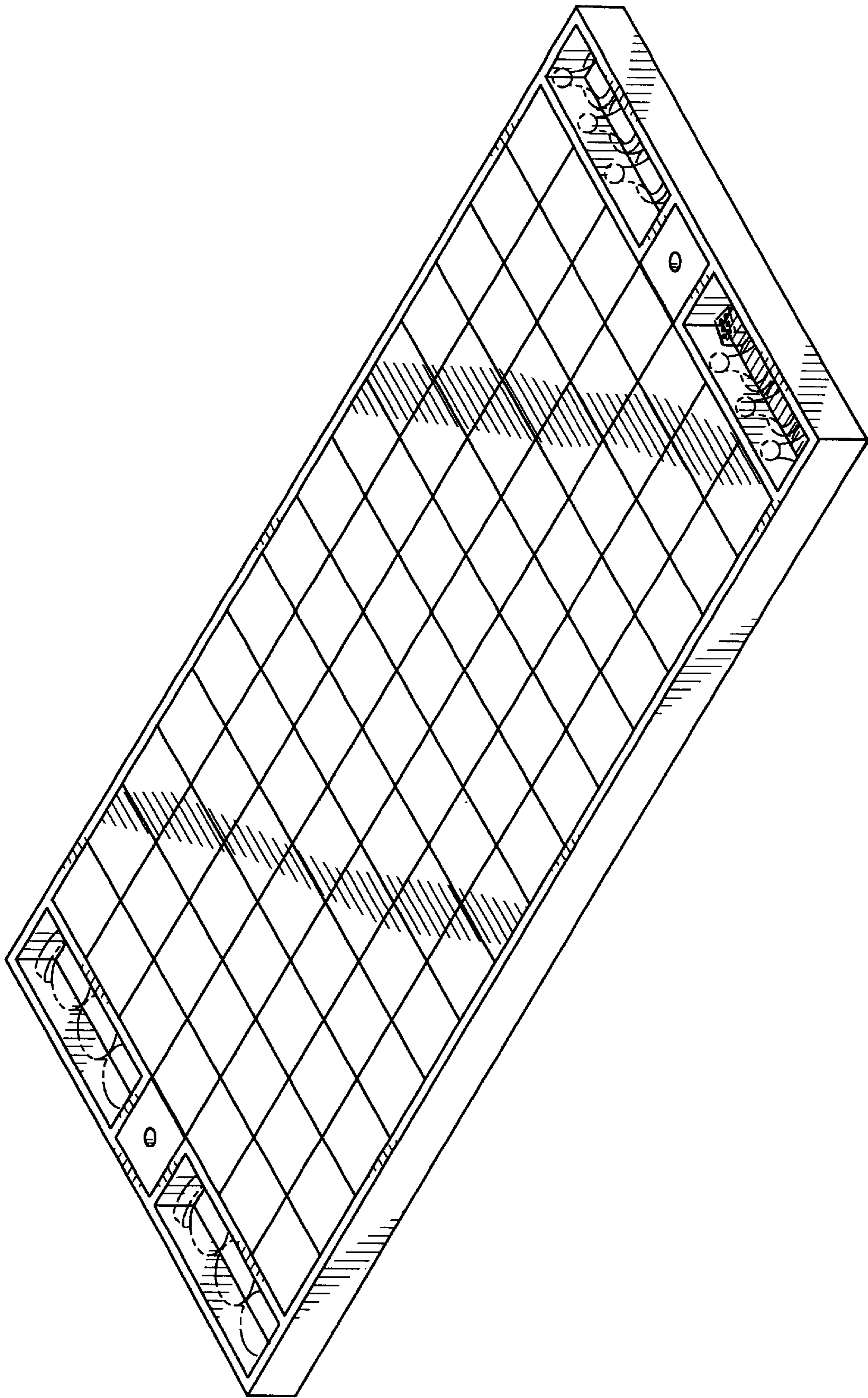
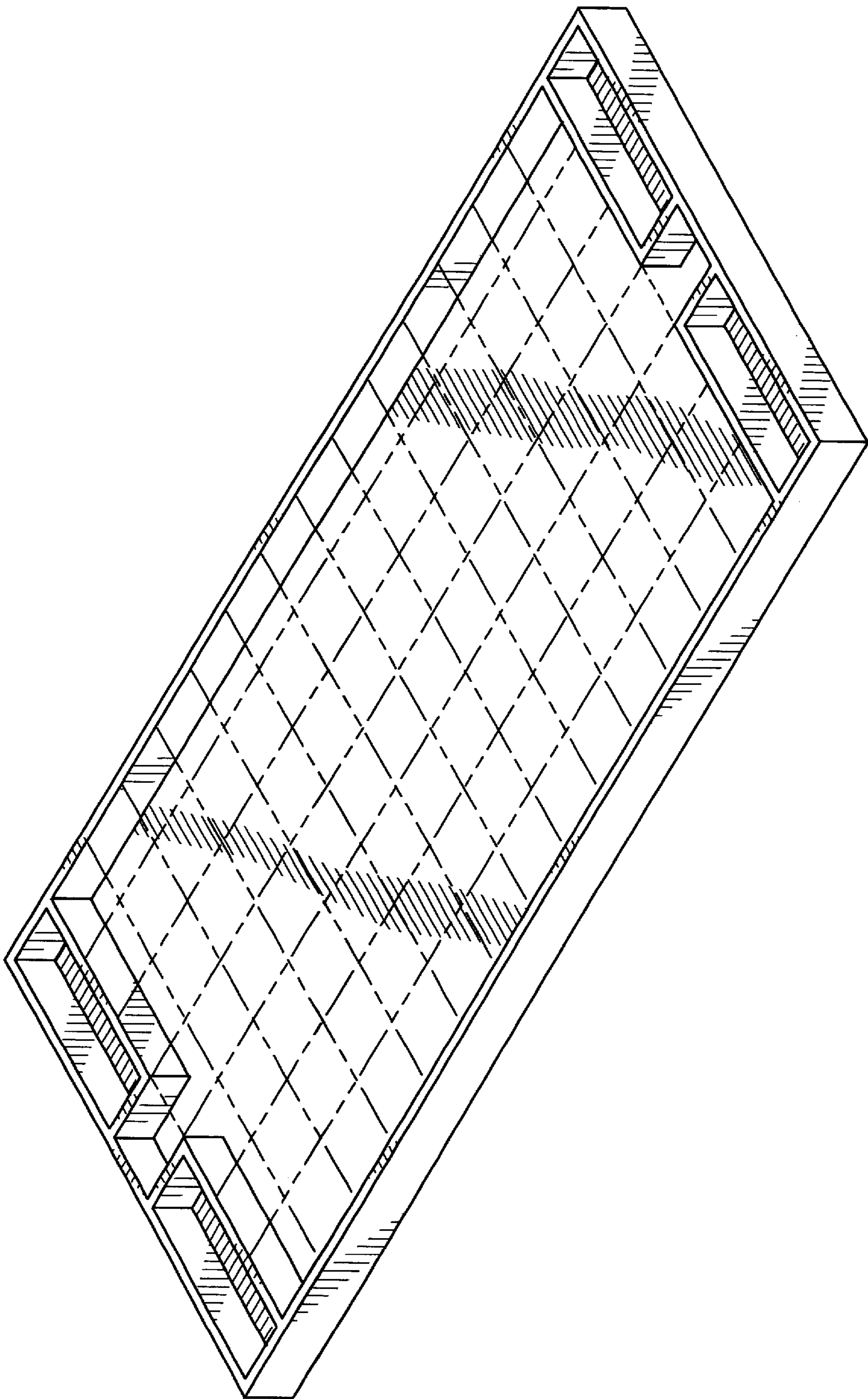
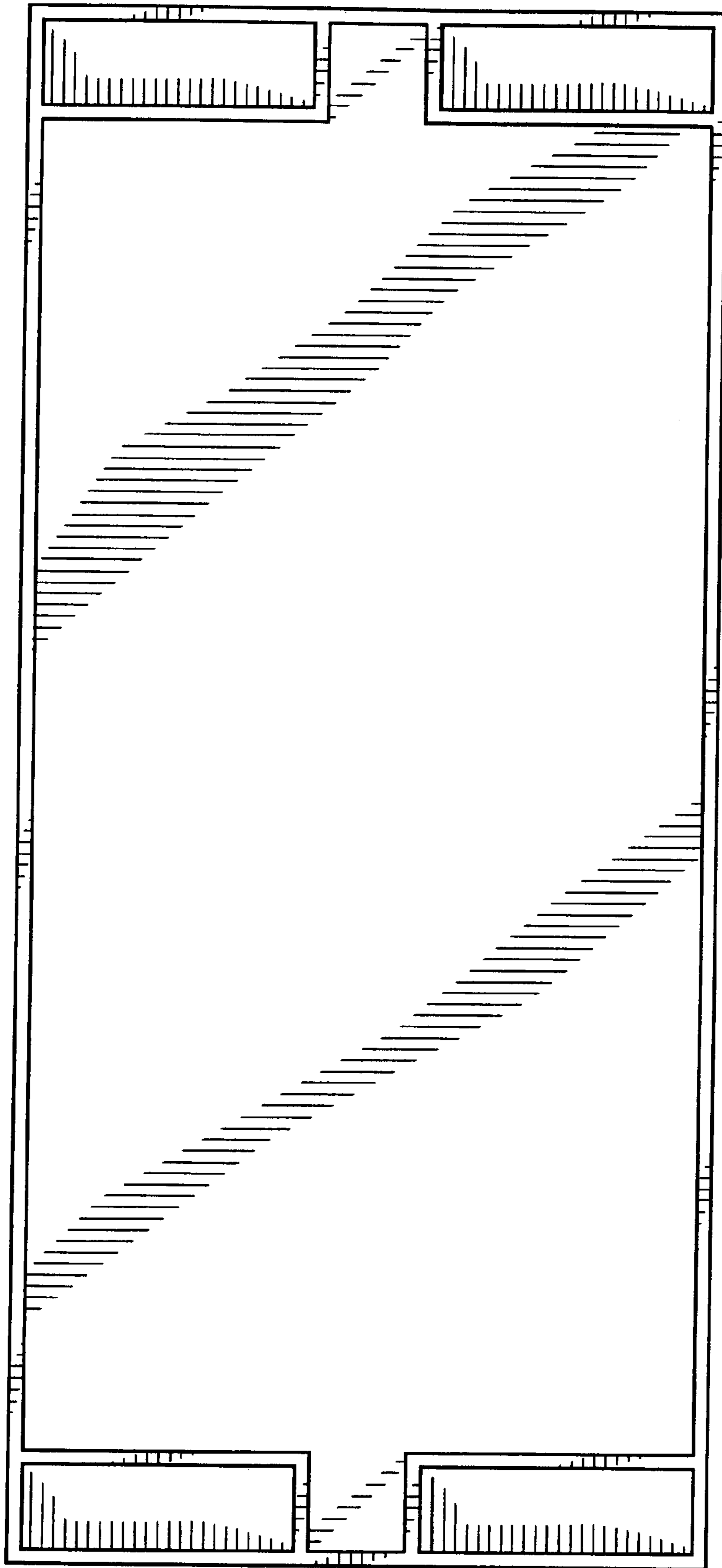


FIG. 7



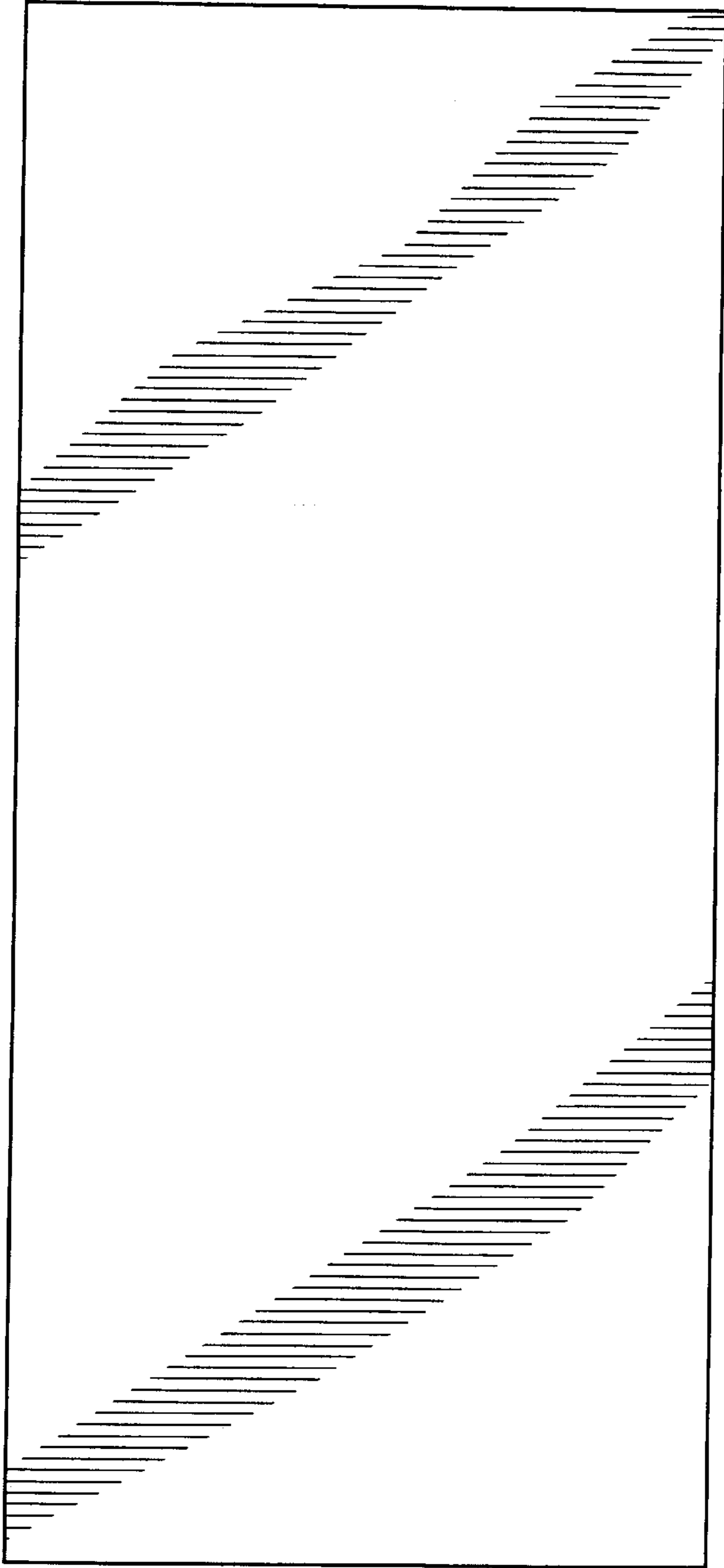
**FIG. 8**



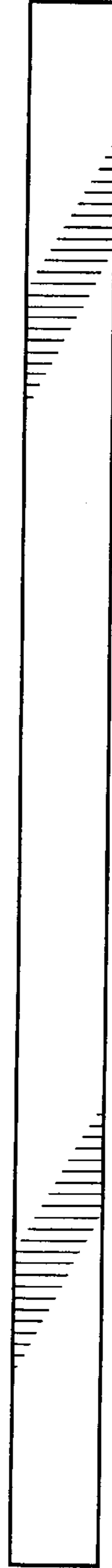


**FIG. 9**

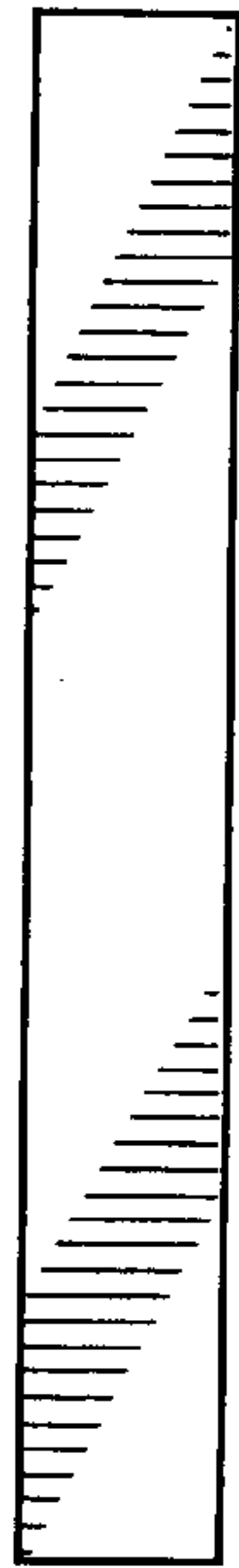




**FIG. 10**



**FIG. 11**



**FIG. 12**

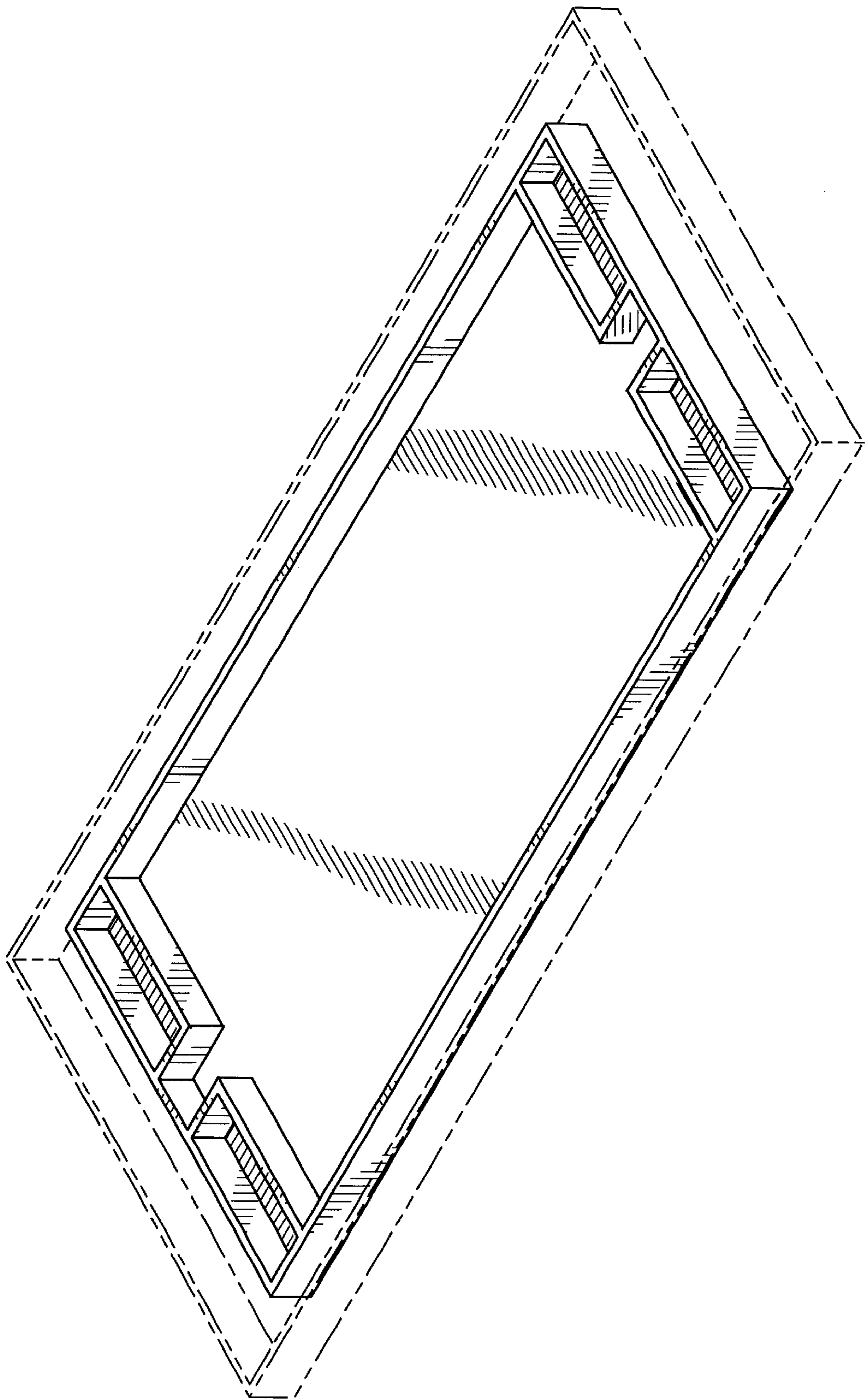
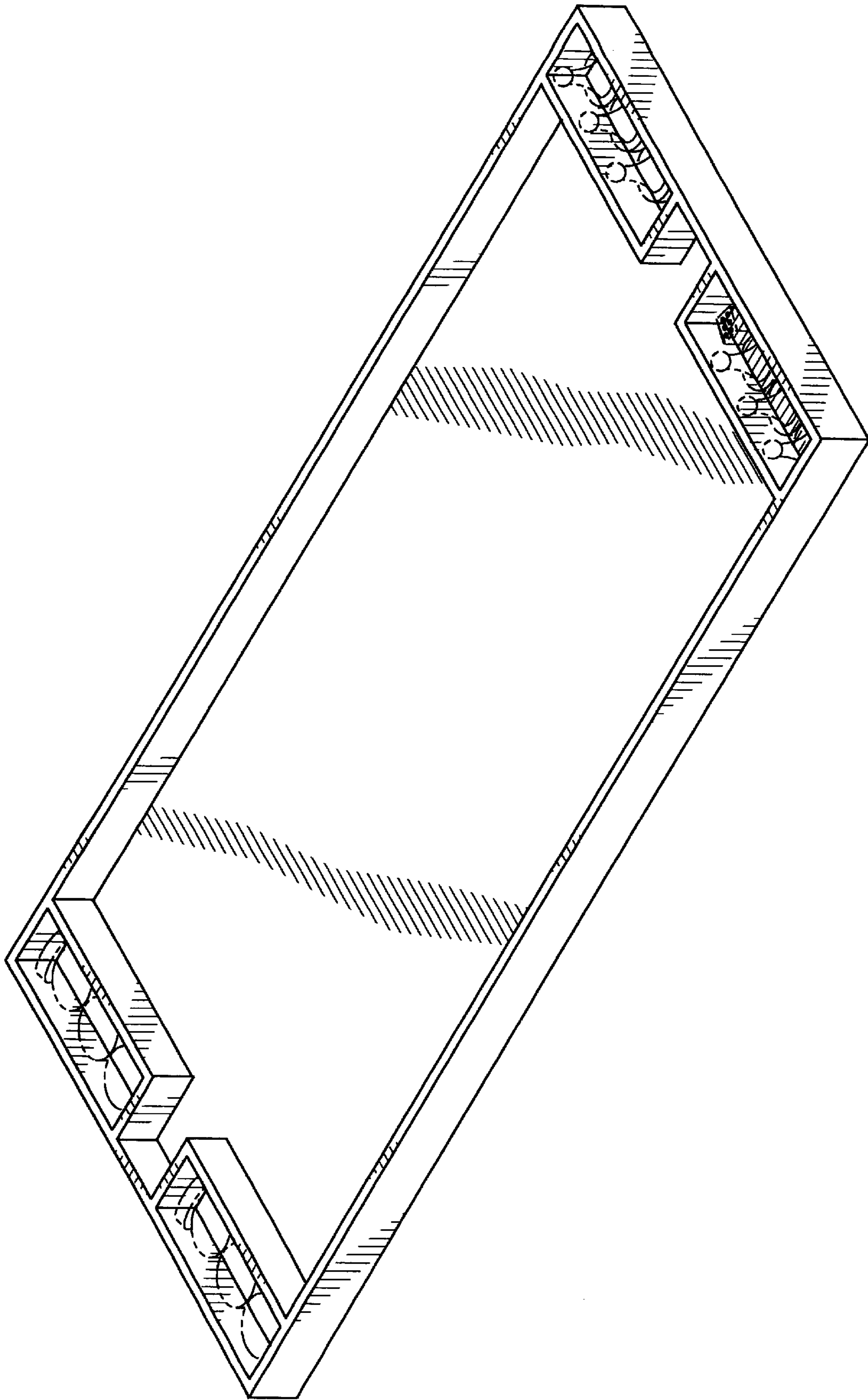


FIG. 13



**FIG. 14**