



US00D484772S

(12) **United States Design Patent**
Wiesenthal

(10) **Patent No.:** **US D484,772 S**

(45) **Date of Patent:** **** *Jan. 6, 2004**

(54) **MOTORCYCLE HANDGRIP AND FOOTPEG**

(75) Inventor: **Thomas J. Wiesenthal**, Waukesha, WI (US)

(73) Assignee: **Advanced Cycle Designs, Inc.**, Waukesha, WI (US)

(*) Notice: This patent is subject to a terminal disclaimer.

(**) Term: **14 Years**

(21) Appl. No.: **29/163,139**

(22) Filed: **Jun. 27, 2002**

(51) **LOC (7) Cl.** **08-06**

(52) **U.S. Cl.** **D8/303**; D12/114

(58) **Field of Search** D12/110, 114, D12/122-124, 174, 177, 178, 179, 180; D8/303; 74/551.1-551.9, 564, 594.4; 180/219; 280/288.1-288.4, 281.1, 291, 293; 296/75; 16/421, DIG. 12

(56) **References Cited**

U.S. PATENT DOCUMENTS

D447,456 S 9/2001 Larson et al.

OTHER PUBLICATIONS

Custom Chrome 1998 catalog, footpegs and grip set at top of p. 4.23.*

* cited by examiner

Primary Examiner—Pamela Burgess

Assistant Examiner—Linda Brooks

(74) *Attorney, Agent, or Firm*—Andrus, Scales, Starke & Sawall, LLP

(57) **CLAIM**

The ornamental design for a motorcycle handgrip and footpeg, as shown and described.

DESCRIPTION

FIG. 1 is a perspective view of my new design shown in position of use as a motorcycle handgrip, with the remainder of the motorcycle shown in broken lines for illustrative purposes;

FIG. 2 is an enlarged perspective view of the motorcycle handgrip shown in FIG. 1 and the motorcycle footpeg shown in FIG. 7;

FIG. 3 is an elevational view of the motorcycle handgrip shown in FIG. 2 and an enlarged motorcycle footpeg shown in FIG. 7;

FIG. 4 is a top view of the motorcycle handgrip shown in FIG. 2 and an enlarged motorcycle footpeg shown in FIG. 7;

FIG. 5 is a view of the motorcycle handgrip and footpeg taken from the left side of FIG. 3;

FIG. 6 is a view of the motorcycle handgrip and footpeg taken from the right side of FIG. 3; and,

FIG. 7 is a perspective view of my new design shown in position of use as a motorcycle footpeg, with the remainder of the motorcycle shown in broken lines for illustrative purposes.

The broken lines shown in FIGS. 1 and 7, except for a single handgrip and a footpeg, form no part of the claimed design.

1 Claim, 4 Drawing Sheets

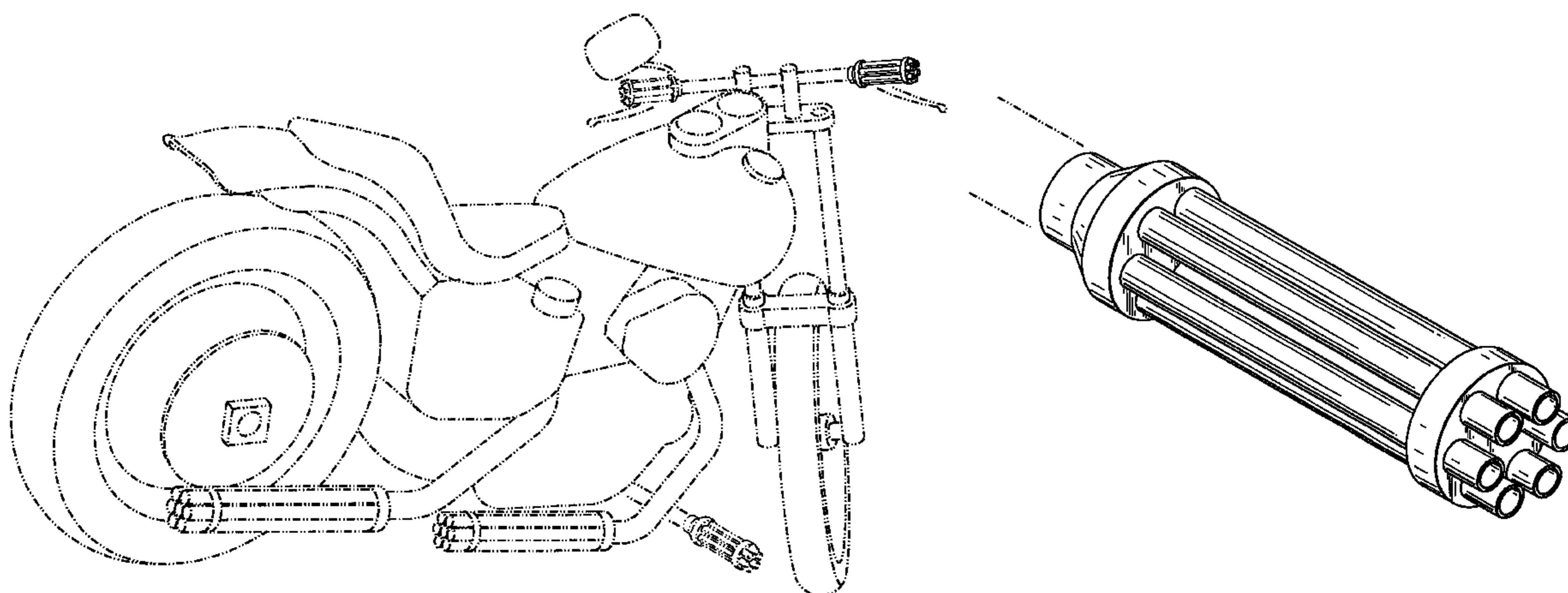

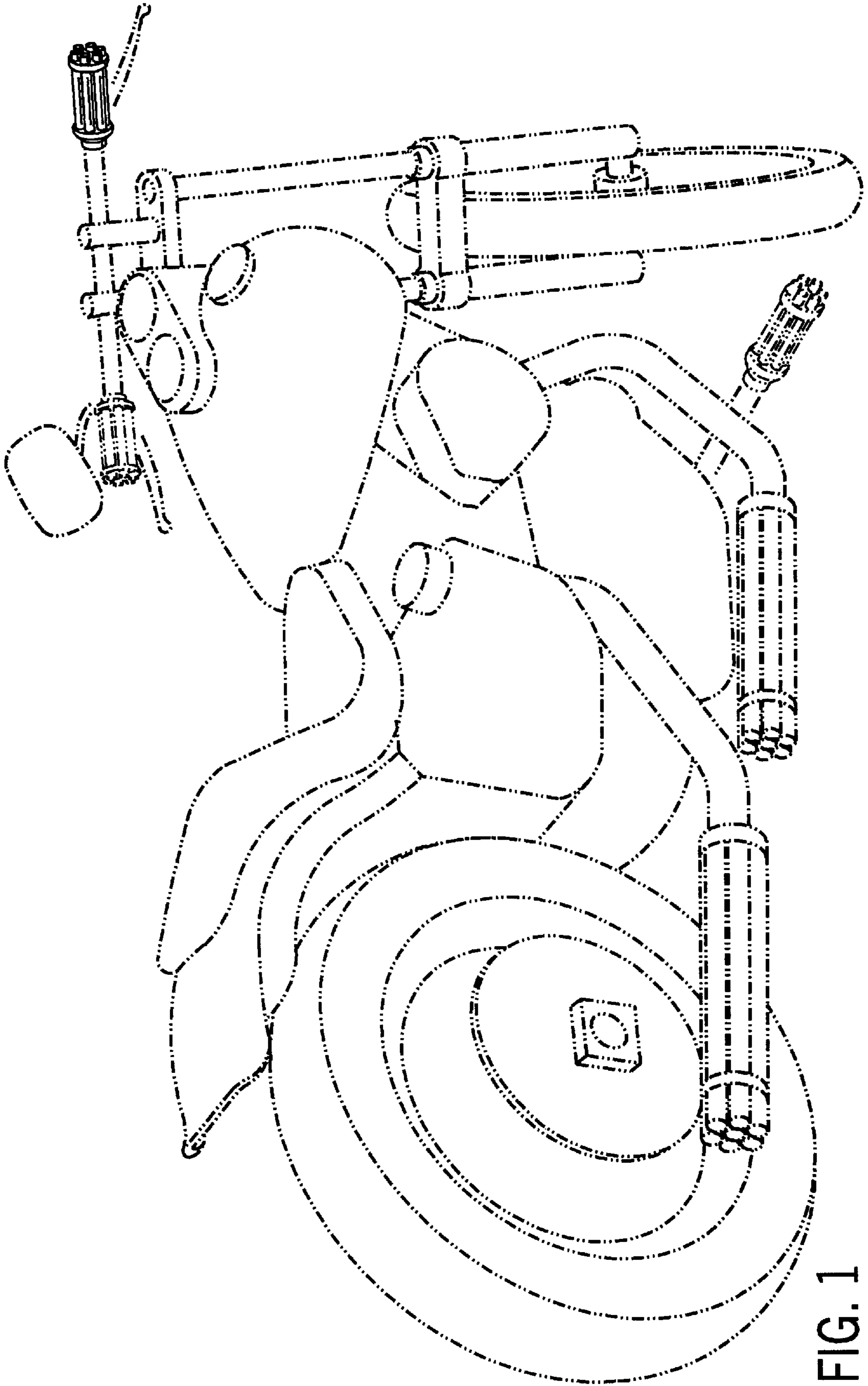

FIG. 1

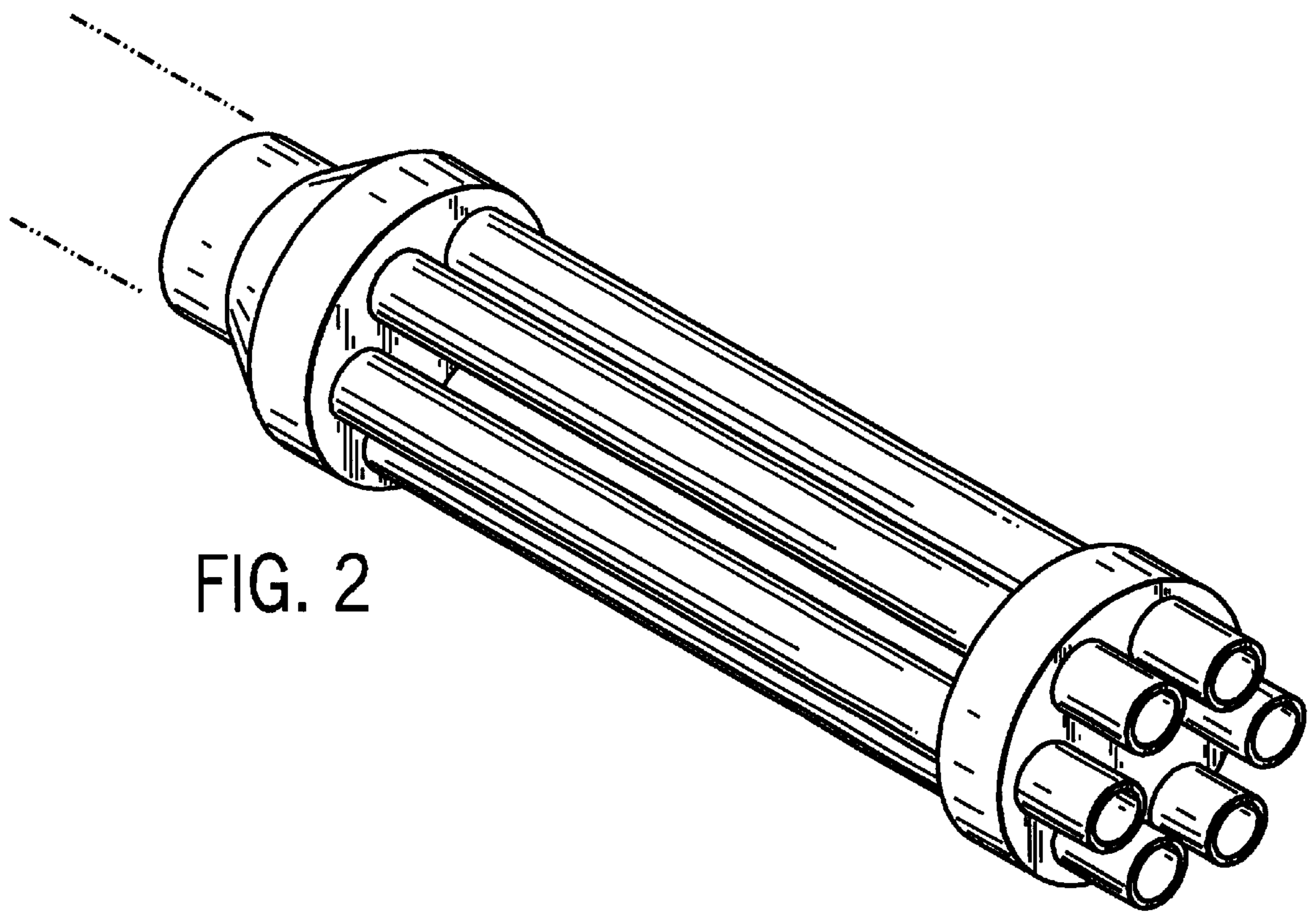

FIG. 2

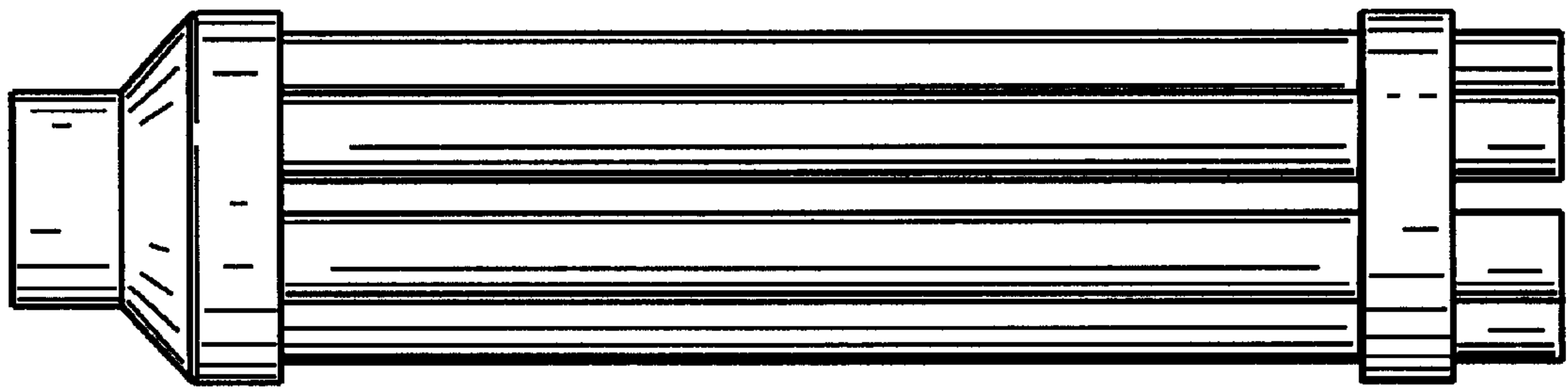

FIG. 3

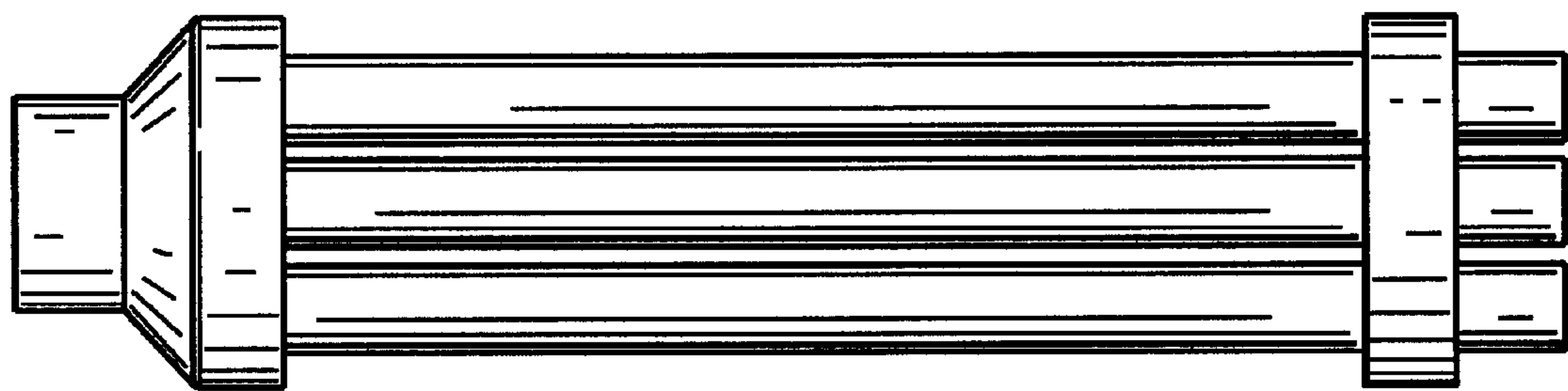

FIG. 4

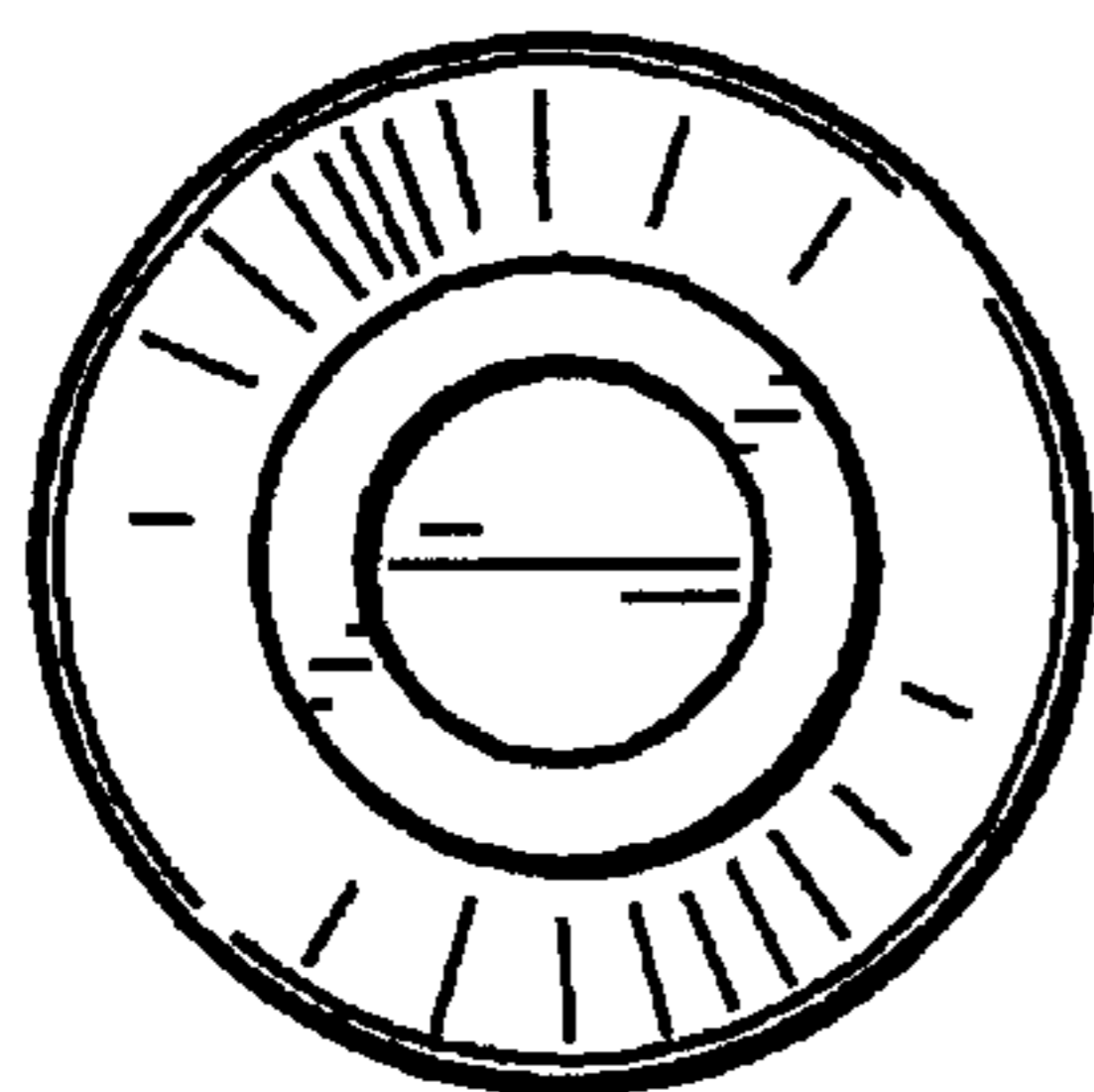

FIG. 5

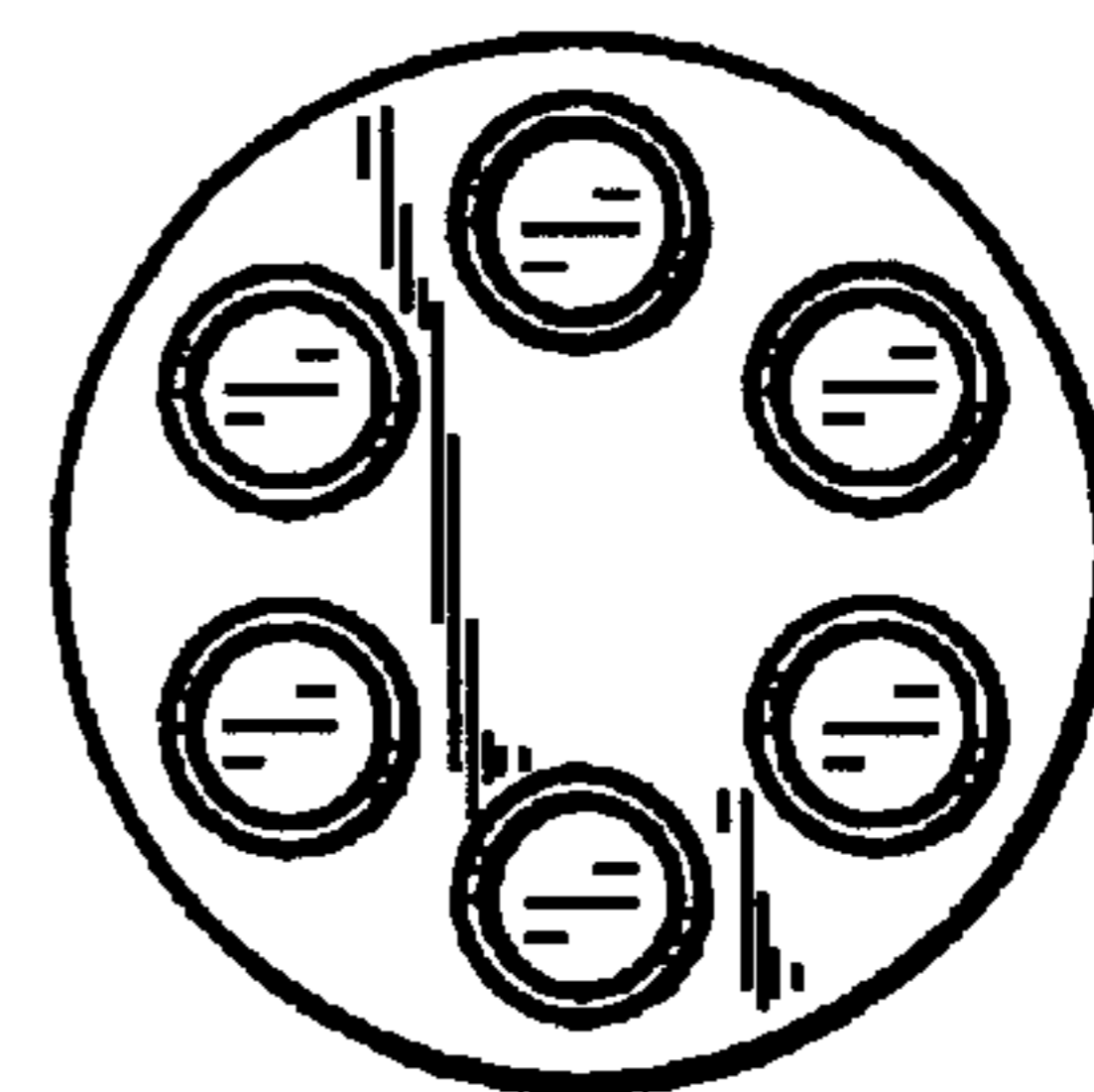

FIG. 6

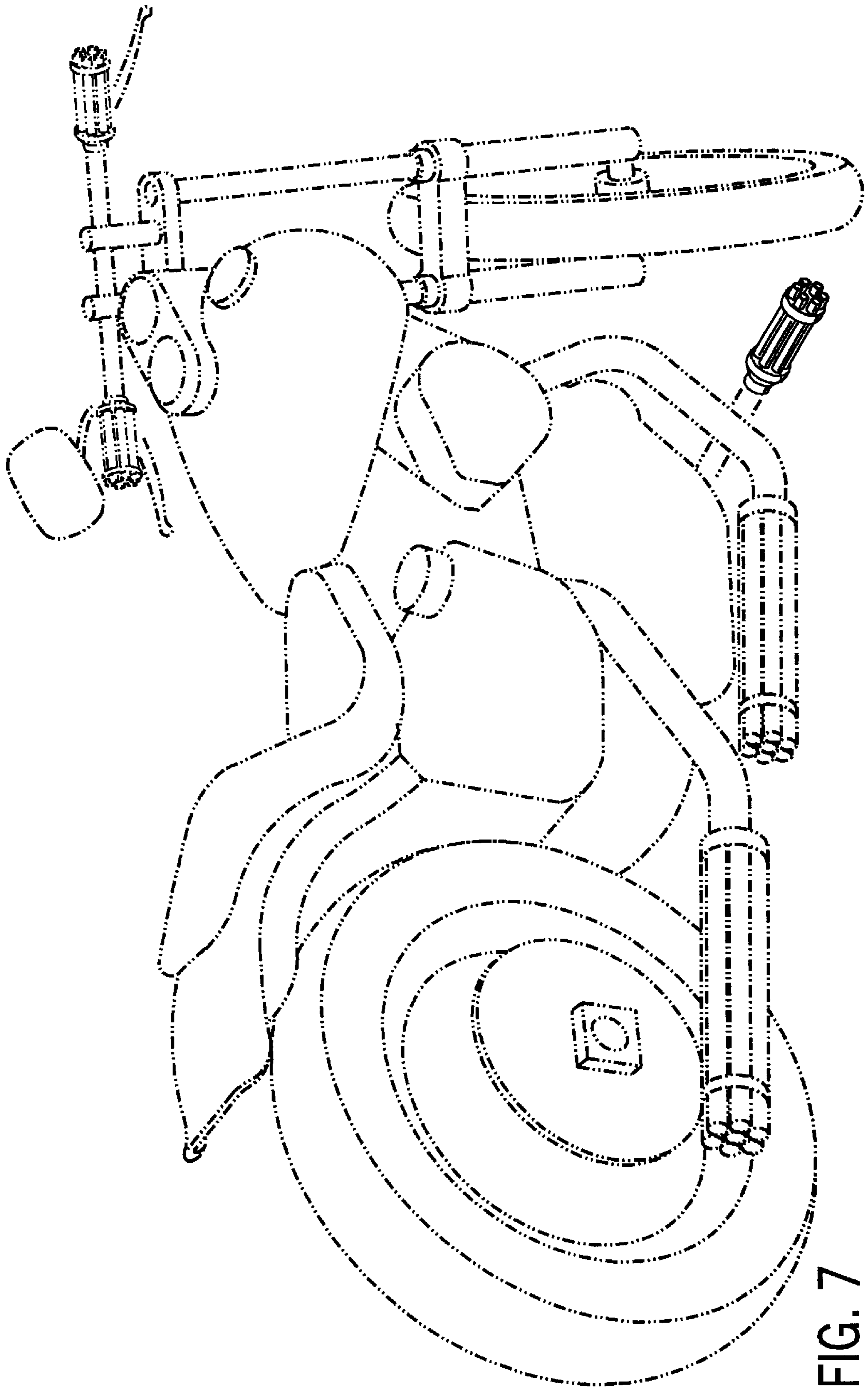

FIG. 7