



US00D484546S

(12) **United States Design Patent**
Horchler

(10) **Patent No.:** **US D484,546 S**

(45) **Date of Patent:** **** Dec. 30, 2003**

(54) **ELECTRONICS PACKAGE**

(75) Inventor: **Jack Horchler**, Mokena, IL (US)

(73) Assignee: **Tek Nek Toys International, Inc.**,
Mokena, IL (US)

(**) Term: **14 Years**

(21) Appl. No.: **29/174,053**

(22) Filed: **Jan. 10, 2003**

(51) **LOC (7) Cl.** **21-01**

(52) **U.S. Cl.** **D21/329; D21/324**

(58) **Field of Search** **D21/324, 329,**
D21/330, 333, 320, 331; 273/148 B, 148 R,
460, 461, 287; 463/6, 30-35, 46, 47, 58;
345/156, 716, 903, 978

(56) **References Cited**

U.S. PATENT DOCUMENTS

D270,460 S	*	9/1983	Burtoff et al.	D21/329
4,512,567 A	*	4/1985	Phillips	273/148 B
5,203,563 A	*	4/1993	Loper, III	273/148 B
5,317,336 A	*	5/1994	Hall	273/148 B
D399,884 S	*	10/1998	Schultz et al.	D21/329
5,829,745 A	*	11/1998	Houle	273/148 B
D410,970 S	*	6/1999	Larian	D21/329
6,092,705 A	*	7/2000	Meritt	273/148 B
D432,585 S	*	10/2000	Okabe	D21/329

D433,075 S	*	10/2000	Larian	D21/329
D435,603 S	*	12/2000	Holmes et al.	D21/329
6,461,238 B1	*	10/2002	Rehkemper et al.	463/30

* cited by examiner

Primary Examiner—Prabhakar Deshmukh

(74) *Attorney, Agent, or Firm*—Michael, Best & Friedrich
LLC

(57) **CLAIM**

The ornamental design for an electronics package, as shown
and described.

DESCRIPTION

FIG. 1 is a front perspective view of the electronics package.
 FIG. 2 is a left side elevation view of the electronics package
 depicted in FIG. 1.
 FIG. 3 is right side elevation view of the electronics package
 depicted in FIG. 1.
 FIG. 4 is a front elevation view of the electronics package
 depicted in FIG. 1.
 FIG. 5 is a rear elevation view of the electronics package
 depicted in FIG. 1.
 FIG. 6 is a top plan view of the electronics package depicted
 in FIG. 1; and,
 FIG. 7 is a bottom plan view of the electronics package
 depicted in FIG. 1.

1 Claim, 3 Drawing Sheets

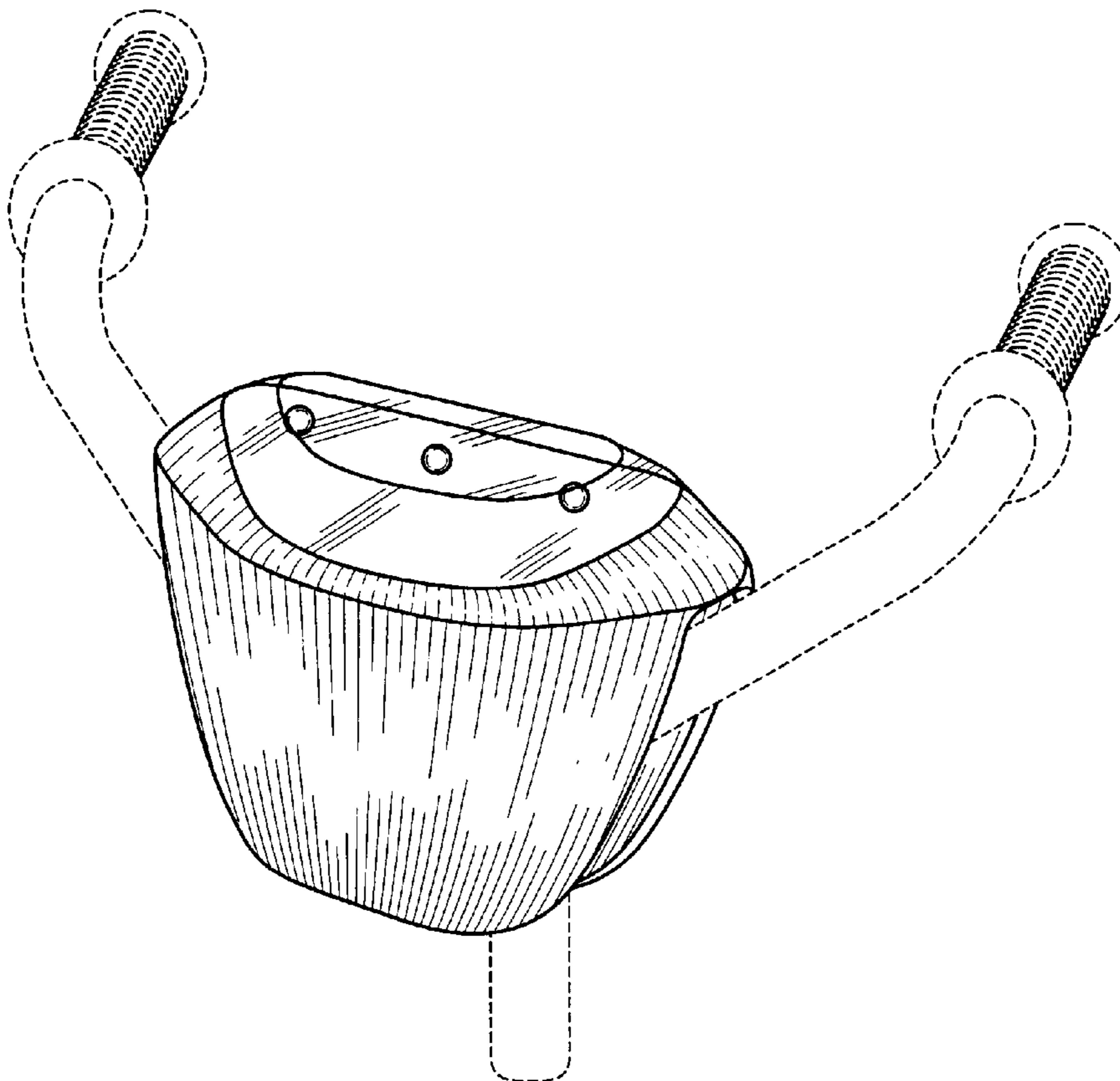

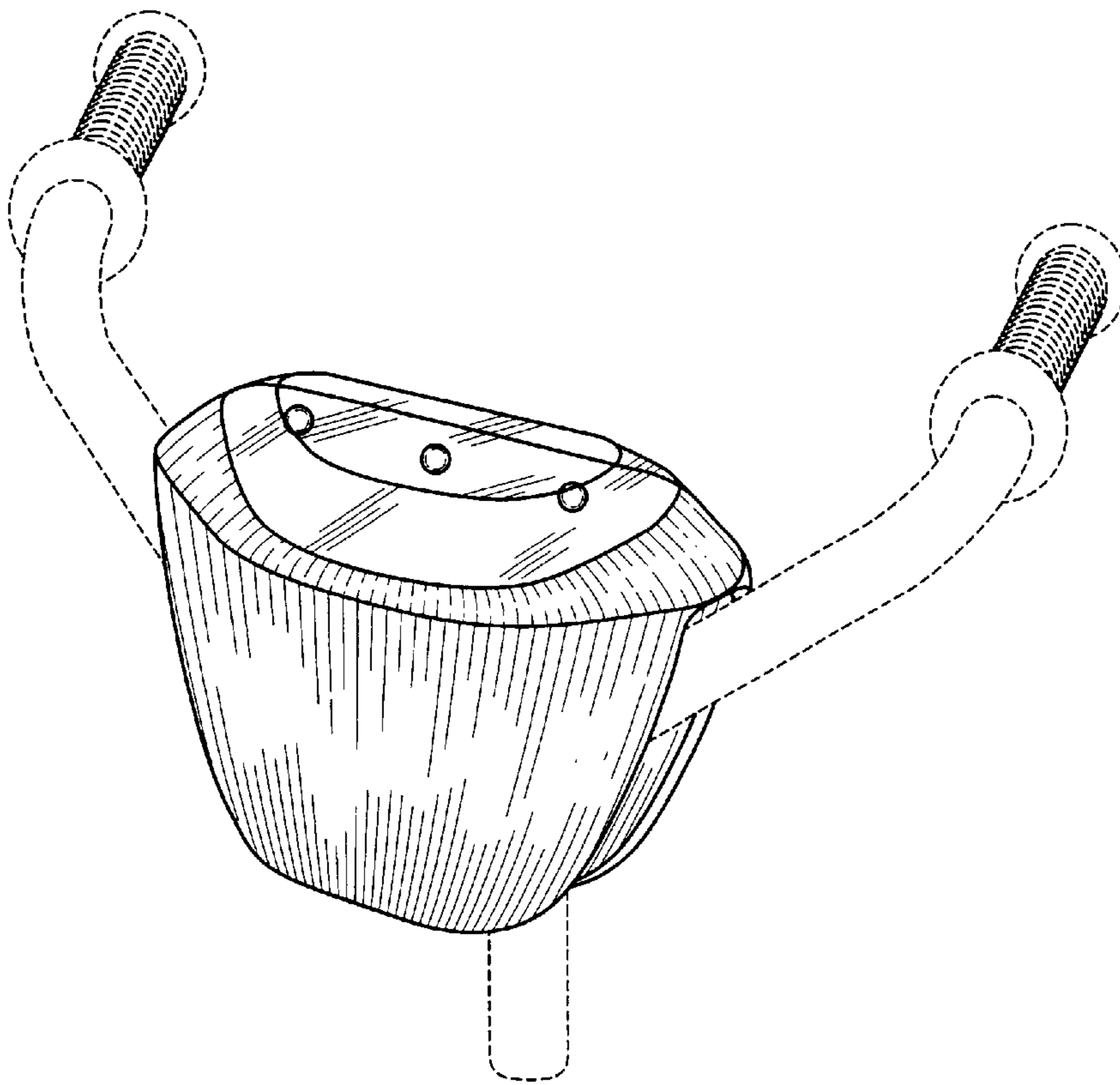

FIG. 1

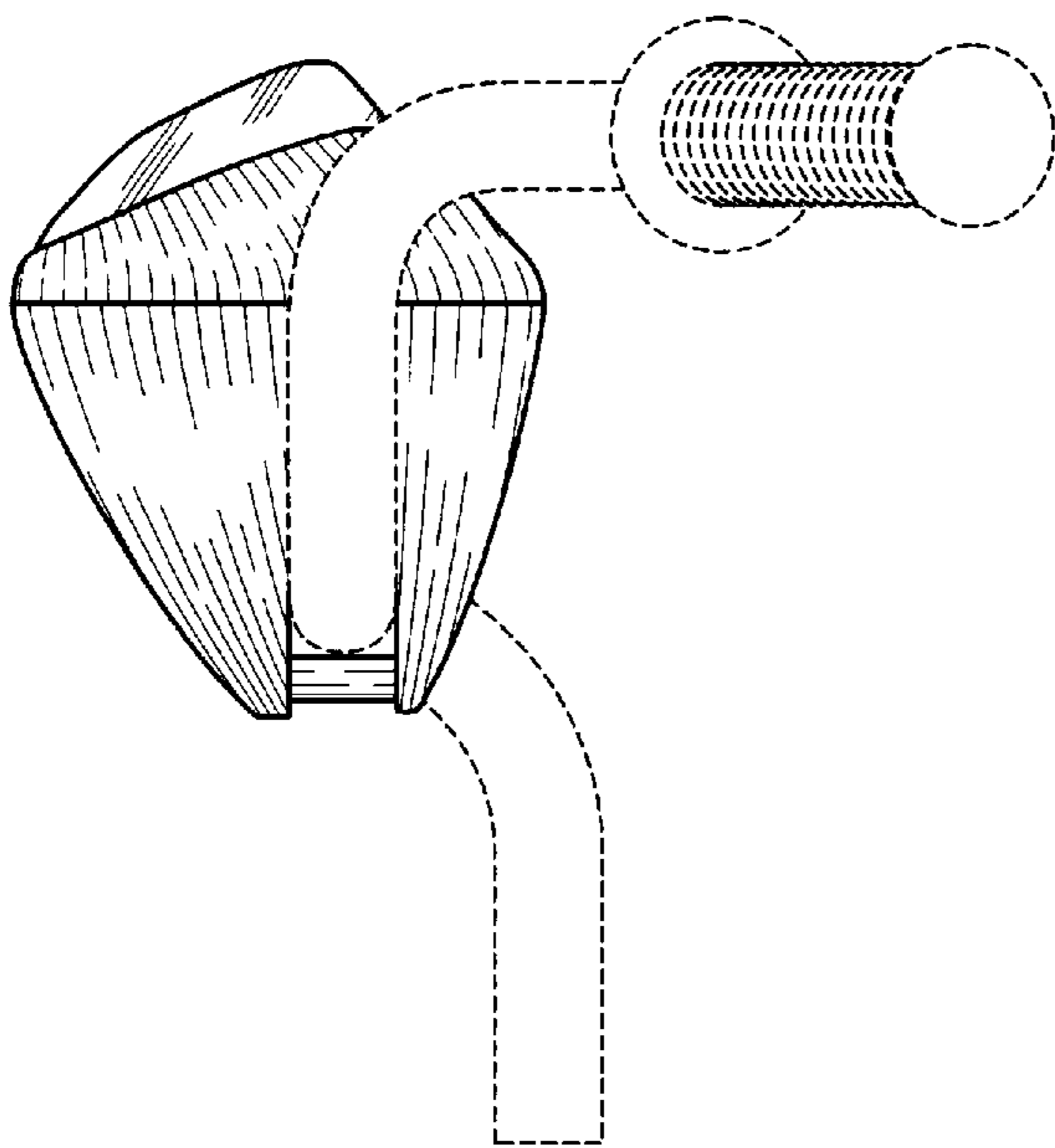

FIG. 2

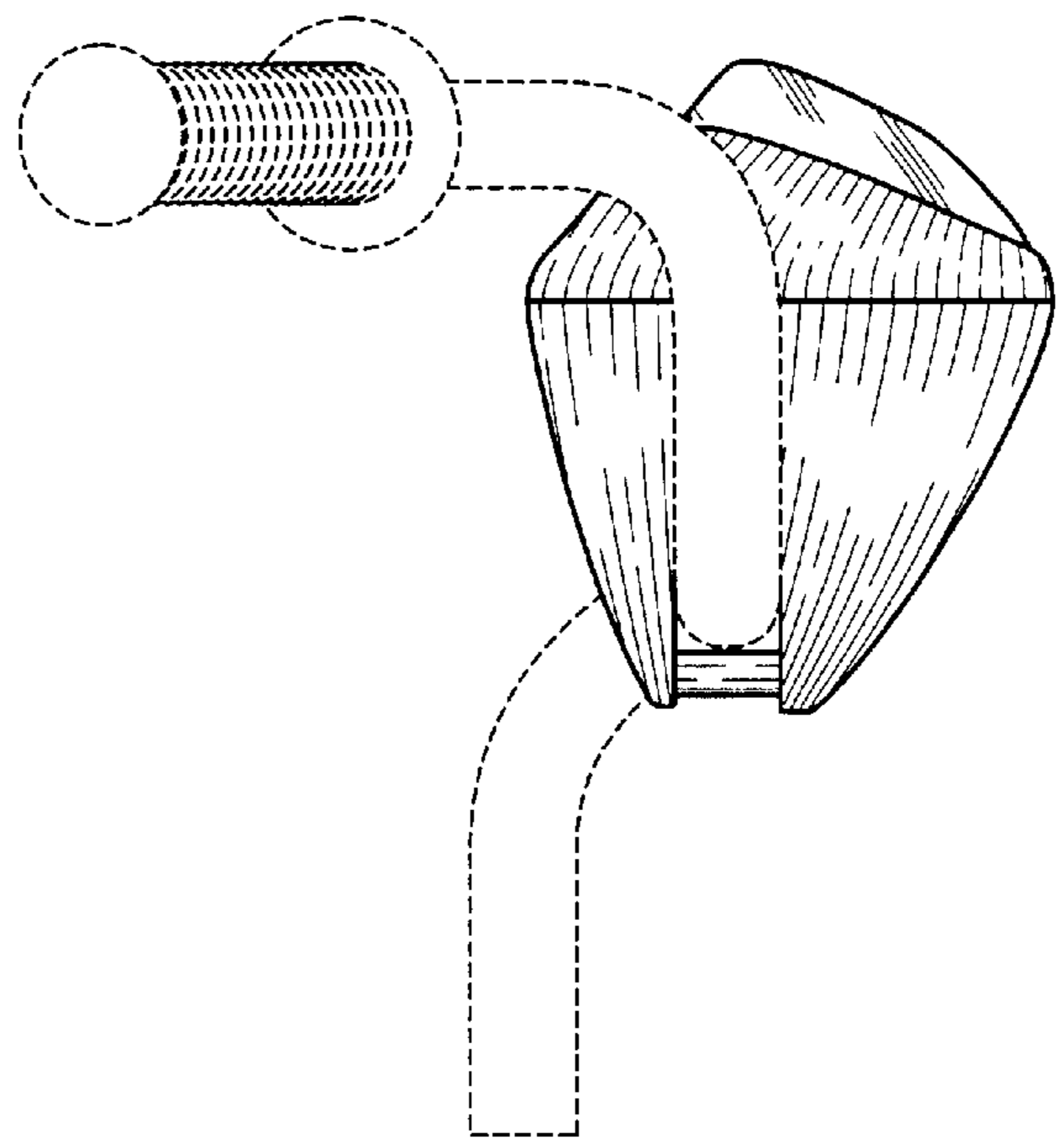

FIG. 3

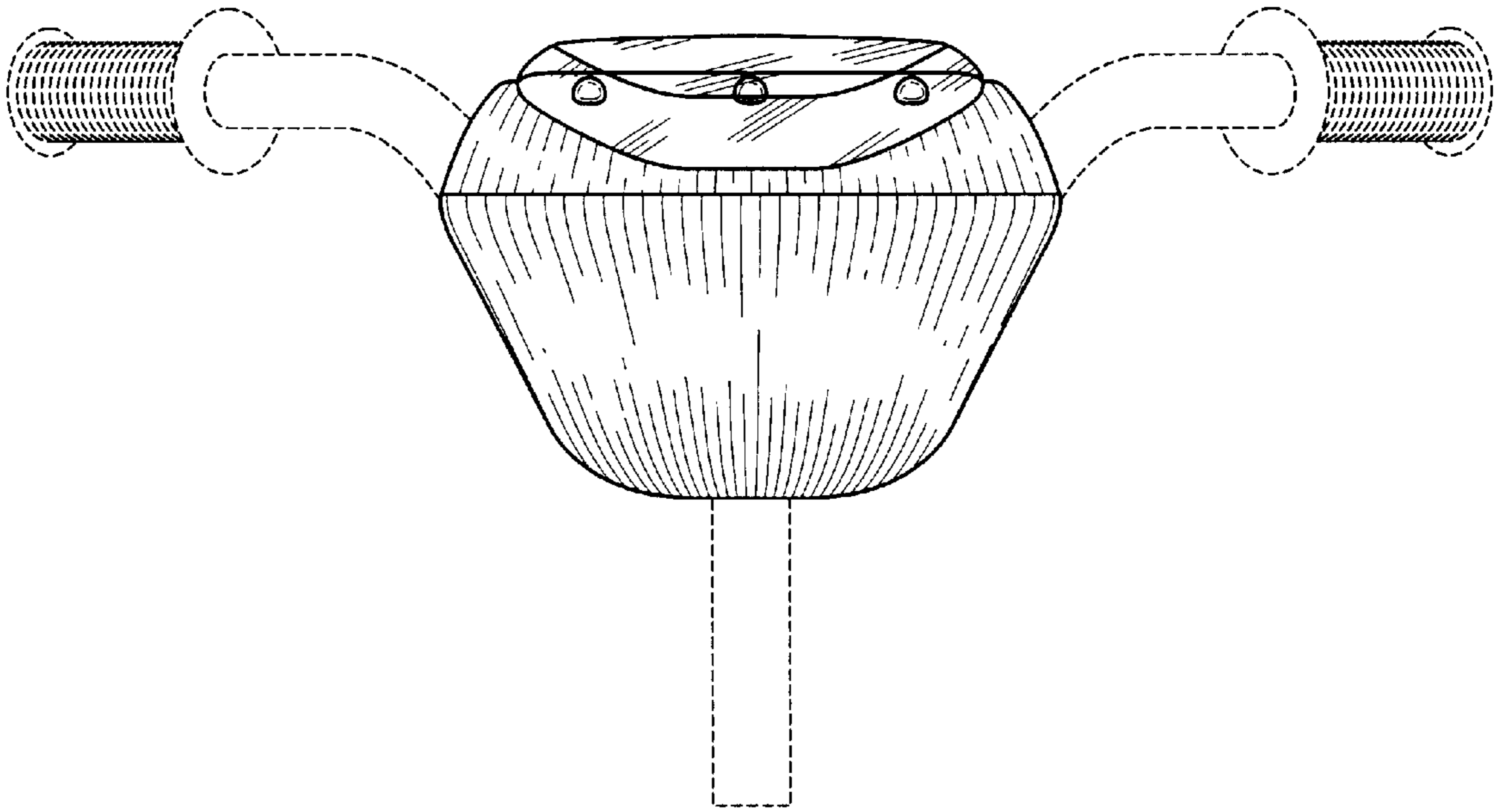

FIG. 4

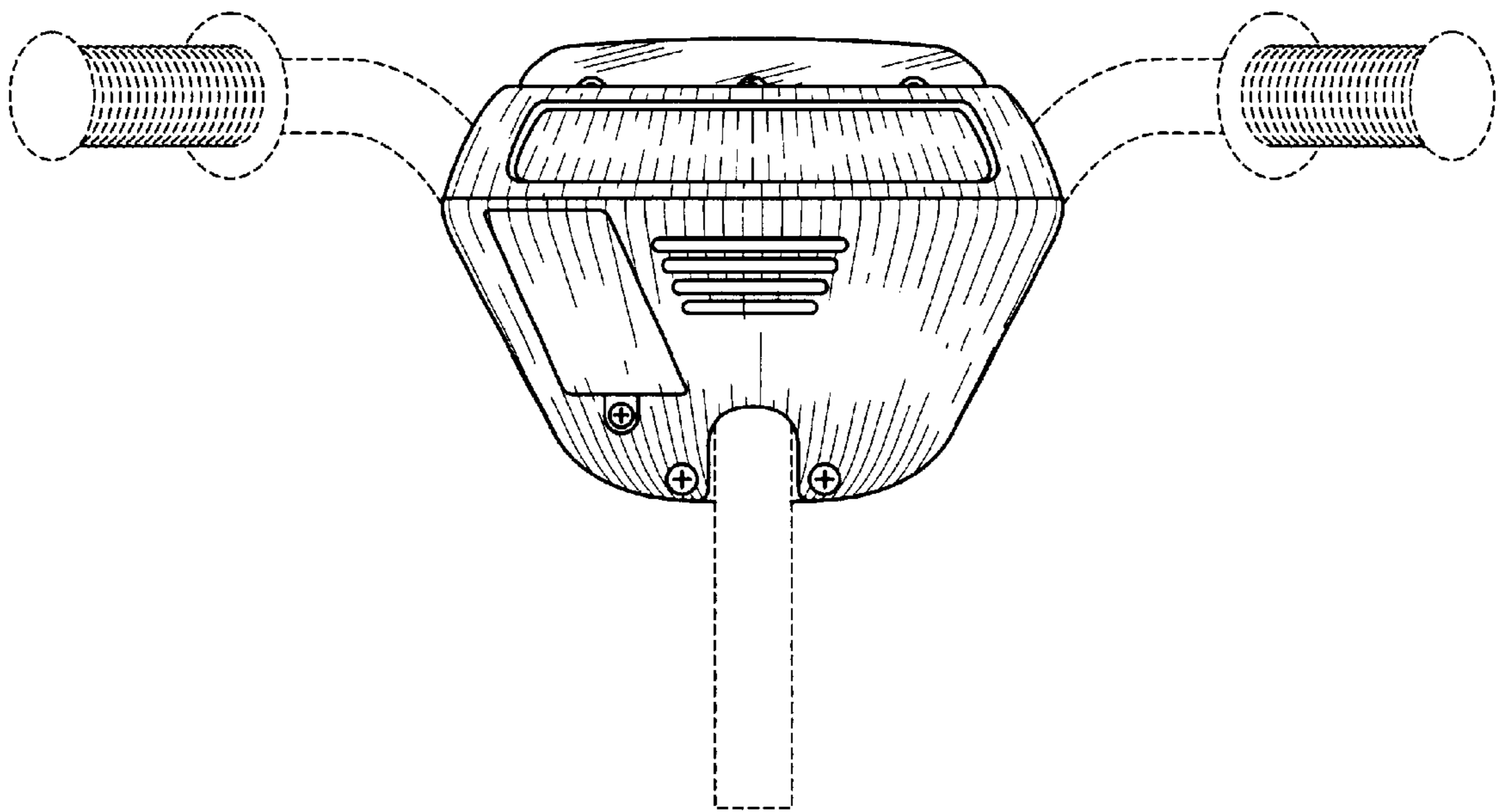

FIG. 5

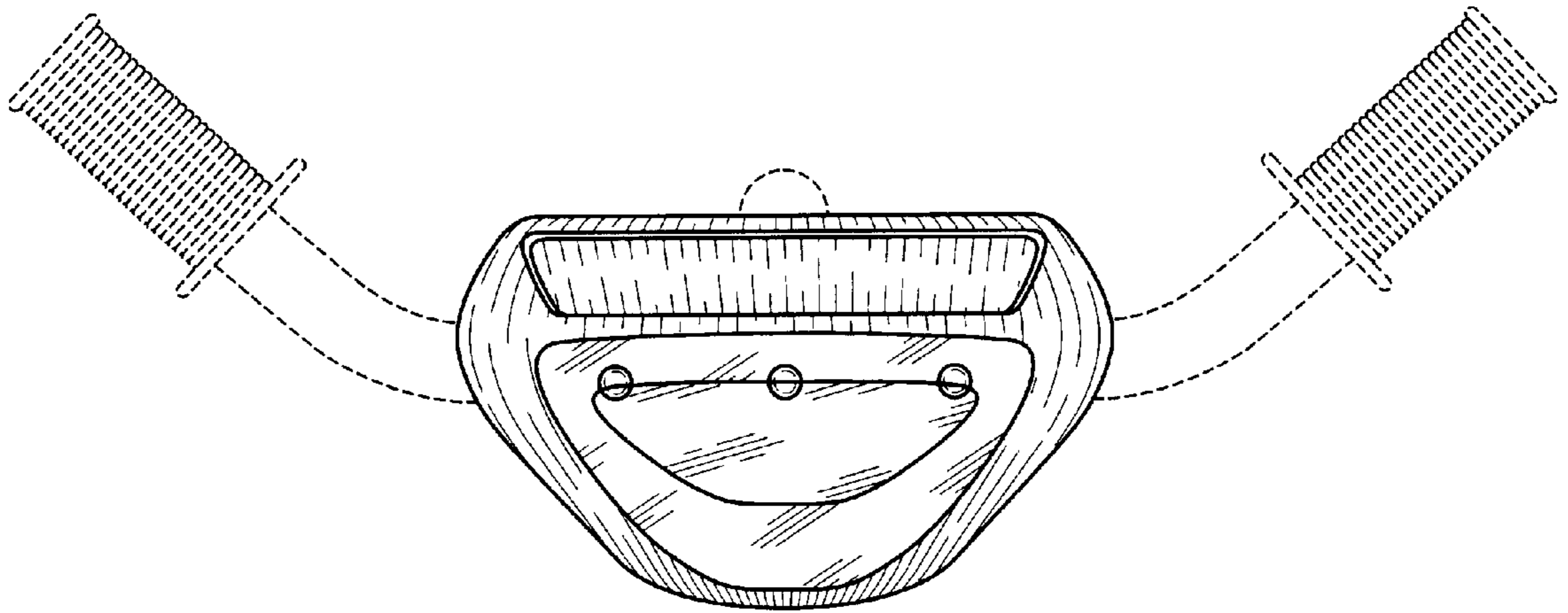

FIG. 6

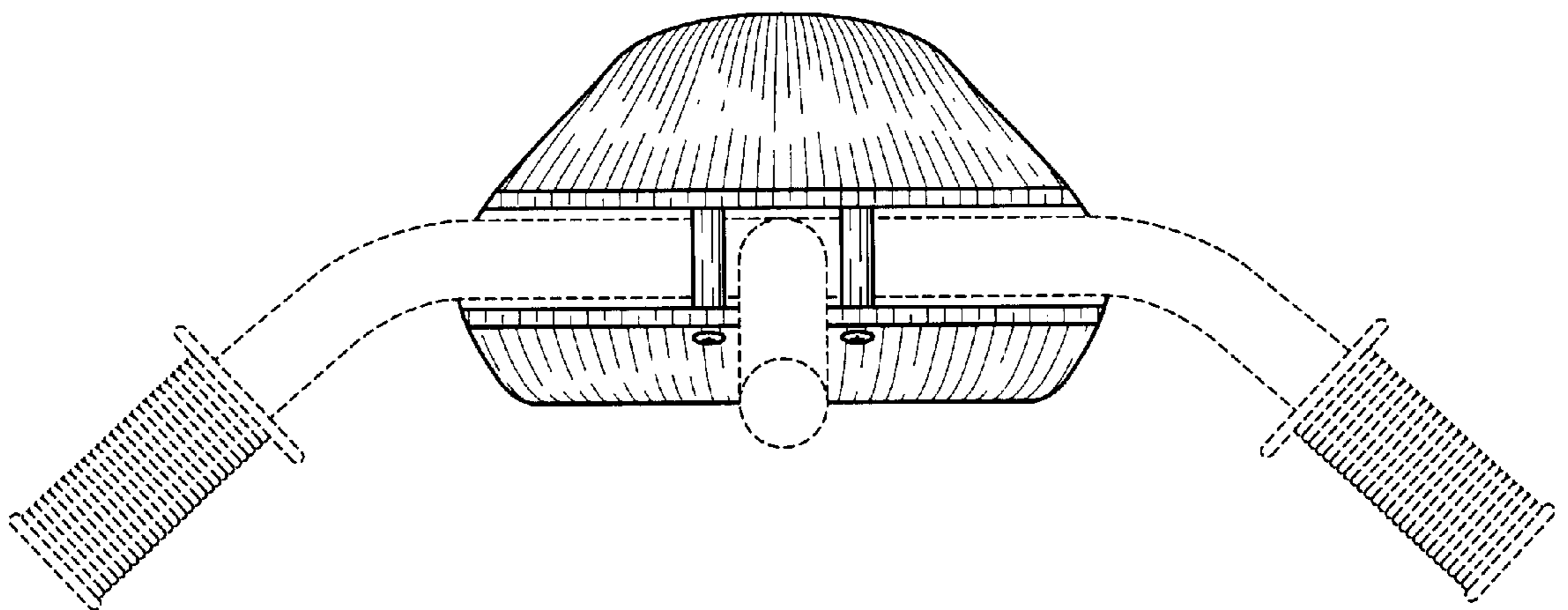

FIG. 7