



US00D484144S

(12) **United States Design Patent**
Sanschagrín et al.

(10) **Patent No.:** **US D484,144 S**

(45) **Date of Patent:** **** Dec. 23, 2003**

(54) **ELEMENTS OF A COWLING**

(75) Inventors: **Stéphane Sanschagrín**, St-Hyacinthe (CA); **Pierre Vignau**, Montreal (CA)

(73) Assignee: **Bombardier Motor Corporation of America**, Grant, FL (US)

(**) Term: **14 Years**

(21) Appl. No.: **29/175,384**

(22) Filed: **Feb. 4, 2003**

Related U.S. Application Data

(63) Continuation of application No. 29/159,706, filed on Apr. 26, 2002.

(51) **LOC (7) Cl.** **15-01**

(52) **U.S. Cl.** **D15/4**

(58) **Field of Search** D15/1-45; 440/3-6, 440/52, 88; 123/495; 240/43-46, 54

(56) **References Cited**

U.S. PATENT DOCUMENTS

D412,911 S	8/1999	Iekura	
D418,519 S	1/2000	Iekura	
D422,599 S	4/2000	Iekura	
D428,616 S	7/2000	Iekura	
D453,772 S	* 2/2002	Burmeister et al.	D15/4
D457,166 S	5/2002	Burmesiter et al.	
D458,273 S	6/2002	Burmeister et al.	
D463,448 S	9/2002	Osumi et al.	
D474,784 S	* 5/2003	Sansshayrin et al.	D15/4

OTHER PUBLICATIONS

- <http://www.evinrude.com/evinrude/web/jsp/mainPage.jsp?Params=N.US.200001.0>, Copyright 2001.
- <http://www.evinrude.com/evinrude/web/jsp/mainPage.jsp?Params=N.US.200002.0>, Copyright 2001.
- <http://www.evinrude.com/evinrude/web/jsp/mainPage.jsp?Params=N.US.200003.0>, Copyright 2001.
- <http://www.evinrude.com/evinrude/web/jsp/mainPage.jsp?Params=N.US.200004.0>, Copyright 2001.

- <http://www.johnson.com/Johnson/web/jsp/mainPage.jsp?Params=N.US.200008.0>, Copyright 2001.
- <http://www.johnson.com/Johnson/web/jsp/mainPage.jsp?Params=N.US.200009.0>, Copyright 2001.
- <http://www.johnson.com/Johnson/web/jsp/mainPage.jsp?Params=N.US.200001.0>, Copyright 2001.
- <http://www.johnson.com/Johnson/web/jsp/mainPage.jsp?Params=N.US.200002.0>, Copyright 2001.
- <http://www.johnson.com/Johnson/web/jsp/mainPage.jsp?Params=N.US.200004.0>, Copyright 2001.
- <http://www.johnson.com/Johnson/web/jsp/mainPage.jsp?Params=N.US.200005.0>, Copyright 2001.
- <http://www.hondabf225.com/bf225.htm>, Copyright 2000.
- <http://www.honda-marine.com/bf225.htm>, Copyright 2000.
- <http://www.honda-marine.com/bf130.htm>, Copyright 2000.
- <http://www.honda-marine.com/bf90.htm>, Copyright 2000.
- <http://www.honda-marine.com/bf50.htm>, Copyright 2000.
- <http://www.honda-marine.com/bf40.htm>, Copyright 2000.
- <http://www.honda-marine.com/bf30.htm>, Copyright 2000.
- <http://www.honda-marine.com/bf15.htm>, Copyright 2000.
- <http://www.honda-marine.com/bf9.9.htm>, Copyright 2000.
- <http://www.honda-marine.com/bf8.htm>, Copyright 2000.

(List continued on next page.)

Primary Examiner—Melody N. Brown
(74) *Attorney, Agent, or Firm*—Pillsbury Winthrop LLP

(57) **CLAIM**

The ornamental design for elements of a cowling, as shown and described.

DESCRIPTION

FIG. 1 is a rear and left side perspective view of an element of a cowling showing our new design;
FIG. 2 is a front view thereof;
FIG. 3 is a left side view thereof, the right side view being a mirror image; and,
FIG. 4 is a top view thereof.
Where included, broken lines showing environment or structure are for illustrative purposes only and form no part of the claimed design.

1 Claim, 3 Drawing Sheets

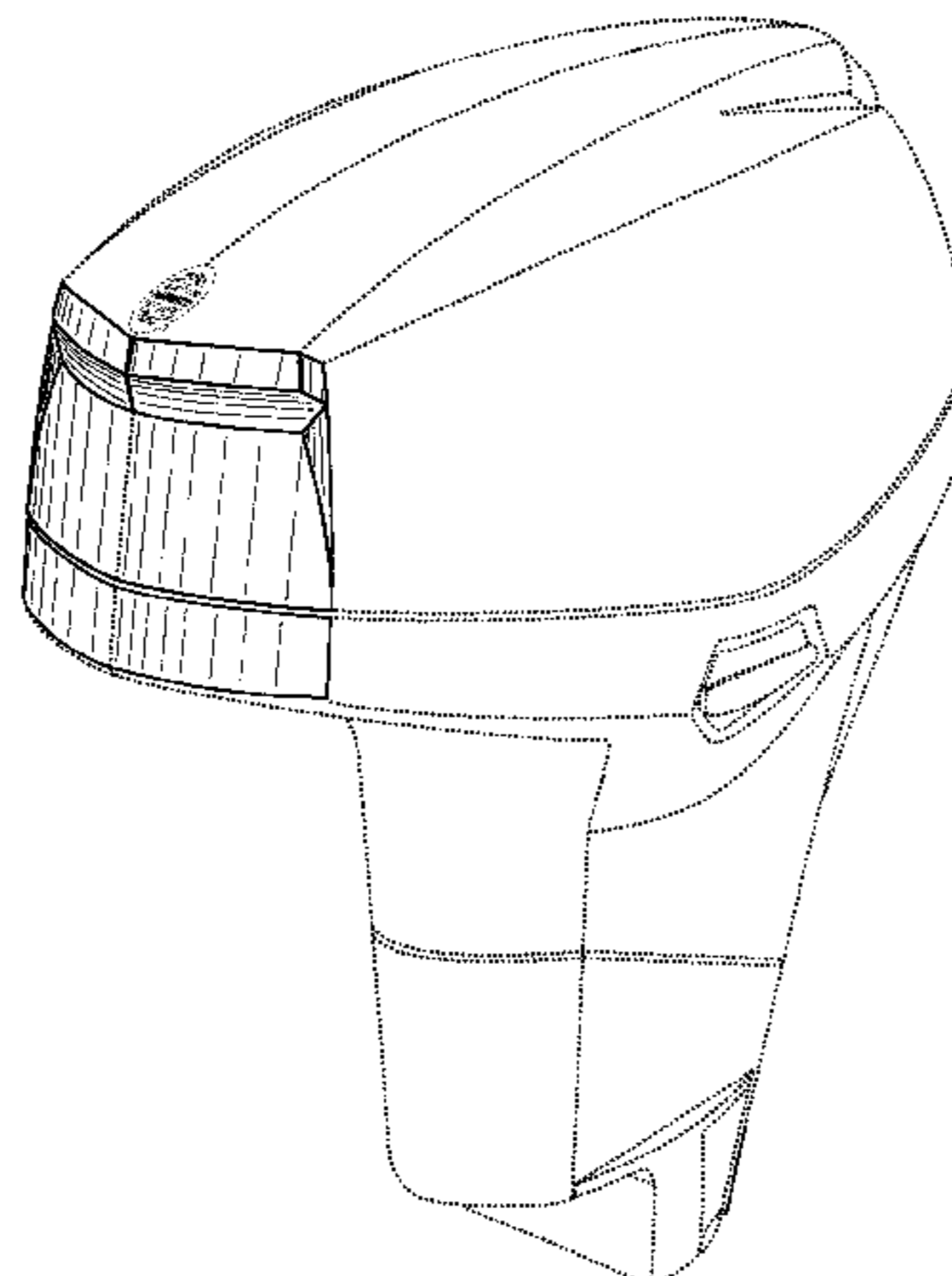

- http://www.mercurymarine.com/cgi-bin/mercprod/MercuryHome/Templates/DotComTemplate.jsp?BV_UseBV-Cookie=no&ParentID=218&page_id=643&ProdID=23259&Area=2.5%20-%205%20hp&BV_SessionID=@@@@0551736409.1035904509@@@@&BV_EngineID=hadcfhklffejbedcfececfj.f.0, Copyright 2002.
- http://www.mercurymarine.com/cgi-bin/mercprod/MercuryHome/Templates/DotComTemplate.jsp?BV_UseBV-Cookie=no&ParentID=null&page_id=643&ProdID=23259&Area=2.5%20-%205%20hp&CurSpecPos=2&BV_SessionID=@@@@0551736409.1035904509@@@@&BV_EngineID=hadcfhklffejbedcfececfj.f.0, Copyright 2002.
- http://www.mercurymarine.com/cgi-bin/mercprod/MercuryHome/Templates/DotComTemplate.jsp?BV_UseBV-Cookie=no&ParentID=null&page_id=643&ProdID=23569&Area=Mid-Range%20FourStroke&BV_SessionID=@@@@0551736409.1035904509@@@@&BV_EngineID=hadcfhklffejbedcfececfj.f.0, Copyright 2002.
- http://www.mercurymarine.com/cgi-bin/mercprod/MercuryHome/Templates/DotComTemplate.jsp?BV_UseBV-Cookie=no&ParentID=null&page_id=643&ProdID=23569&Area=Mid-Range%20FourStroke&CurSpecPos=6&BV_SessionID=@@@@0551736409.1035904509@@@@&BV_EngineID=hadcfhklffejbedcfececfj.f.0, Copyright 2002.
- http://www.mercurymarine.com/cgi-bin/mercprod/MercuryHome/Templates/DotComTemplate.jsp?BV_UseBV-Cookie=no&ParentID=218&page_id=643&ProdID=23259&Area=2.5%20-%205%20hp&BV_SessionID=@@@@0551736409.1035904509@@@@&BV_EngineID=hadcfhklffejbedcfececfj.f.0, Copyright 2002.
- http://www.mercurymarine.com/cgi-bin/mercprod/MercuryHome/Templates/DotComTemplate/jsp?BV_UseBV-Cookie=no&ParentID=null&page_id=643&ProdID=23259&Area=2.5%20-%205%20hp&CurSpecPos=2&BV_SessionID=@@@@0551736409.1035904509@@@@&BV_EngineID=hadcfhklffejbedcfececfj.f.0, Copyright 2002.
- http://www.mercurymarine.com/cgi-bin/mercprod/MercuryHome/Templates/DotComTemplate.jsp?BV_UseBV-Cookie=no&ParentID=null&page_id=648&ProdID=23685&Area=Performance%20Outboards&CurSpecPos=4&BV_SessionID=@@@@0551736409.1035904509@@@@&BV_EngineID=hadcfhklffejbedcfececfj.f.0, Copyright 2002.
- http://www.mercurymarine.com/cgi-bin/mercprod/MercuryHome/Templates/DotComTemplate.jsp?BV_UseBV-Cookie=no&ParentID=202&page_id=648&ProdID=23705&Area=Race%20Outboards&BV_SessionID=@@@@0551736409.1035904509@@@@&BV_EngineID=hadcfhklffejbedcfececfj.f.0, Copyright 2002.
- http://www.mercurymarine.com/cgi-bin/mercprod/MercuryHome/Templates/DotComTemplate.jsp?BV_UseBV-Cookie=no&ParentID=null&page_id=648&ProdID=23705&Area=Race%20Outboards&CurSpecPos=1&BV_SessionID=@@@@0551736409.1035904509@@@@&BV_EngineID=hadcfhklffejbedcfececfj.f.0, Copyright 2002.
- <http://www.yamaha-motor.com/products/subcatinfo.asp?lid=5&1c=otb&cid=19&scid=1&year=2003&cat=Four+Stroke+Series&scat=High+Power>, Copyright 1996-2002.
- <http://www.yamaha-motor.com/products/subcatinfo.asp?lid=5&1c=otb&cid=19&scid=2&year=2003&car=Four+Stroke+Series&scat=Midrange>, Copyright 1996-2002.
- <http://www.yamaha-motor.com/products/subcatinfo.asp?lid=5&1c=otb&cid=19&scid=3&year=2003&cat=Four+Stroke+Series&scat=Jet+Drive>, Copyright 1996-2002.
- <http://www.yamaha-motor.com/products/subcatinfo.asp?lid=5&1c=otb&cid=19&scid=4&year=2003&cat=Four+Stroke+Series&scat=High+Thrust>, Copyright 1996-2002.
- <http://www.yamaha-motor.com/products/subcatinfo.asp?lid=5&1c=otb&cid=19&scid=5&year=2003&cat=Four+Stroke+Series&scat=Portable>, Copyright 1996-2002.
- http://www.yamaha-motor.com/products/catinfo.asp?lid=5&1c32_otb&cid=11&year=2003&cat=HPDI+Series, Copyright 1996-2002.
- <http://www.yamaha-motor.com/products/subcatinfo.asp?lid=5&1c=otb&cid=18&scid=7&year=2003&cat=V+MAX+Series&scat=HPDI>, Copyright 1996-2002.
- <http://www.yamaha-motor.com/products/subcatinfo.asp?lid=5&1c=otb&cid=18&scid=6&year=2003&cat=V+MAX+Series&scat=3%2E1L+Big+Block>, Copyright 1996-2002.
- <http://www.yamaha-motor.com/products/subcatinfo.asp?lid=5&1c=otb&cid=18&scid=8&year=2003&cat=V+MAX+Series&scat=2%2E6L+OX66+%2F+Carb>, Copyright 1996-2002.
- <http://www.yamaha-motor.com/products/subcatinfo.asp?lid=5&1c=otb&cid=20&scid=12&year=2003&cat=Two+Stroke+Series&scat=OX66+Saltwater+Series+II>, Copyright 1996-2002.
- <http://www.yamaha-motor.com/products/subcatinfo.asp?lid=5&1c=otb&cid=20&scid=9&year=2003&cat=Two+Stroke+Series&scat=High+Power>, Copyright 1996-2002.
- <http://www.yamaha-motor.com/products/subcatinfo.asp?lid=5&1c=otb&cid=20&scid=10&year=2003&cat=Two+Stroke+Series&scat=Midrange>, Copyright 1996-2002.
- <http://www.yamaha-motor.com/products/subcatinfo.asp?lid=5&1c=otb&cid=20&scid=11&year=2003&cat=Two+Stroke+Series&scat=Portable>, Copyright 1996-2002.
- <http://www.suzukimarine.com/4strokes/index.html>, Copyright 1996-2002.
- <http://www.suzukimarine.com/2strokes/index.html>, Copyright 1996-2002.
- <http://www.suzukimarine.com/sr00/info/frshore.htm>, Copyright 1996-2000.
- <http://www.suzukimarine.com/sr00/info/mid.htm>, Copyright 1996-2000.
- <http://www.suzukimarine.com/sr00/info/mids4.htm>, Copyright 1996-2000.
- <http://www.suzukimarine.com/sr00/info/port.htm>, Copyright 1996-2000.
- <http://www.suzukimarine.com/sr00/info/frperf.htm>, Copyright 1996-2000.
- <http://www.suzukimarine.com/sr97/comp.htm>, Copyright 1996/97.
- <http://www.suzukimarine.com/sr97/port.htm>, Copyright 1996/97.
- <http://www.suzukimarine.com/sr97/fstrok.htm>, Copyright 1996/97.

* cited by examiner

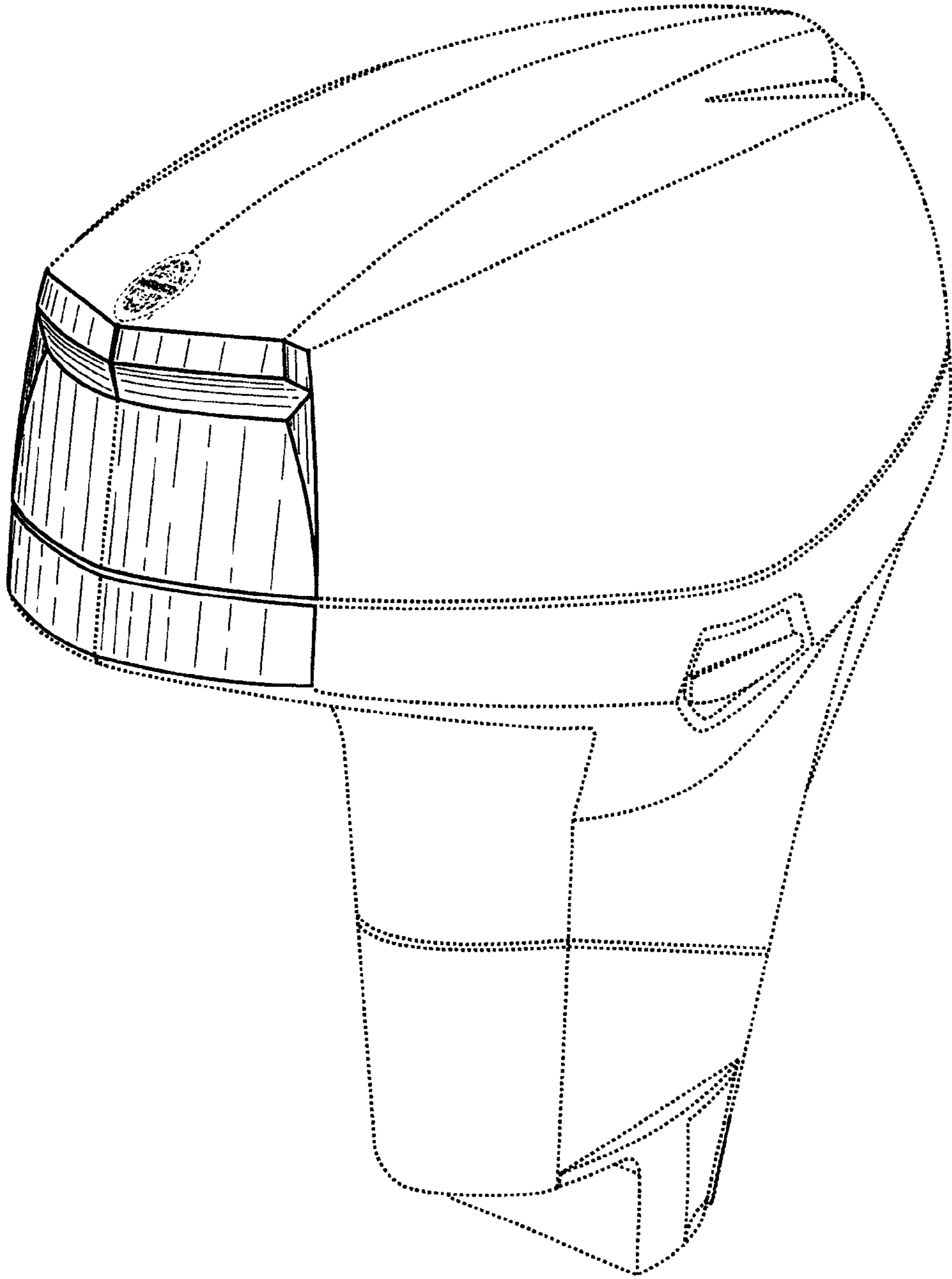

FIG. 1

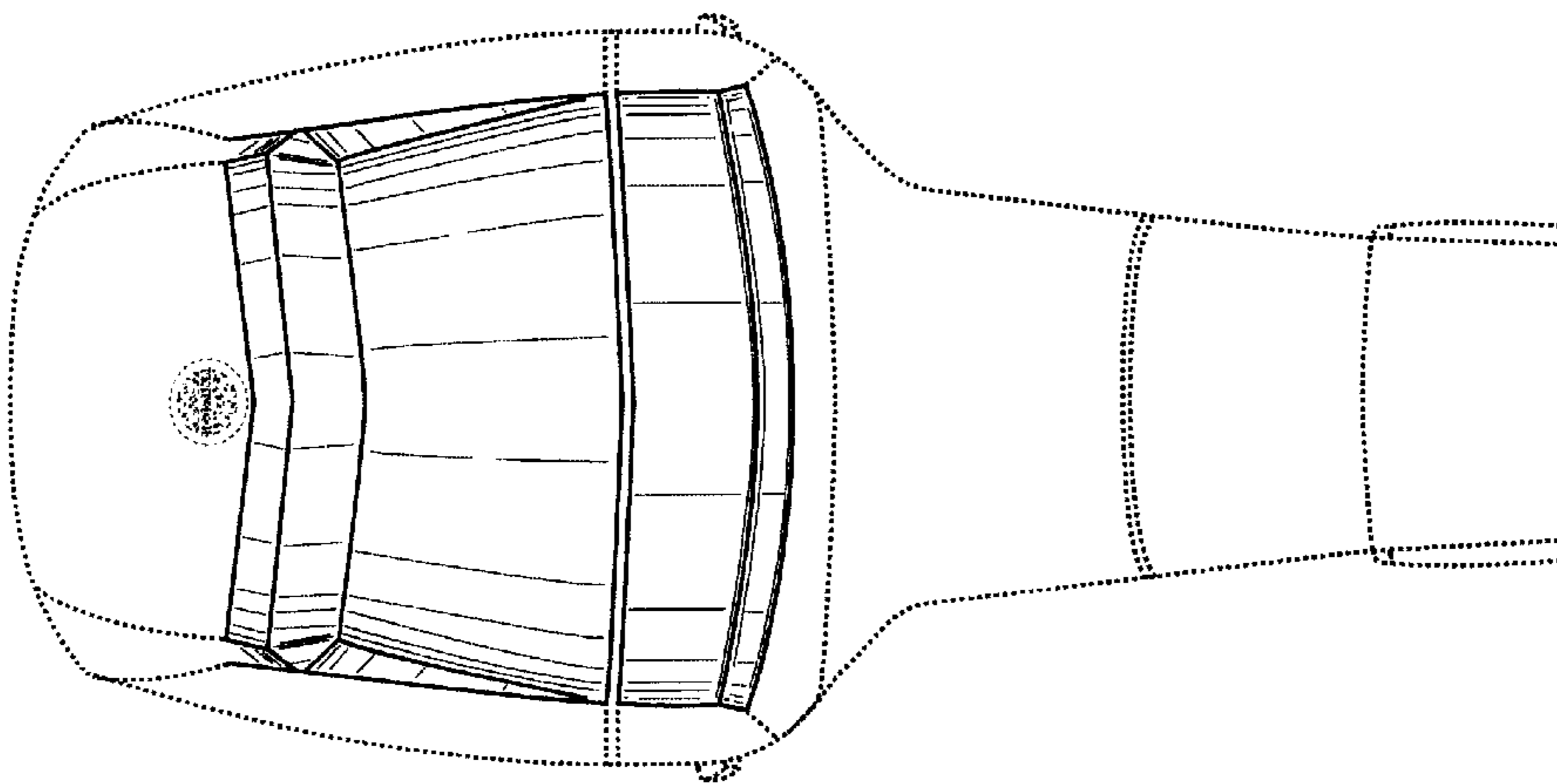

FIG. 2

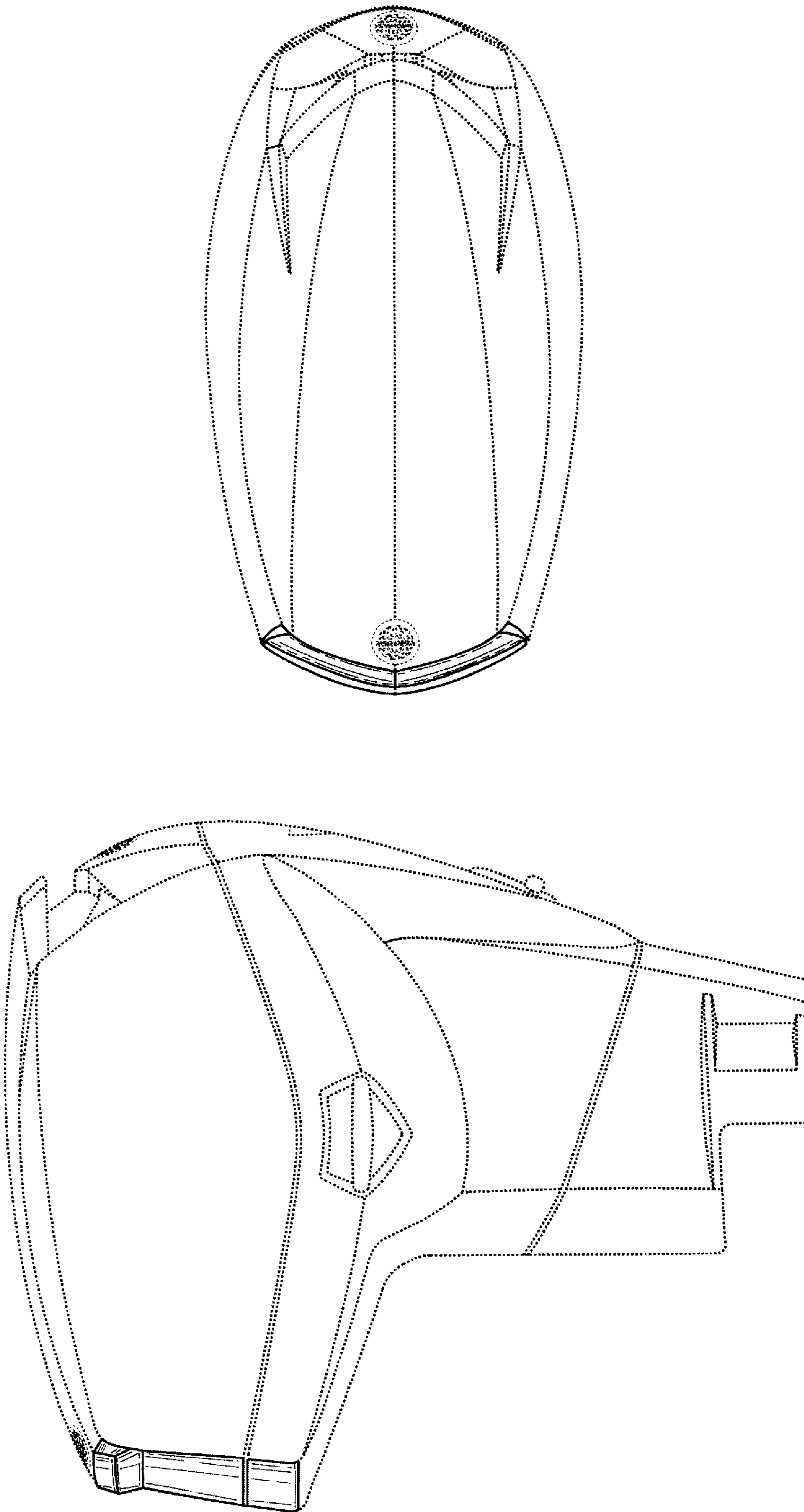

FIG. 4

FIG. 3