



US00D483088S

(12) **United States Design Patent**  
**Zheng**

(10) **Patent No.:** **US D483,088 S**

(45) **Date of Patent:** **\*\* Dec. 2, 2003**

(54) **FLOATING LOUNGER**

D384,721 S \* 10/1997 Peterson ..... D21/809  
D428,099 S \* 7/2000 Peterson ..... D21/803

(75) Inventor: **Yu Zheng**, Walnut, CA (US)

\* cited by examiner

(73) Assignee: **Patent Category Corp.**, Walnut, CA (US)

*Primary Examiner*—Lucy Lieberman

(74) *Attorney, Agent, or Firm*—Raymond Sun

(\*\*) Term: **14 Years**

(57) **CLAIM**

(21) Appl. No.: **29/171,147**

The ornamental design for a floating lounger, as shown and described.

(22) Filed: **Nov. 18, 2002**

(51) **LOC (7) Cl.** ..... **12-06**

**DESCRIPTION**

(52) **U.S. Cl.** ..... **D21/809; D21/803**

(58) **Field of Search** ..... D12/316; 441/129–132, 441/35, 66, 67, 79, 88, 40–43; 297/452.41; 114/345, 346; D6/604, 336, 335; D21/808

FIG. 1 is a perspective view of my floating lounger; FIG. 2 is a top plan view of the floating lounger of FIG. 1; FIG. 3 is a bottom plan view of the floating lounger of FIG. 1;

(56) **References Cited**

**U.S. PATENT DOCUMENTS**

1,960,474	A	*	5/1934	Browne	.....	441/129
3,781,933	A	*	1/1974	Soter	.....	441/40
D299,941	S	*	2/1989	Chang	.....	D12/306
4,905,332	A	*	3/1990	Wang	.....	5/655.3
D308,712	S	*	6/1990	Chang	.....	D21/770
5,219,307	A	*	6/1993	Morrison	.....	441/38
5,476,404	A	*	12/1995	Price	.....	441/131

FIG. 4 is a left side elevational view of the floating lounger of FIG. 1, the right side elevational view being symmetrical; FIG. 5 is a rear elevational view of the floating lounger of FIG. 1;

FIG. 6 is a front elevational view of the floating lounger of FIG. 1; and,

FIG. 7 is a perspective view of the floating lounger of FIG. 1 shown in an alternate position.

**1 Claim, 5 Drawing Sheets**

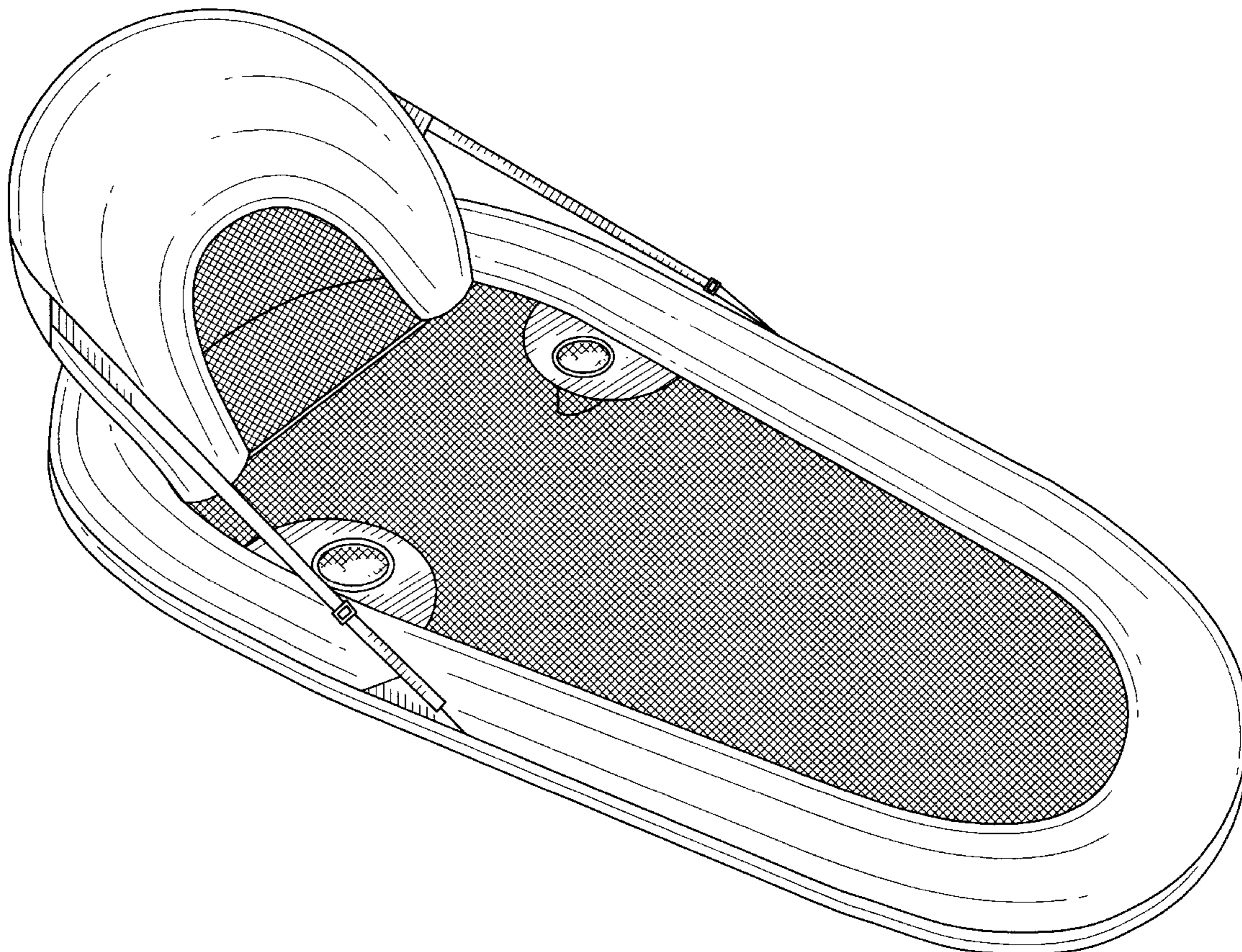



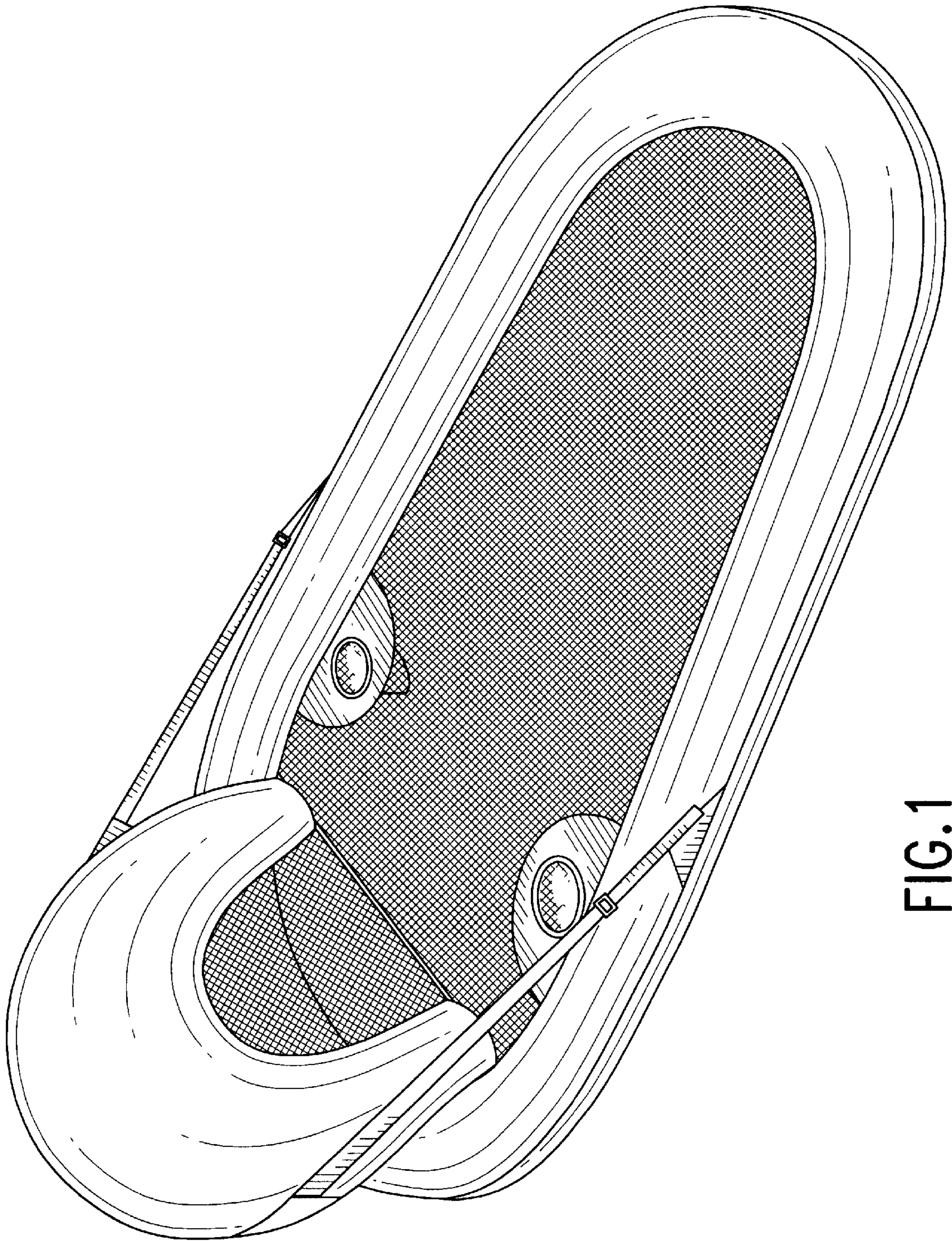

FIG. 1



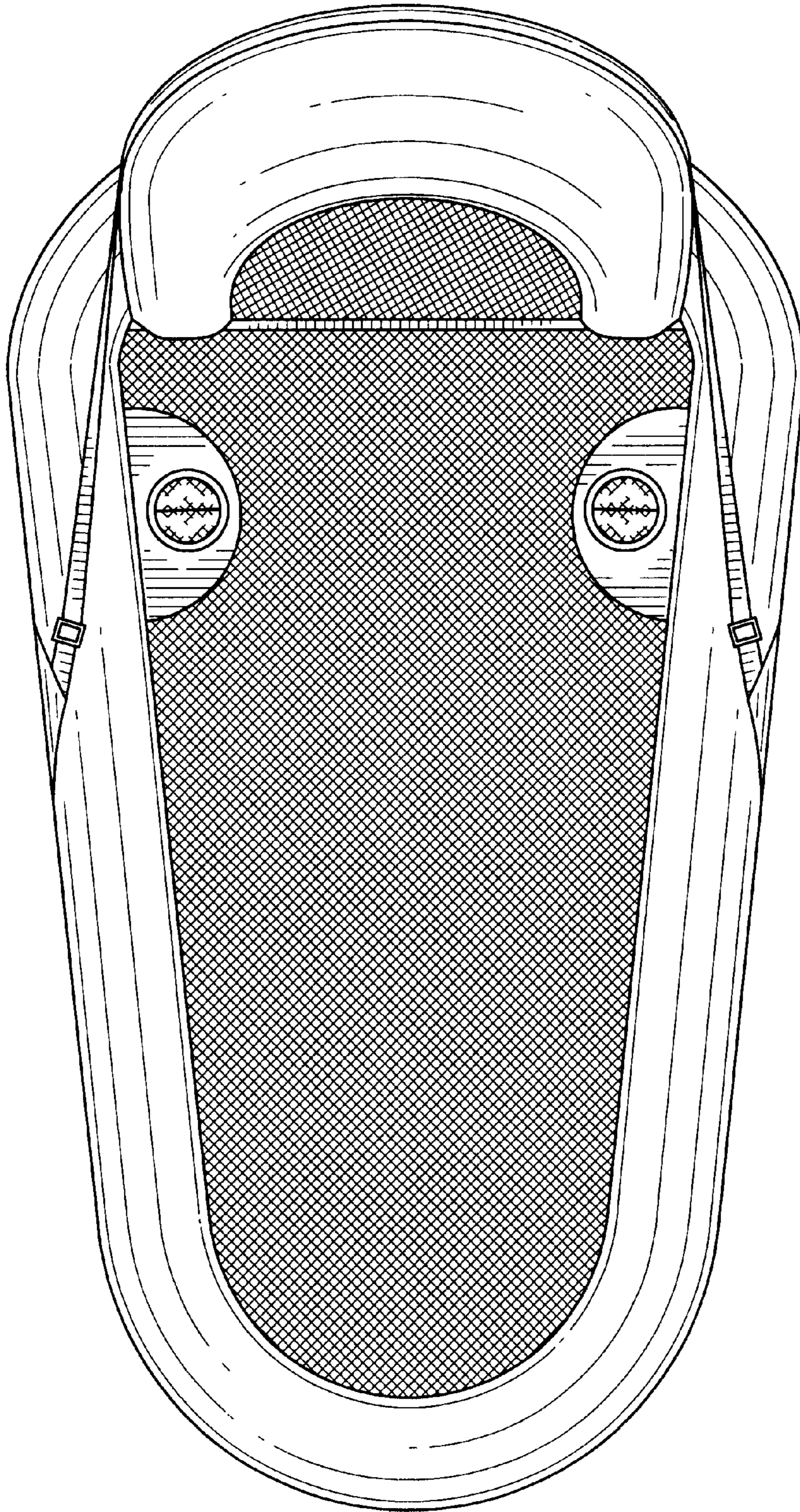

FIG. 2



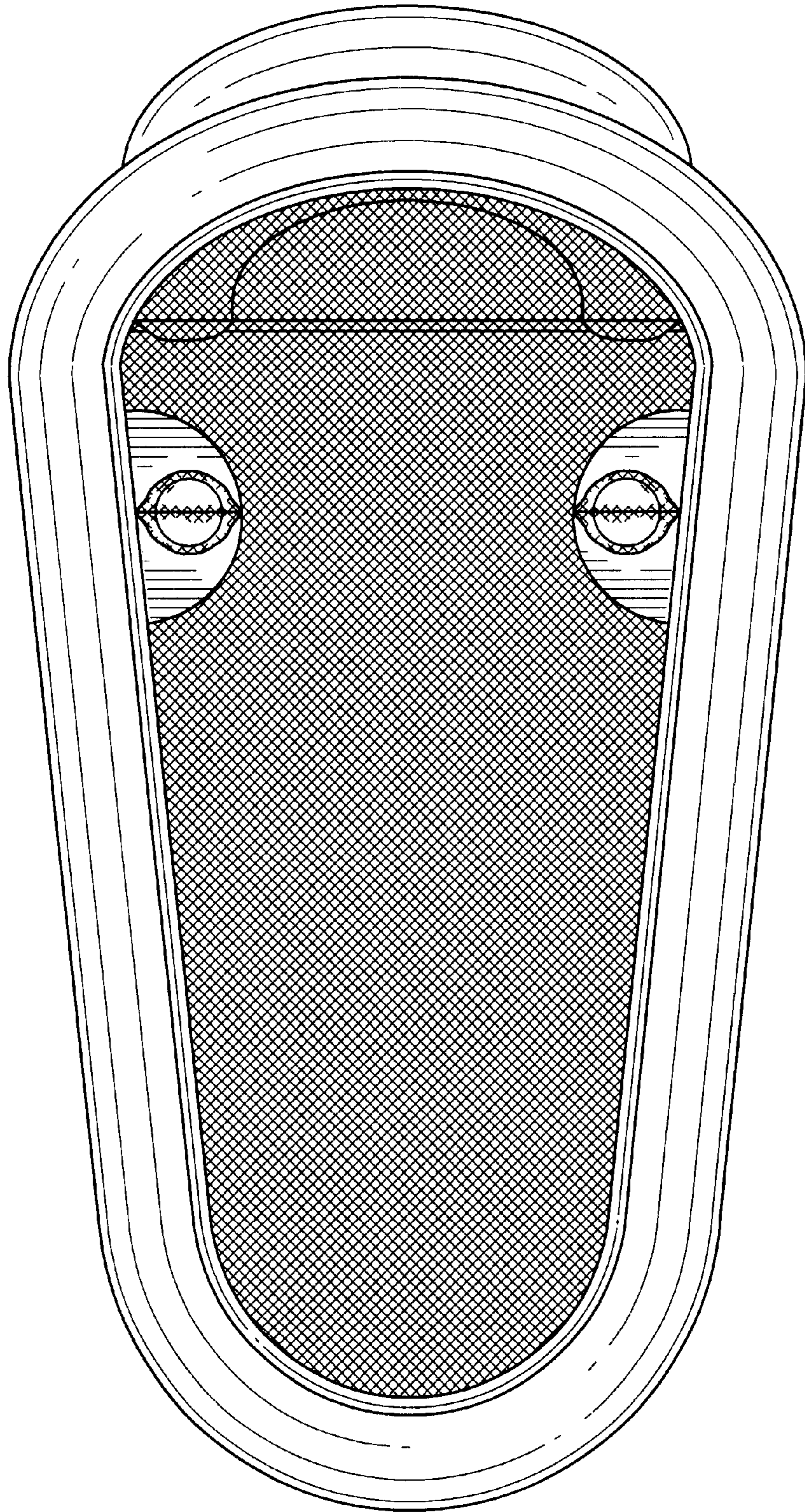

FIG.3

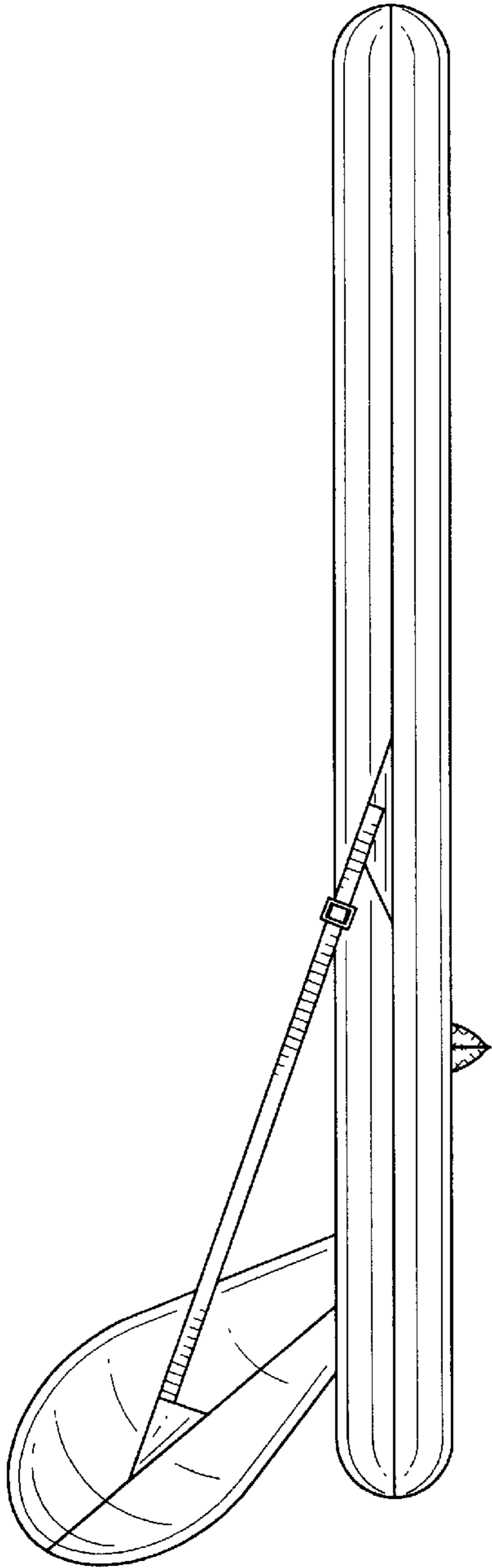

FIG. 4

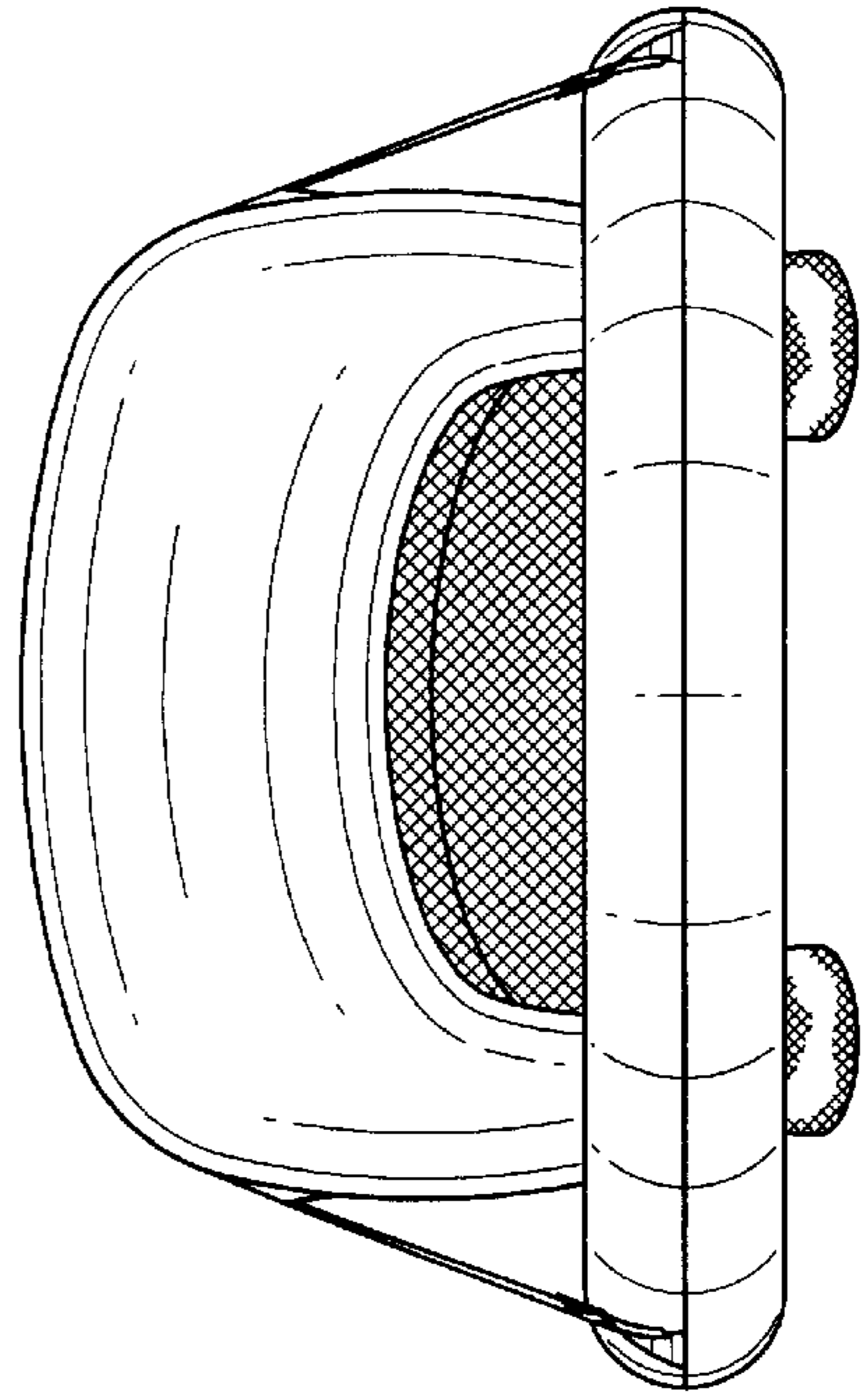

FIG. 6

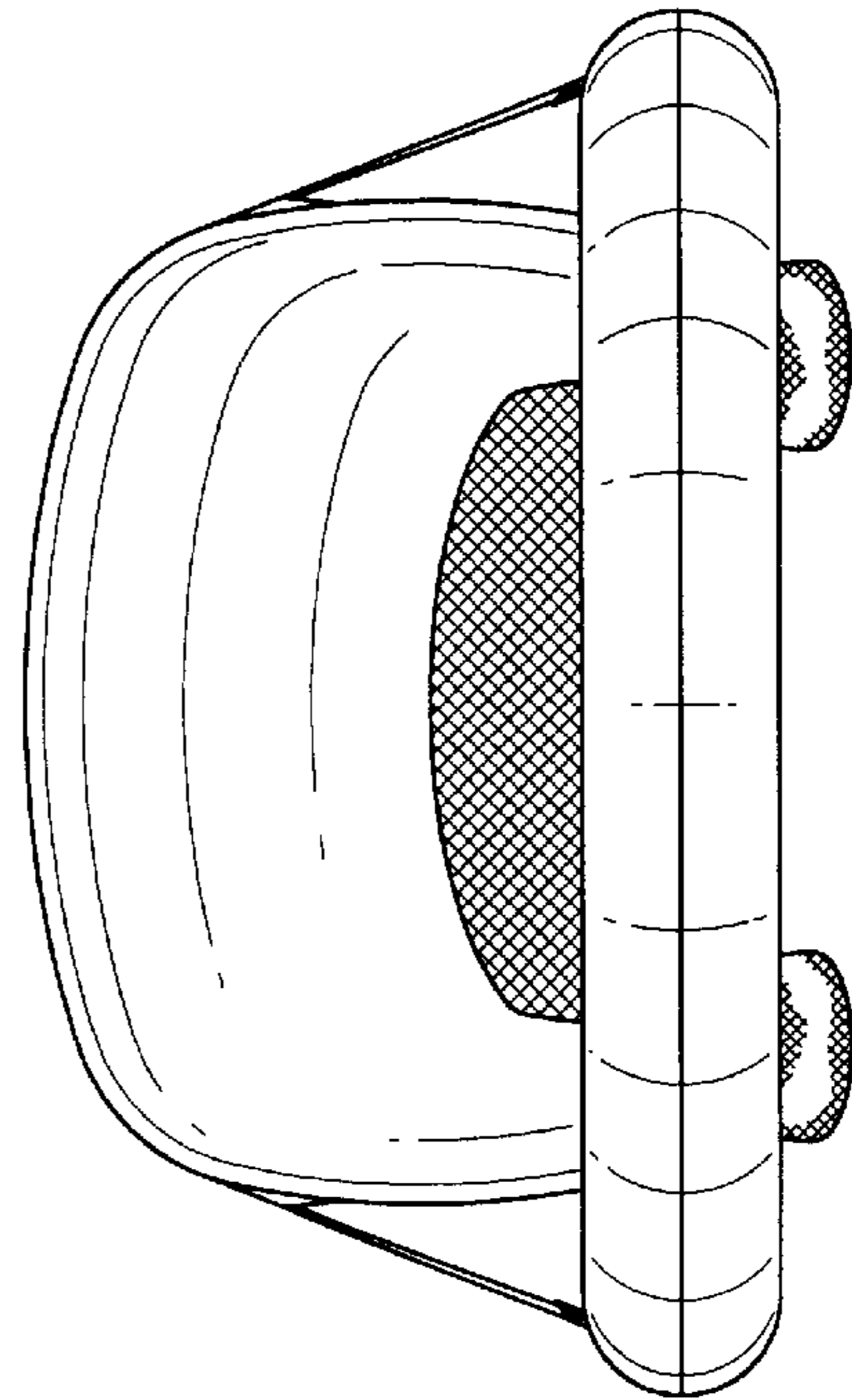

FIG. 5



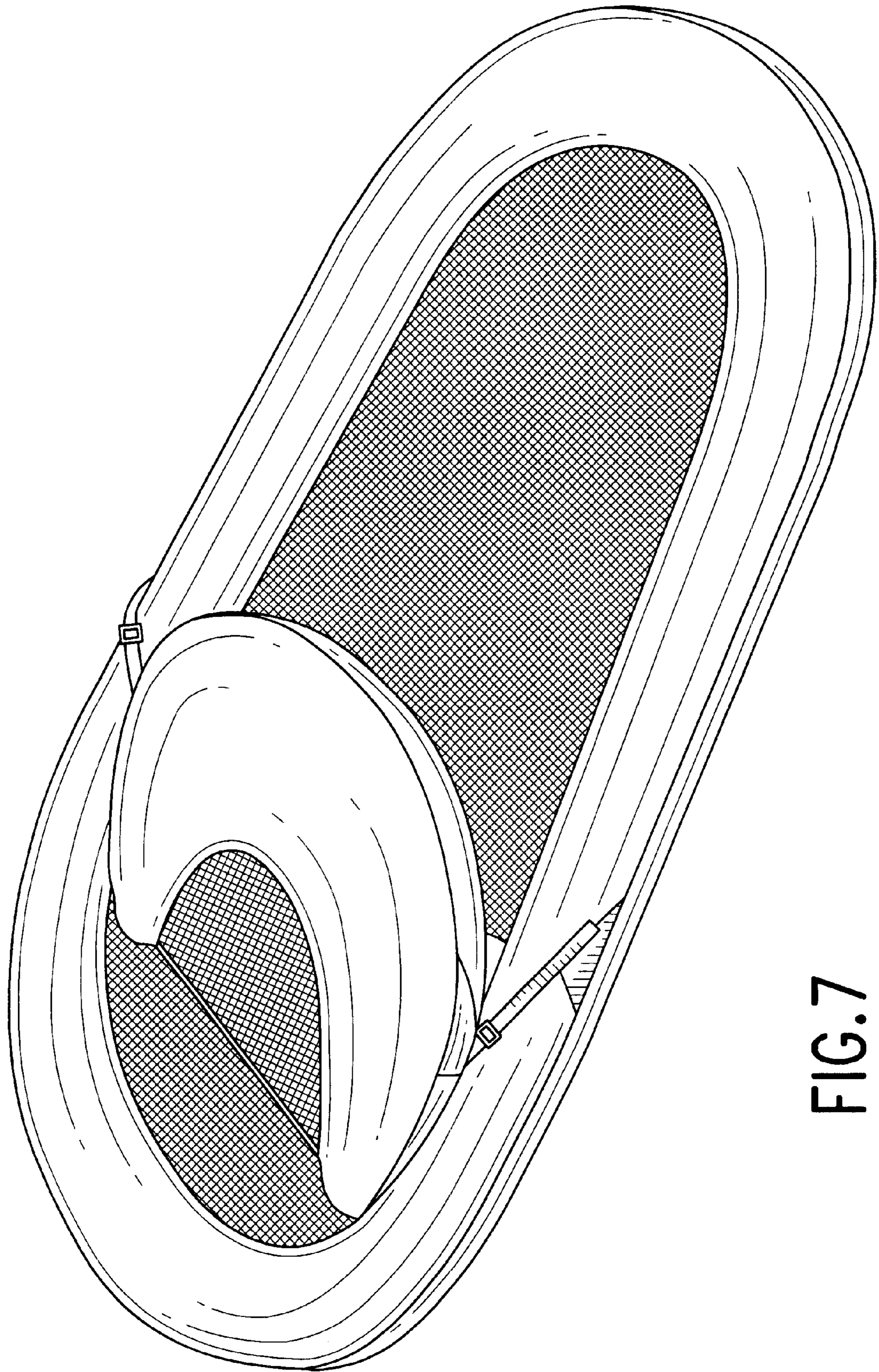

FIG. 7