



US00D482707S

(12) **United States Design Patent**  
**Kowalski**

(10) **Patent No.:** **US D482,707 S**

(45) **Date of Patent:** **\*\* Nov. 25, 2003**

(54) **LINEAR ACTUATOR SHAFT**

6,365,993 B1 \* 4/2002 Calhoon et al. .... 310/12  
6,486,420 B1 \* 11/2002 Boettcher et al. .... 200/50.21

(75) Inventor: **Keith Kowalski**, Bethlehem, CT (US)

\* cited by examiner

(73) Assignee: **Tri-Tech, Inc.**, Waterbury, CT (US)

*Primary Examiner*—Antoine Duval Davis

(\*\*) Term: **14 Years**

(74) *Attorney, Agent, or Firm*—John H. Crozier

(21) Appl. No.: **29/168,352**

(57) **CLAIM**

(22) Filed: **Oct. 1, 2002**

The ornamental design for a linear actuator shaft, as shown and described.

(51) **LOC (7) Cl.** ..... **15-09**

**DESCRIPTION**

(52) **U.S. Cl.** ..... **D15/143**

FIG. 1 is an end/side isometric view of a linear actuator shaft of my new design, with the shaft thereof in extended position;

(58) **Field of Search** ..... D15/143; 74/89.36;  
200/50.21; 218/84; 192/143; 310/12, 30;  
384/42; 403/340, 372; 73/864.18, 864.12;  
464/88; 422/926; 92/117 A, 117 R, 13.3,  
165 R, 143, 139, 42

FIG. 2 is an end/side isometric view thereof, with the shaft in retracted position;

(56) **References Cited**

FIG. 3 is a side elevational view thereof, with the shaft in extended position; and,

**U.S. PATENT DOCUMENTS**

FIG. 4 is an end elevational view thereof; it being understood that the matter shown in broken lines on the drawing figures is for illustrative purposes only and forms no part of the claimed design.

5,187,990 A \* 2/1993 Magnussen, Jr. et al. 73/864.18  
5,570,769 A \* 11/1996 Eicher et al. .... 192/143  
6,073,405 A \* 6/2000 Kasai et al.

**1 Claim, 2 Drawing Sheets**

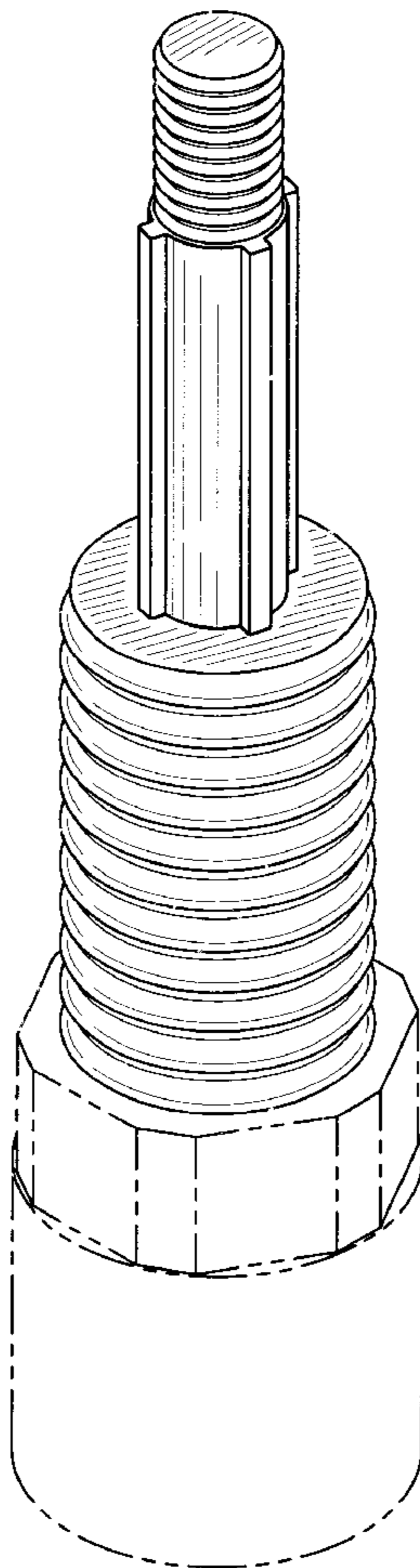

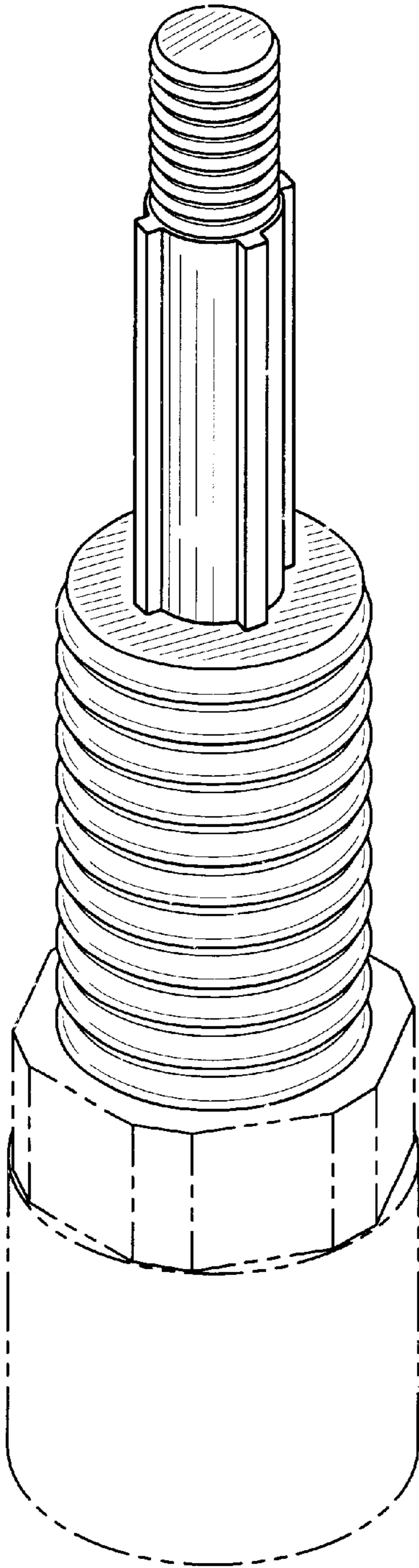

FIG. 1

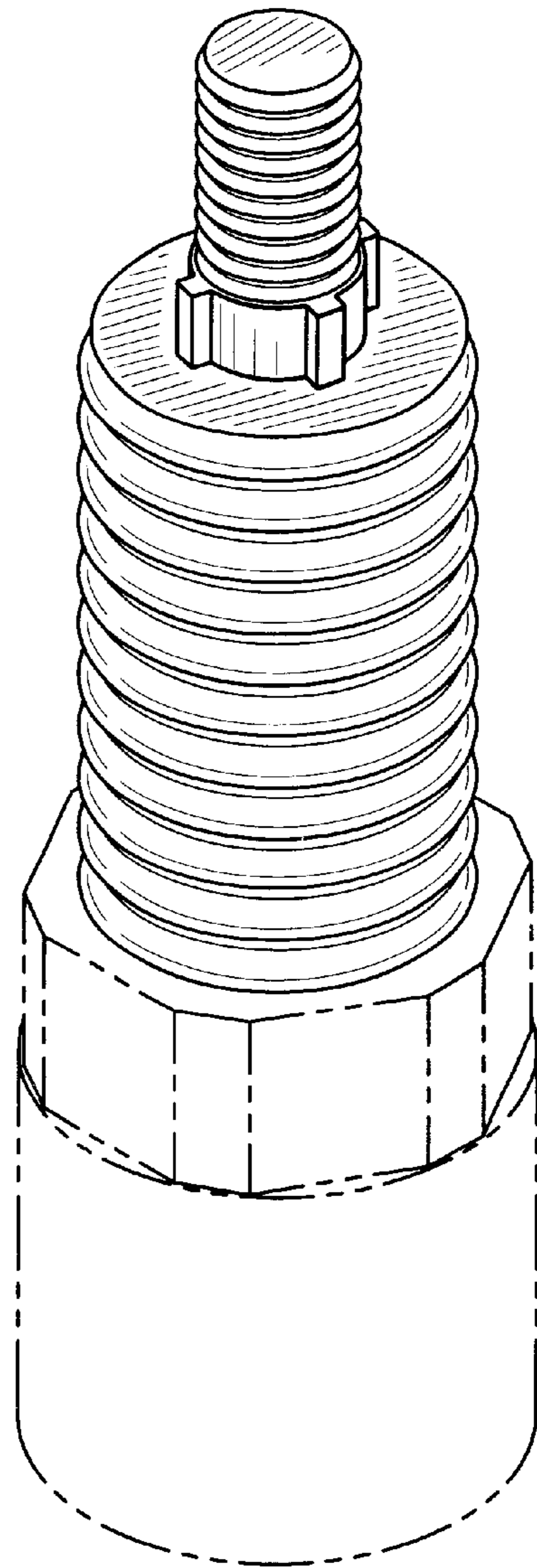

FIG. 2

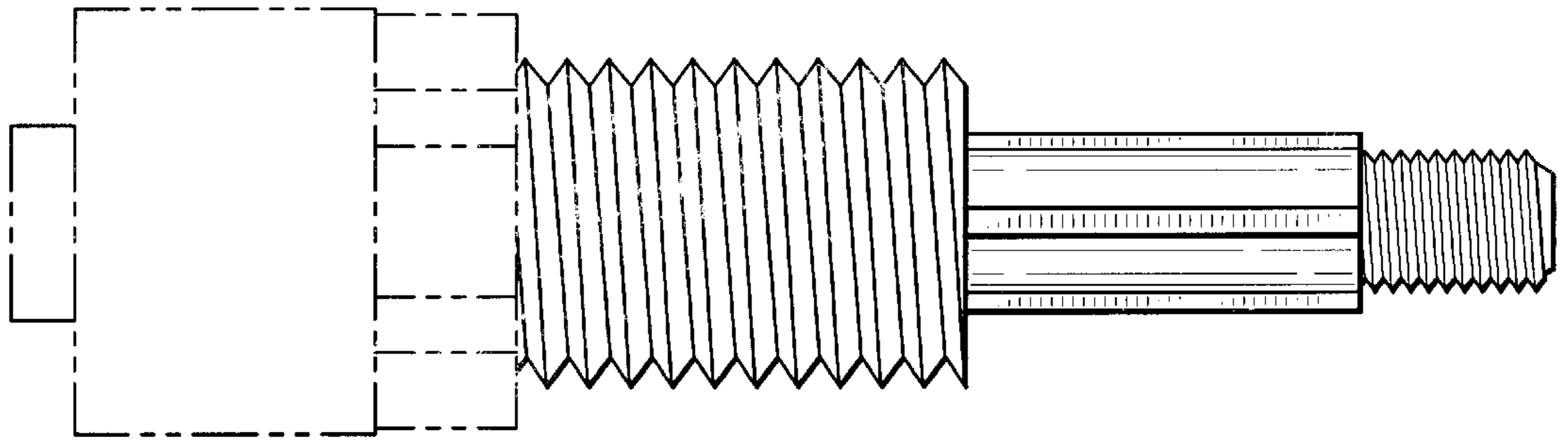

FIG. 3

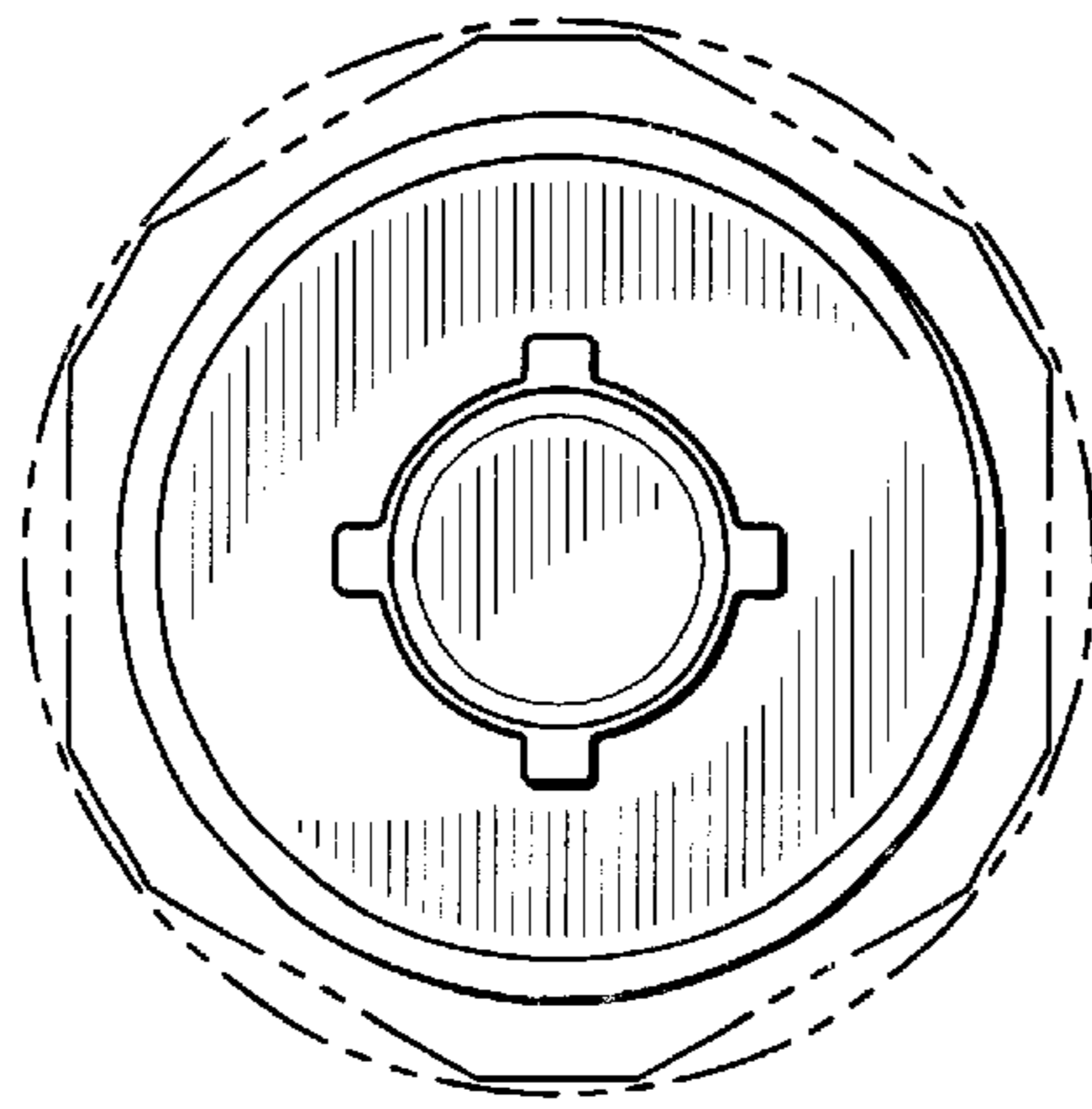

FIG. 4