



US00D482648S

(12) **United States Design Patent**
Eck et al.

(10) **Patent No.:** **US D482,648 S**

(45) **Date of Patent:** **** Nov. 25, 2003**

(54) **BOAT**

D409,555 S * 5/1999 Lapointe et al. D12/300

(75) Inventors: **Richard E. Eck**, Mount Vernon, IL (US); **David Kalhok**, Marion, IL (US)

* cited by examiner

(73) Assignee: **Bombardier Motor Corporation of America**, Grant, FL (US)

Primary Examiner—Lisa Lichtenstein

(74) *Attorney, Agent, or Firm*—Pillsbury Winthrop LLP

(**) Term: **14 Years**

(57) **CLAIM**

The ornamental design of a boat, as shown and described.

(21) Appl. No.: **29/145,864**

DESCRIPTION

(22) Filed: **Aug. 1, 2001**

FIG. 1 is a perspective illustration, from the right side, of the boat of our design;

(51) **LOC (7) Cl.** **12-06**

FIG. 2 is a top view thereof;

(52) **U.S. Cl.** **D12/300**

FIG. 3 is a right side view thereof, the left side view being a mirror image thereof;

(58) **Field of Search** D12/300-318;

114/56, 57, 363

FIG. 4 is a front view thereof;

(56) **References Cited**

FIG. 5 is a rear view thereof; and,

FIG. 6 is a bottom view thereof.

U.S. PATENT DOCUMENTS

D395,273 S * 6/1998 Maki et al. D12/314

1 Claim, 6 Drawing Sheets

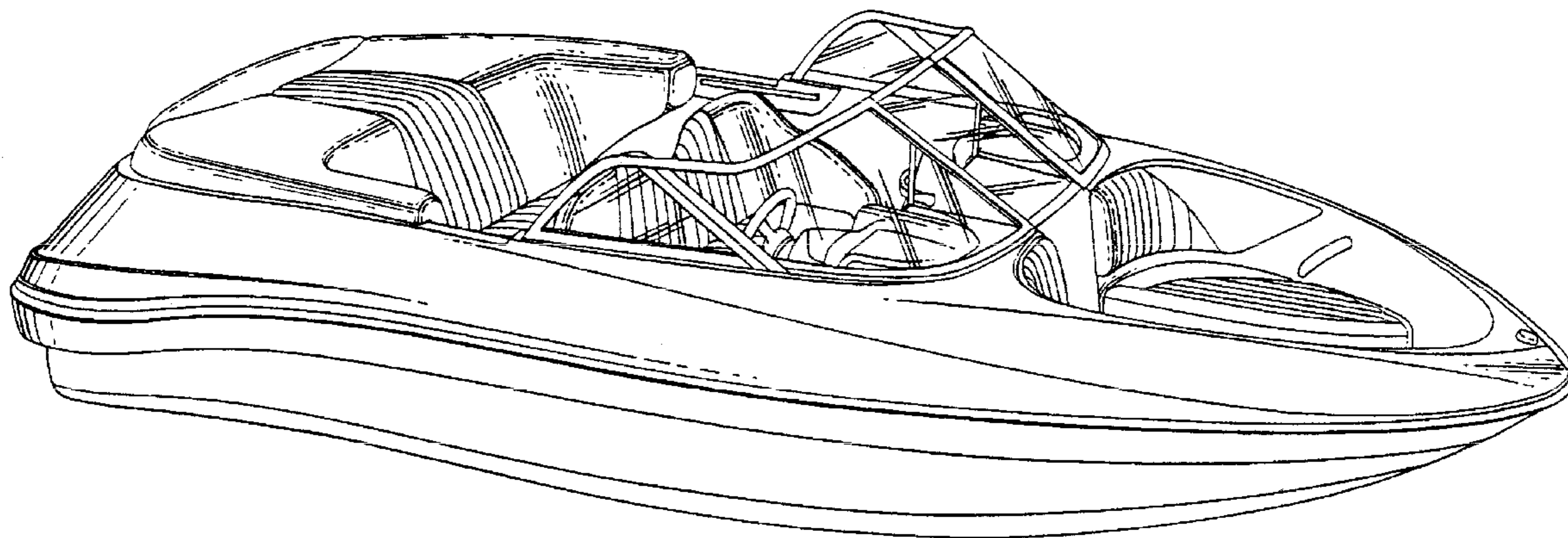

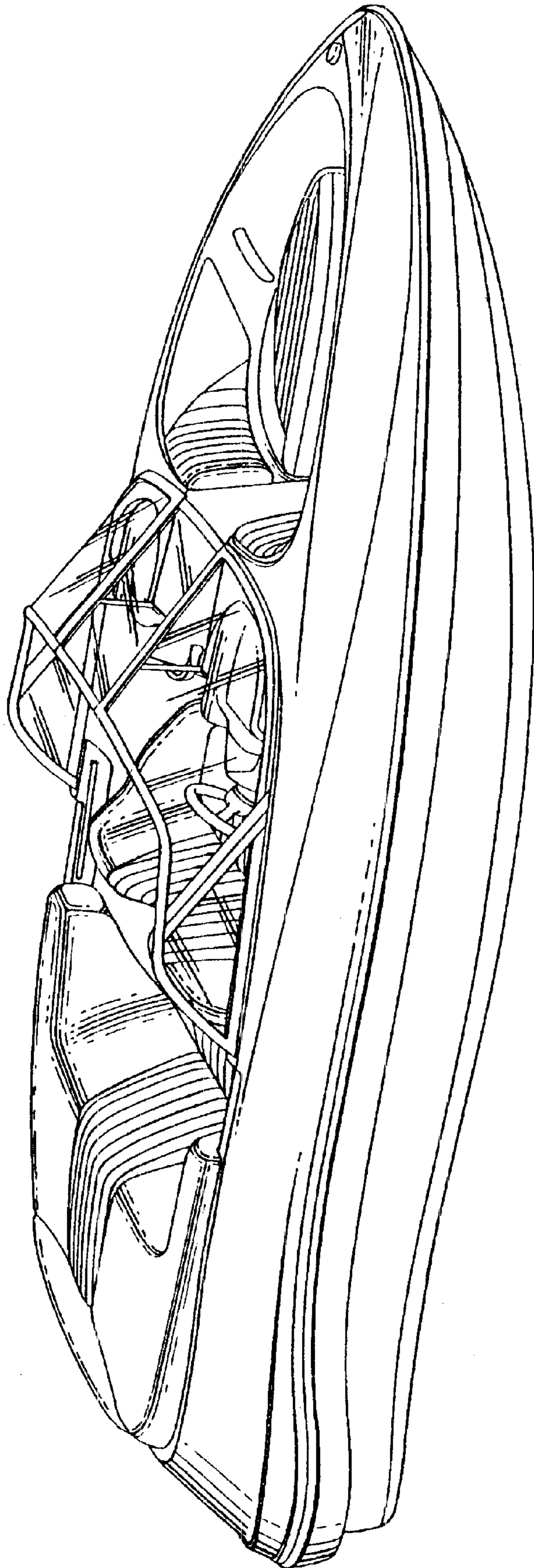

Fig. 1

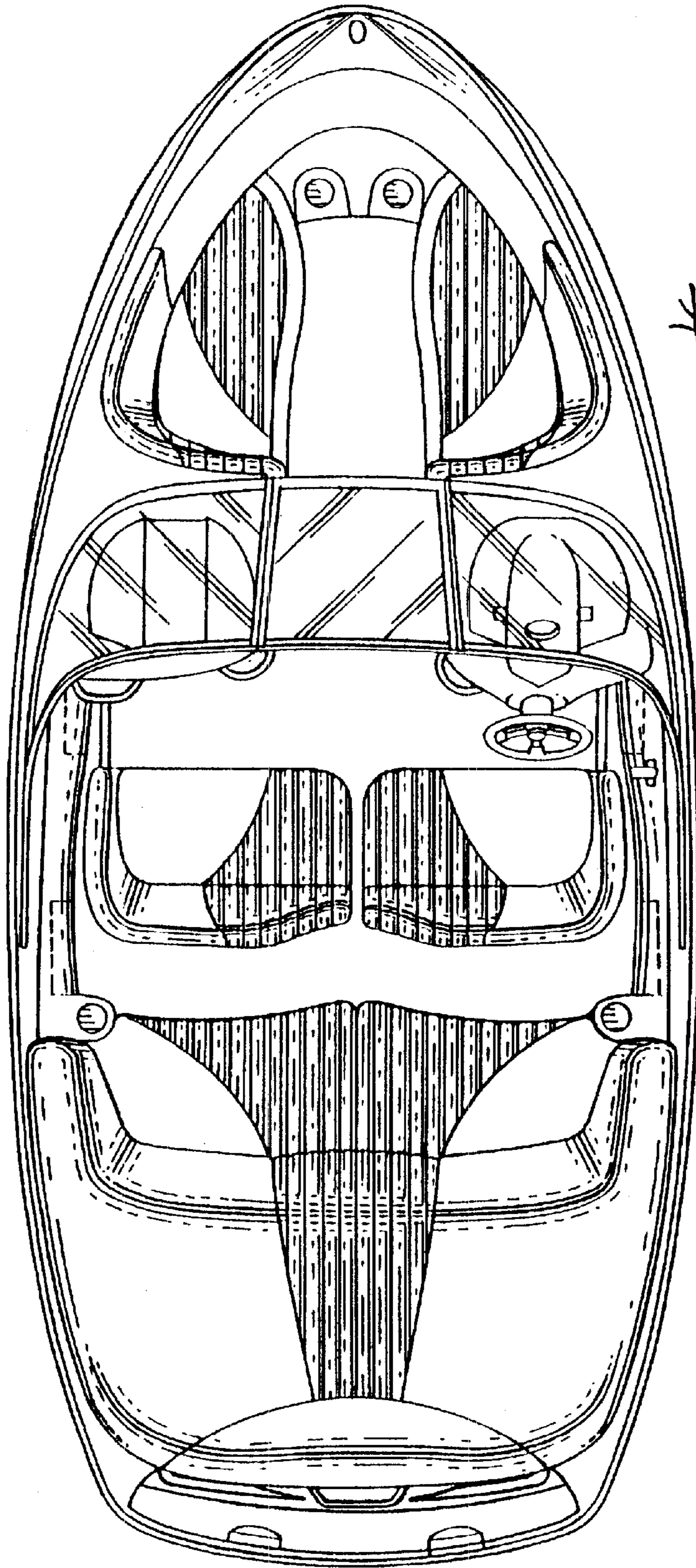

Fig. 2

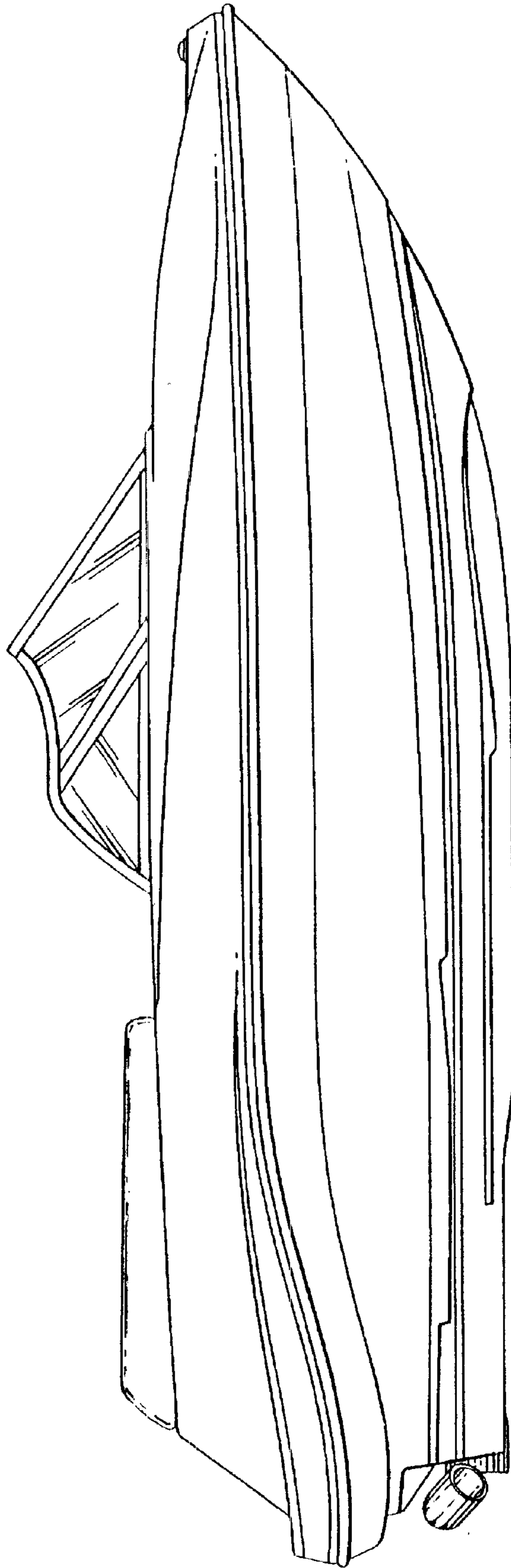

Fig. 3

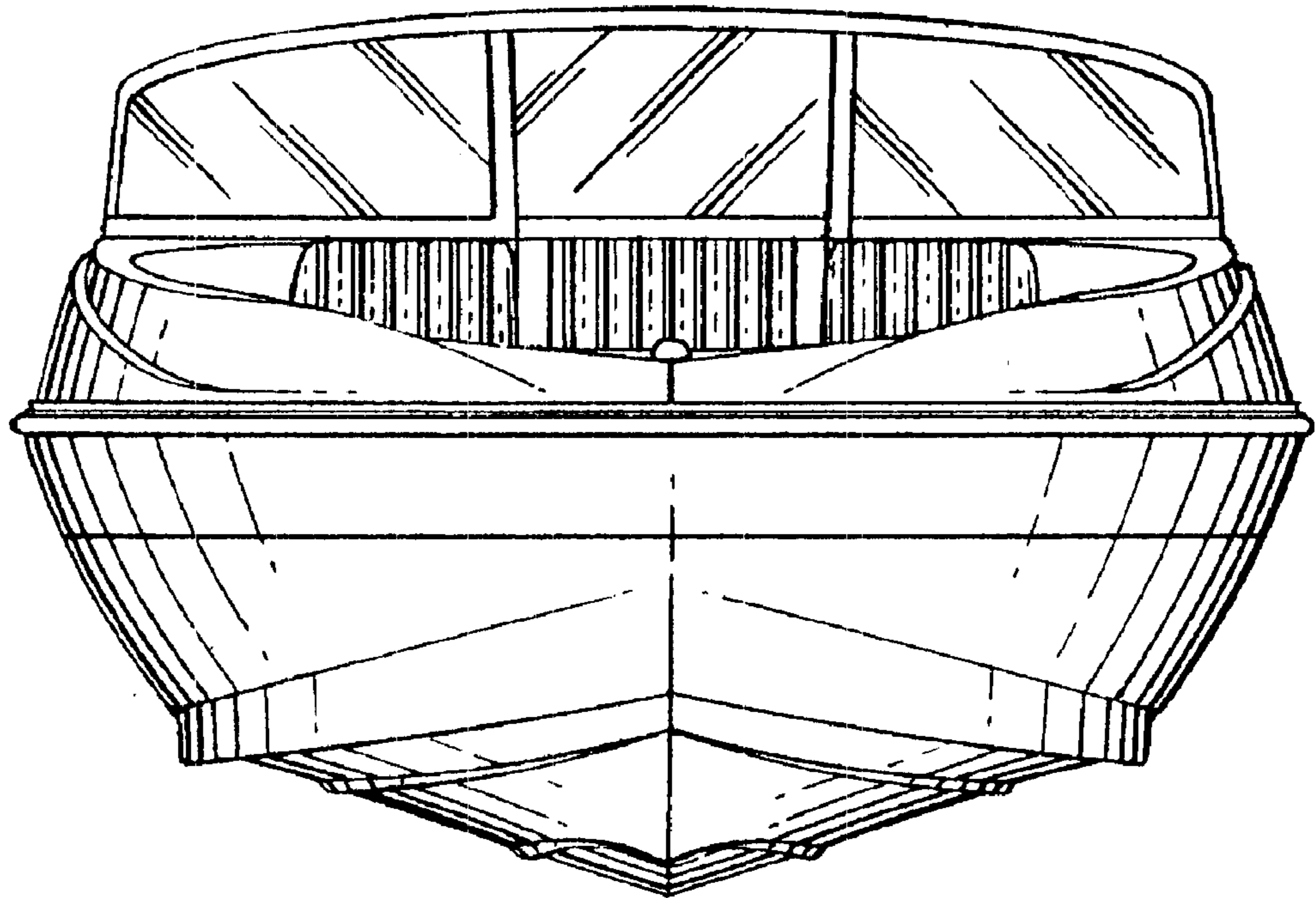

Fig. 4

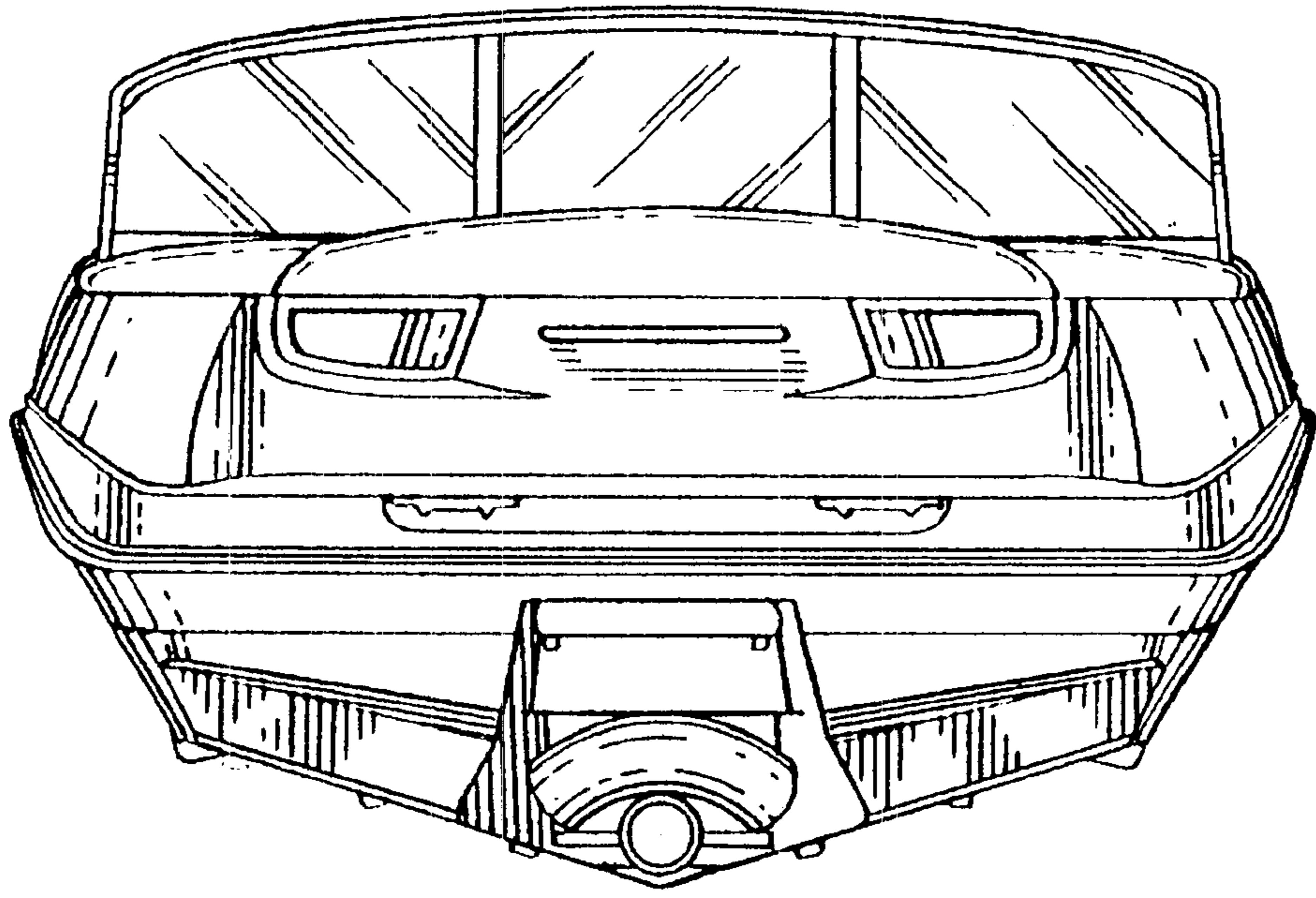

Fig. 5

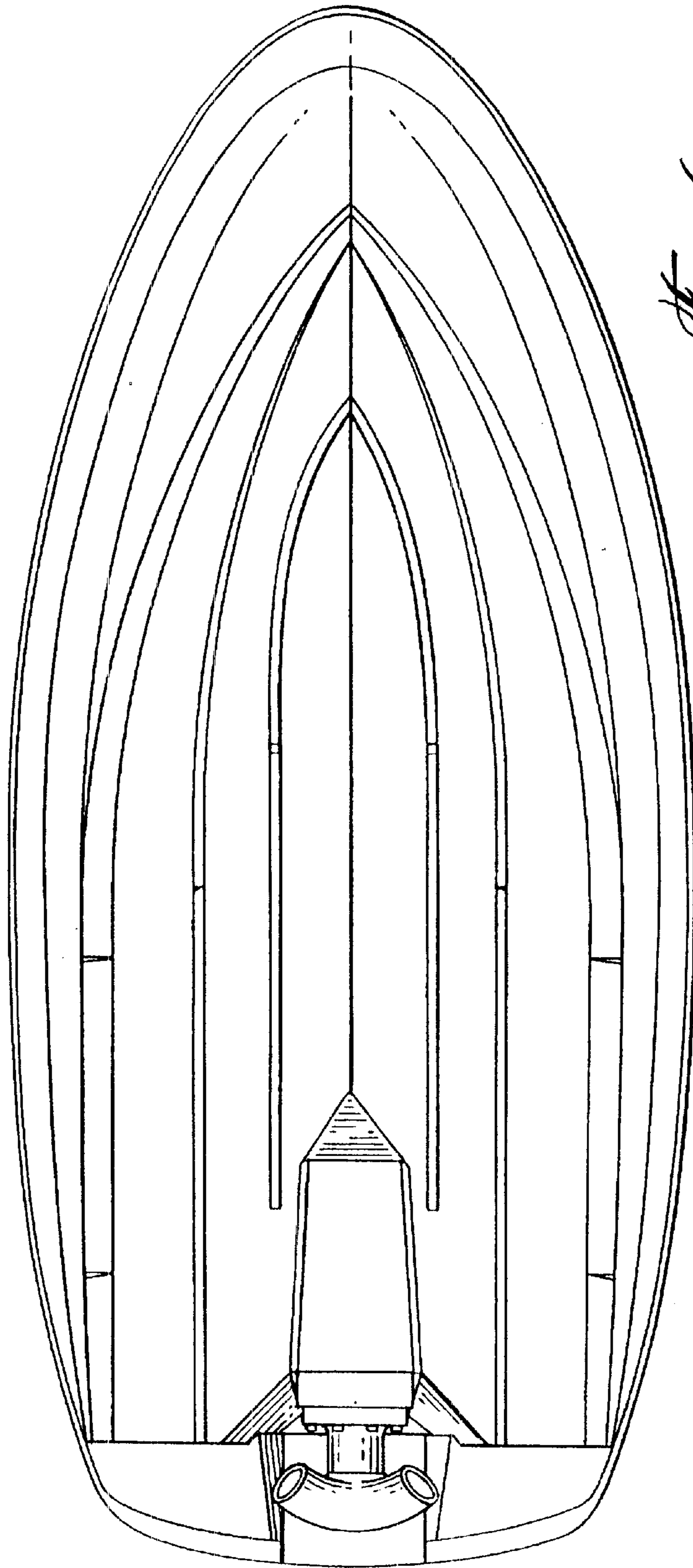

Fig. 6