



US00D482529S

(12) **United States Design Patent**
Hardigg et al.

(10) **Patent No.:** **US D482,529 S**

(45) **Date of Patent:** **** Nov. 25, 2003**

(54) **TRANSPORT CASE**

(75) Inventors: **James S. Hardigg**, Conway, MA (US);
Mark C. Gaydos, Greenfield, MA
(US); **Stanley Lewandowski**, Shelburne
Falls, MA (US)

(73) Assignee: **Hardigg Industries, Inc.**, South
Deerfield, MA (US)

(**) Term: **14 Years**

(21) Appl. No.: **29/175,896**

(22) Filed: **Feb. 12, 2003**

(51) **LOC (7) Cl.** **03-01**

(52) **U.S. Cl.** **D3/276**

(58) **Field of Search** D3/272, 273, 276,
D3/279, 282, 294, 281; 206/349, 372, 373;
190/18 A, 100, 110, 111, 113

(56) **References Cited**

U.S. PATENT DOCUMENTS

D335,030 S * 4/1993 Alfonso D3/279
D432,304 S * 10/2000 Zurwelle et al. D3/281
D438,004 S * 2/2001 Watson et al. D3/276

D439,407 S * 3/2001 Parker D3/276
D441,954 S * 5/2001 Parker D3/279
D462,519 S * 9/2002 Gaydos et al. D3/276
D467,424 S * 12/2002 Hardigg et al. D3/279
D467,425 S * 12/2002 Hardigg et al. D3/279
D467,426 S * 12/2002 Hardigg et al. D3/279

* cited by examiner

Primary Examiner—Philip S. Hyder

(74) *Attorney, Agent, or Firm*—McCormick, Paulding &
Huber LLP

(57) **CLAIM**

The ornamental design for a transport case, as shown and
described.

DESCRIPTION

FIG. 1 is a top left perspective view of the transport case
showing our new design;
FIG. 2 is a top plan view of the case of FIG. 1;
FIG. 3 is a rear elevation view of the case of FIG. 1;
FIG. 4 is a left end view of the case of FIG. 1;
FIG. 5 is a right end view of the case of FIG. 1;
FIG. 6 is a front elevation view of the case of FIG. 1; and,
FIG. 7 is a bottom plan view of the case of FIG. 1.

1 Claim, 6 Drawing Sheets

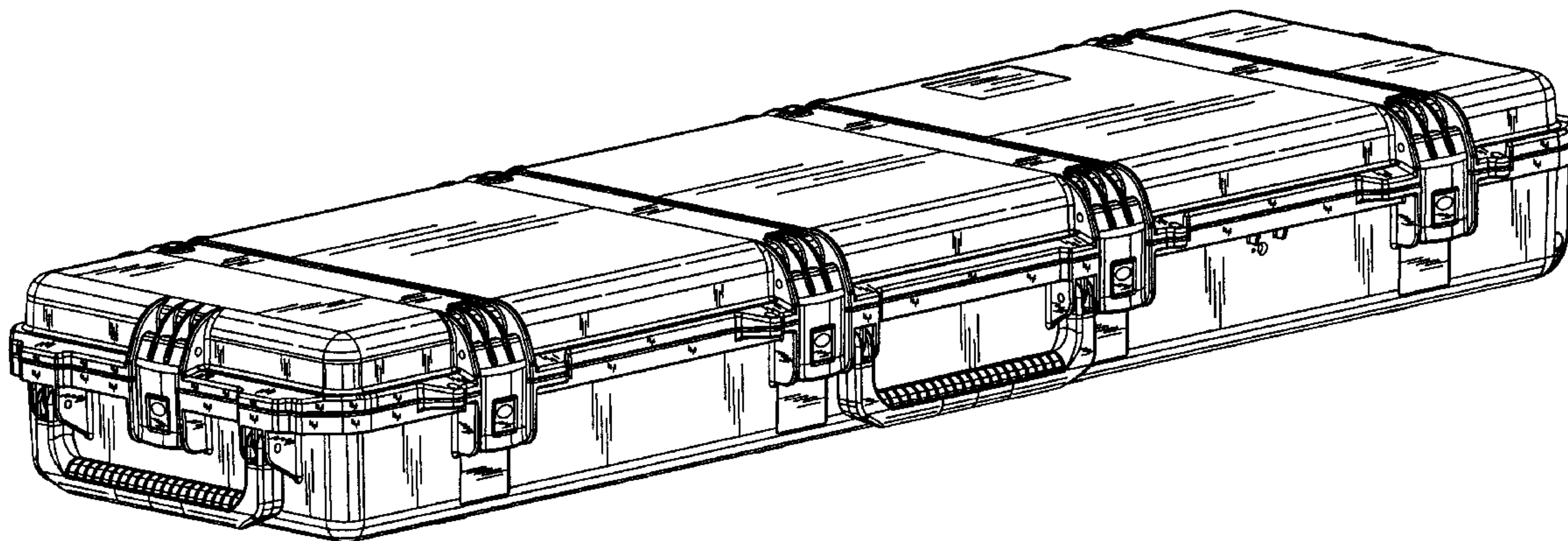

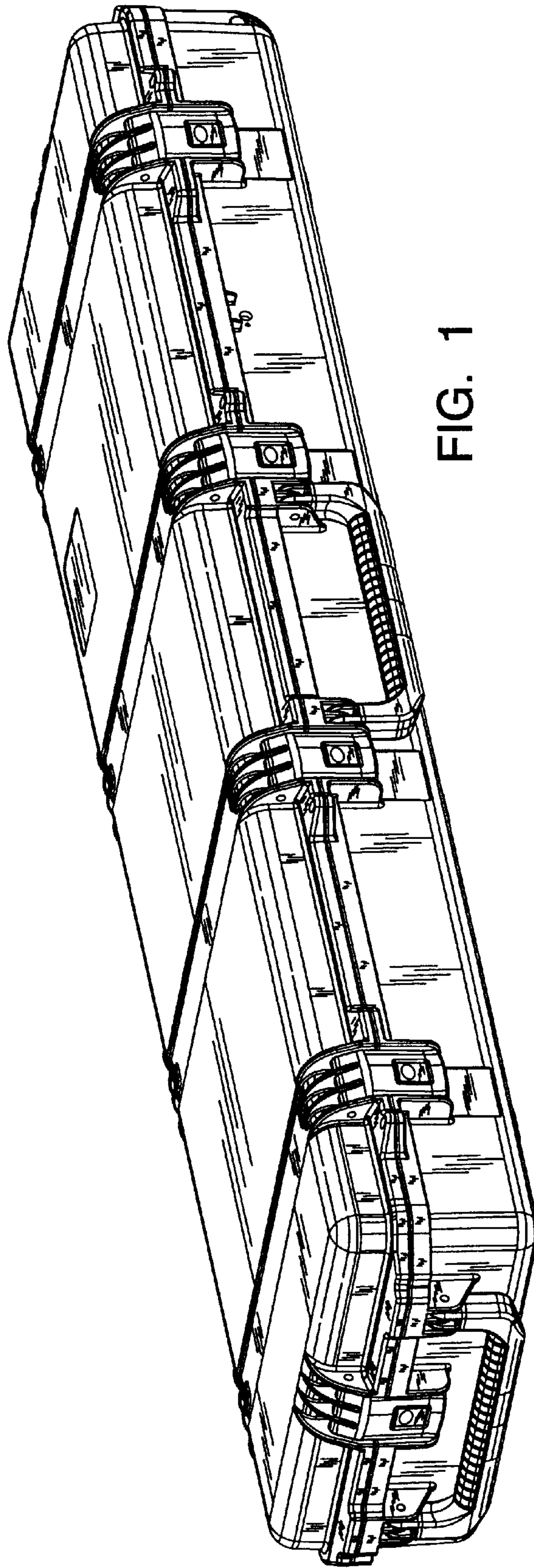

FIG. 1

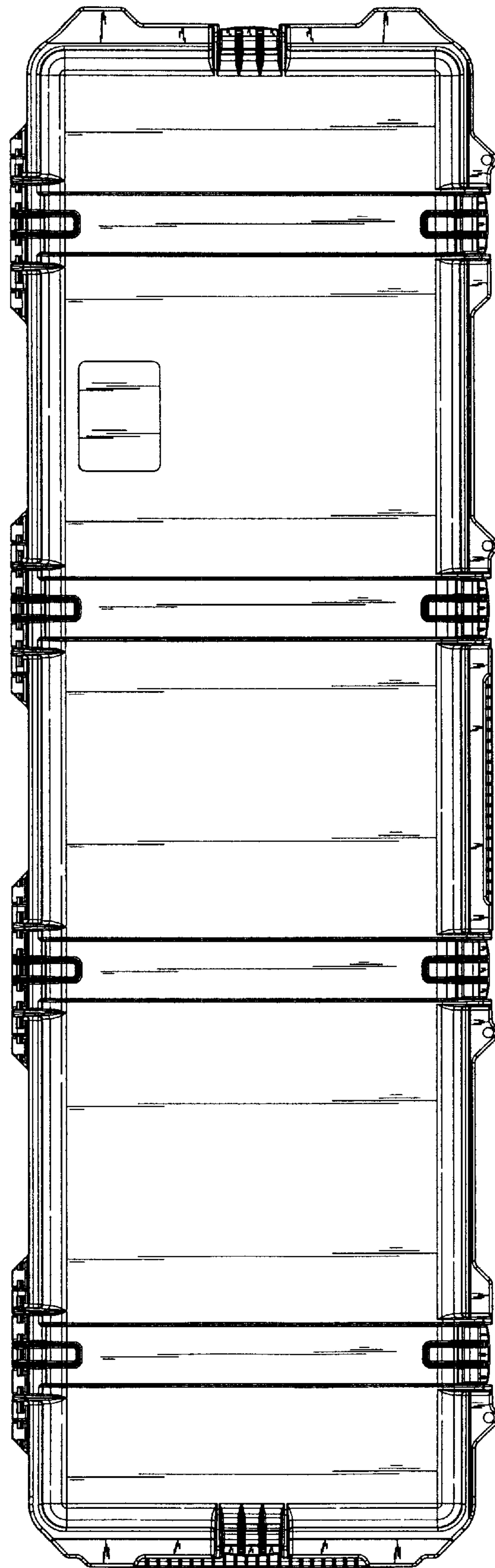

FIG. 2

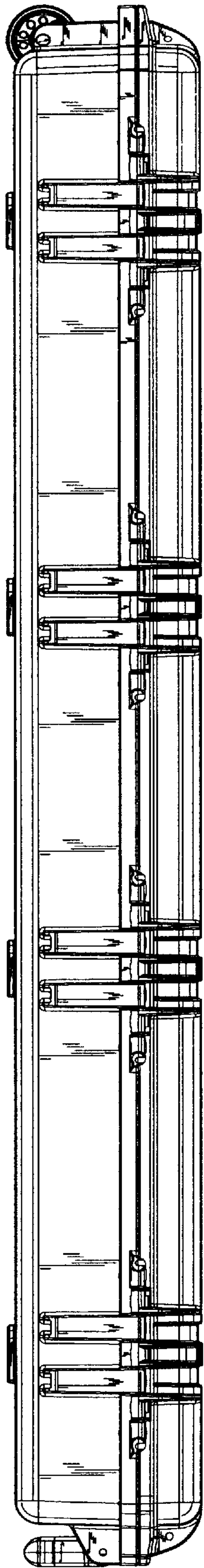

FIG. 3

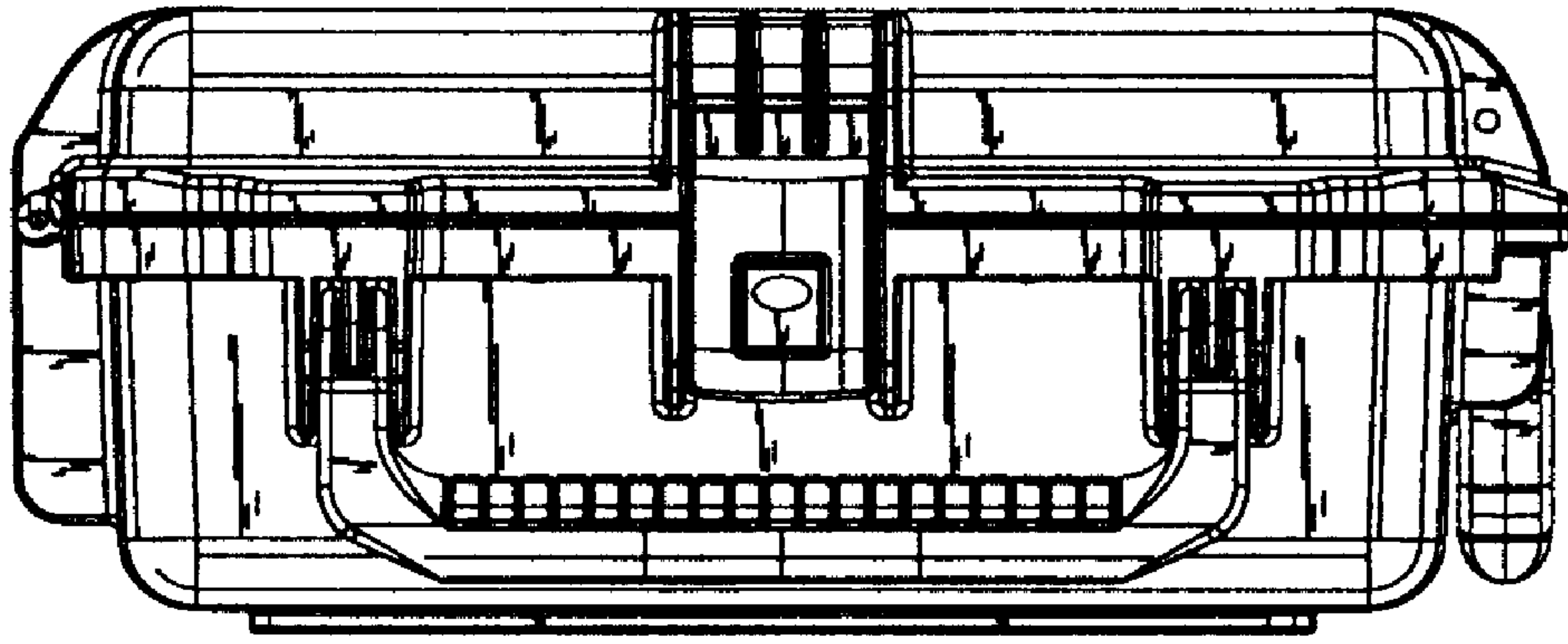

FIG. 4

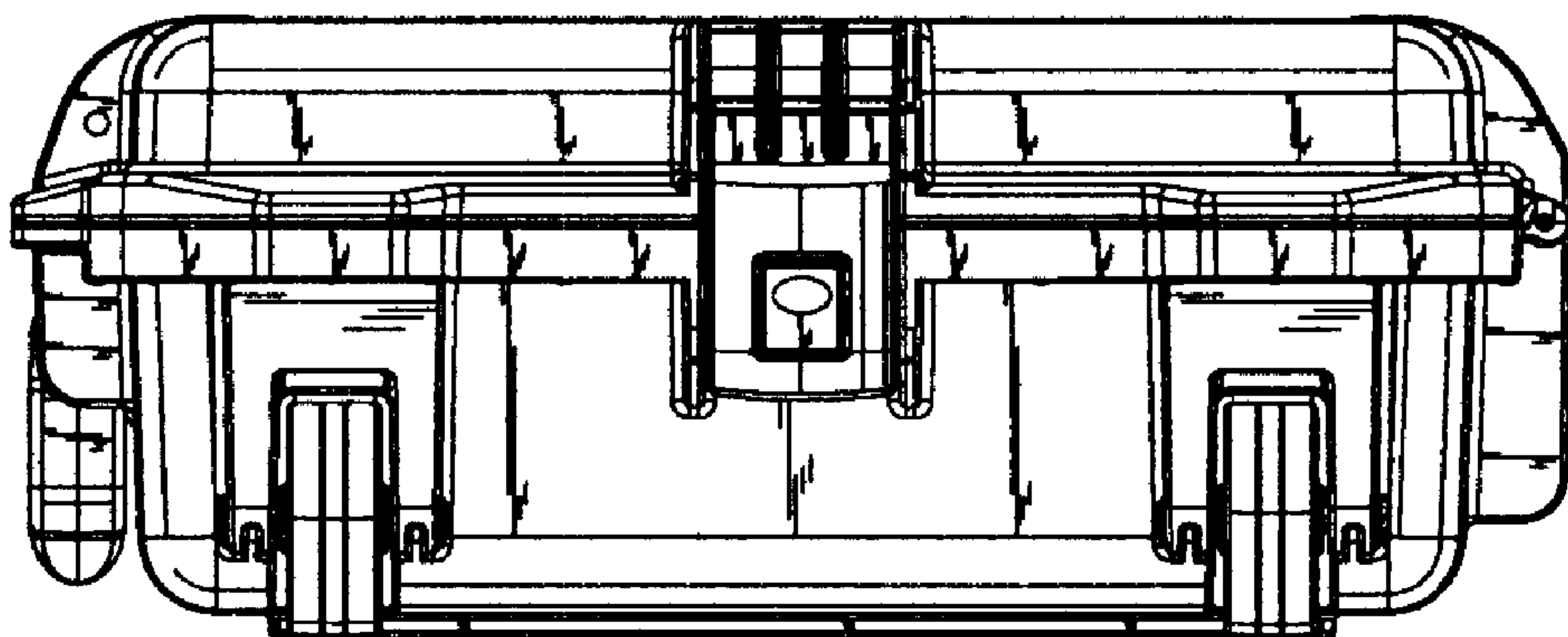

FIG. 5

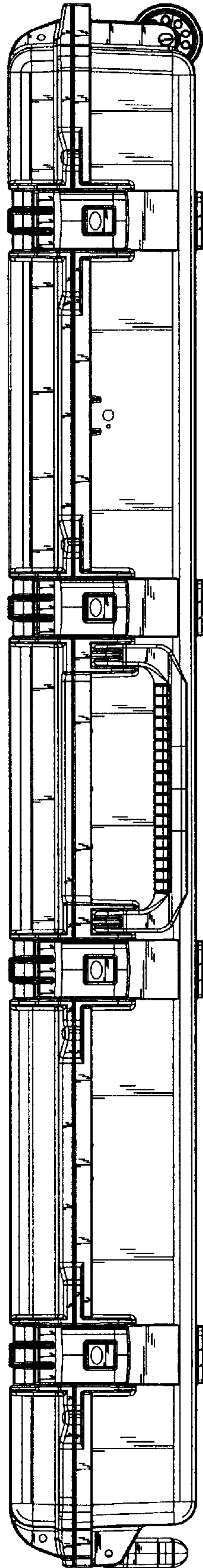

FIG. 6

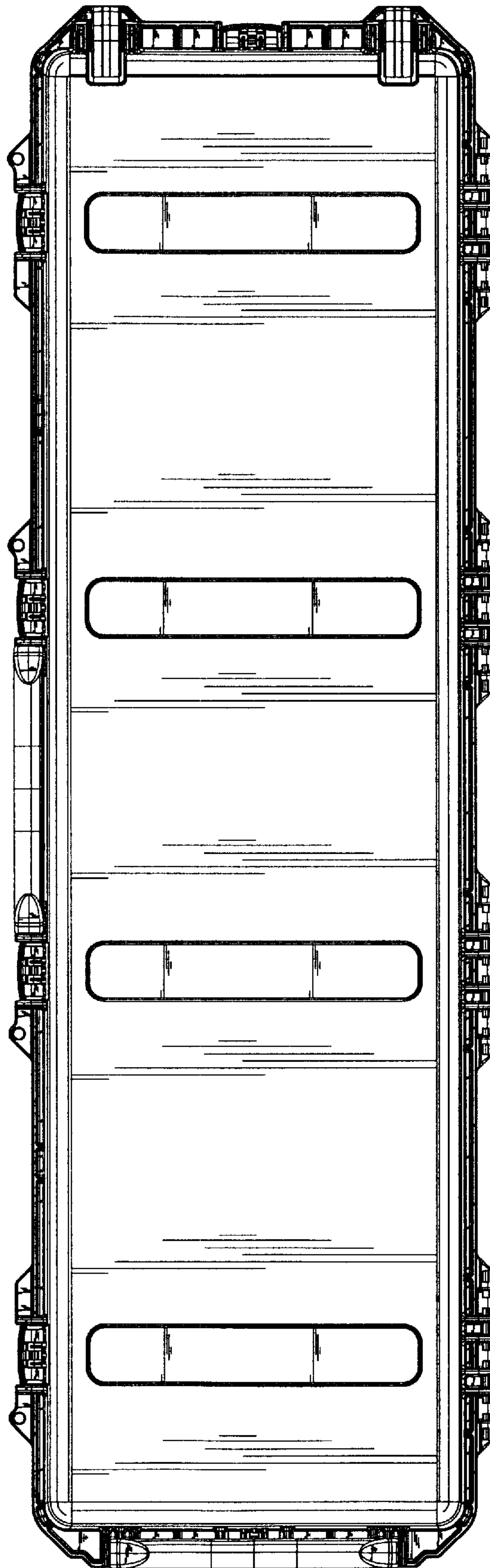

FIG. 7