



US00D482302S

(12) **United States Design Patent**
Dozier et al.

(10) **Patent No.:** **US D482,302 S**

(45) **Date of Patent:** **** Nov. 18, 2003**

(54) **BUMPER FOR A TRUCK VEHICLE**

(75) Inventors: **C. Michael Dozier**, Carrollton, TX (US); **Rob A. Cook**, Dutton, MT (US); **John H. Waskow**, Keller, TX (US); **Eric N. Tucker**, Denton, TX (US); **Joseph F. Marrs**, Aubrey, TX (US)

(73) Assignee: **PACCAR INC**, Bellevue, WA (US)

(**) Term: **14 Years**

(21) Appl. No.: **29/157,169**

(22) Filed: **Mar. 13, 2002**

(51) **LOC (7) Cl.** **12-16**

(52) **U.S. Cl.** **D12/169**

(58) **Field of Search** D12/169, 196,
D12/172; 293/112, 113, 115, 120; 296/180.1,
180.2

(56) **References Cited**

U.S. PATENT DOCUMENTS

D423,429 S * 4/2000 Hickman et al. D12/169
D445,073 S * 7/2001 Tirey et al. D12/169
D445,361 S * 7/2001 Tirey et al. D12/96

* cited by examiner

Primary Examiner—Melody N. Brown

(74) *Attorney, Agent, or Firm*—Sidley Austin Brown & Wood LLP

(57) **CLAIM**

The ornamental design for a bumper for a truck vehicle, as shown and described.

DESCRIPTION

FIG. 1 is a perspective view of a bumper for a truck vehicle showing a first embodiment of our new design;

FIG. 2 is a second perspective view thereof;

FIG. 3 is a front view thereof;

FIG. 4 is a side view thereof;

FIG. 5 is an opposite side view thereof;

FIG. 6 is a rear view thereof;

FIG. 7 is a top view thereof;

FIG. 8 is a bottom view thereof;

FIG. 9 is a third perspective view thereof;

FIG. 10 is a perspective view of a bumper for a truck vehicle according to a second embodiment of our novel design which is identical to that shown in FIGS. 1–7 except it includes an air dam as shown;

FIG. 11 is a second perspective view of said second embodiment;

FIG. 12 is a front view of said second embodiment;

FIG. 13 is a side view of said second embodiment;

FIG. 14 is an opposite side view of said second embodiment;

FIG. 15 is a rear view of said second embodiment;

FIG. 16 is a top view of said second embodiment;

FIG. 17 is a bottom view of said second embodiment; and,

FIG. 18 is a third perspective view of said second embodiment.

Parts shown in broken lines are for illustrative purposes only and form no part of the claimed design.

1 Claim, 8 Drawing Sheets

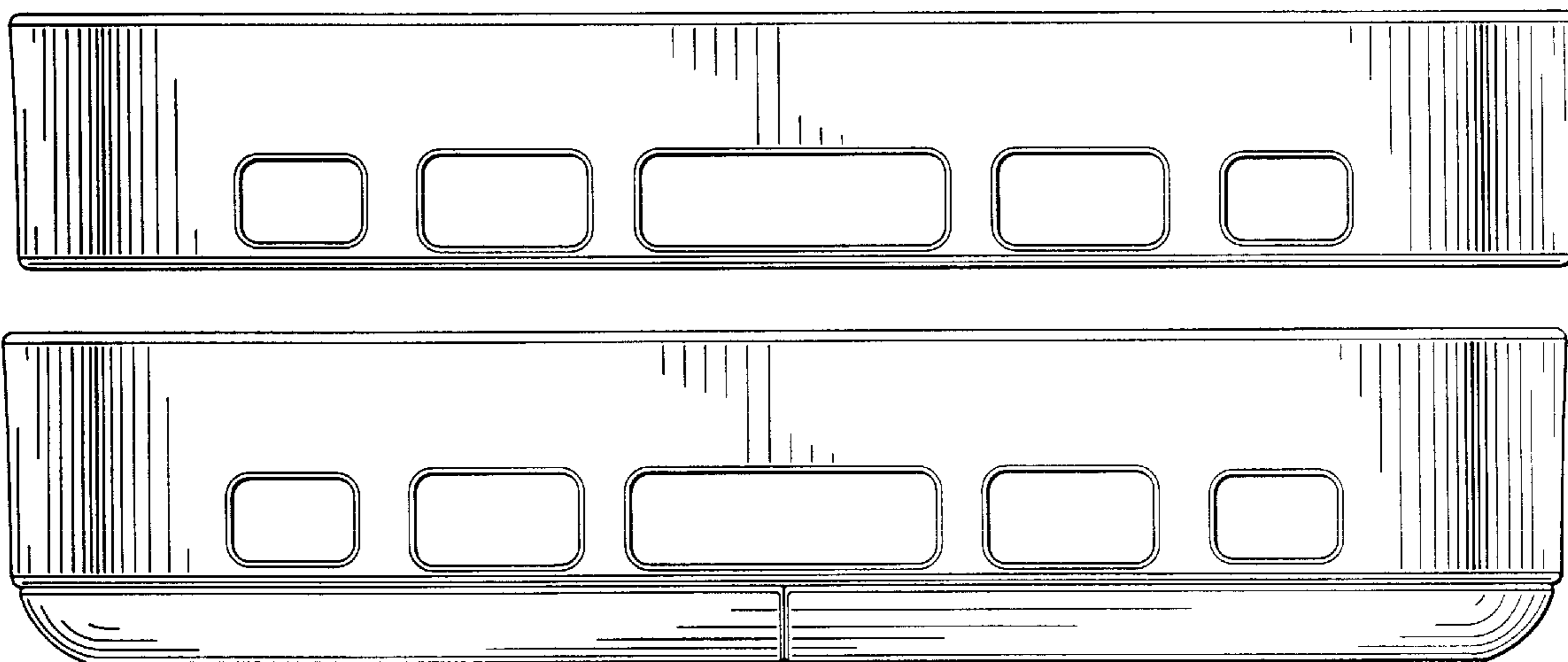

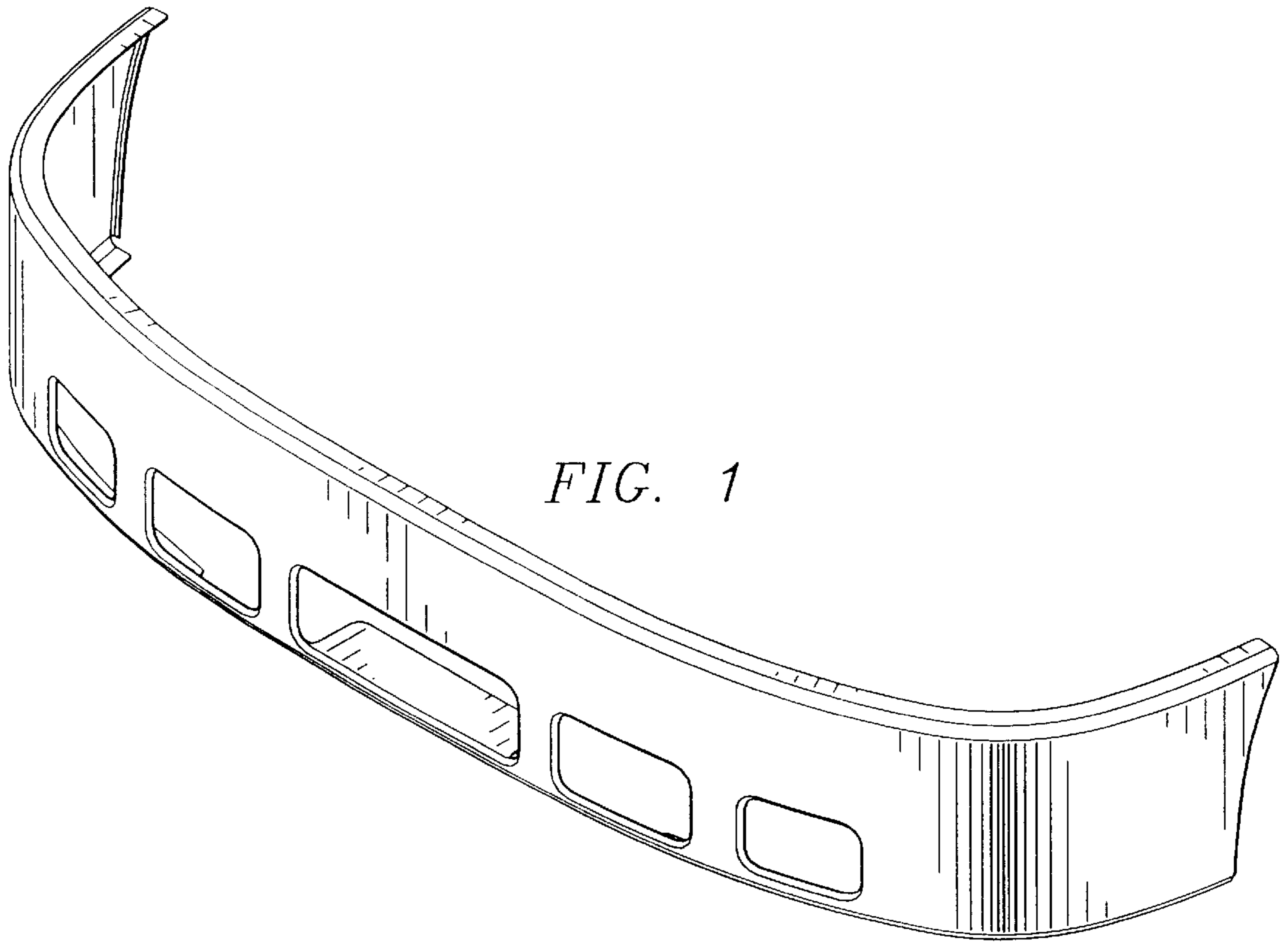

FIG. 1

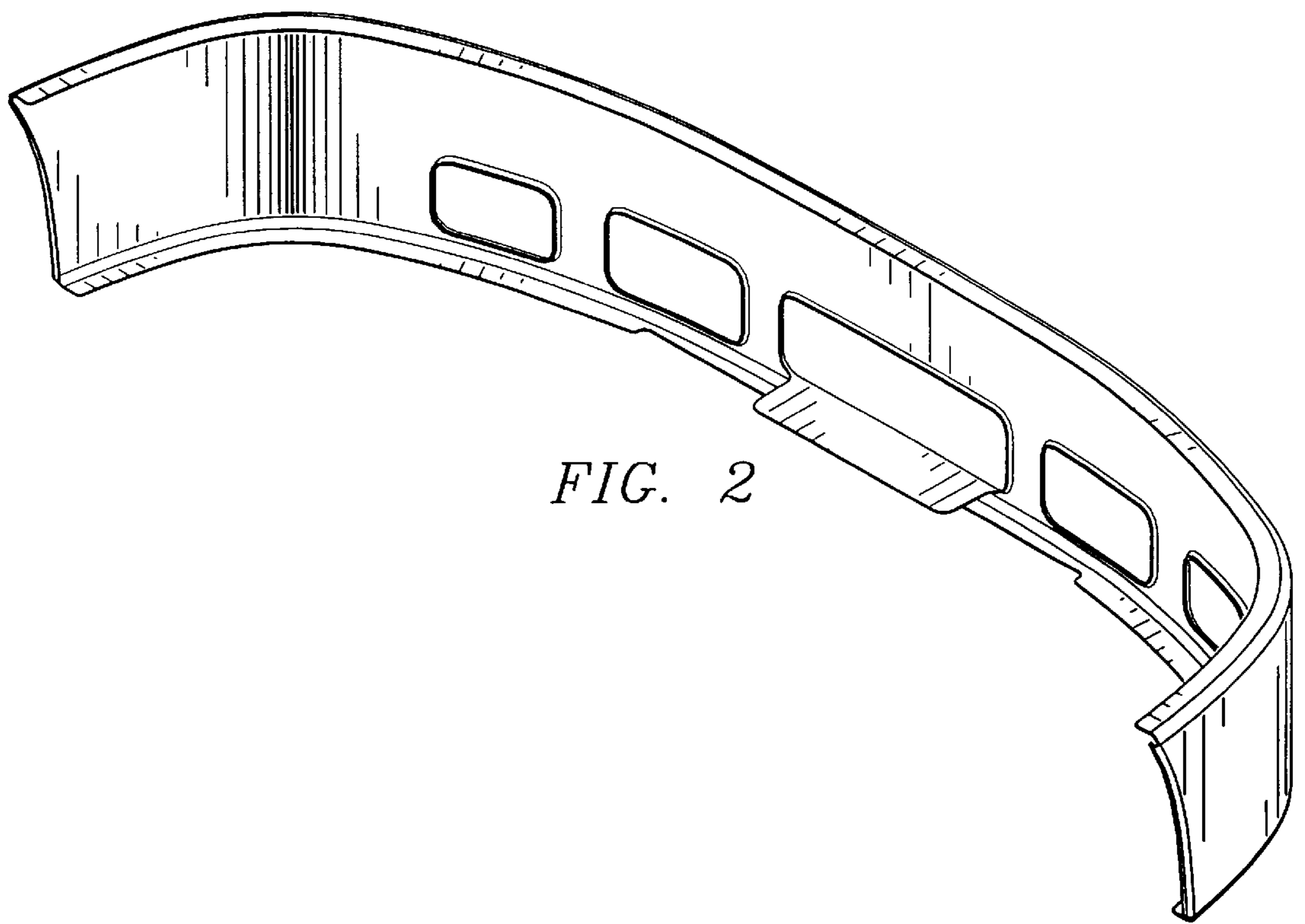

FIG. 2

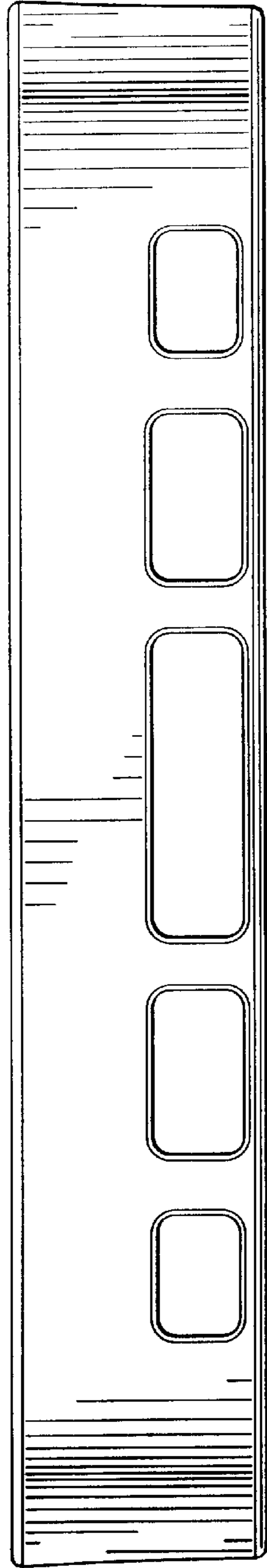

FIG. 3

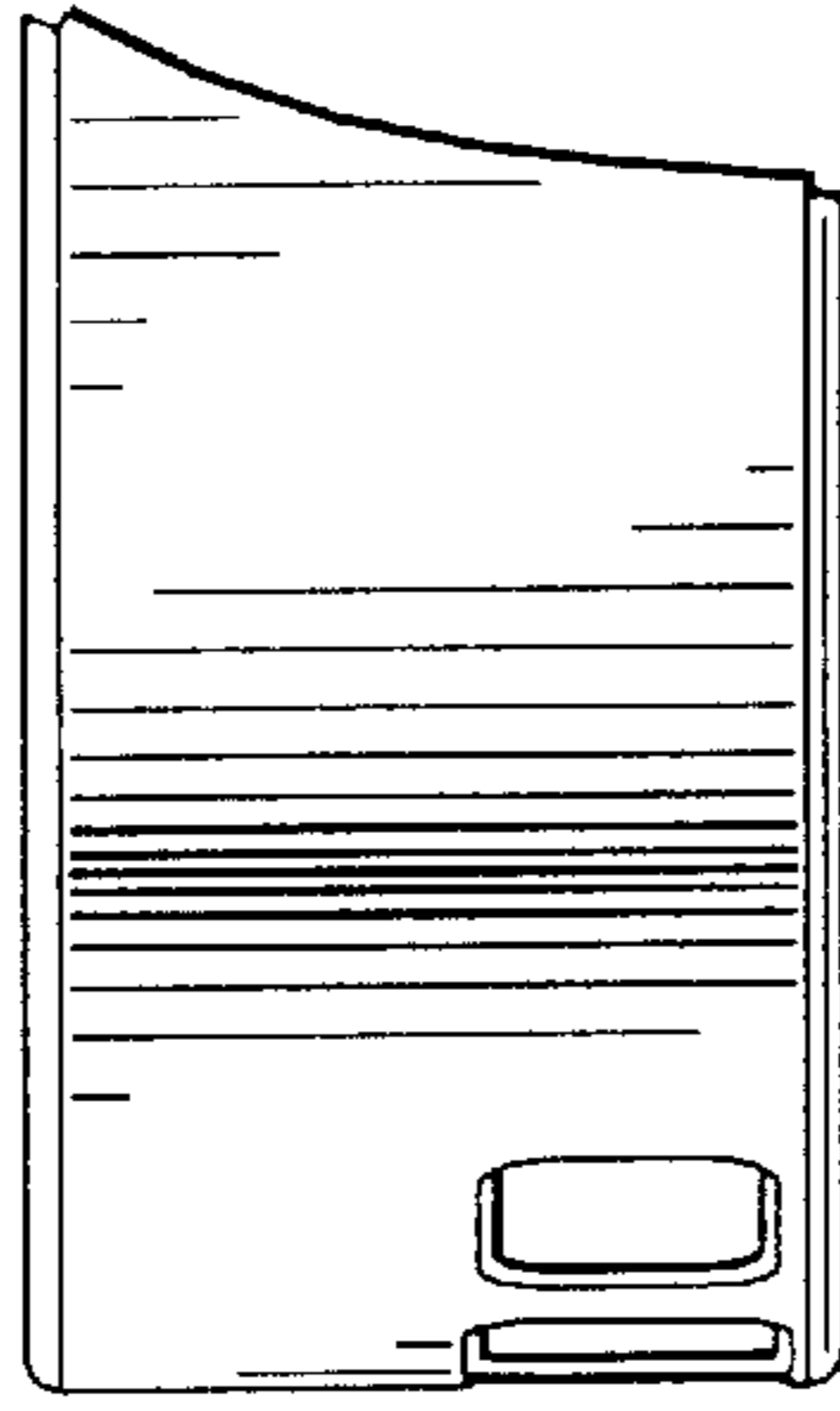

FIG. 5

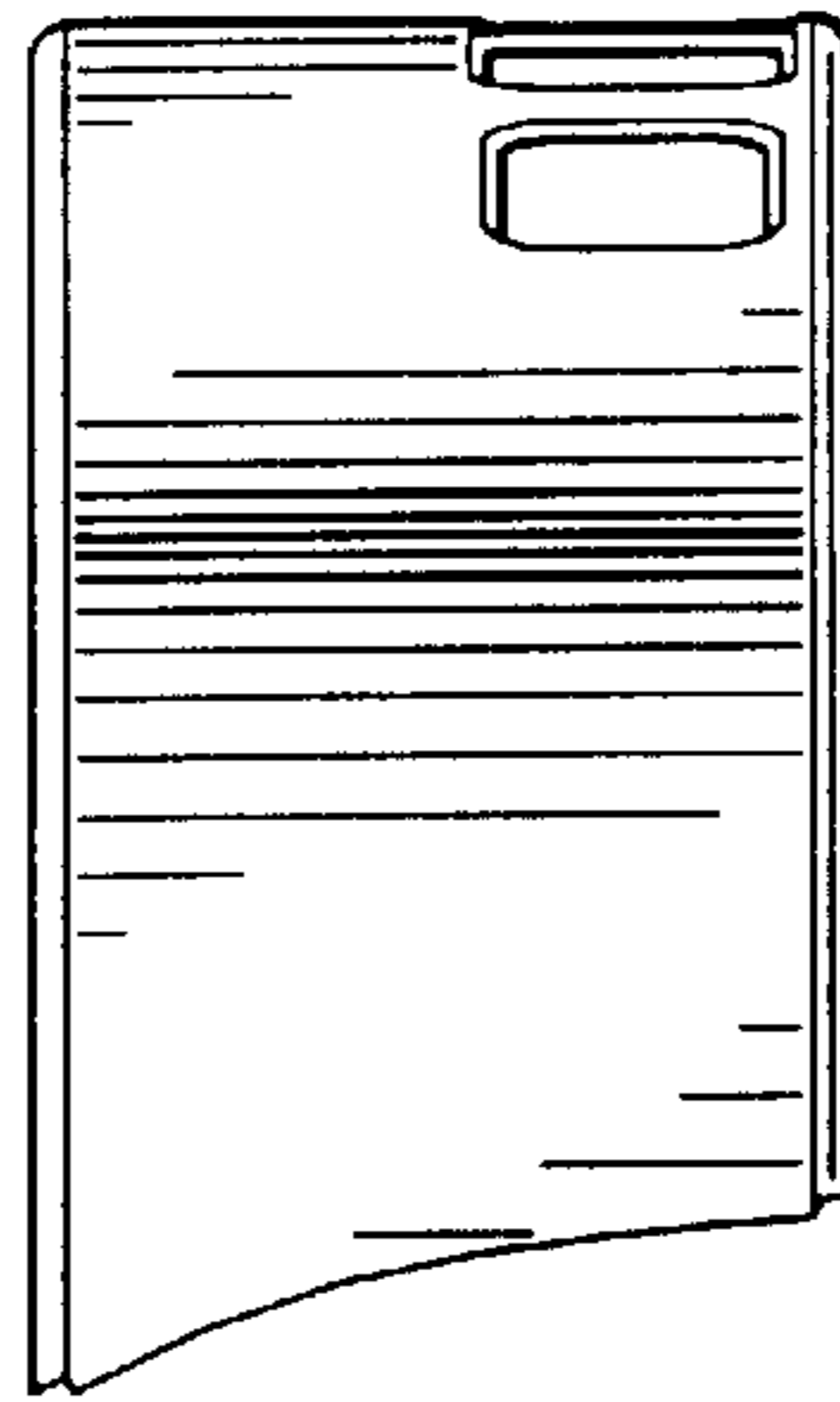

FIG. 4

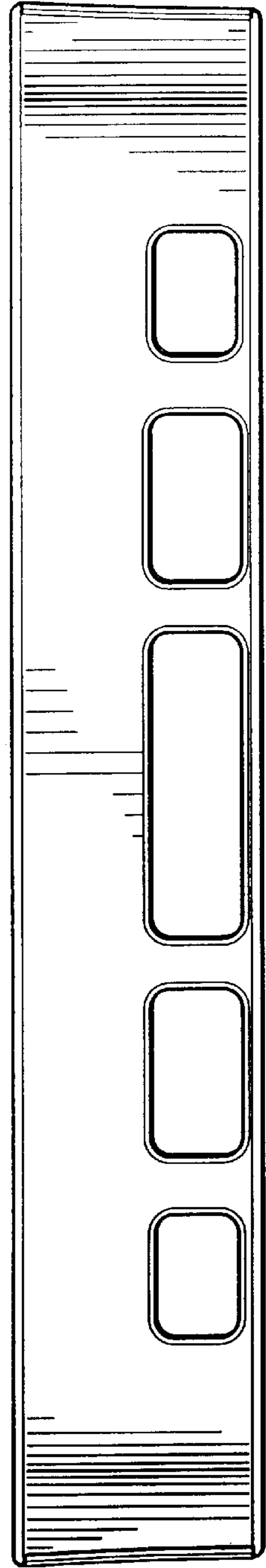

FIG. 6

FIG. 7

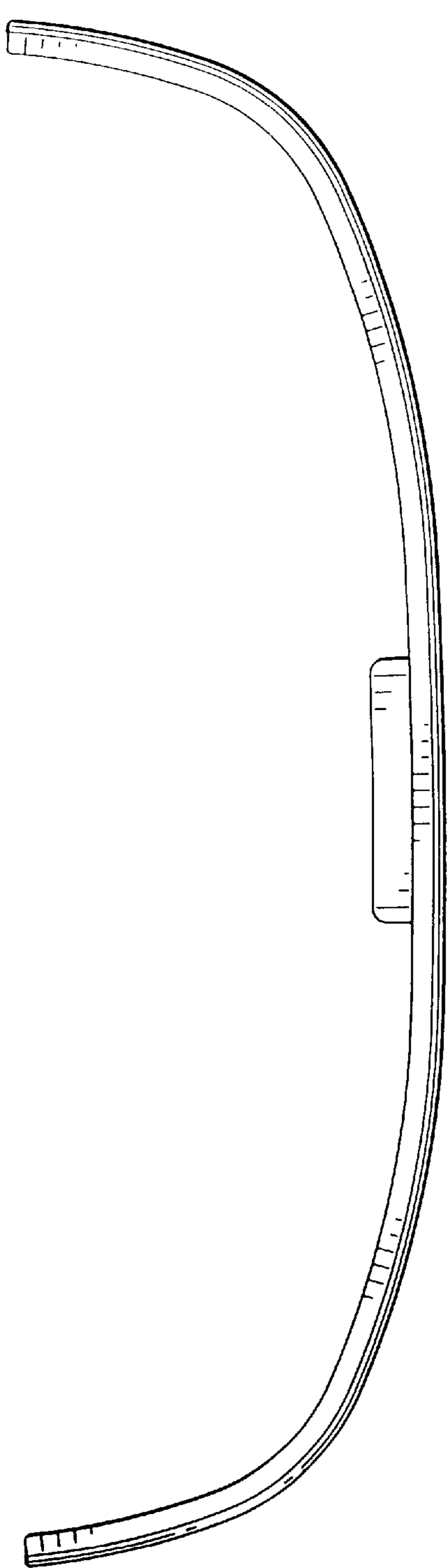
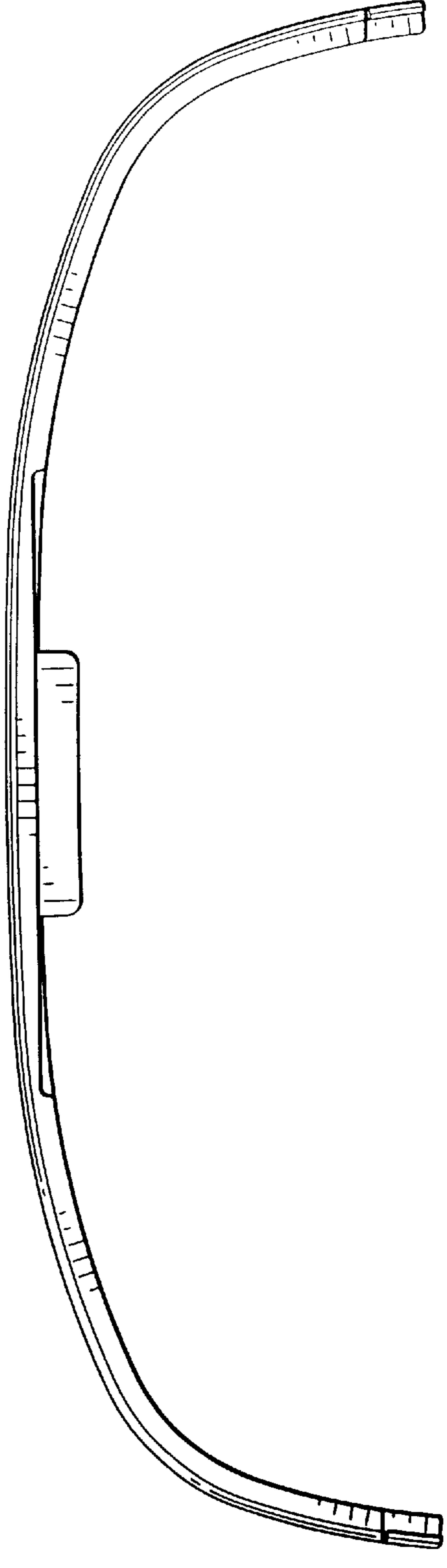

FIG. 8



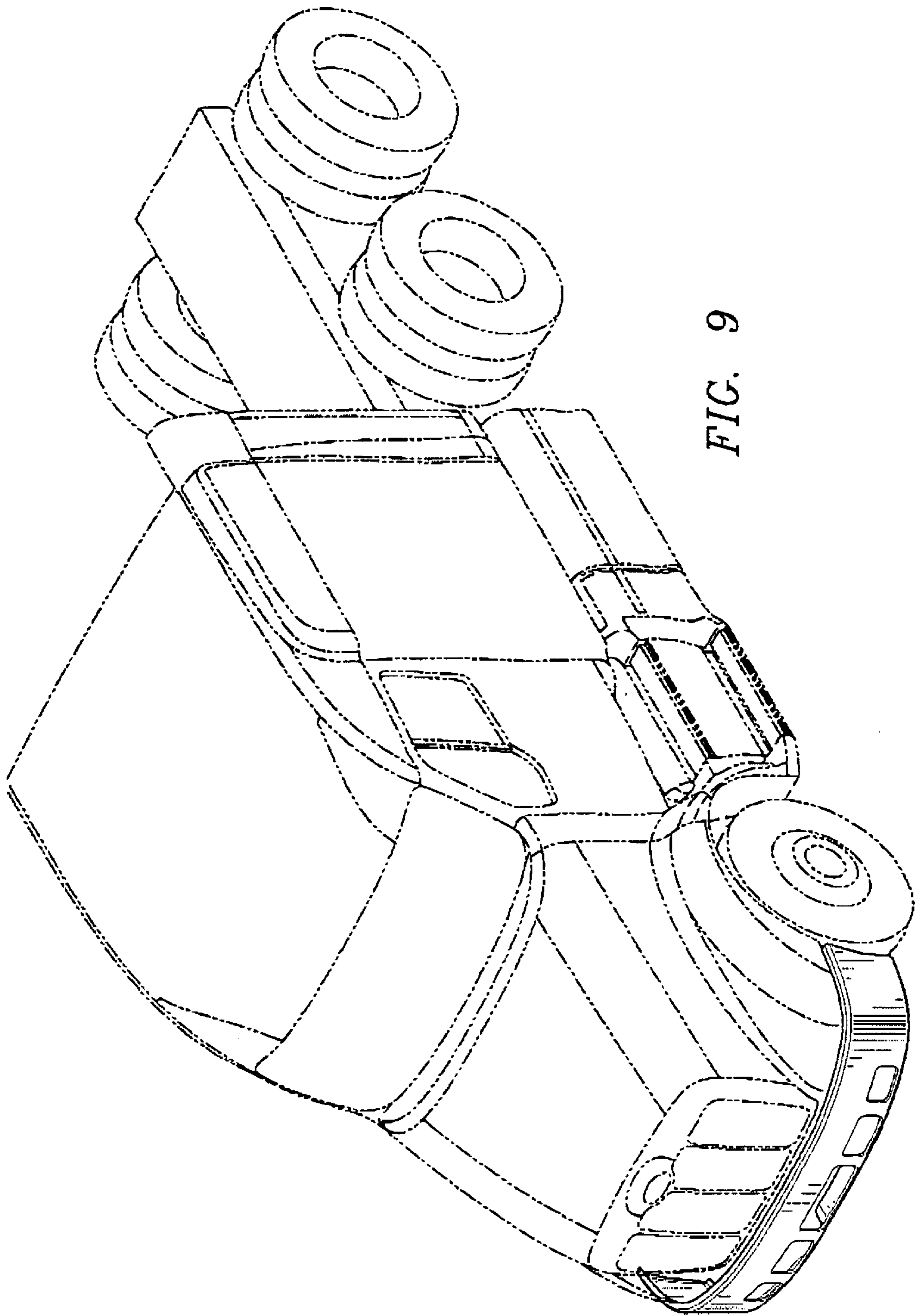

FIG. 9

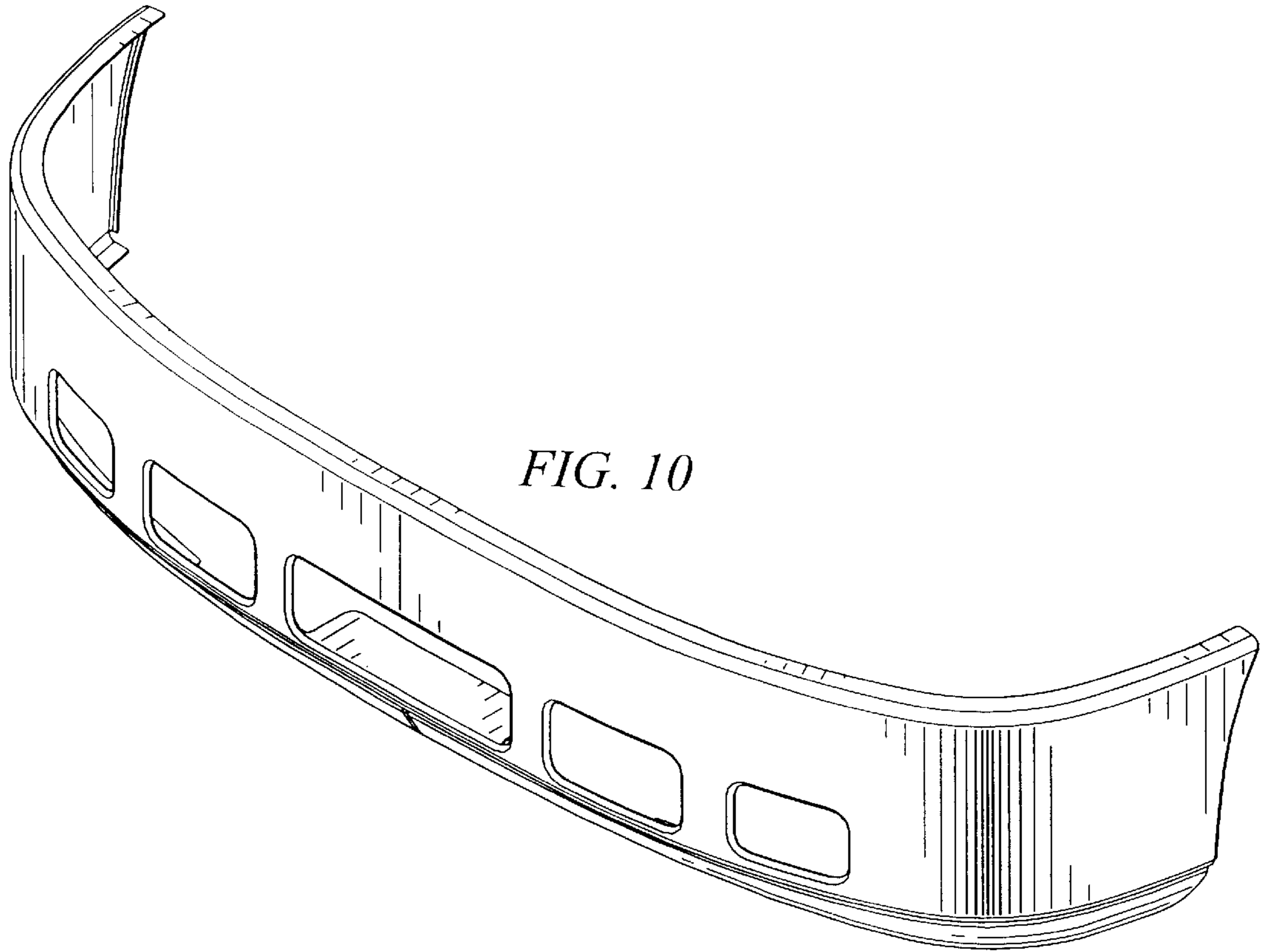

FIG. 10

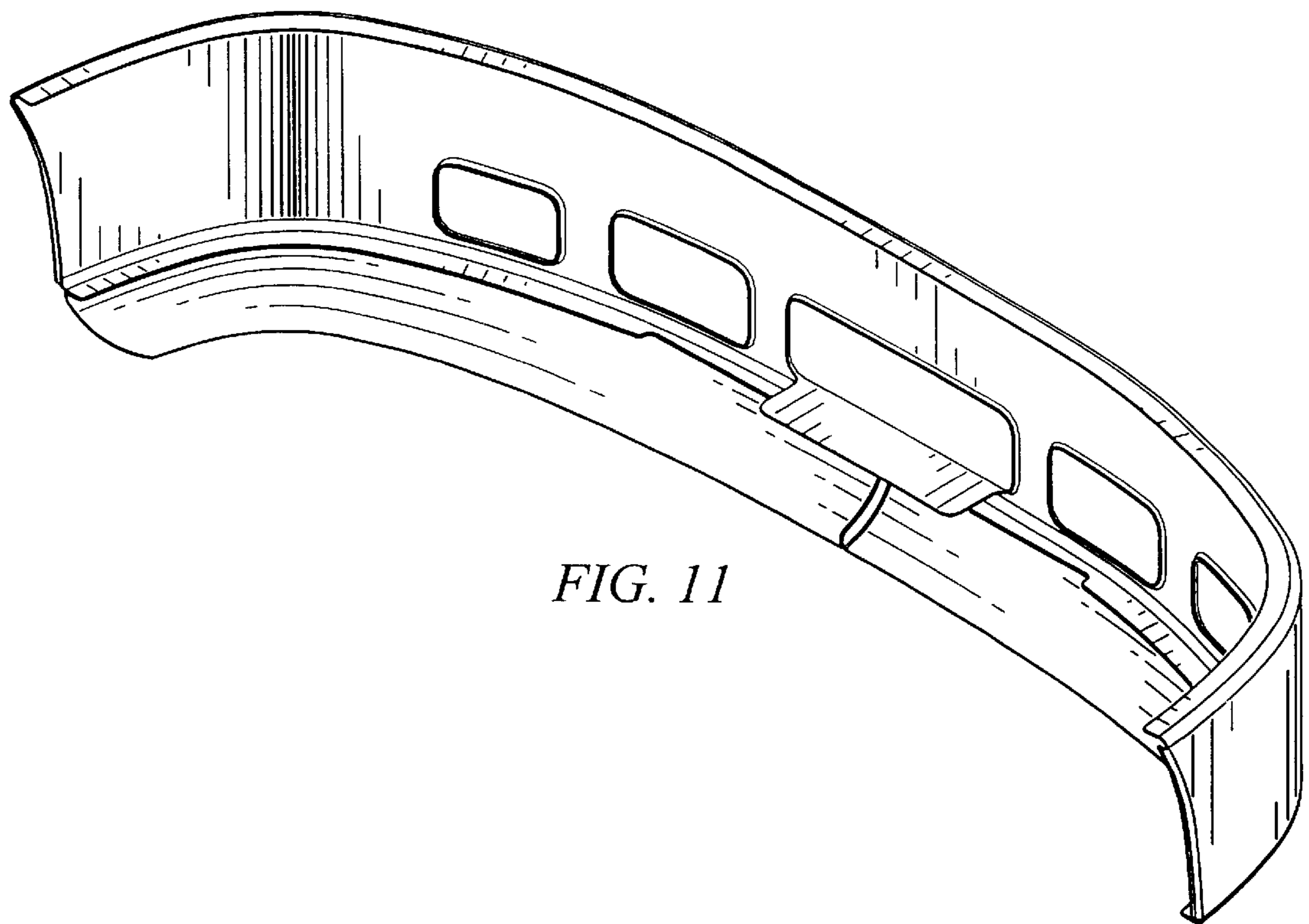

FIG. 11

FIG. 12

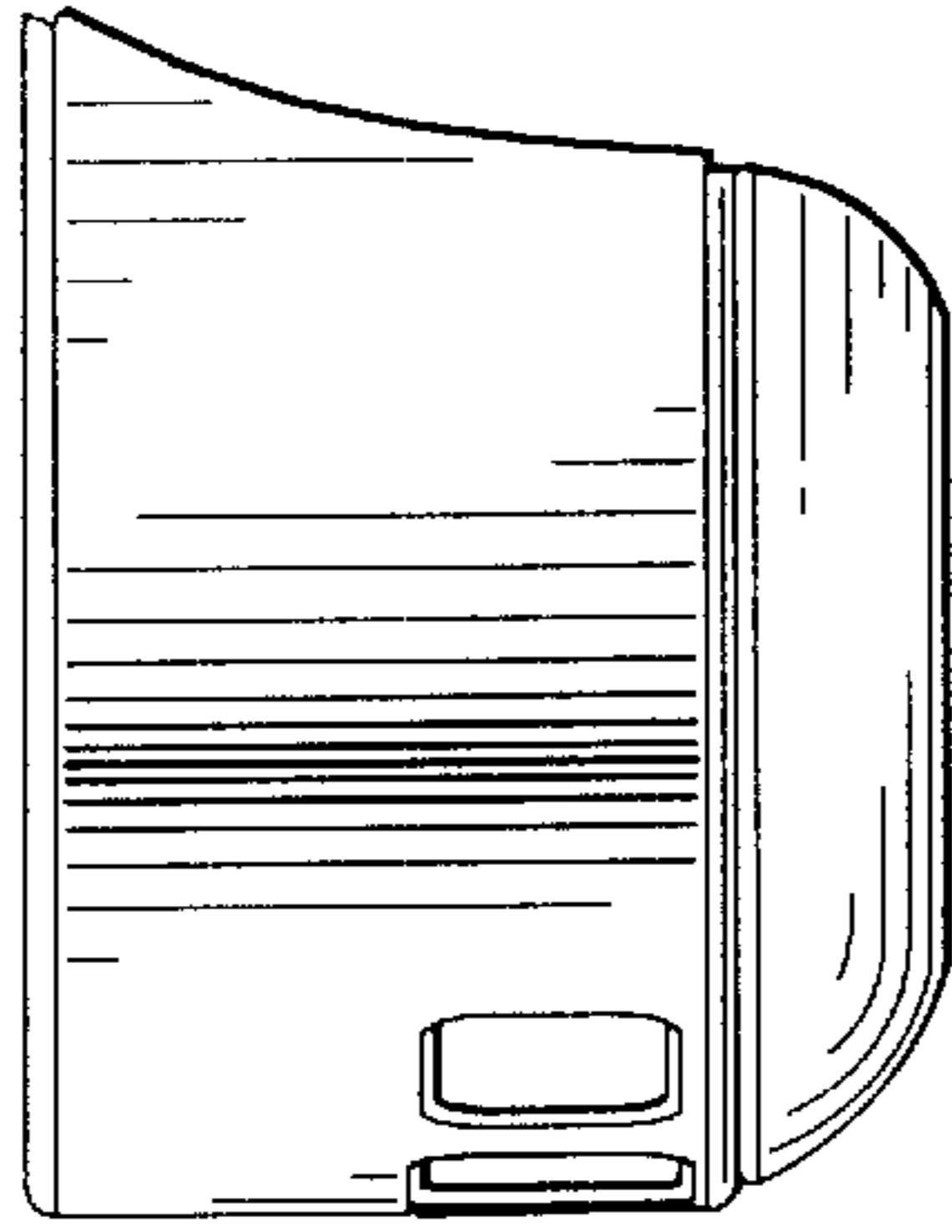
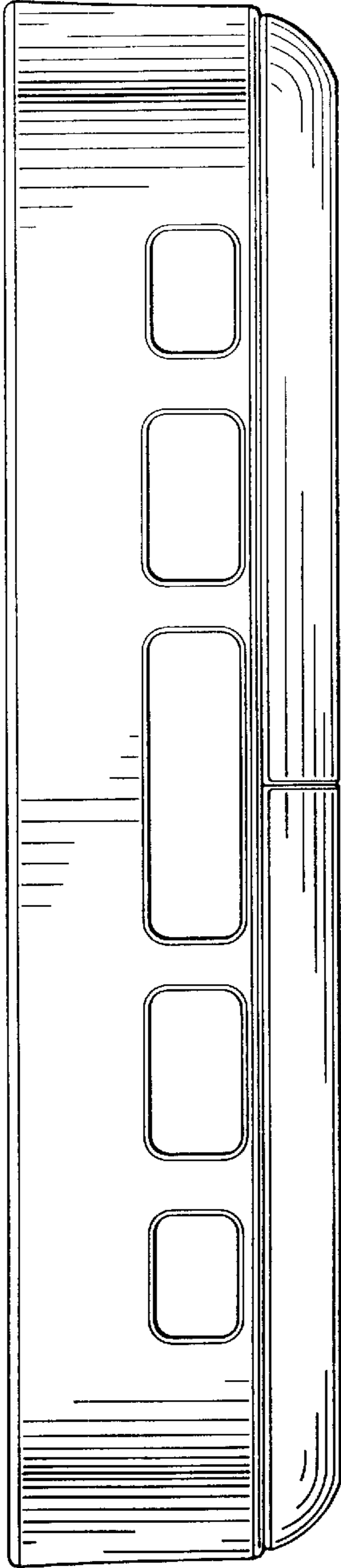

FIG. 14

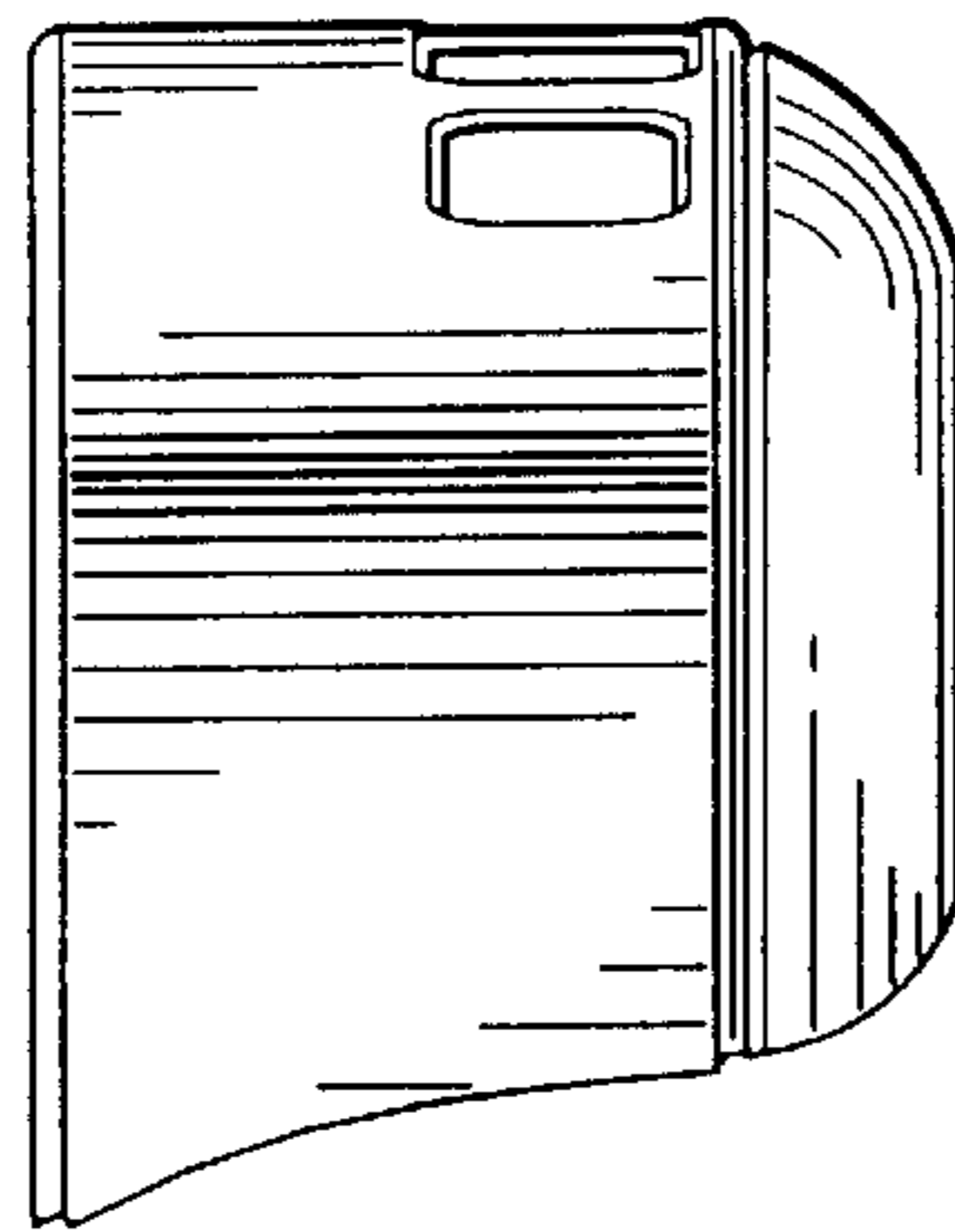

FIG. 13

FIG. 15

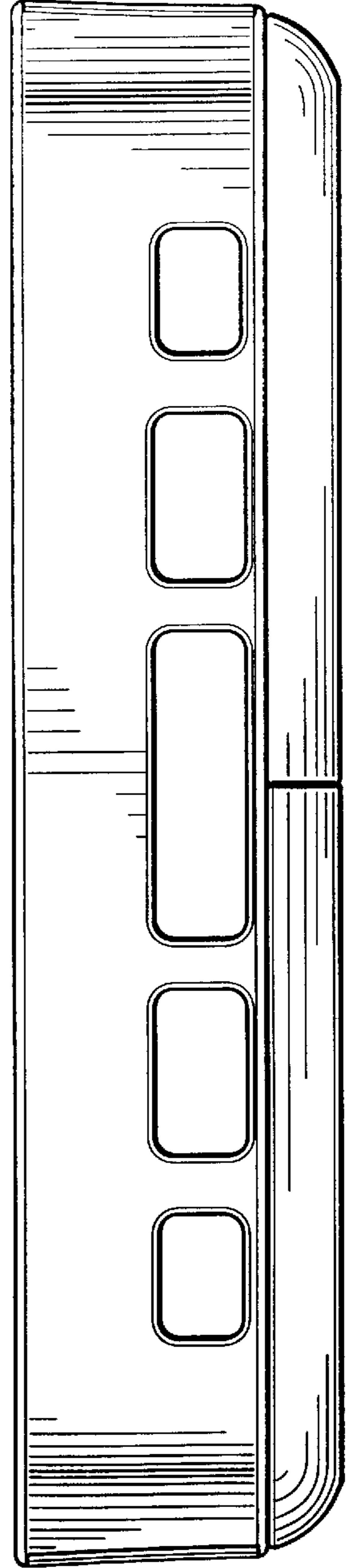

FIG. 16

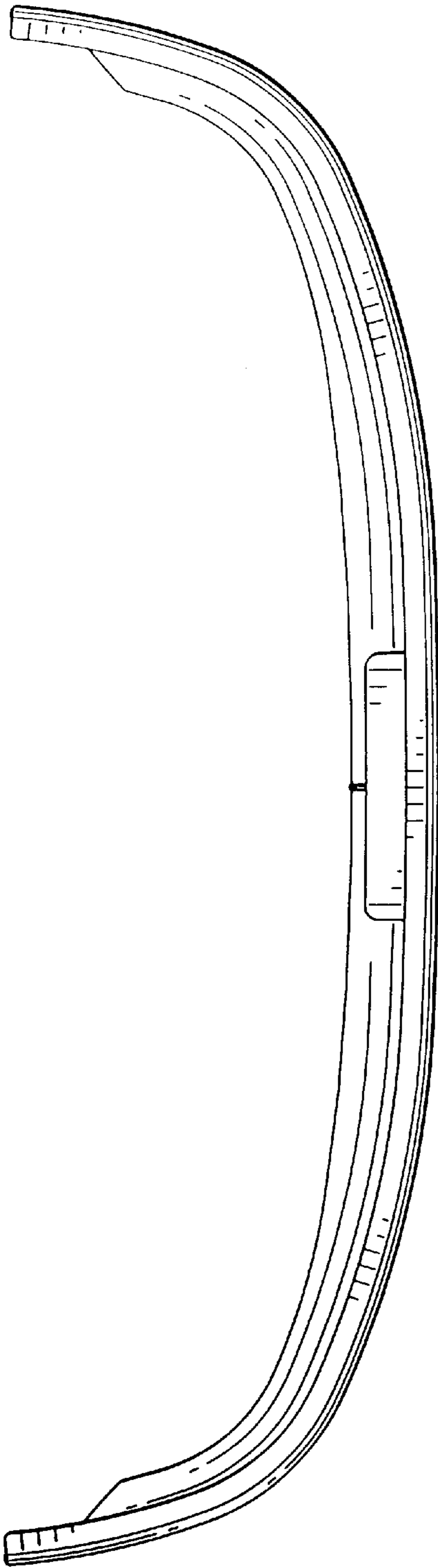
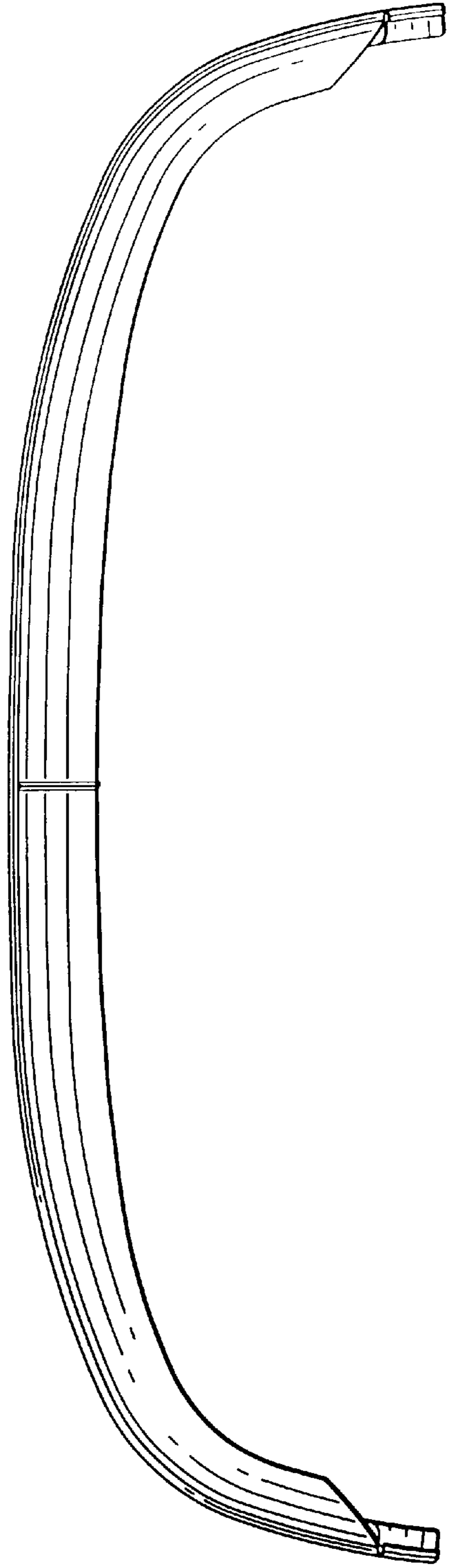

FIG. 17



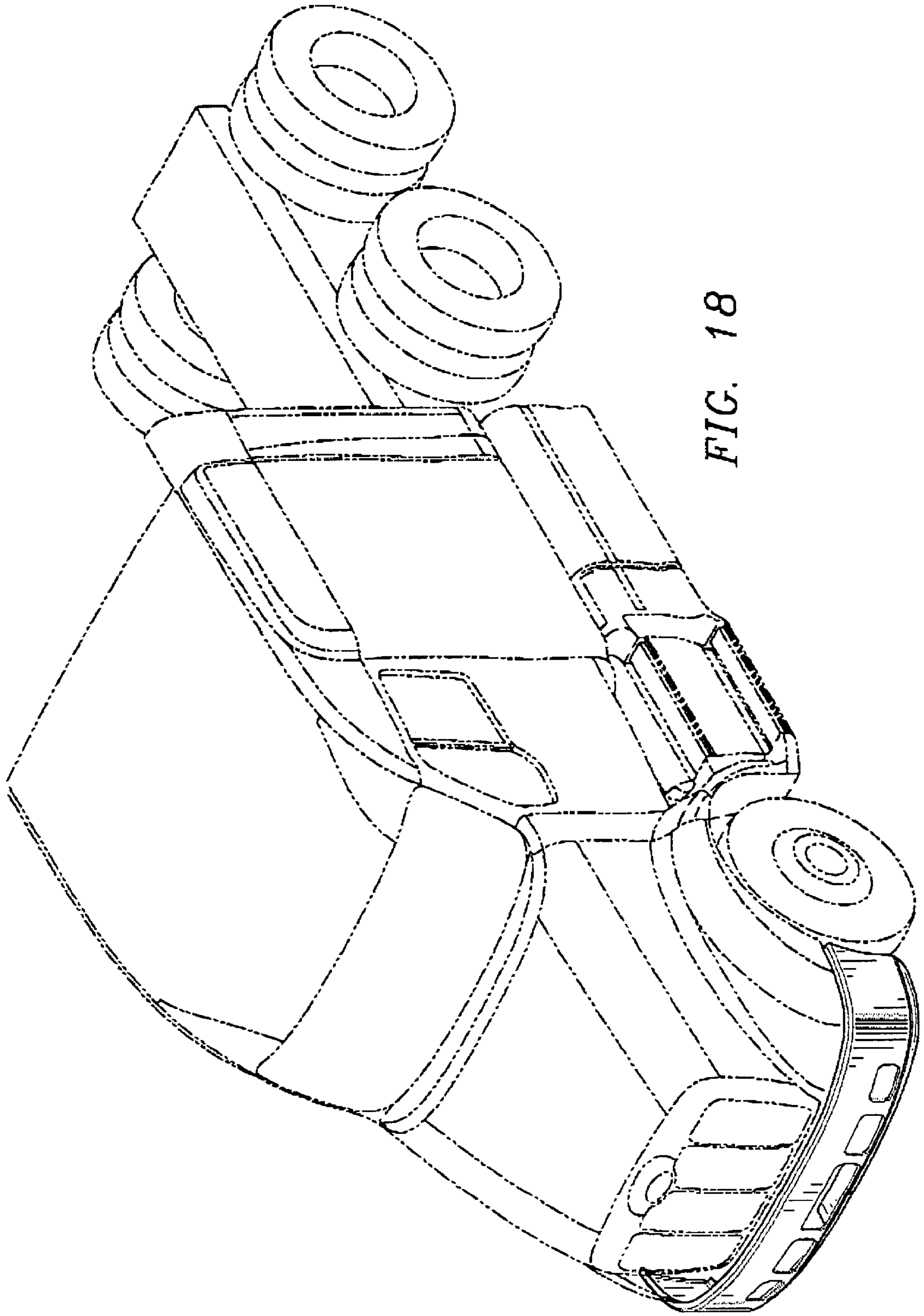

FIG. 18