



US00D482301S

(12) **United States Design Patent**  
**Chosa**

(10) **Patent No.:** **US D482,301 S**

(45) **Date of Patent:** **\*\* Nov. 18, 2003**

(54) **MOTORCYCLE**

(75) Inventor: **Hiroaki Chosa**, Hamamatsu (JP)

(73) Assignee: **Suzuki Motor Corporation**,  
Shizuoka-Pref. (JP)

(\*\*) Term: **14 Years**

(21) Appl. No.: **29/167,250**

(22) Filed: **Sep. 11, 2002**

(30) **Foreign Application Priority Data**

Mar. 12, 2002 (JP) ..... 2002-006474

(51) **LOC (7) Cl.** ..... **12-11**

(52) **U.S. Cl.** ..... **D12/110**

(58) **Field of Search** ..... D12/110; 180/219

(56) **References Cited**

**U.S. PATENT DOCUMENTS**

D389,096 S \* 1/1998 Tako et al. .... D12/110

D403,277 S \* 12/1998 Kokubu et al. .... D12/110

\* cited by examiner

*Primary Examiner*—Alan P. Douglas

*Assistant Examiner*—Linda Brooks

(74) *Attorney, Agent, or Firm*—Foley Hoag LLP

(57) **CLAIM**

The ornamental design for a motorcycle, as shown and described.

**DESCRIPTION**

FIG. 1 is a front perspective view of a motorcycle showing my new design;

FIG. 2 is a rear perspective view thereof;

FIG. 3 is a right side elevational view thereof;

FIG. 4 is a left side elevational view thereof;

FIG. 5 is a top view thereof;

FIG. 6 is a bottom view thereof;

FIG. 7 is a front view thereof; and,

FIG. 8 is a rear view thereof.

The portions of the motorcycle shown in broken lines form no part of the claimed design.

**1 Claim, 8 Drawing Sheets**

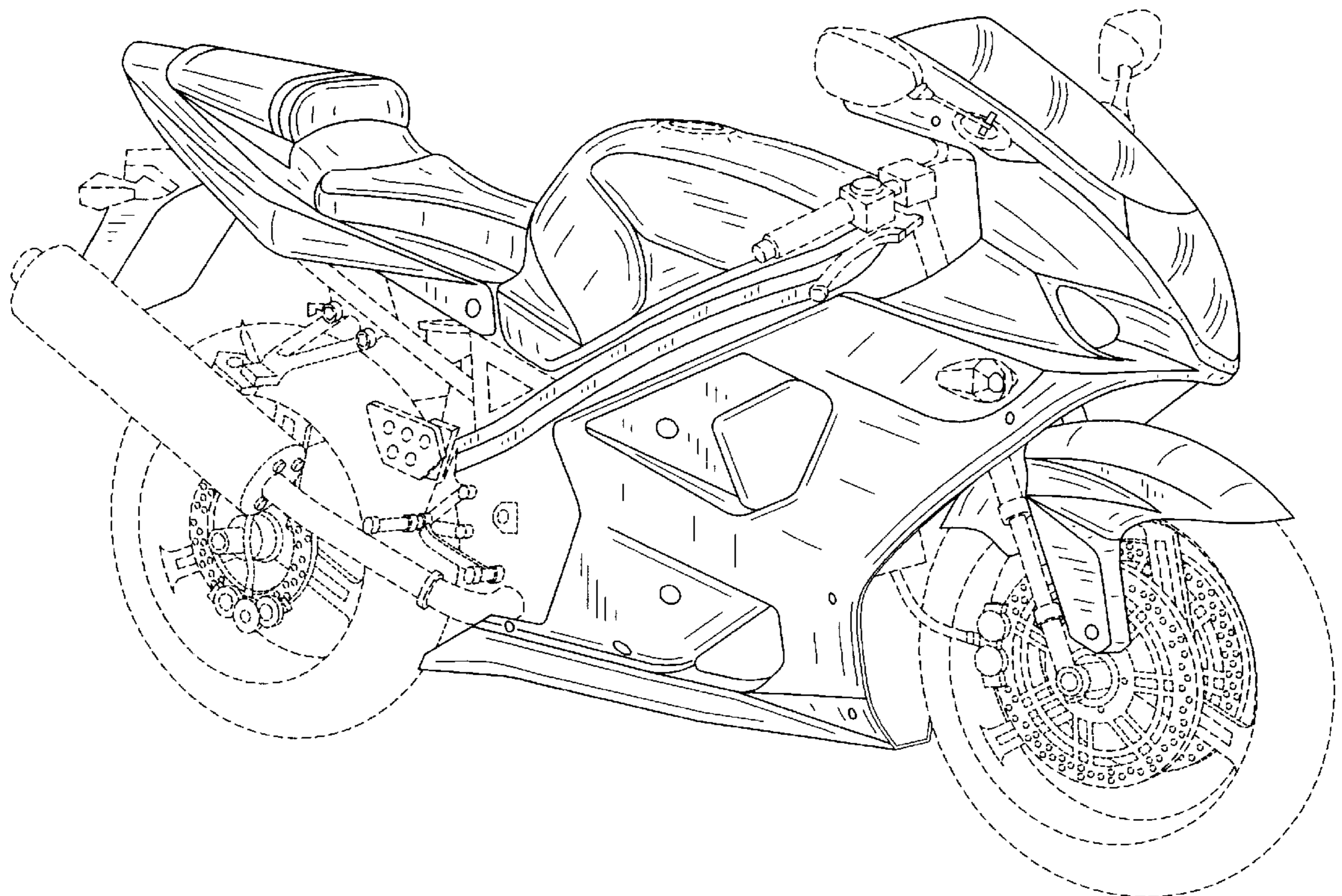

FIG. 1

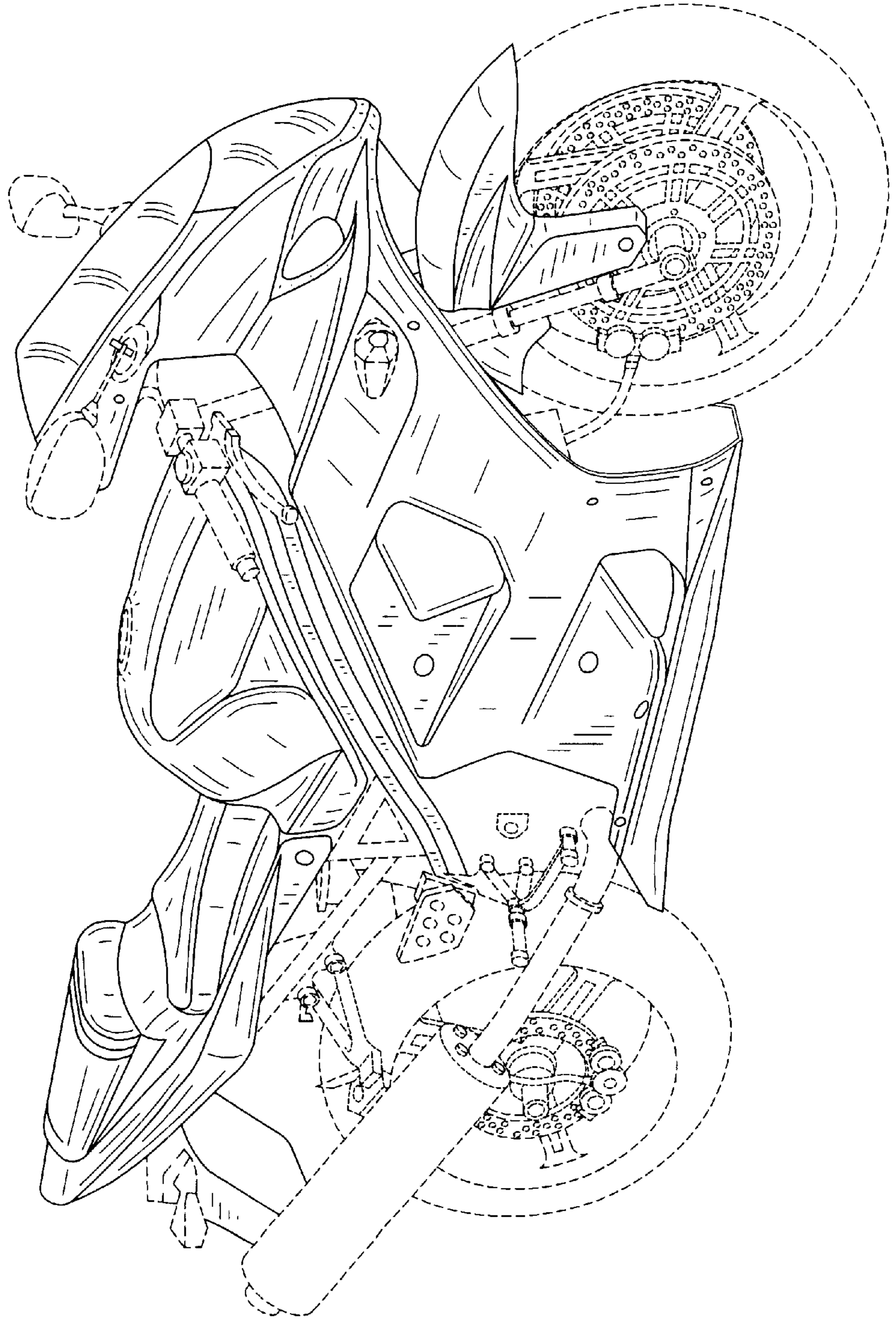

FIG. 2

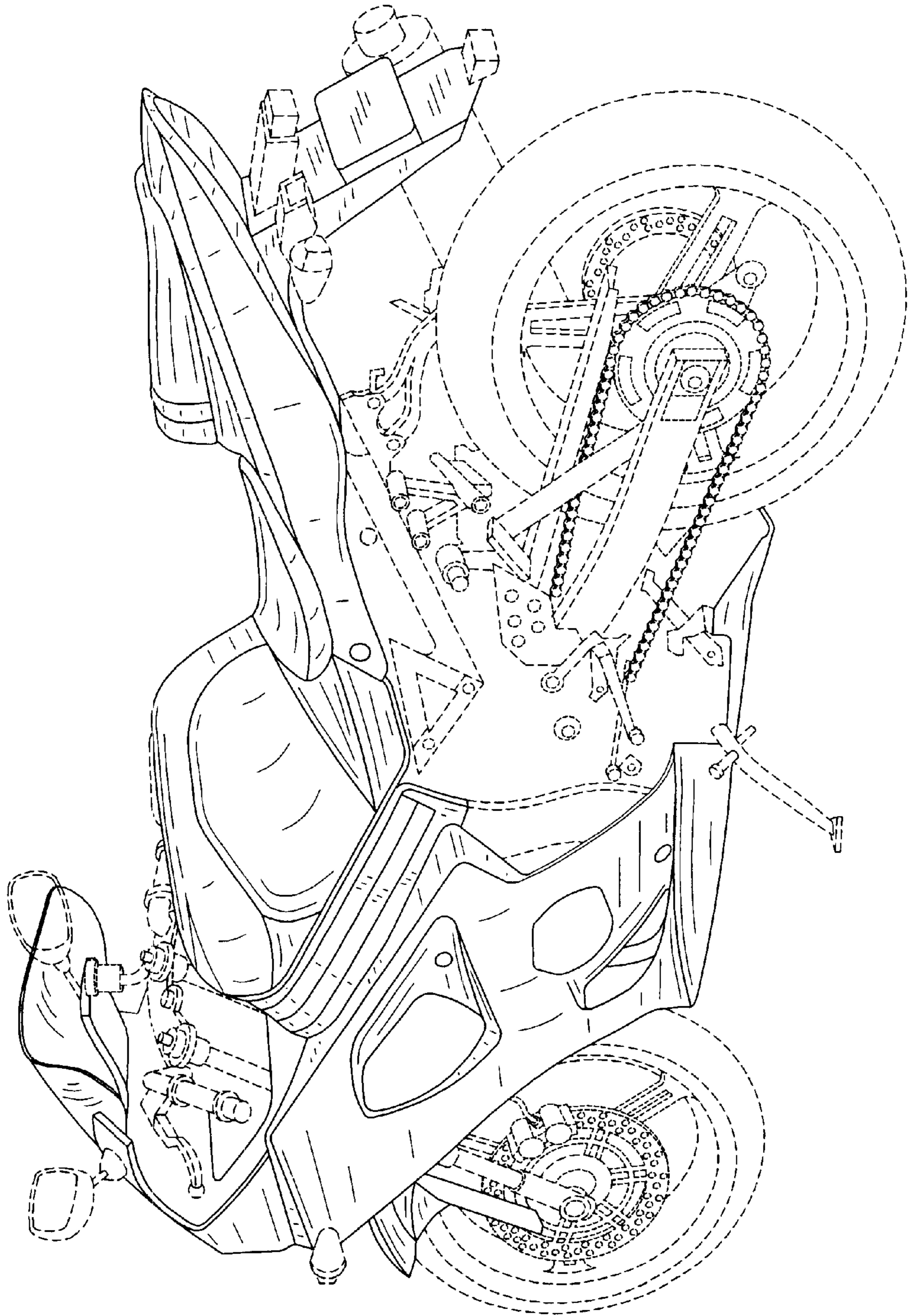

FIG. 3

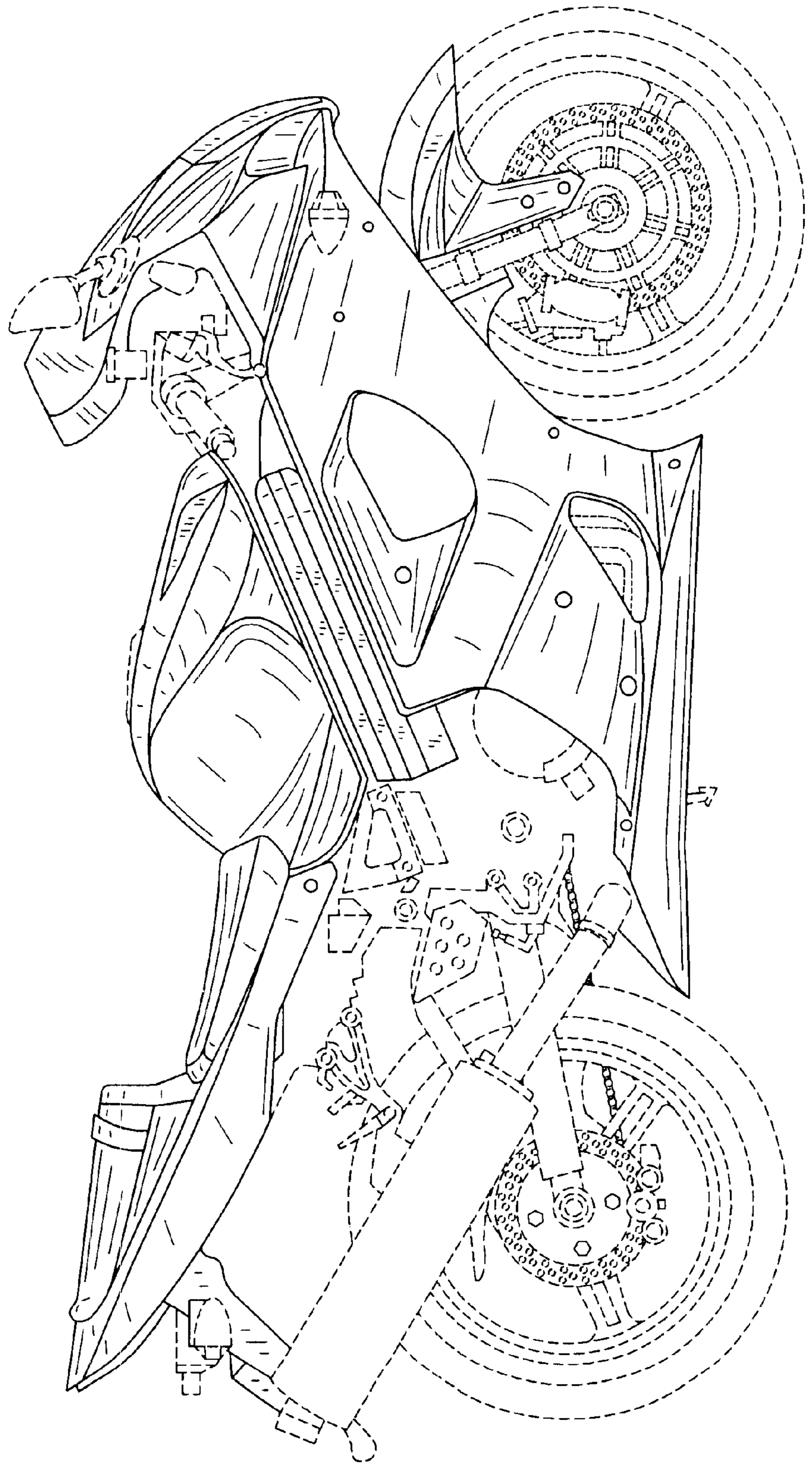

FIG. 4

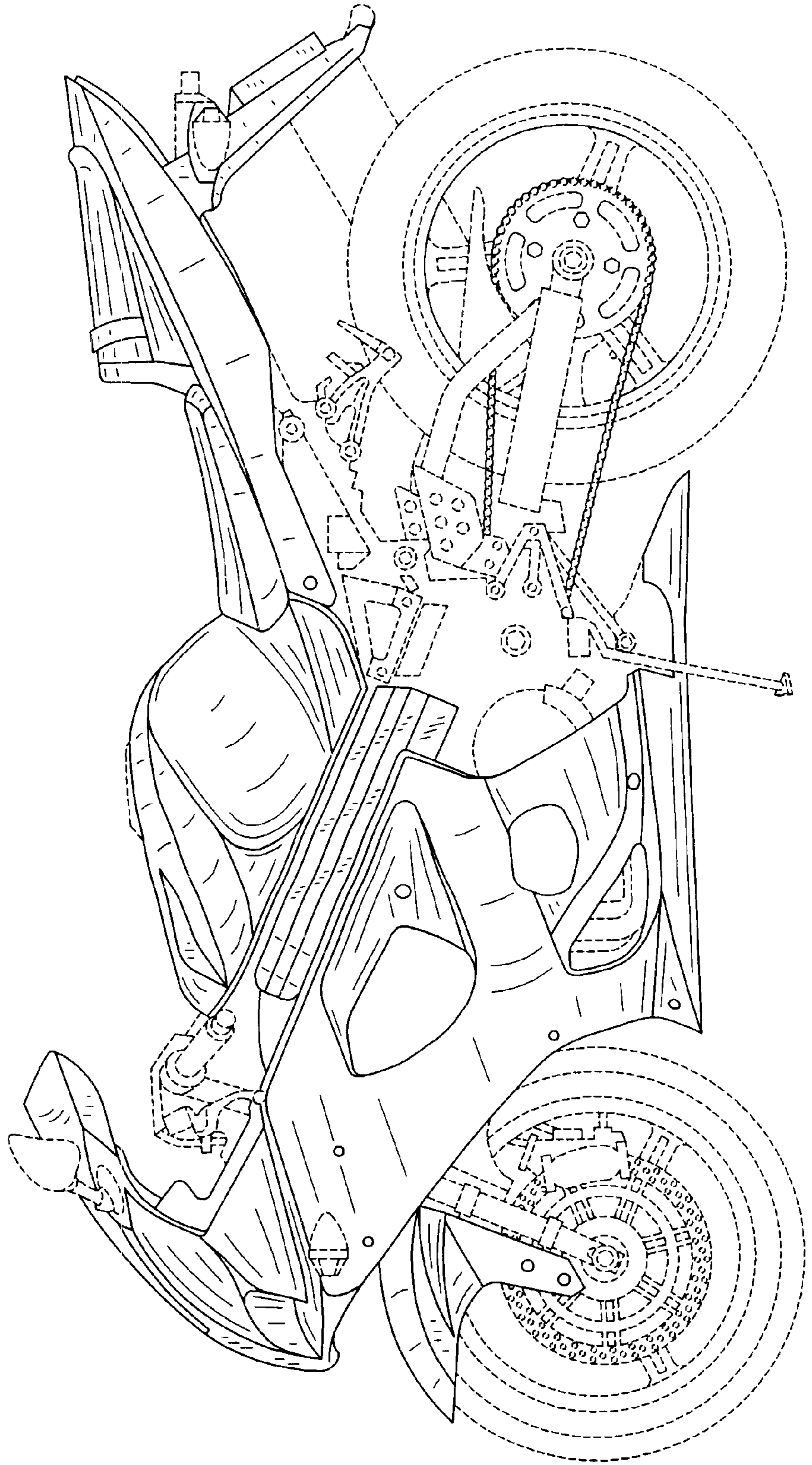

FIG. 5

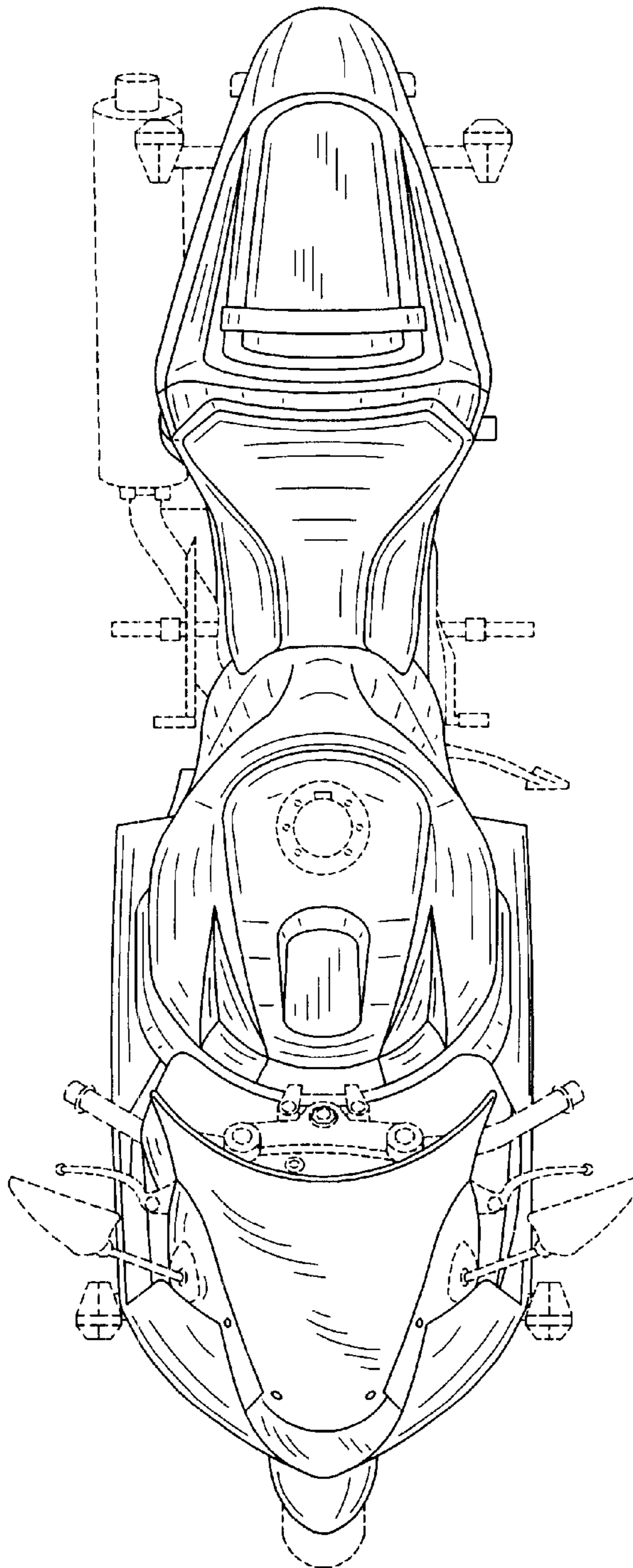
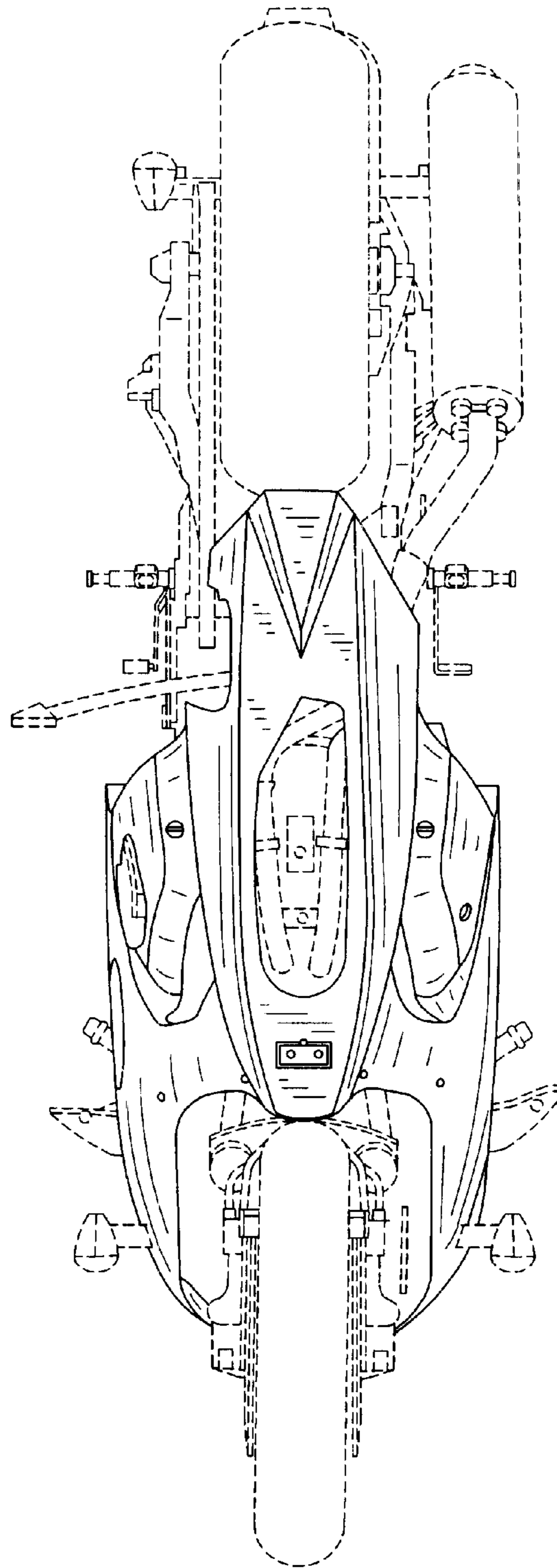
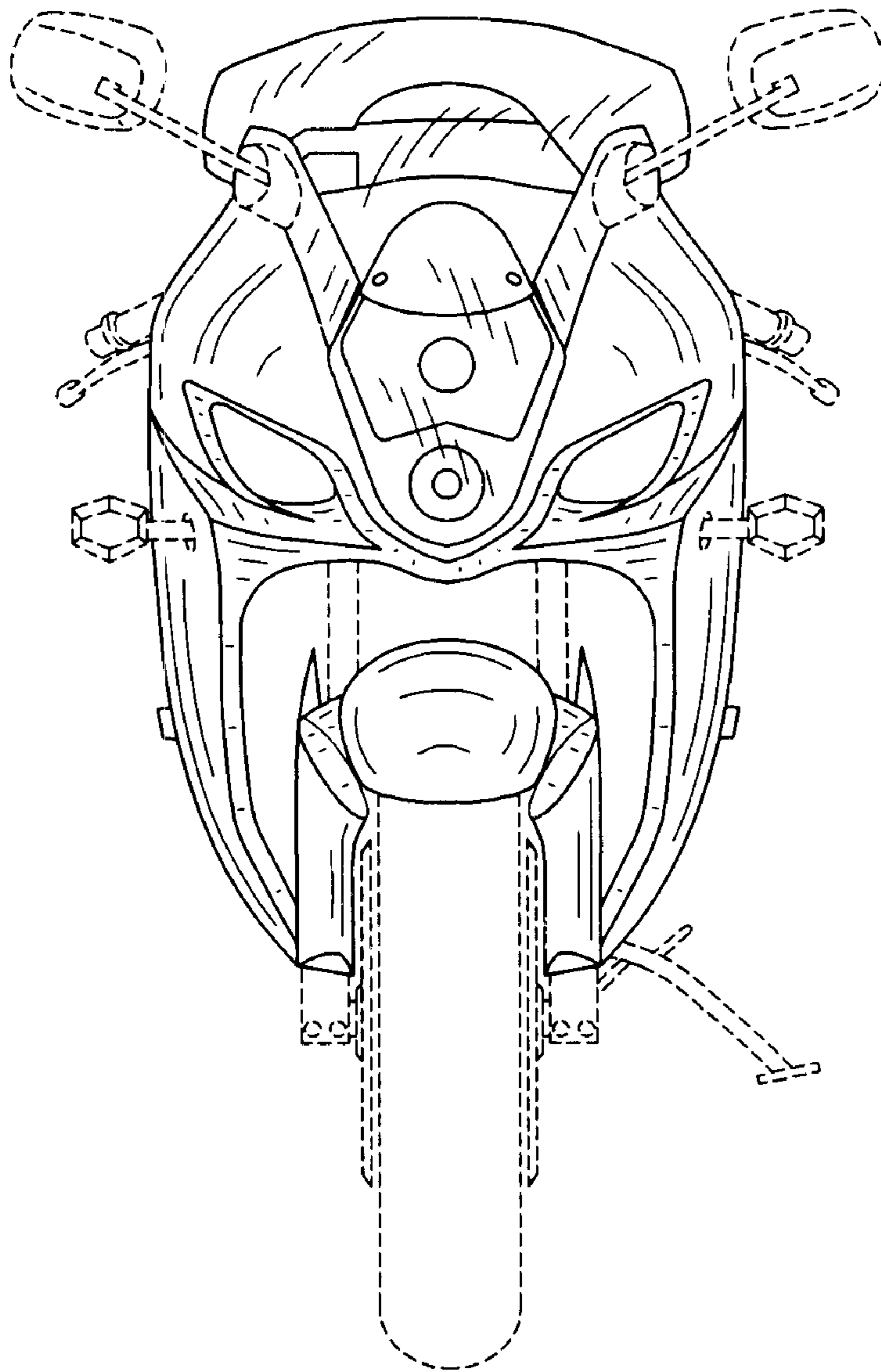

FIG. 6



# FIG. 7





# FIG. 8

