



US00D482300S

(12) **United States Design Patent**
Davidson et al.

(10) **Patent No.: US D482,300 S**

(45) **Date of Patent: ** *Nov. 18, 2003**

(54) **MOTORCYCLE**

Related U.S. Application Data

(75) Inventors: **Willie G. Davidson**, Delafield, WI (US); **Louis Netz**, Grafton, WI (US); **Kirk Rasmussen**, Wales, WI (US); **Jeff Coughlin**, Hartland, WI (US); **Rick Pierson**, New Berlin, WI (US); **Brian Campbell**, Waukesha, WI (US); **Alexander Bozmoski**, Brookfield, WI (US); **Anthony Senger**, New Berlin, WI (US); **Jeff Romenesko**, Pewaukee, WI (US); **Robb Dennert**, Waukesha, WI (US); **Bob Hofmann**, Wauwatosa, WI (US); **Al Zemlicka**, Elkhart, WI (US); **Mike Hamann**, Pewaukee, WI (US); **John Myers**, Glendale, WI (US); **Mike Nixdorf**, Waukesha, WI (US); **Patrick Keller**, Waukesha, WI (US); **Manfred Schuermann**, Weissach (DE); **Klaus Fuoss**, Balingen (DE); **Andreas Schneider**, Leonberg (DE); **Thomas Geffert**, Boennigheim (DE); **Stefan Fegg**, Muenschingen (DE); **Johannes Weyandt**, Illingen (DE); **Wolfgang Schnepf**, Serres (DE); **Alfons Linder**, Pforzheim (DE); **James McNaughton**, Milwaukee, WI (US); **Frank Savage**, Germantown, WI (US); **Paul Lohr**, Waukesha, WI (US); **Friedrich Seiler**, Pforzheim (DE); **Chris Ojstrsek**, Slinger, WI (US)

(63) Continuation of application No. 29/144,703, filed on Jul. 9, 2001, now Pat. No. Des. 462,638.

(51) **LOC (7) Cl.** 12-11

(52) **U.S. Cl.** D12/110

(58) **Field of Search** D12/110; 180/219

(56) **References Cited**

U.S. PATENT DOCUMENTS

D344,046 S 2/1994 Kitagawa et al.
D442,521 S 5/2001 Pan

OTHER PUBLICATIONS

A photograph of a FLSTF Fat Boy, published in "Harley-Davidson Model Year 2001 Motorcycles," the publication has a copyright date of 2000, published prior to Jul. 9, 2001.

(List continued on next page.)

Primary Examiner—Alan P. Douglas

Assistant Examiner—Linda Brooks

(74) *Attorney, Agent, or Firm*—Michael Best & Friedrich, LLP

(57) **CLAIM**

We claim the ornamental design for a motorcycle, as shown and described.

DESCRIPTION

FIG. 1 is a front perspective view of the left side of a motorcycle embodying the present invention.

FIG. 2 is a left side view of the motorcycle shown in FIG. 1.

FIG. 3 is a right side view of the motorcycle shown in FIG. 1.

FIG. 4 is a top view of the motorcycle shown in FIG. 1.

FIG. 5 is a front view of the motorcycle shown in FIG. 1; and,

FIG. 6 is a rear view of the motorcycle shown in FIG. 1.

(73) Assignee: **Harley-Davidson Motor Company Group, Inc.**, Milwaukee, WI (US)

(*) Notice: This patent is subject to a terminal disclaimer.

(**) Term: **14 Years**

(21) Appl. No.: **29/160,649**

(22) Filed: **May 13, 2002**

1 Claim, 5 Drawing Sheets

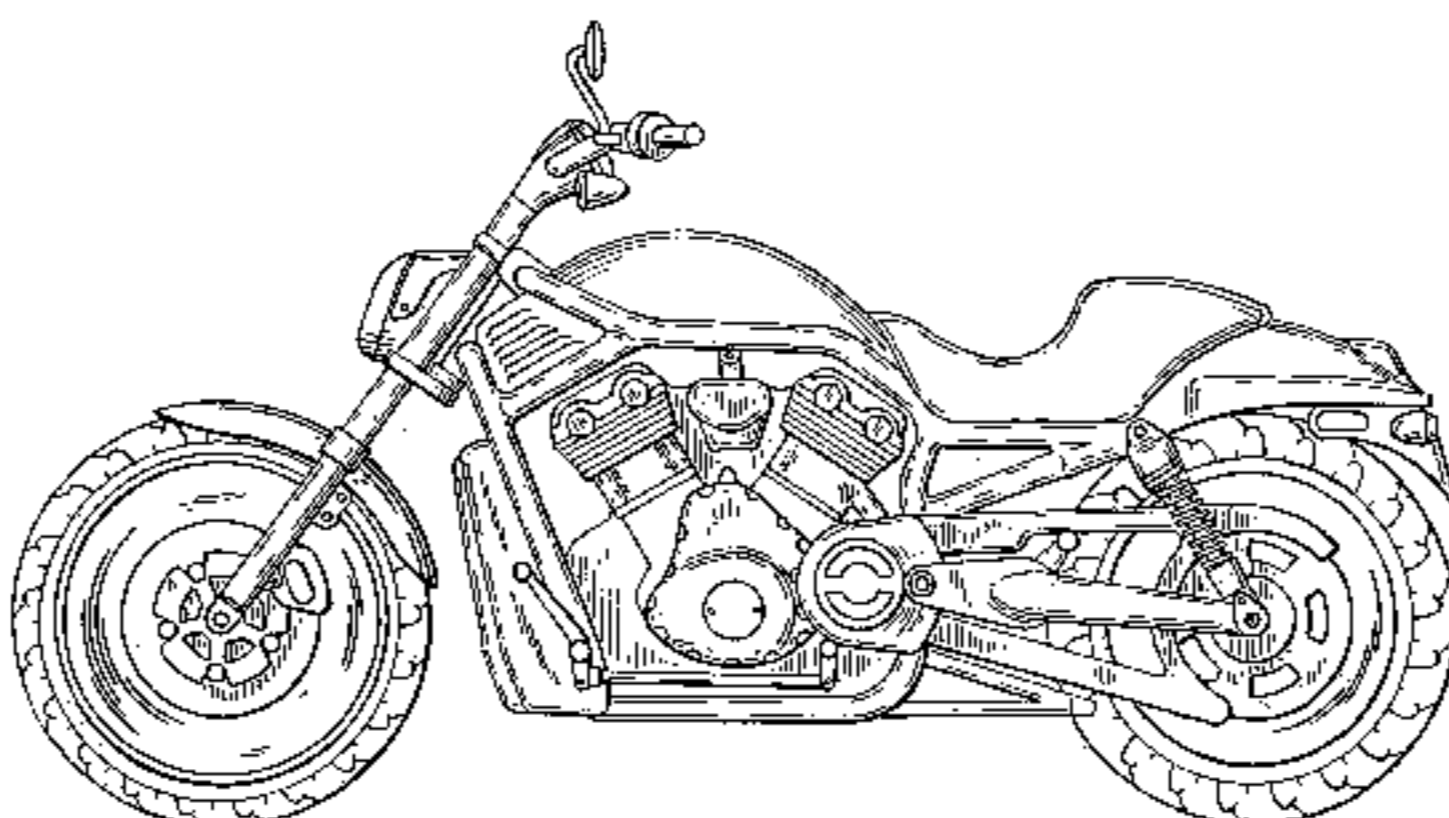
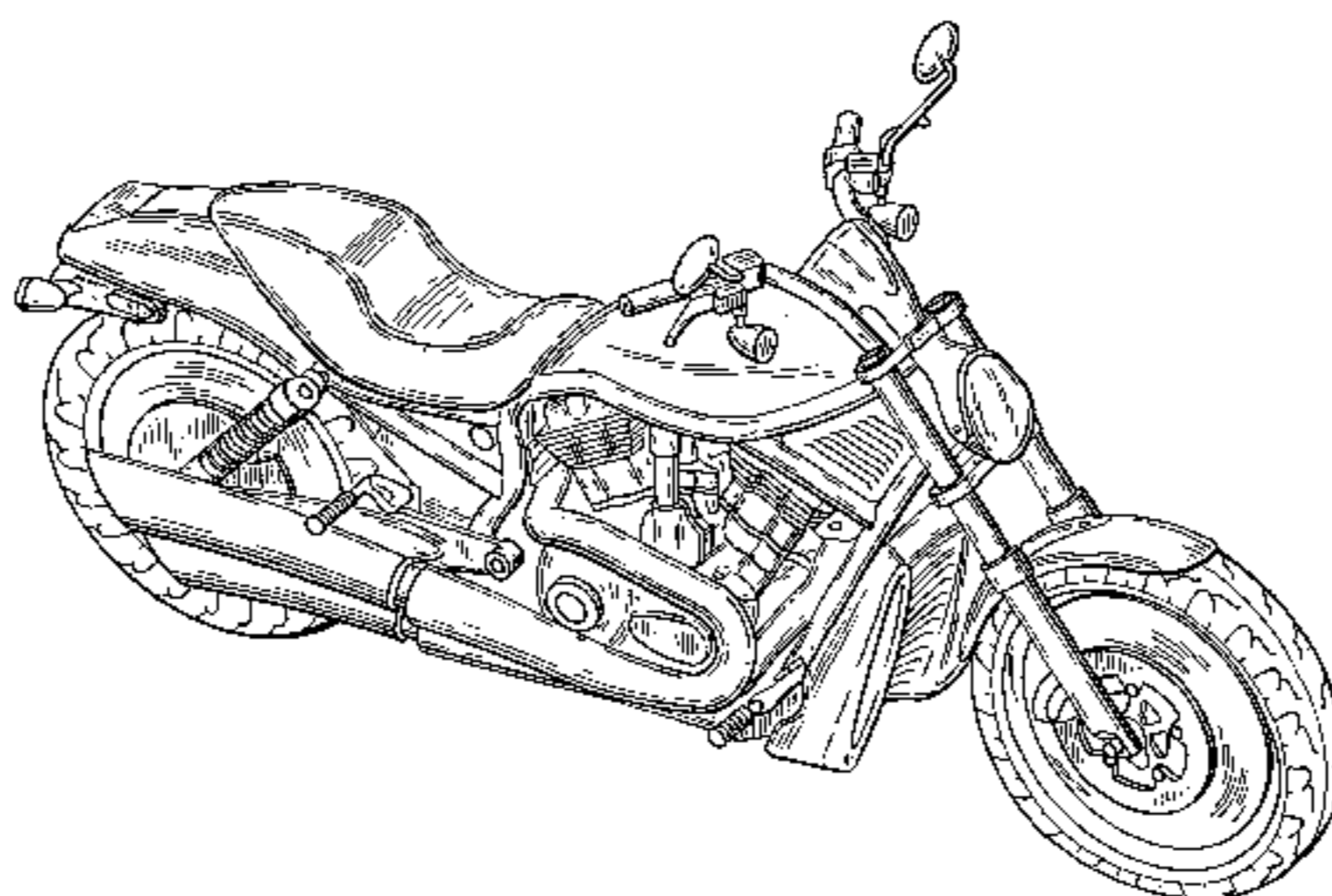

OTHER PUBLICATIONS

A photograph of a 2001 FXDL Dyna Low Rider, published in "Harley-Davidson: 2001 Genuine Motor Accessories and Genuine Motor Parts," pp. 2 and 3, published prior to Jul. 9, 2001.

A photograph of a 2001 Sportster 1200 Sport XL 1200S, published in "Harley-Davidson: 2001 Genuine Motor Accessories and Genuine Motor Parts," pp. 18 and 19, published prior to Jul. 9, 2001.

A photograph of a 2001 Sportster 883 Huffer XLH, published in "Harley-Davidson: 2001 Genuine Motor Accessories and Genuine Motor Parts," pp. 96 and 97, published prior to Jul. 9, 2001.

A photograph of a 2001 DYNA Super Glide FXD, published in "Harley-Davidson: 2001 Genuine Motor Accessories and Genuine Motor Parts," pp. 166 and 167, published prior to Jul. 9, 2001.

A photograph of a 2001 DYNA Super Glide T-Sport FXDXT, published in "Harley-Davidson: 2001 Genuine Motor Accessories and Genuine Motor Parts," pp. 168 and 169, published prior to Jul. 9, 2001.

A photograph of 2001 DYNA Wide Glide FXDWG, published in "Harley-Davidson: 2001 Genuine Motor Accessories and Genuine Motor Parts," p. 171, published prior to Jul. 9, 2001.

A photograph of a 1998 DYNA Super Glide FXD, published in "Harley-Davidson: 2001 Genuine Motor Accessories and Genuine Motor Parts," pp. 172 and 173, published prior to Jul. 9, 2001.

A photograph of a 2001 Fat Boy FLSTFL, published in "Harley-Davidson: 2001 Genuine Motor Accessories and Genuine Motor Parts," pp. 240 and 241, published prior to Jul. 9, 2001.

A photograph of a 2001 Heritage Softail Classic FLSTCI, published in "Harley-Davidson: 2001 Genuine Motor Accessories and Genuine Motor Parts," p. 241, published prior to Jul. 9, 2001.

A photograph of a 2001 Heritage Softail Classic, published in "Harley-Davidson: 2001 Genuine Motor Accessories and Genuine Motor Parts," p. 244, published prior to Jul. 9, 2001.

A photograph of a 2001 Softail Deuce FXSTD, published in "Harley-Davidson: 2001 Genuine Motor Accessories and Genuine Motor Parts," pp. 245 and 246, published prior to Jul. 9, 2001.

A photograph of a 2001 Softail Deuce FXSTD, published in "Harley-Davidson: 2001 Genuine Motor Accessories and Genuine Motor Parts," pp. 247 and 248, published prior to Jul. 9, 2001.

A photograph of a 2001 Night Train FXSTBI, published in "Harley-Davidson: 2001 Genuine Motor Accessories and Genuine Motor Parts," p. 250, published prior to Jul. 9, 2001.

A photograph of a 1996 Fat Boy Street Stalker Stage III FLSTF, published in "Harley-Davidson: 2001 Genuine Motor Accessories and Genuine Motor Parts," p. 253 and 254, published prior to Jul. 9, 2001.

A photograph of a 2001 Road King FLHRI, published in "Harley-Davidson: 2001 Genuine Motor Accessories and Genuine Motor Parts," pp. 371 and 372, published prior to Jul. 9, 2001.

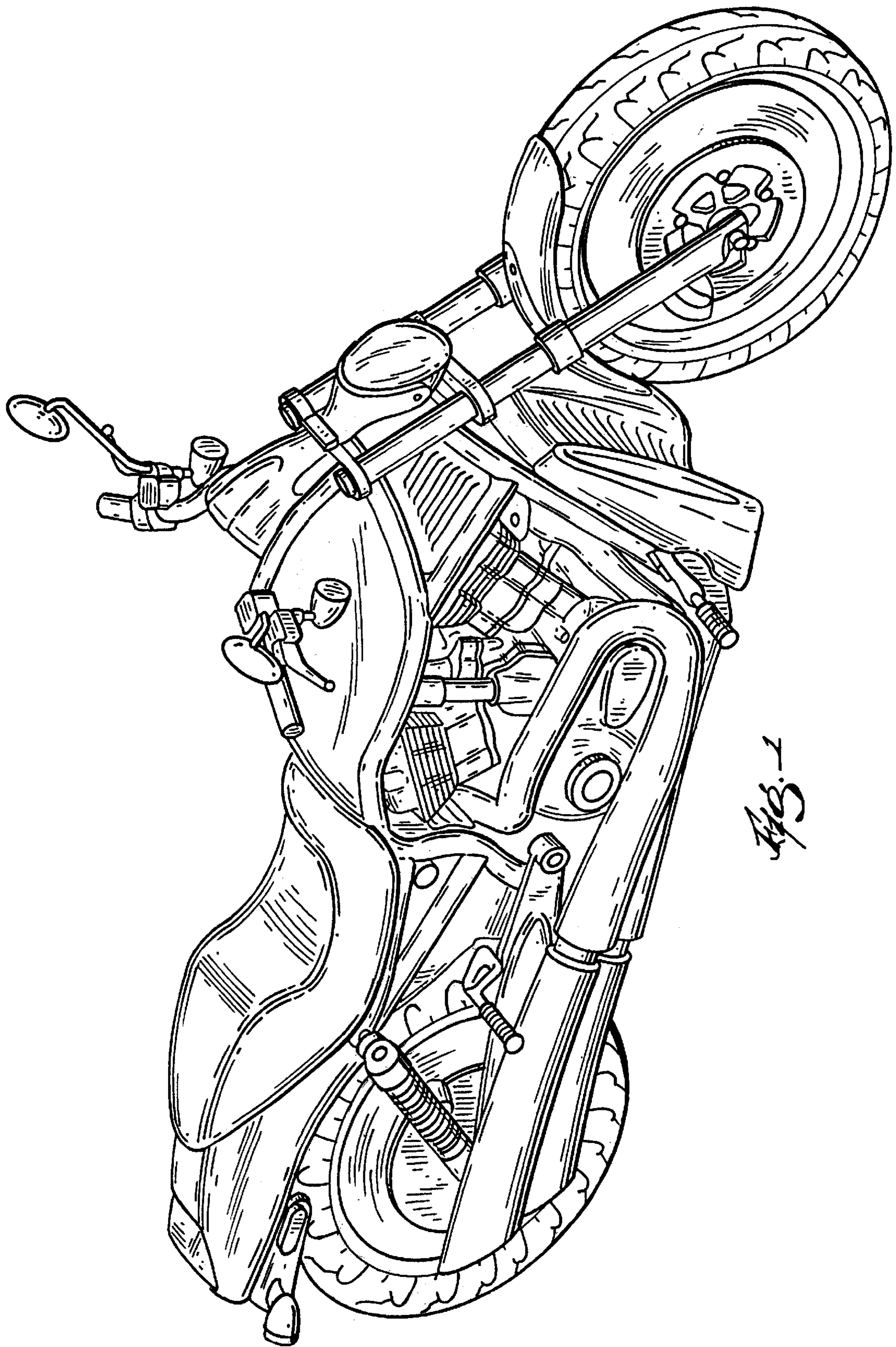

Fig. 1

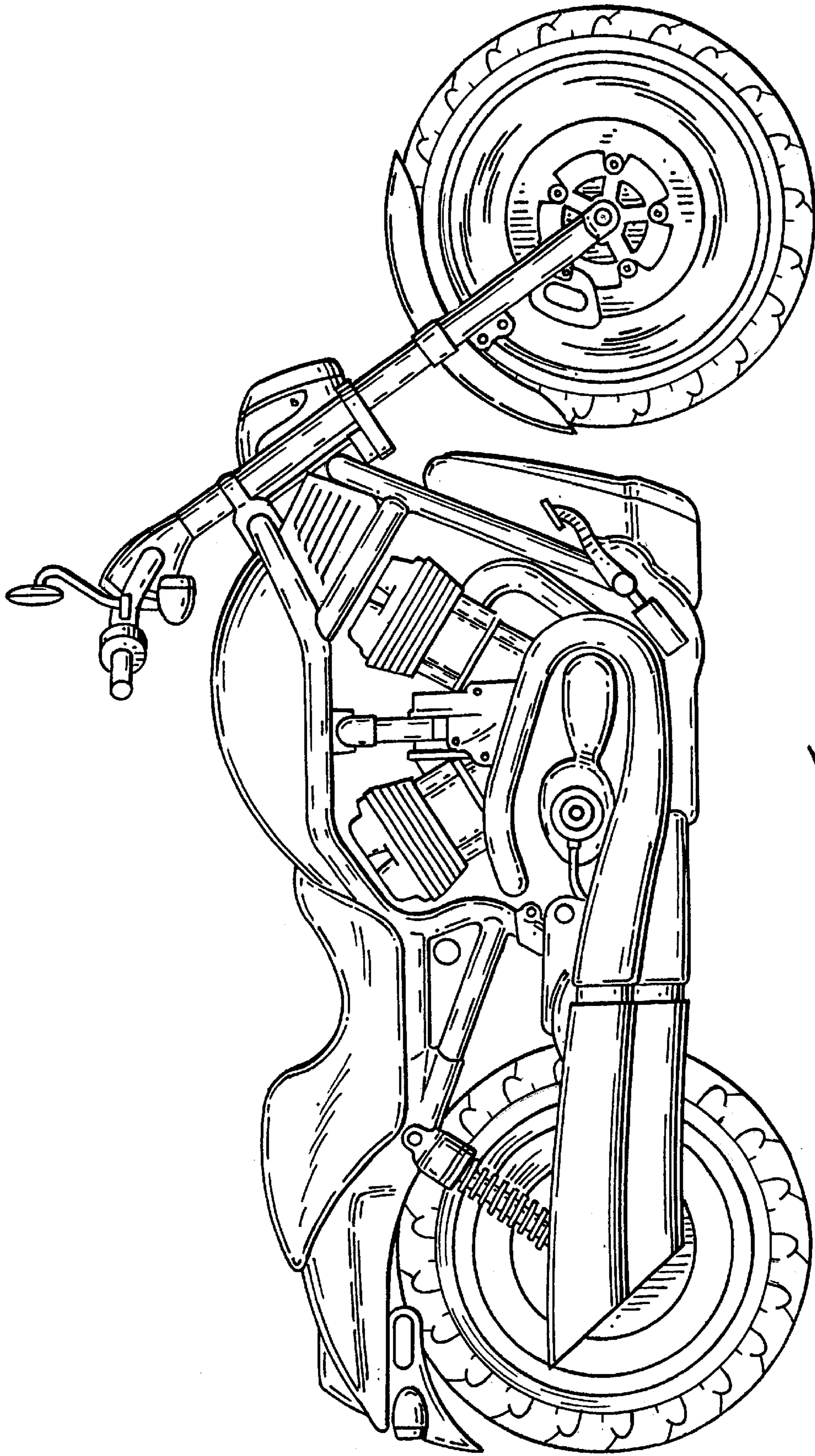

Fig. 2

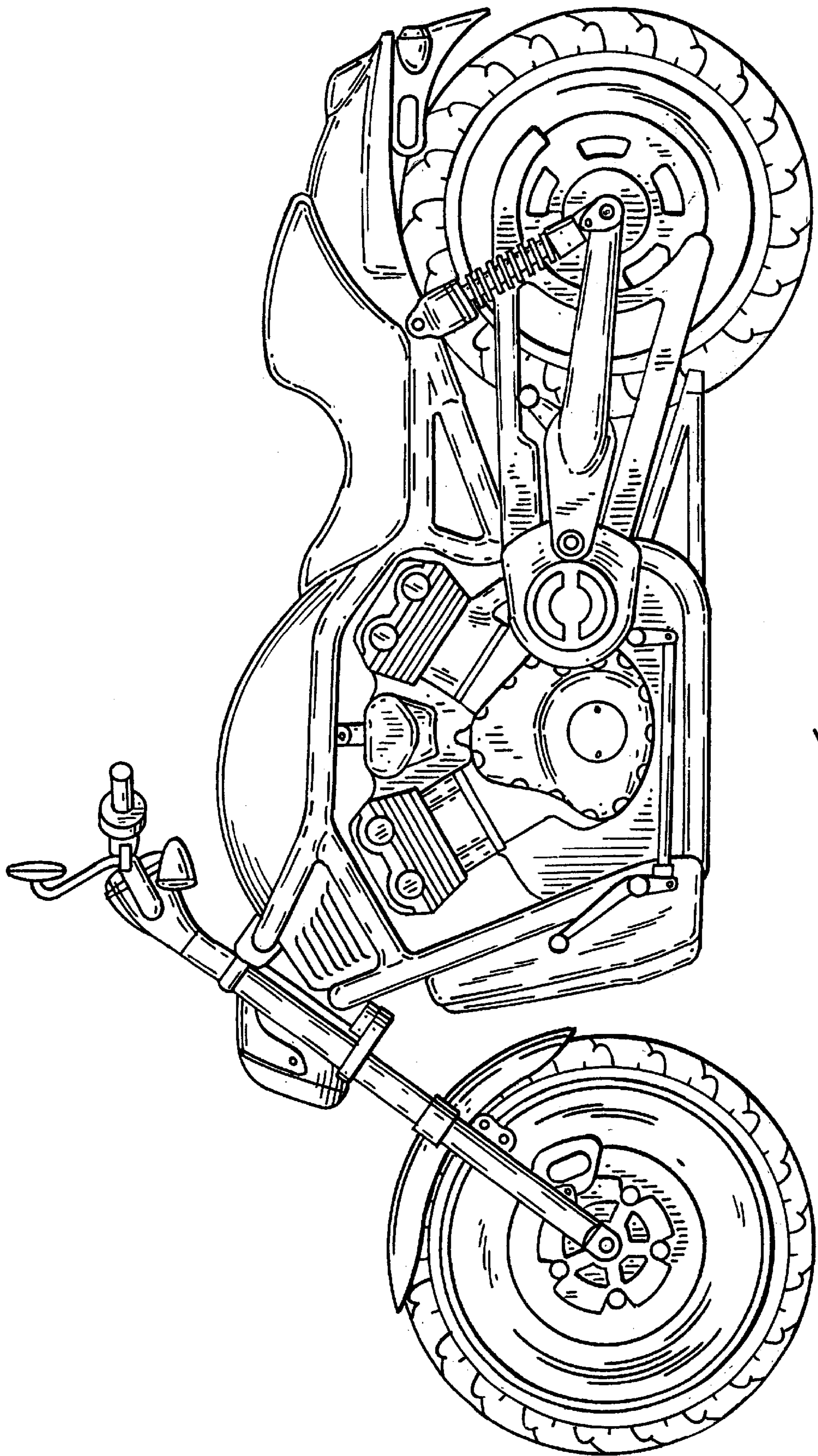

FIG. 3

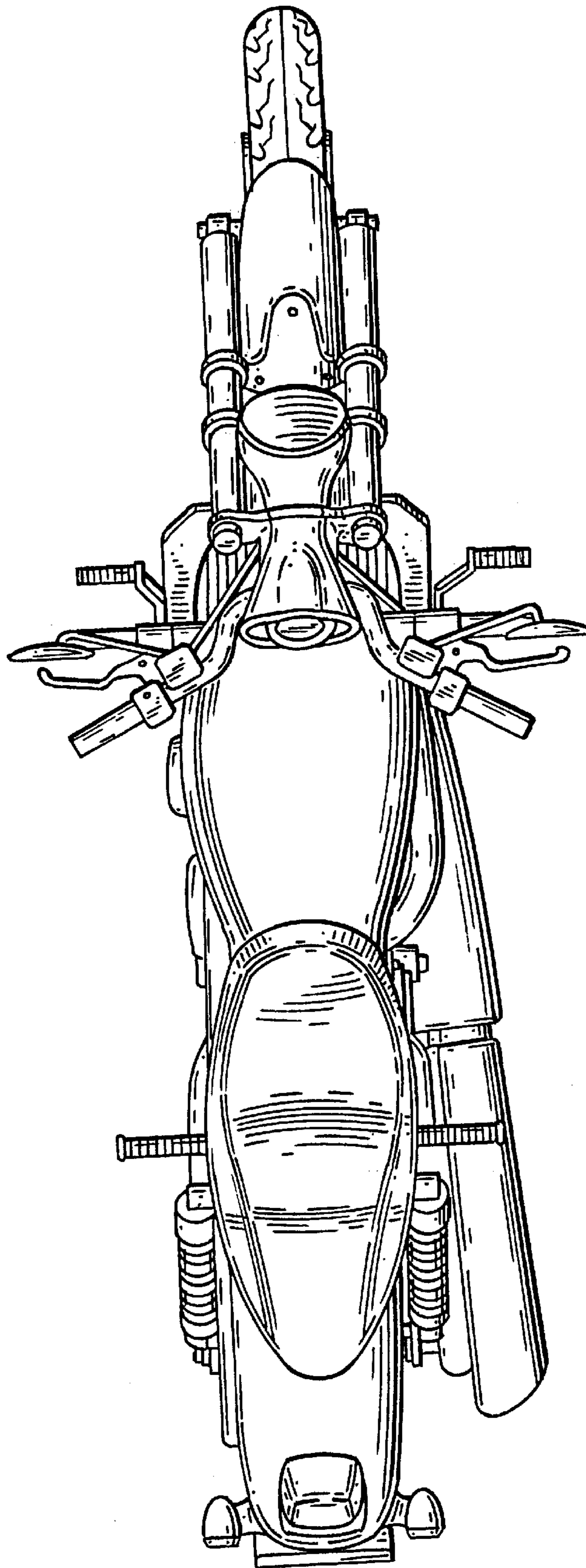

Fig. 4

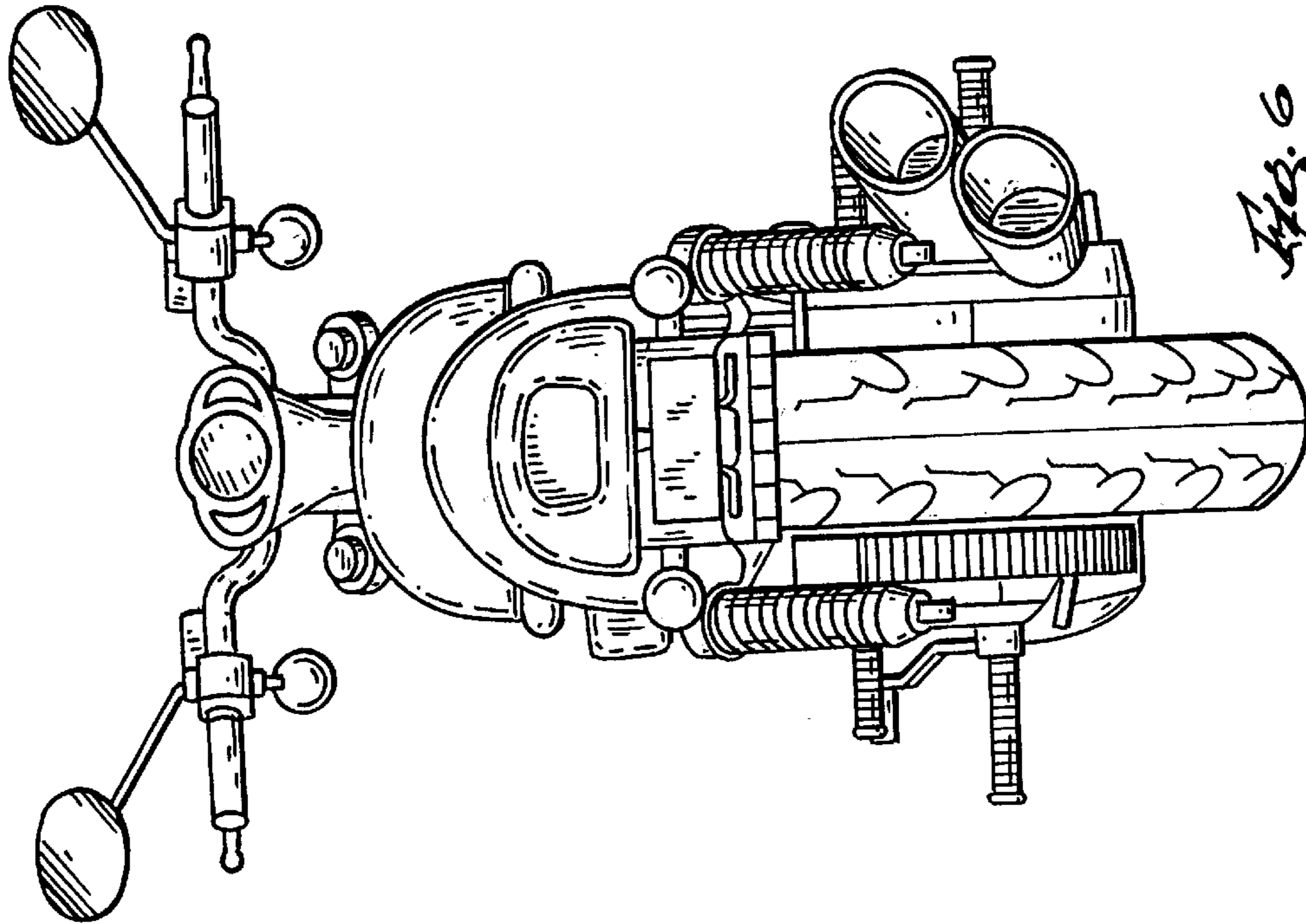

Fig. 6

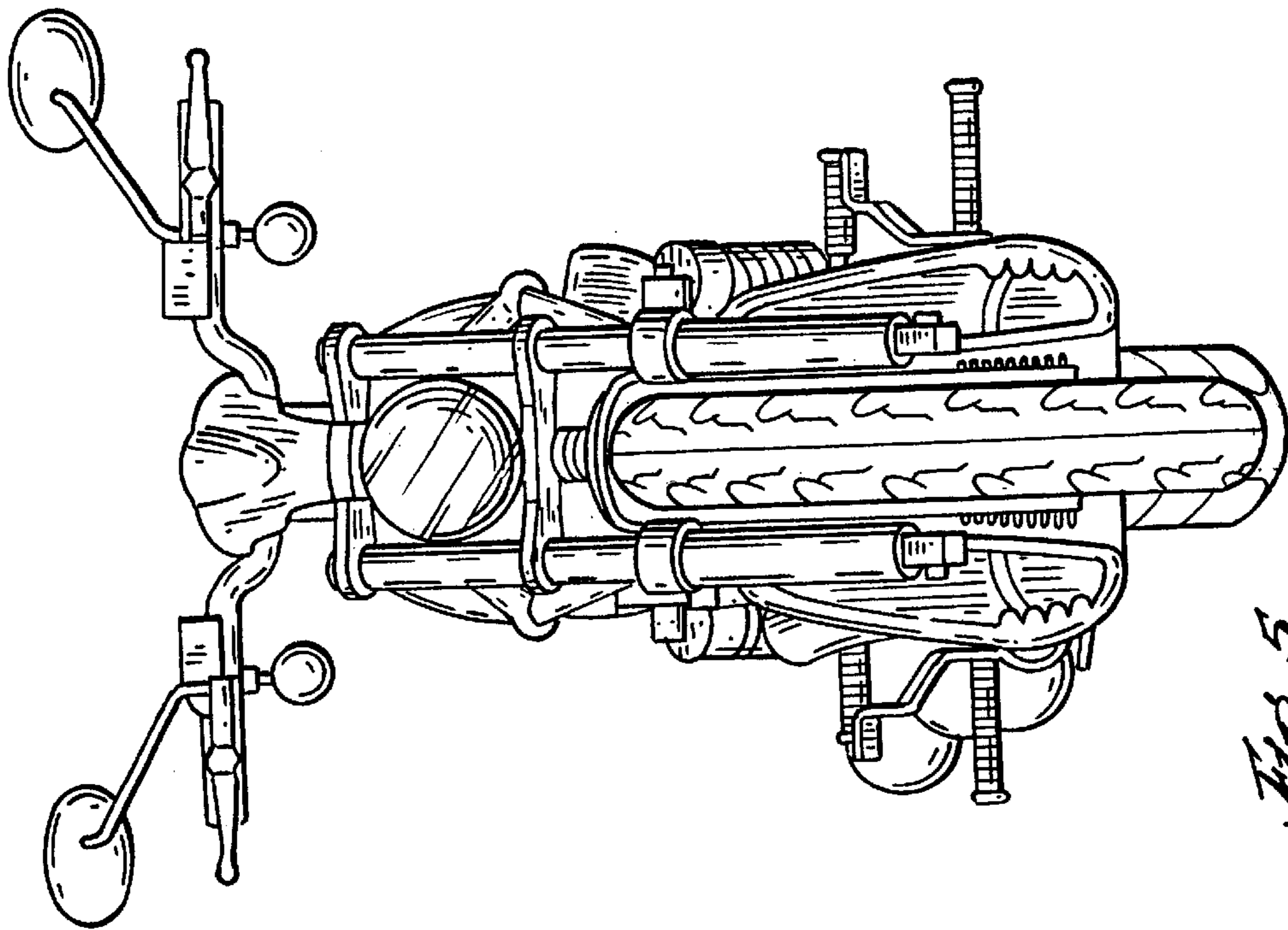

Fig. 5