



US00D482170S

(12) **United States Design Patent**
Yang

(10) **Patent No.:** **US D482,170 S**

(45) **Date of Patent:** **** Nov. 11, 2003**

(54) **DOUBLE RAILS GOLF CART**

(76) Inventor: **Lien-Chuan Yang**, 11F-1, No. 149,
Roosevelt Rd. Sec. 3, Taipei (TW)

(**) Term: **14 Years**

(21) Appl. No.: **29/169,523**

(22) Filed: **Oct. 23, 2002**

(51) **LOC (7) Cl.** **12-02**

(52) **U.S. Cl.** **D34/15**

(58) **Field of Search** D34/12-27; 280/DIG. 5,
280/DIG. 6, 641, 646, 655; 180/19.1, 19.3,
215, 216, 907

(56) **References Cited**

U.S. PATENT DOCUMENTS

D423,746 S	*	4/2000	Liao	D34/15
D436,707 S	*	1/2001	Liao	D34/15
D437,985 S	*	2/2001	Wu	D34/15
D438,357 S	*	2/2001	Wu	D34/15
D450,167 S	*	11/2001	Liao	D34/15
D450,902 S	*	11/2001	Liao	D34/15

* cited by examiner

Primary Examiner—Kay H. Chin

(74) *Attorney, Agent, or Firm*—Troxell Law Office PLLC

(57) **CLAIM**

The ornamental design for the double rails golf cart, as shown and described.

DESCRIPTION

FIG. 1 is a perspective view of the double rails golf cart showing the new design;

FIG. 2 is a front view of the new design;

FIG. 3 is a rear view of the new design;

FIG. 4 is a left view of the new design;

FIG. 5 is a right view of the new design;

FIG. 6 is a top view of the new design;

FIG. 7 is a bottom view of the new design;

FIG. 8 is a perspective view showing the design used with a golf bag; and,

FIG. 9 is a perspective view showing the design in folding up condition.

1 Claim, 9 Drawing Sheets

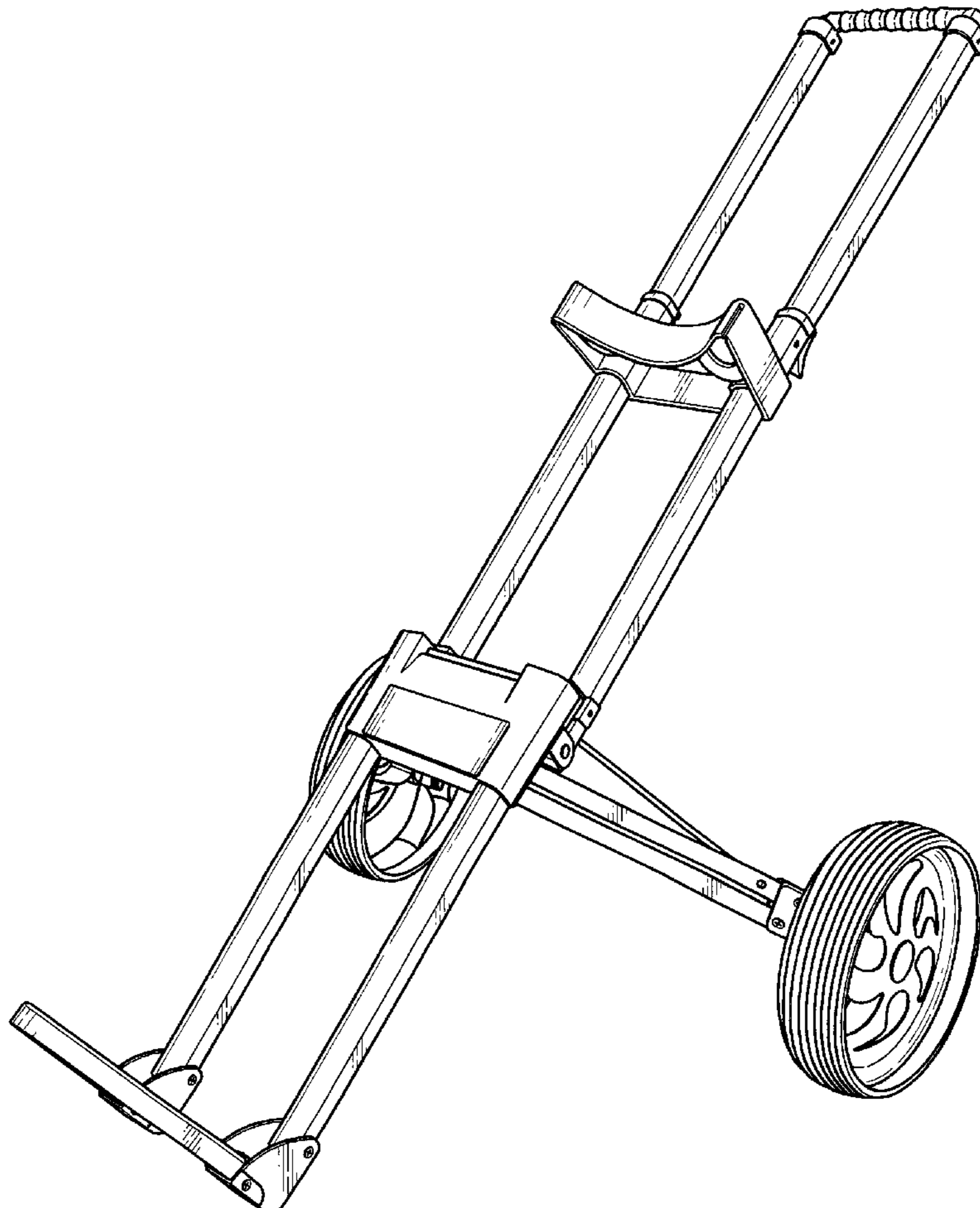

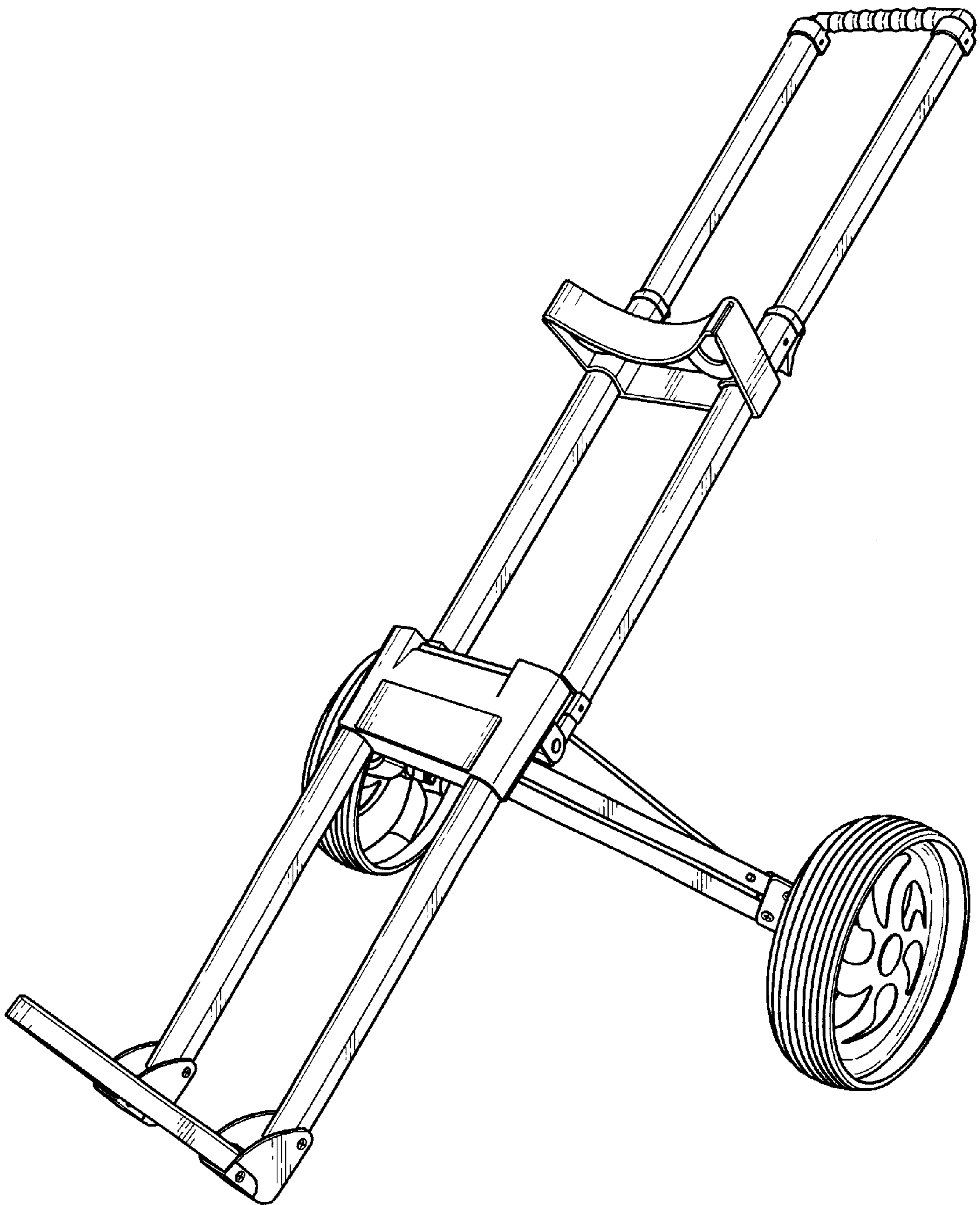

Fig. 1

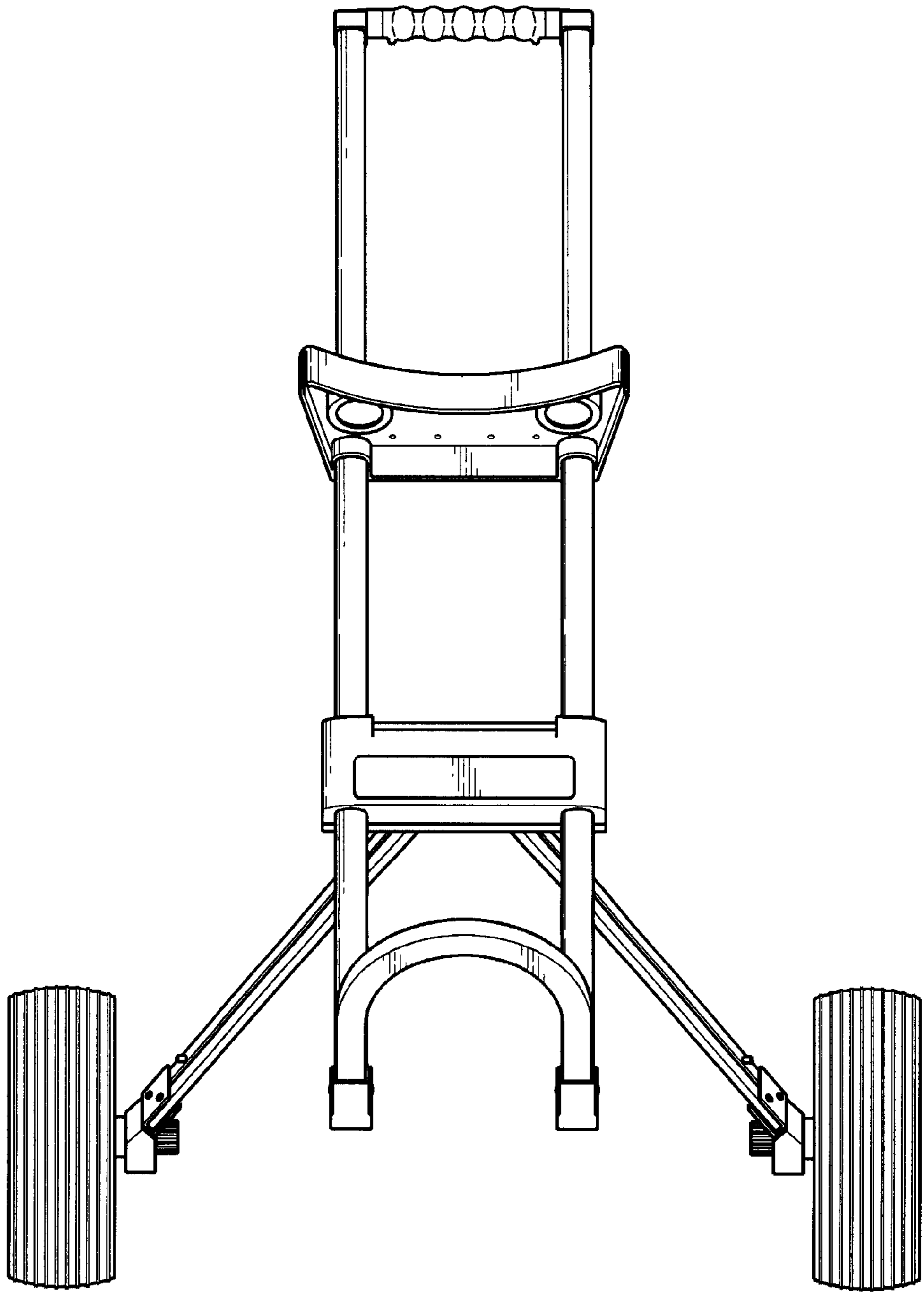

Fig. 2

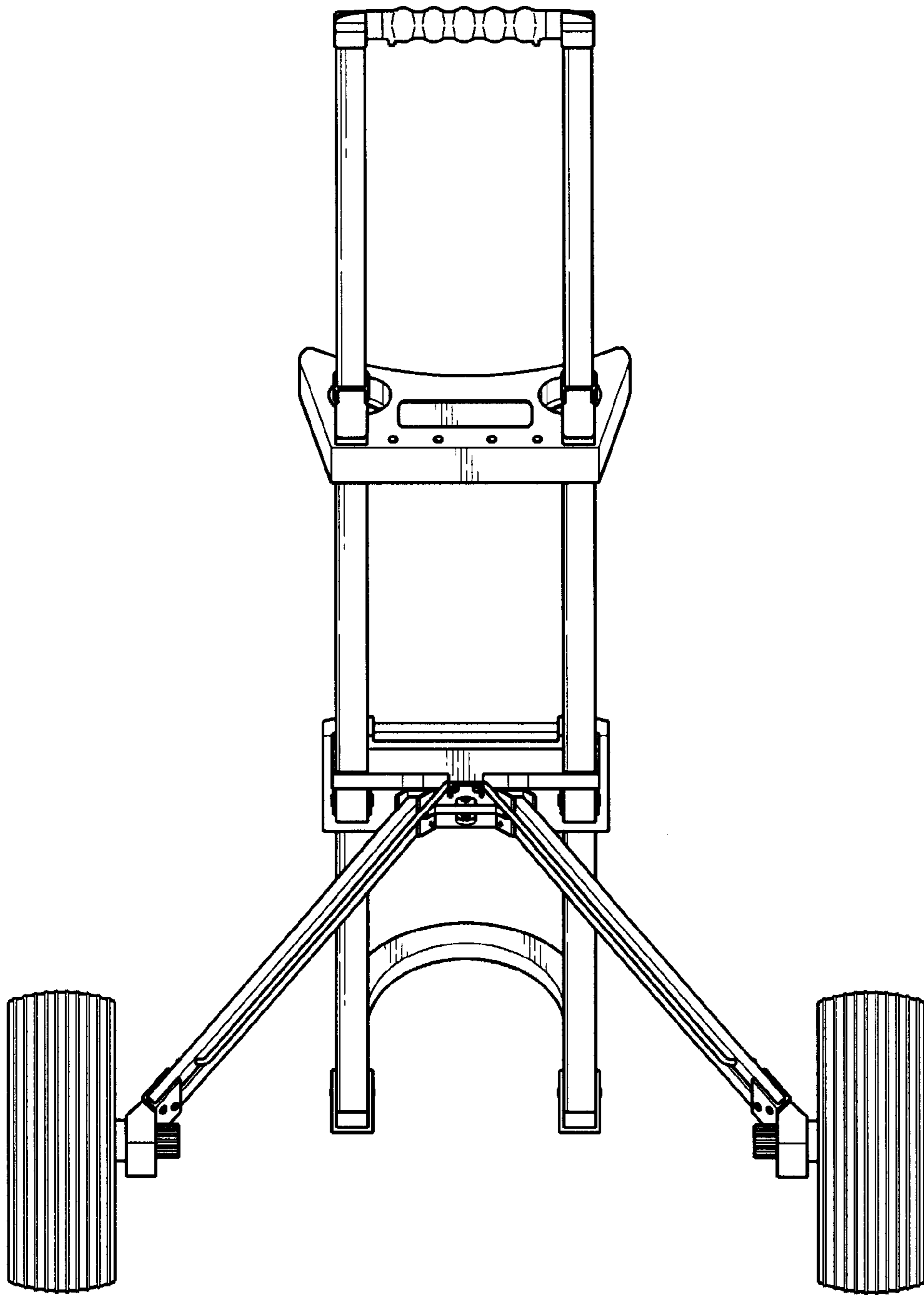

Fig. 3

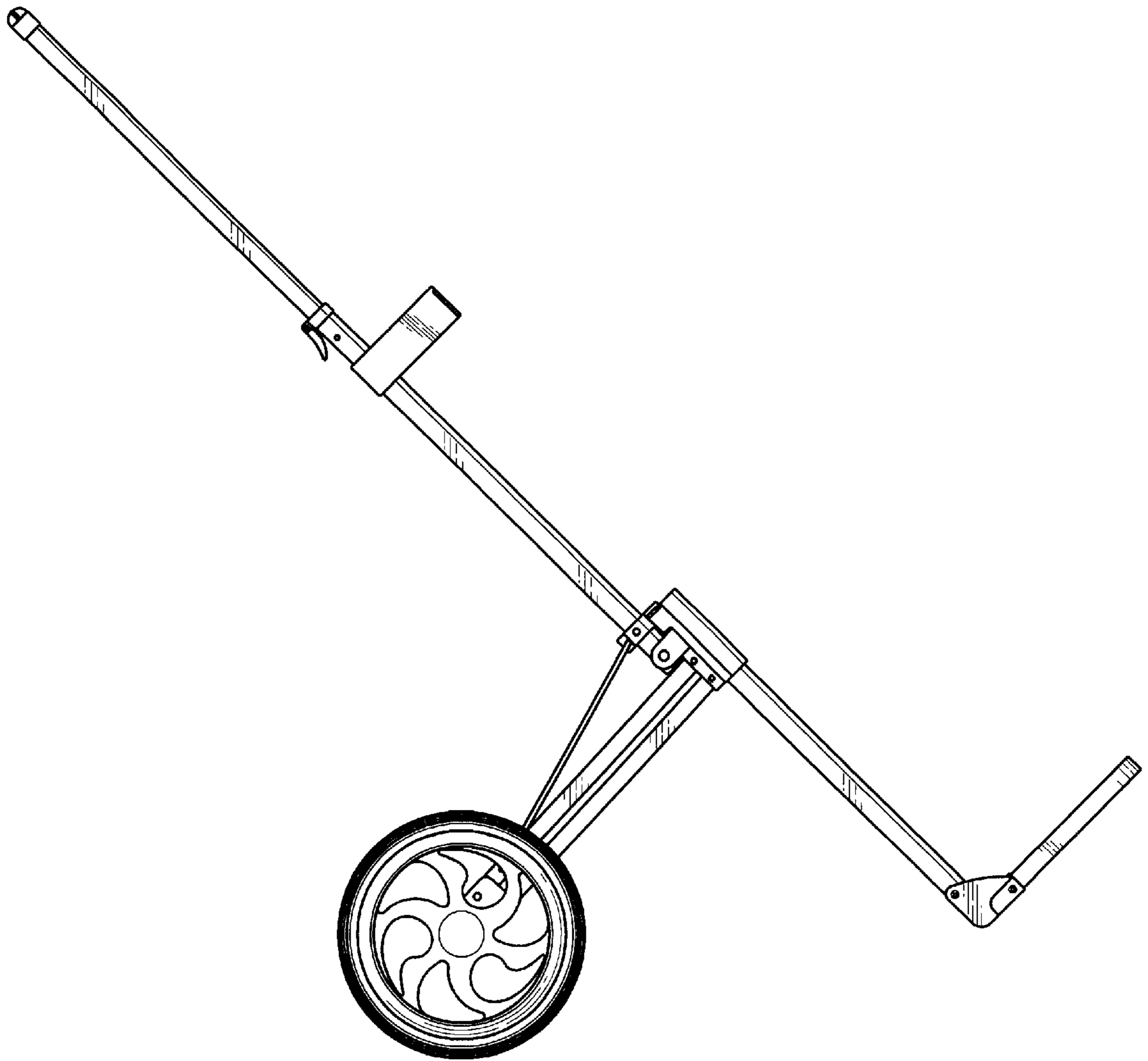

Fig. 4

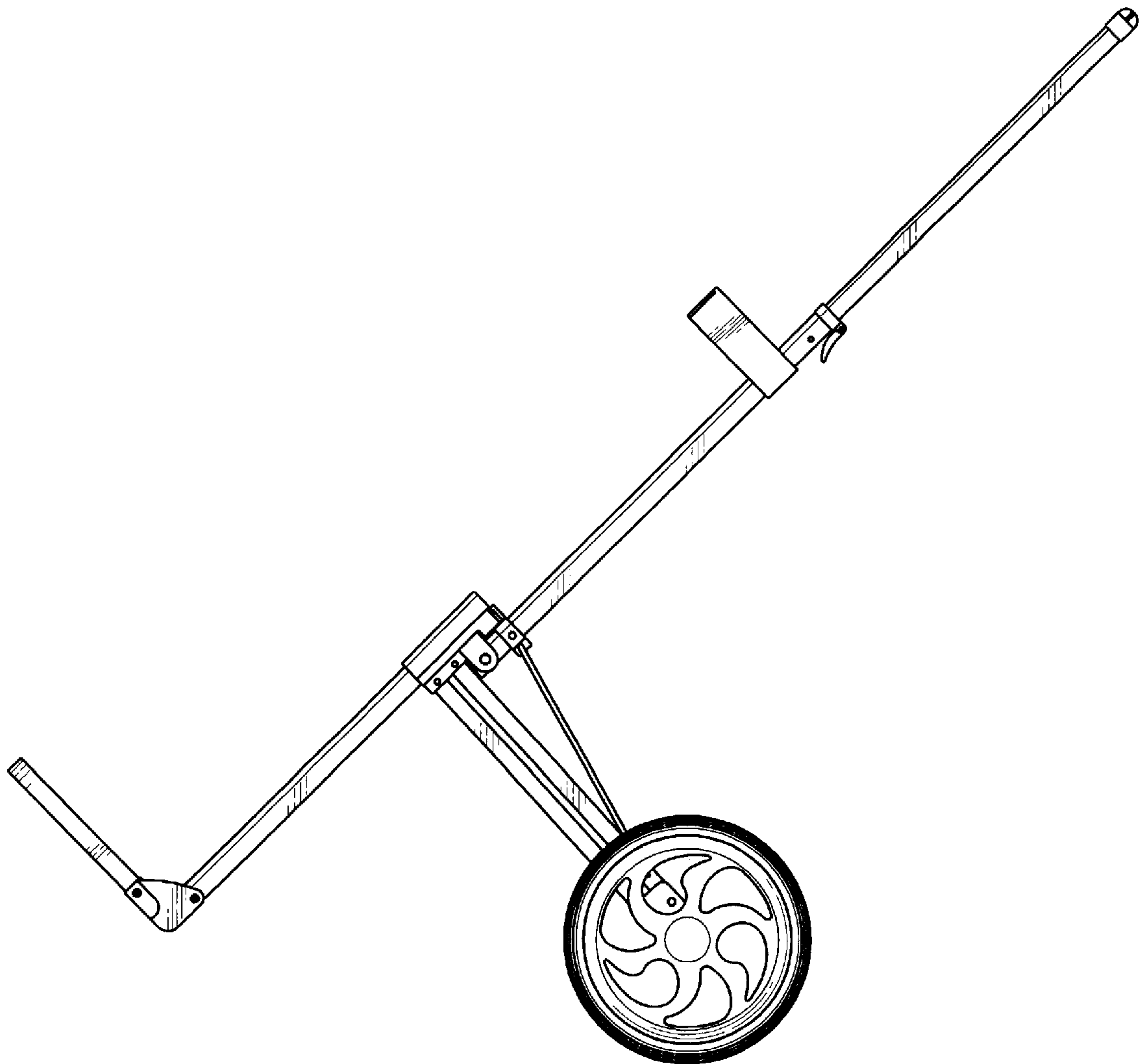

Fig. 5

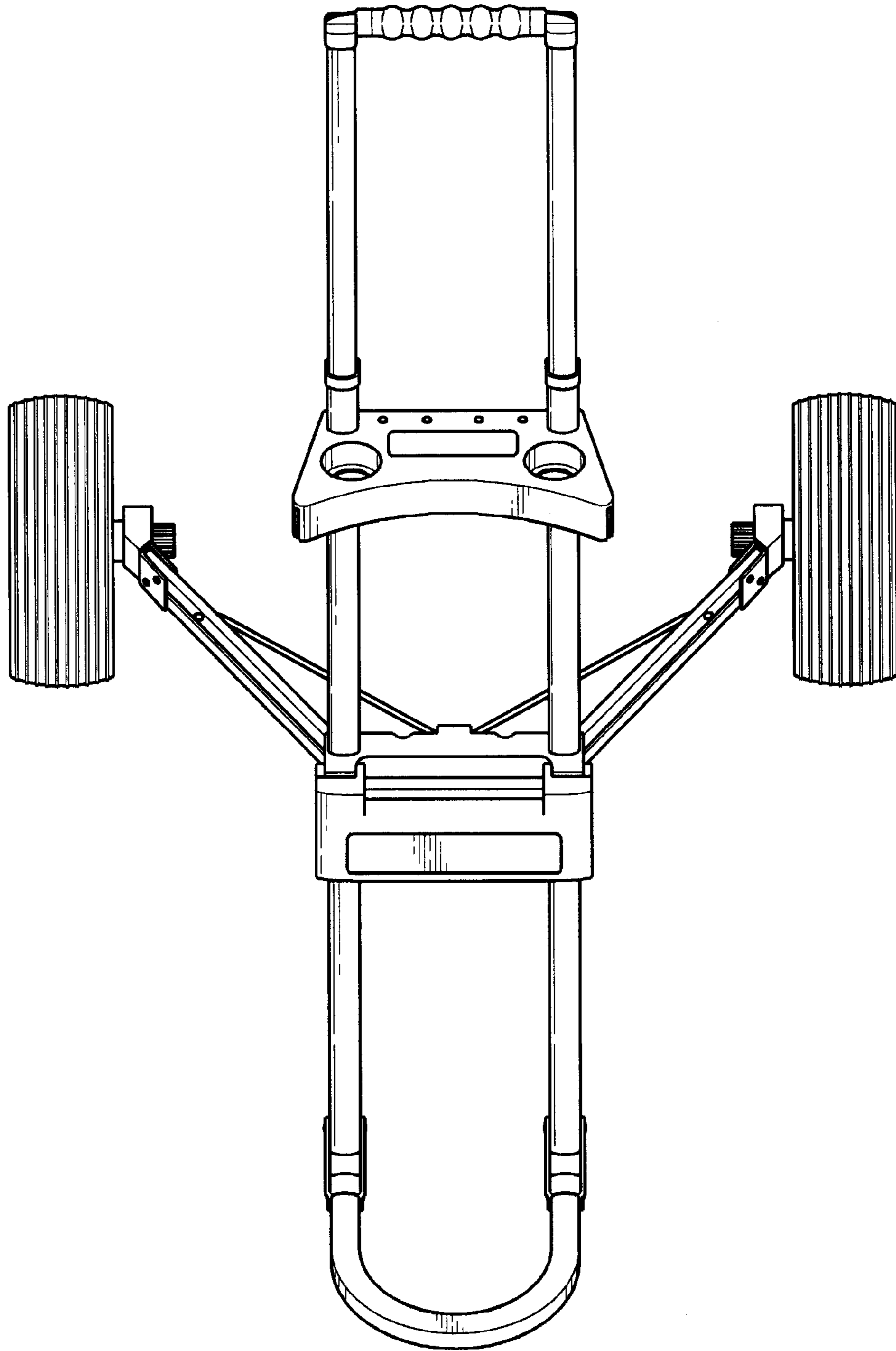

Fig. 6

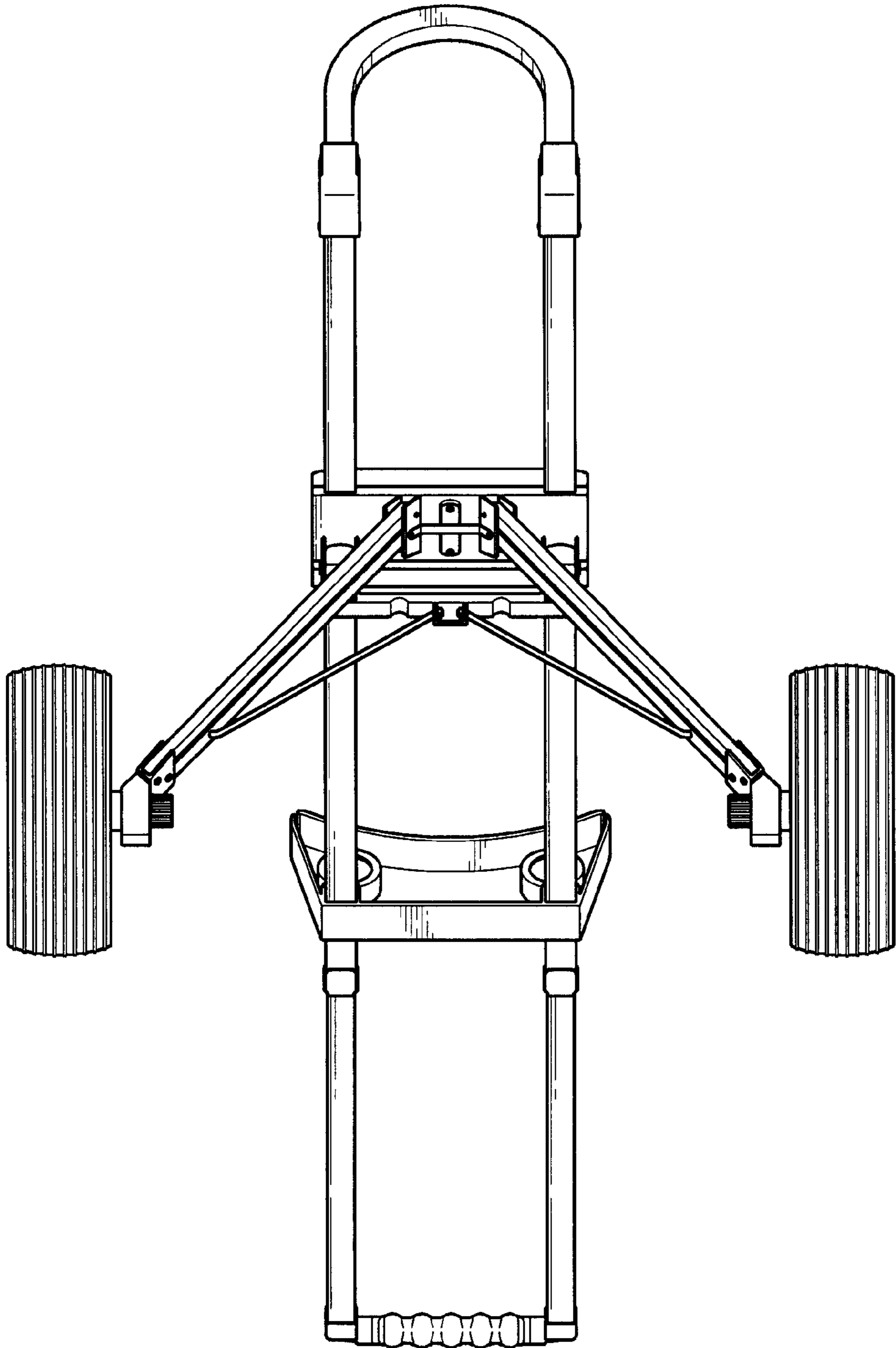

Fig. 7

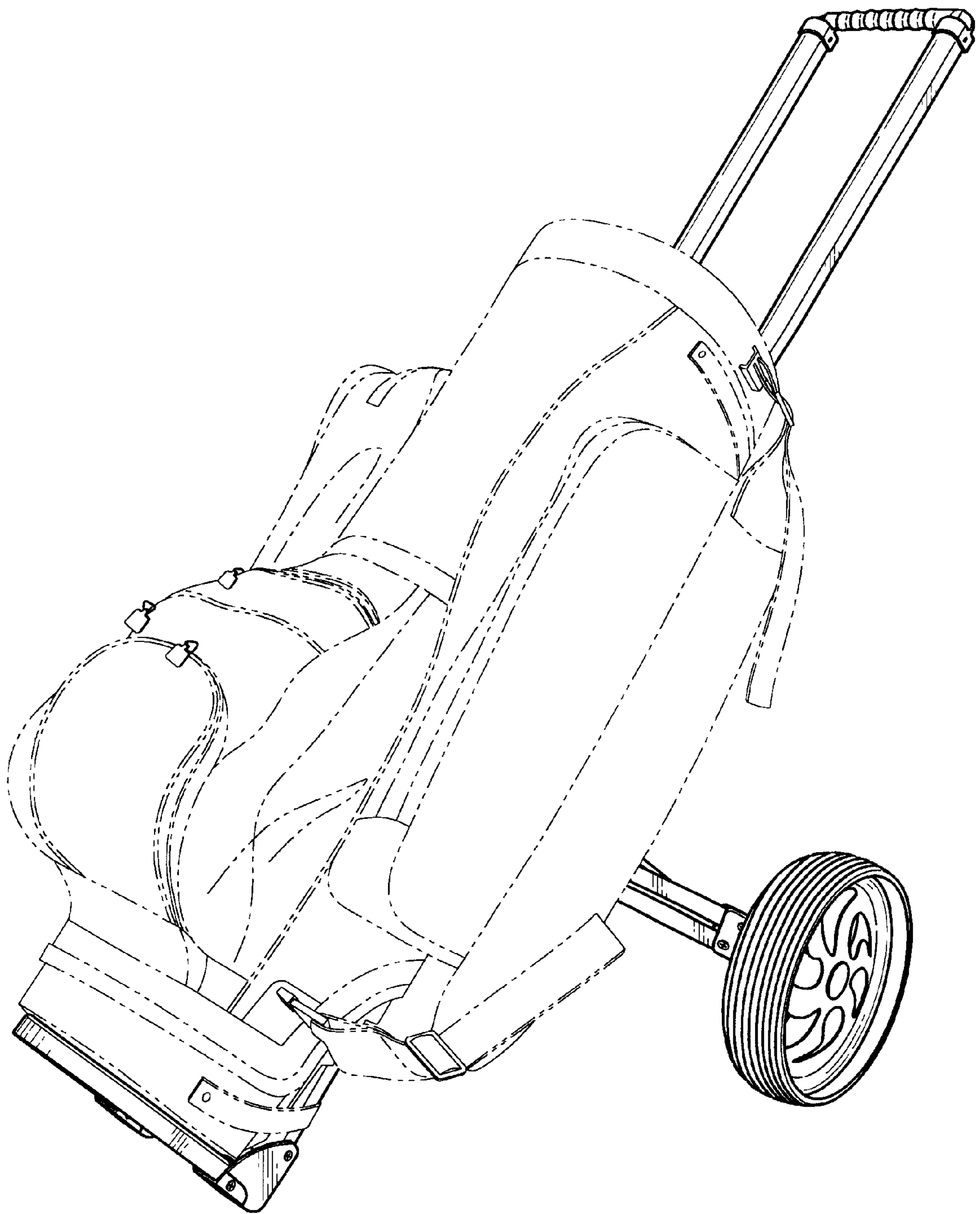

Fig. 8

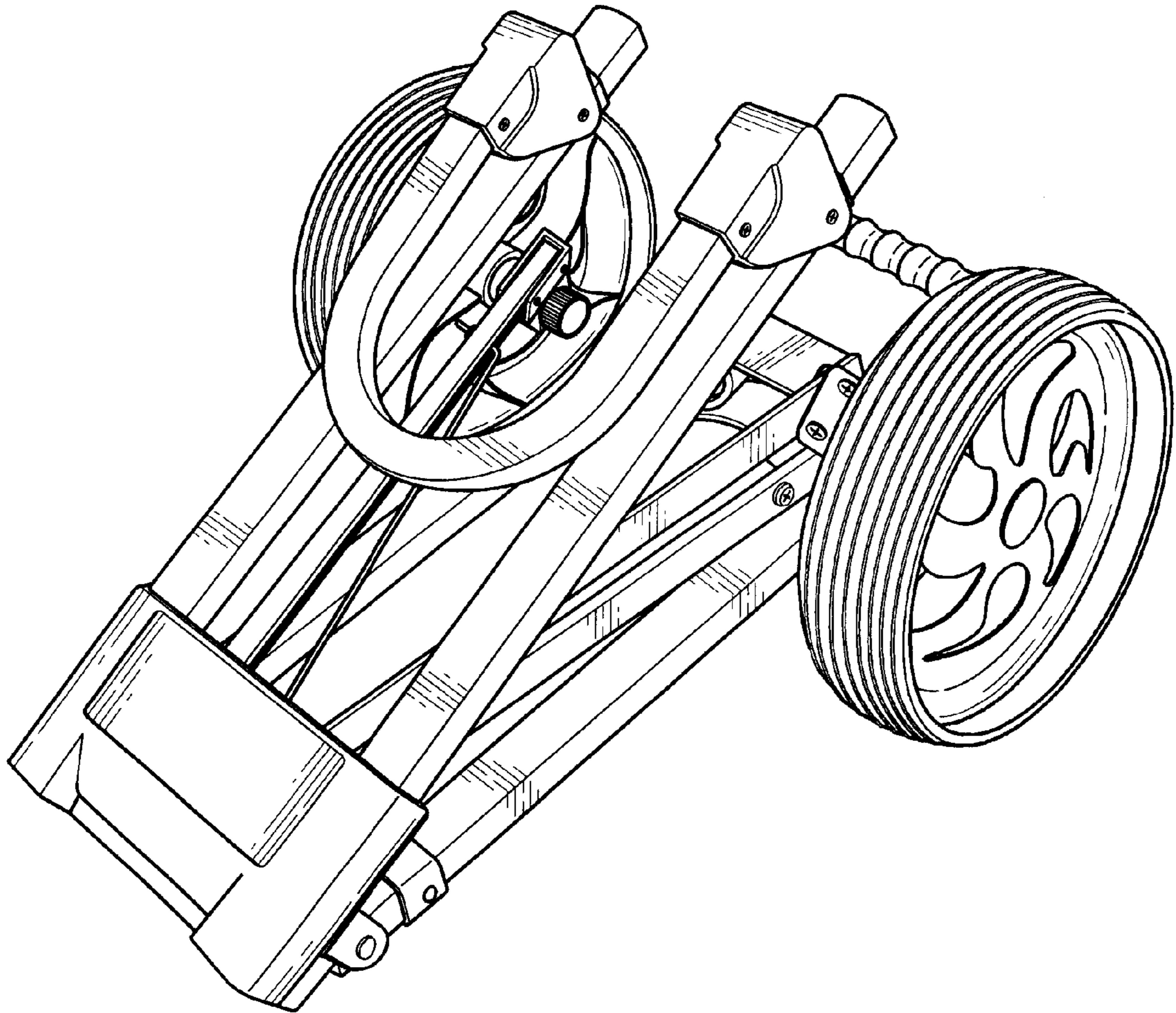

Fig. 9