



US00D481987S

(12) **United States Design Patent**
MacWilliam et al.

(10) **Patent No.:** **US D481,987 S**

(45) **Date of Patent:** **** Nov. 11, 2003**

(54) **REMOVABLE HARDTOP FOR A SPORT UTILITY VEHICLE**

Primary Examiner—Stacia Cadmus
(74) *Attorney, Agent, or Firm*—W. Scott Carson

(75) Inventors: **Roderick J. MacWilliam**, Arvada, CO (US); **Frank A. Borke**, Windsor, CO (US)

(57) **CLAIM**

The ornamental design for a removable hardtop for a sport utility vehicle, as shown and described.

(73) Assignee: **Bestop, Inc.**, Broomfield, CO (US)

DESCRIPTION

(**) Term: **14 Years**

(21) Appl. No.: **29/169,753**

(22) Filed: **Oct. 25, 2002**

(51) **LOC (7) Cl.** **12-16**

(52) **U.S. Cl.** **D12/401**

(58) **Field of Search** D12/401, 404, D12/403, 90–92, 86; 296/210, 218, 213, 224, 102, 10, 183–186, 216, 220–222

FIG. 1 is a front perspective view of a sport utility vehicle with a removable hardtop showing our new design. The vehicle is shown in dotted lines for illustrative purposes only and forms no part of the claimed design.

FIG. 2 is a rear perspective view of the removable hardtop of our new design.

FIG. 3 is a bottom perspective view thereof.

FIG. 4 is a top plan view thereof.

FIG. 5 is a rear elevational view thereof.

FIG. 6 is a front elevational view thereof.

FIG. 7 is a right side elevational view thereof, the left side elevational view being a mirror image thereof.

FIG. 8 is a bottom plan view thereof.

FIG. 9 is a rear perspective view of a second embodiment of the removable hardtop for a sport utility vehicle of our new design.

FIG. 10 is a bottom perspective view thereof.

FIG. 11 is a top plan view thereof.

FIG. 12 is a rear elevational view thereof.

FIG. 13 is a front elevational view thereof.

FIG. 14 is a right side elevational view thereof, the left side elevational view being a mirror image thereof; and,

FIG. 15 is a bottom plan view thereof.

FIGS. 2–8 are shown on an enlarged scale compared to FIG. 1.

(56) **References Cited**

U.S. PATENT DOCUMENTS

| | | | | | |
|------------|---|---------|---------------|-------|---------|
| D235,536 S | * | 6/1975 | Boston | | D12/401 |
| D249,497 S | * | 9/1978 | Slider | | D12/401 |
| D251,191 S | * | 2/1979 | Dix | | D12/401 |
| D254,247 S | * | 2/1980 | Le Van et al. | | D12/401 |
| D304,436 S | * | 11/1989 | Pike | | D12/401 |
| D324,196 S | * | 2/1992 | Muth | | D12/401 |
| D368,064 S | * | 3/1996 | Speece | | D12/404 |
| D374,651 S | * | 10/1996 | Townsend | | D12/401 |
| D382,246 S | * | 8/1997 | DeGaillard | | D12/401 |
| D408,781 S | * | 4/1999 | Gordon | | D12/401 |
| D438,840 S | * | 3/2001 | Dowdey | | D12/404 |
| D442,911 S | * | 5/2001 | Essig et al. | | D12/404 |

* cited by examiner

1 Claim, 13 Drawing Sheets

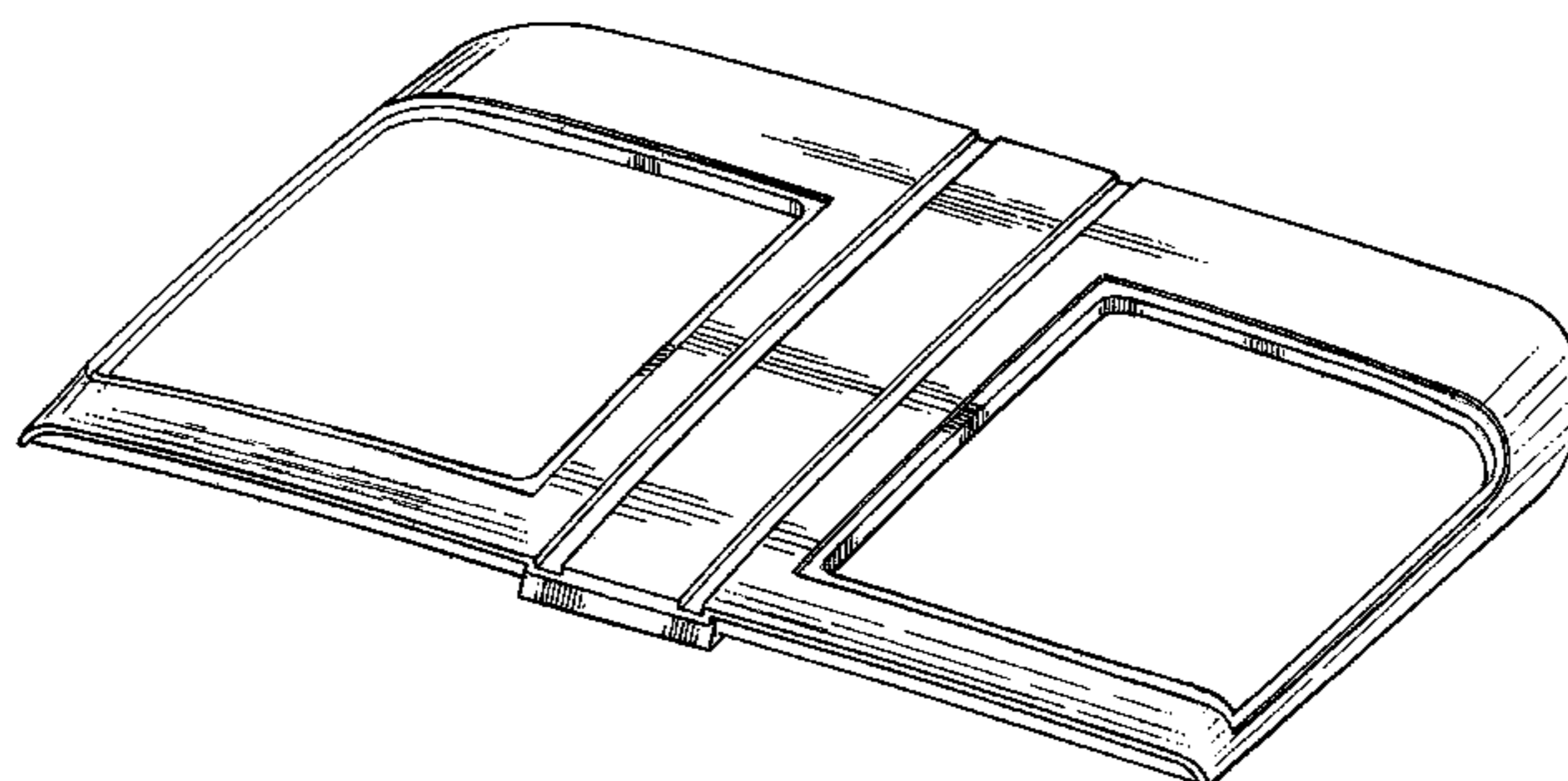
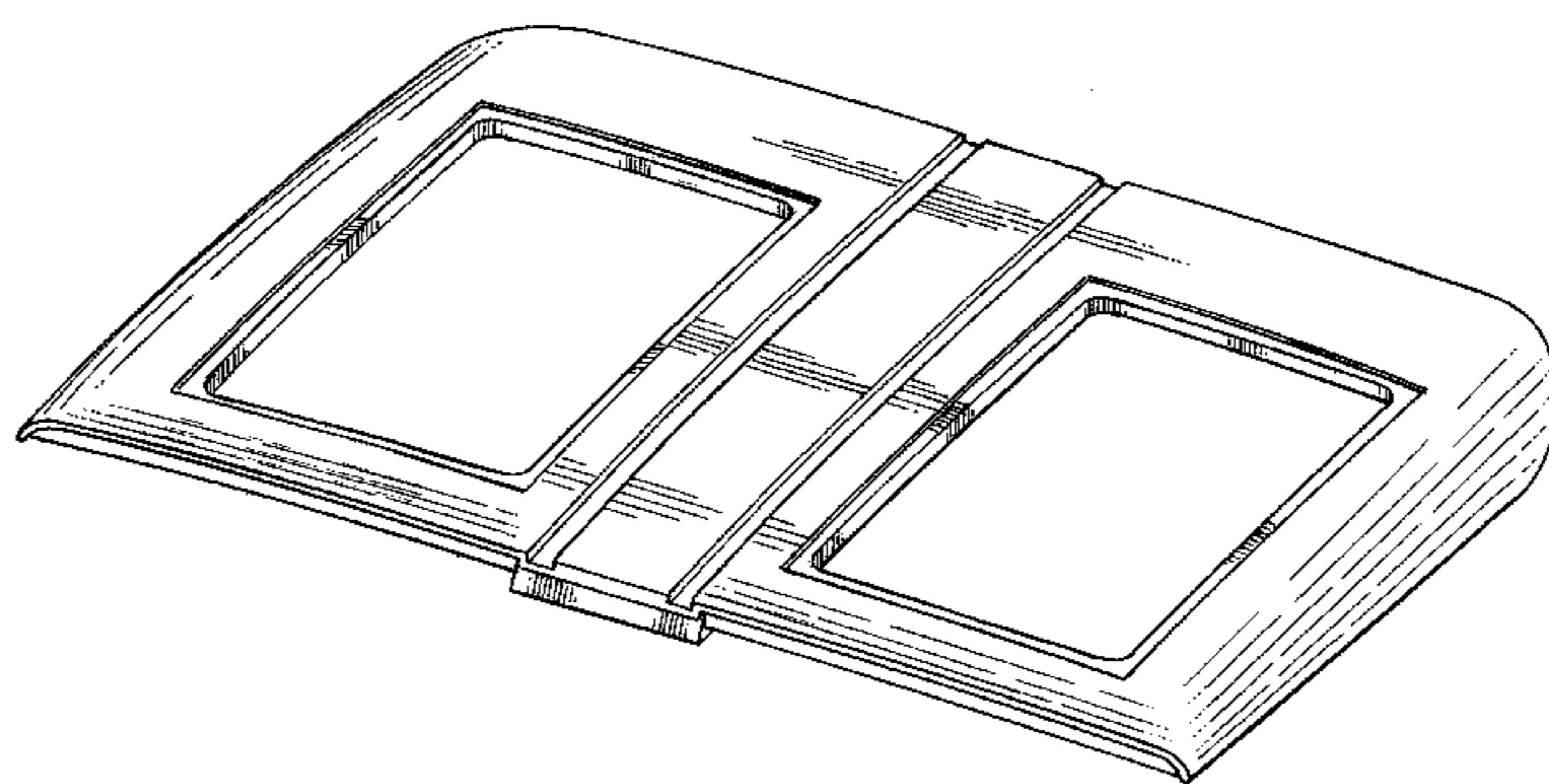
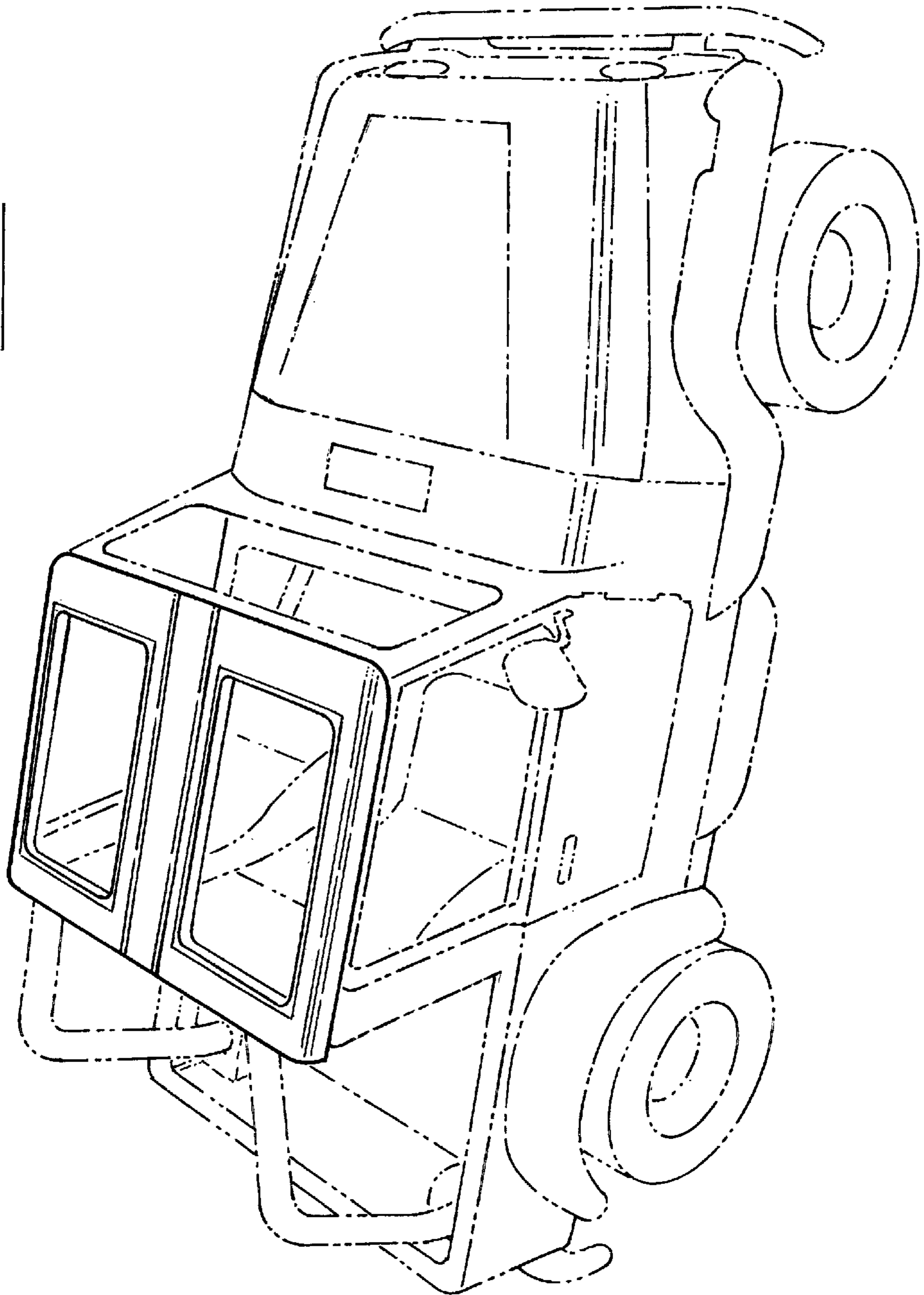

Fig. 1



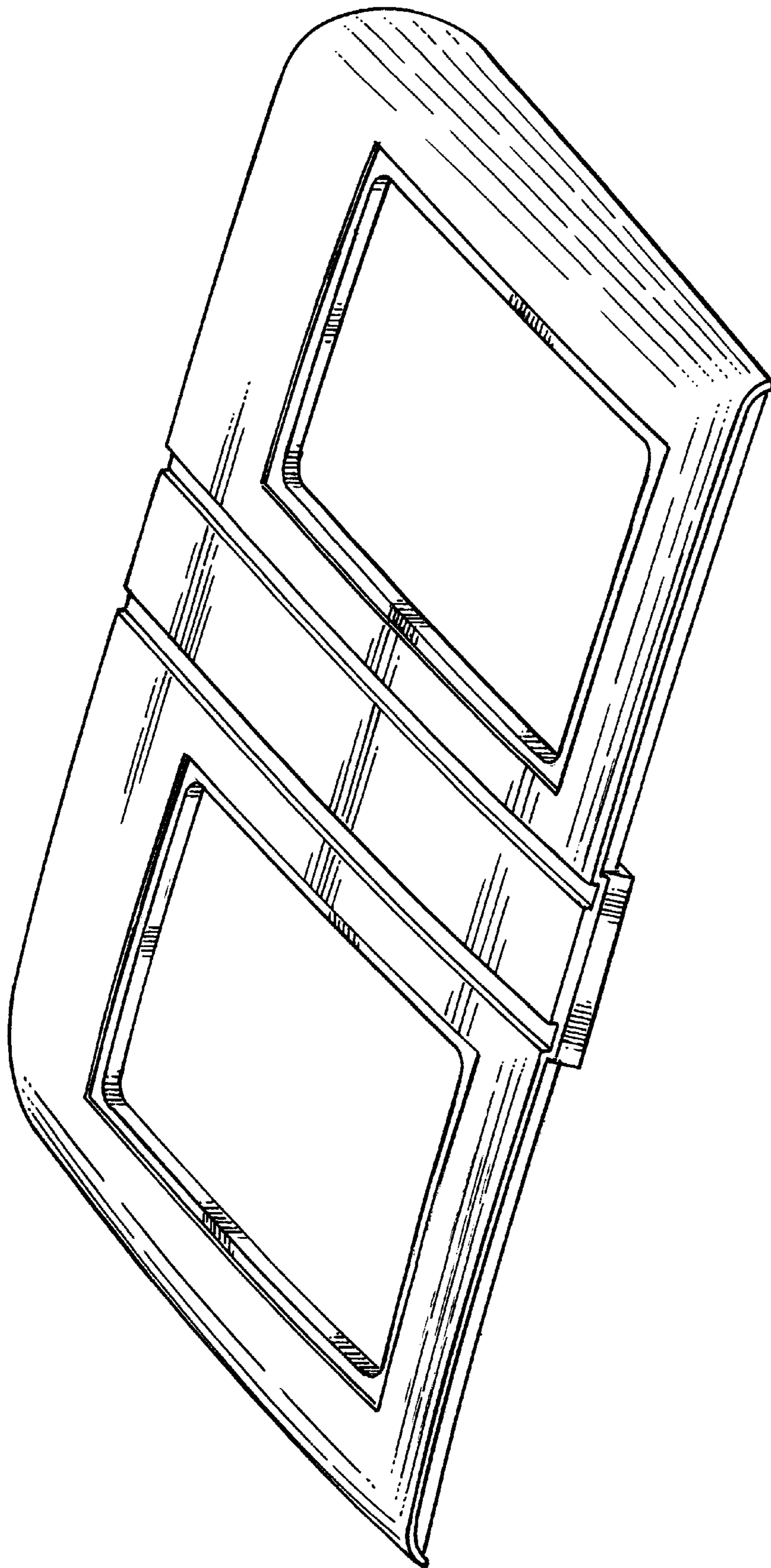

Fig. 2

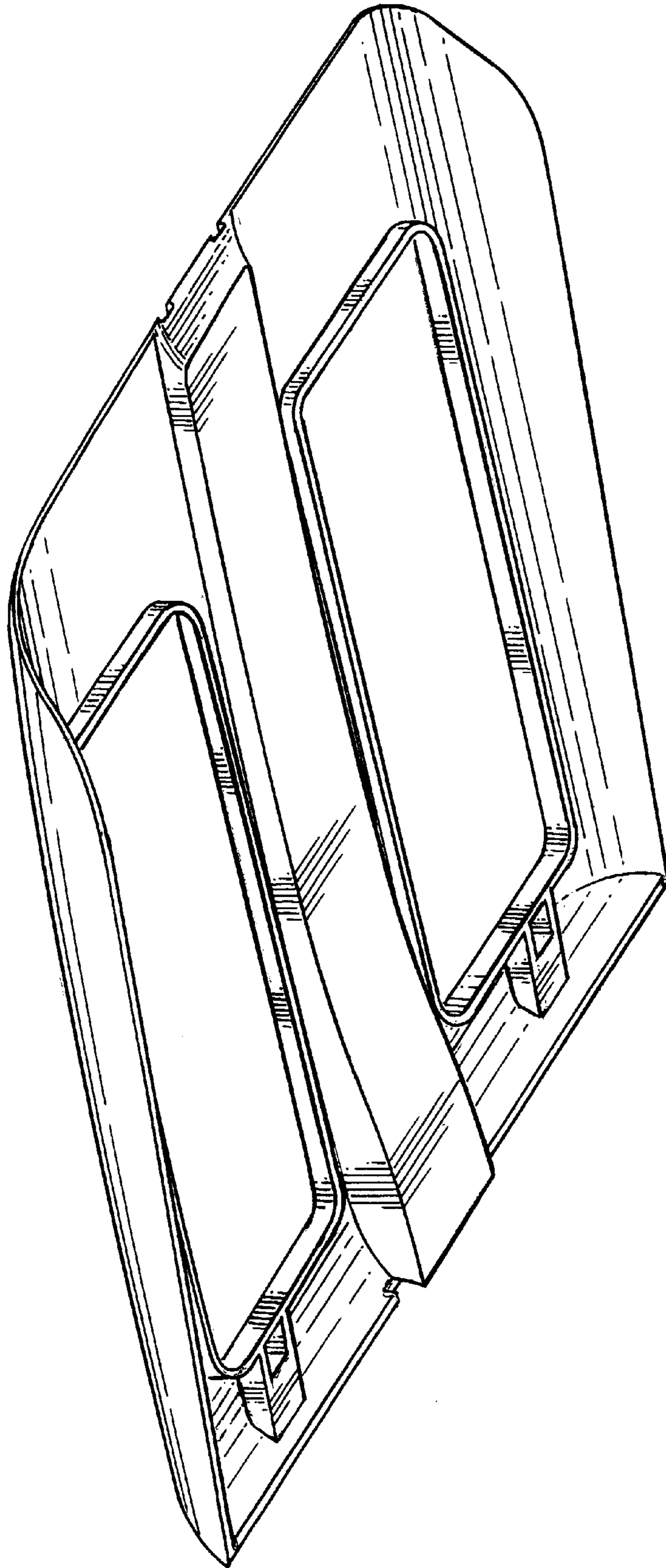

Fig. 3

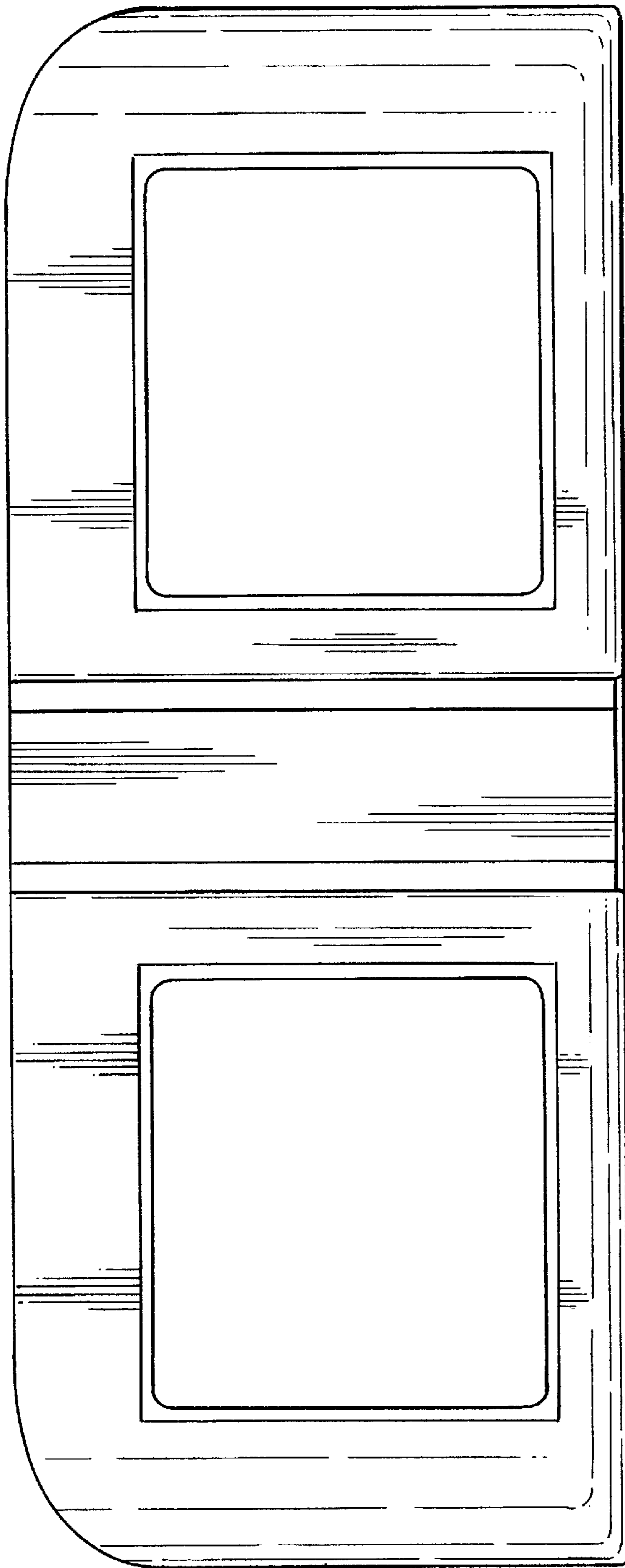

Fig. 4



Fig. 5

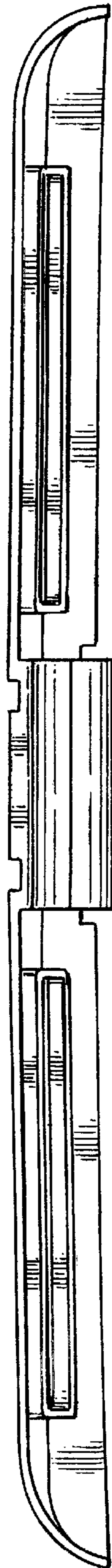

Fig. 6

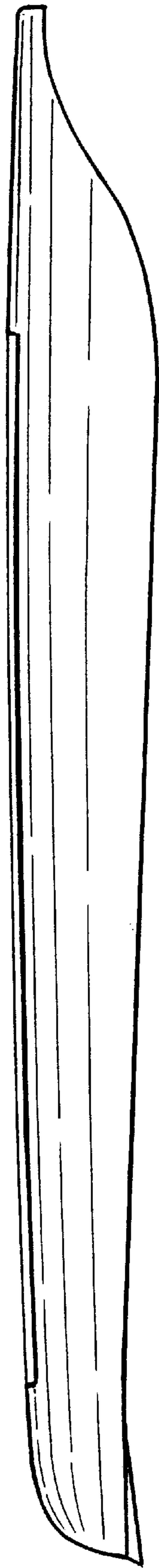

Fig. 7

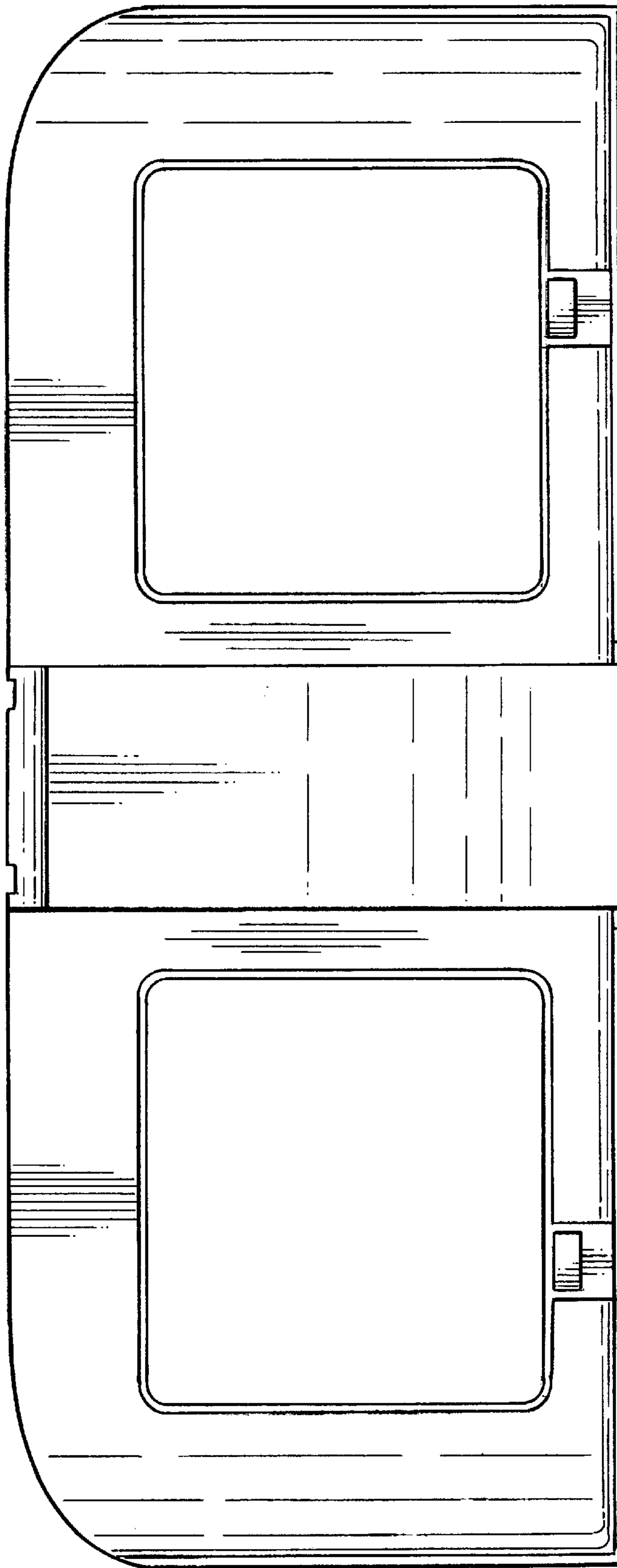

Fig. 8

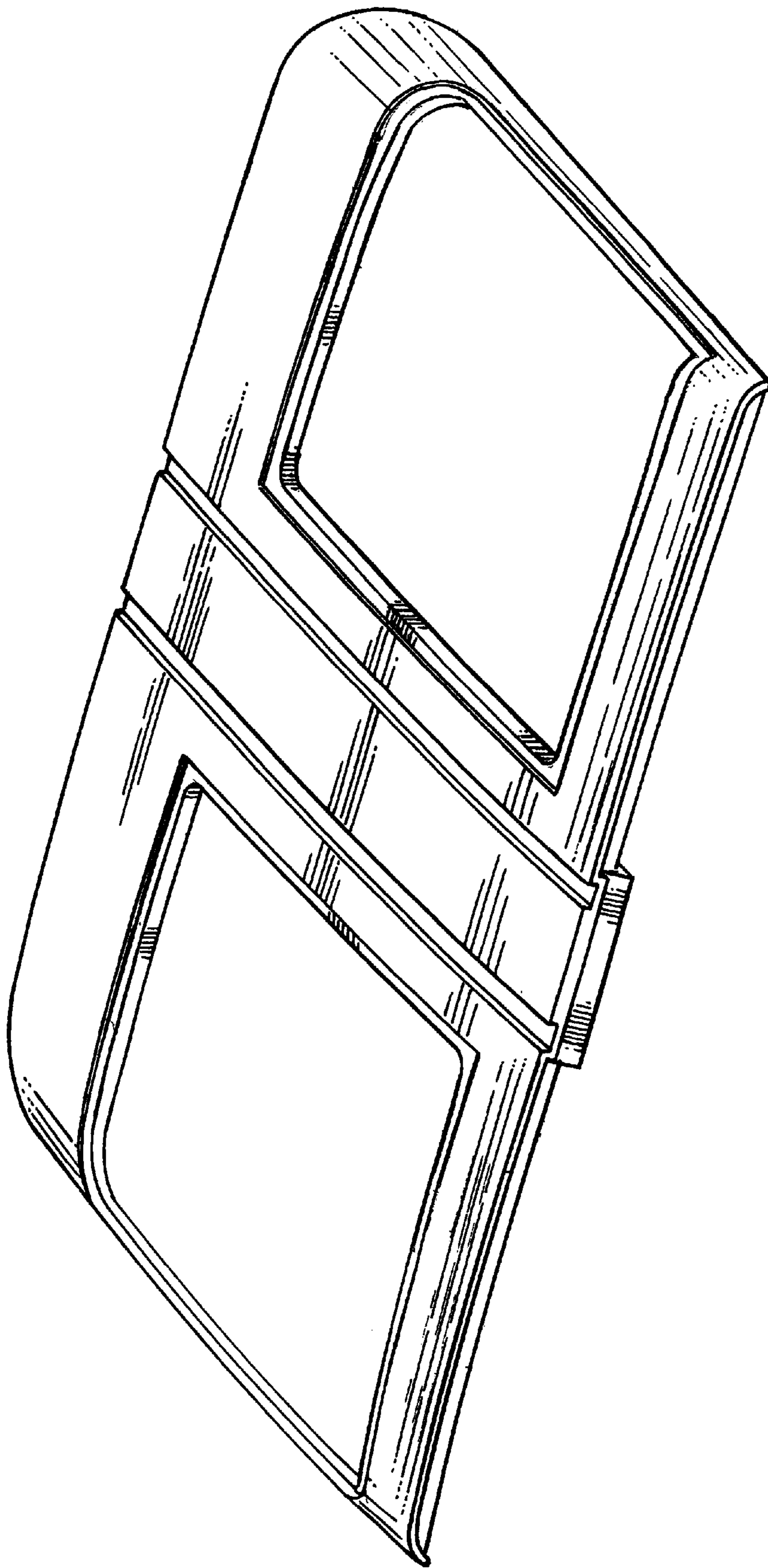

Fig. 9

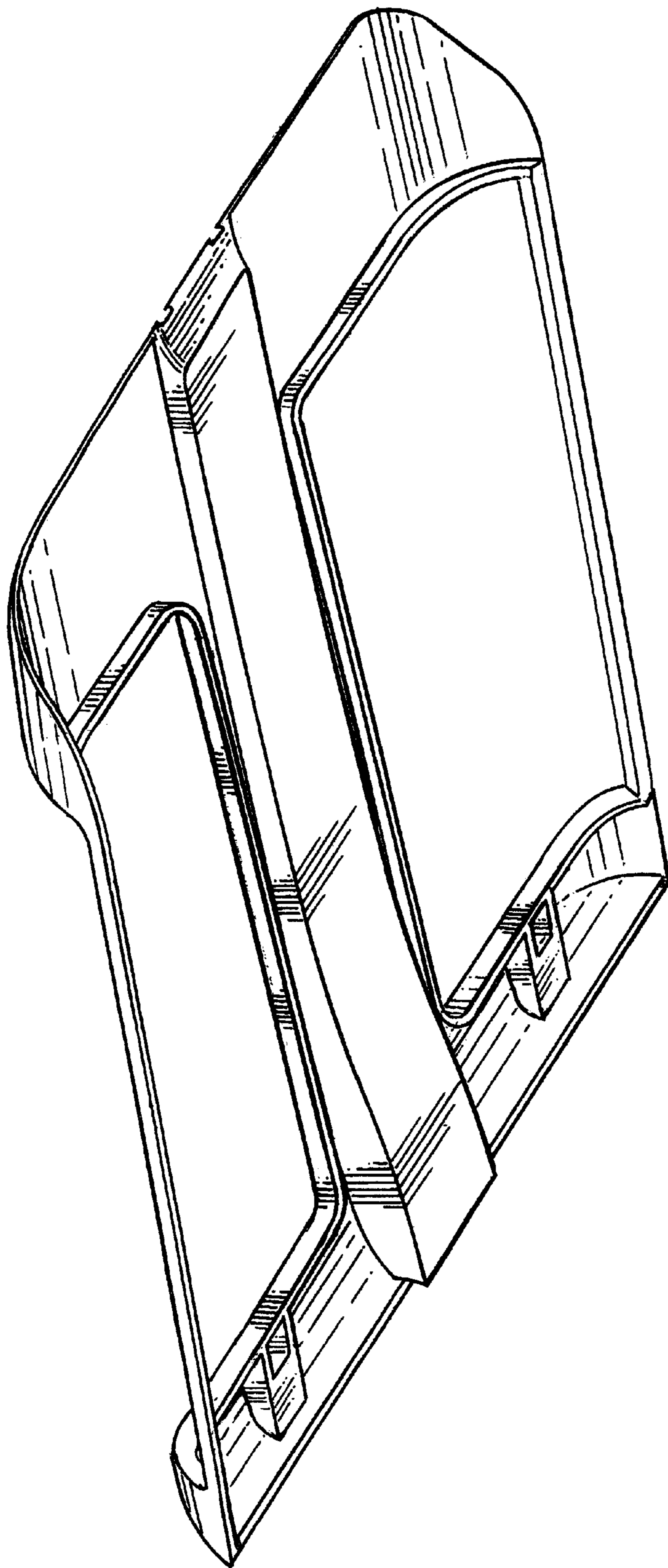

Fig. 10

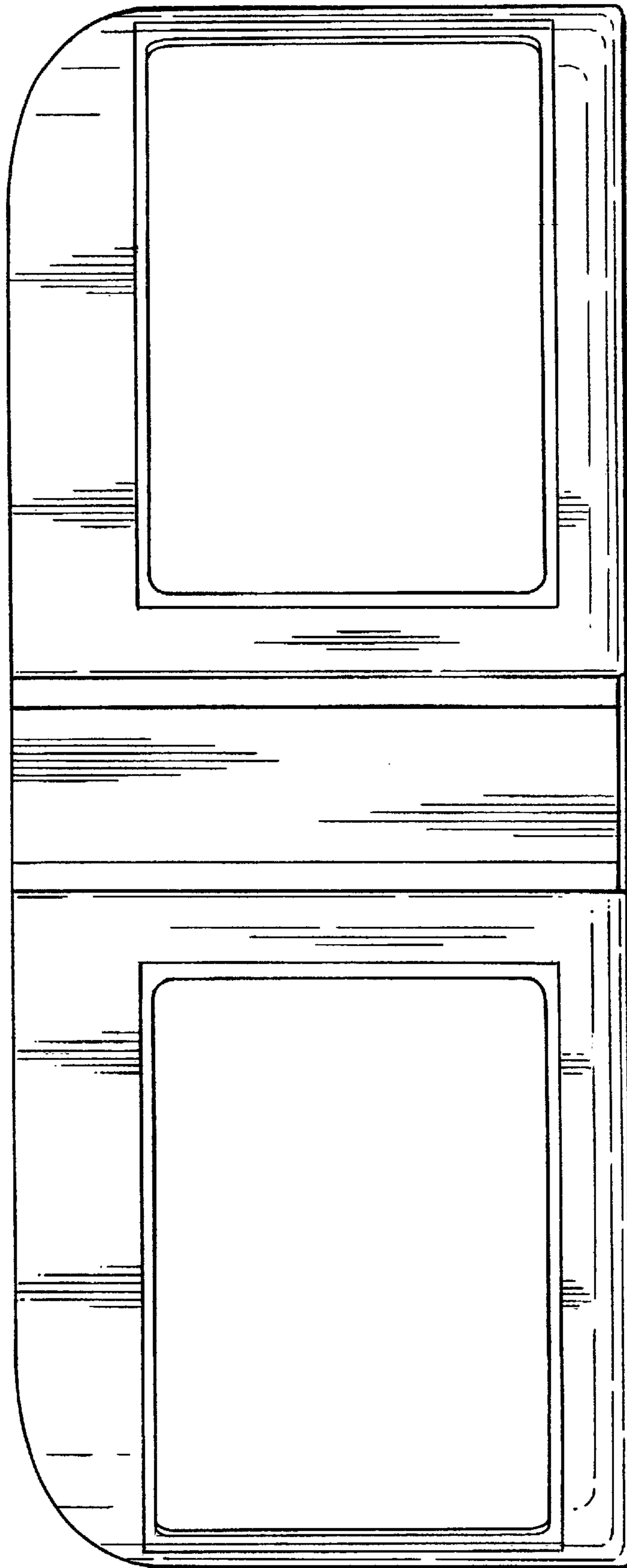

Fig. 11

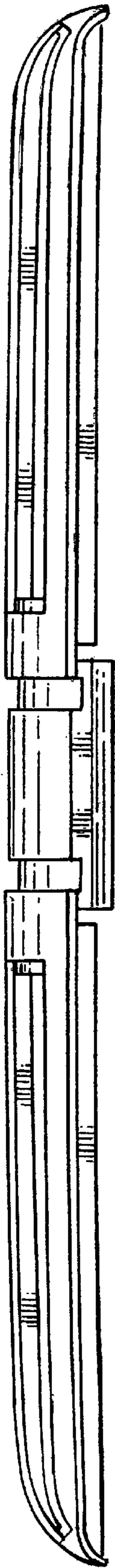

Fig. 12

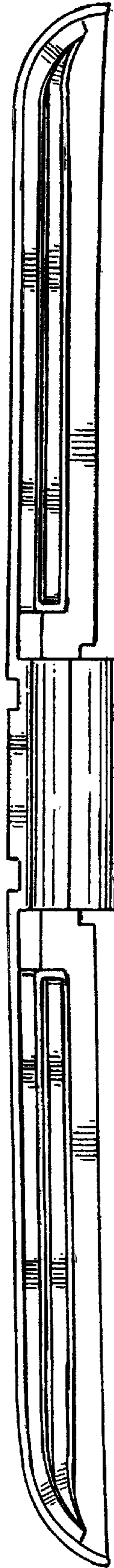

Fig. 13

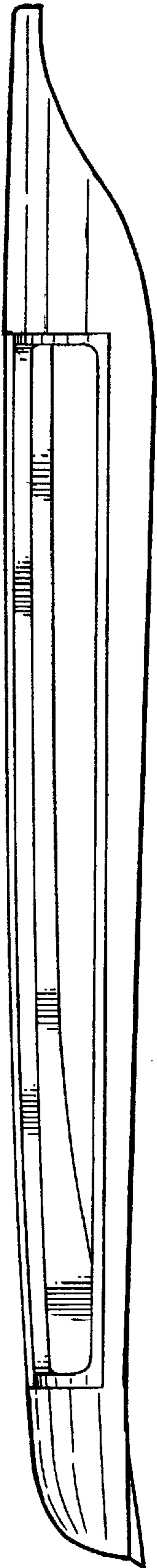

Fig. 14

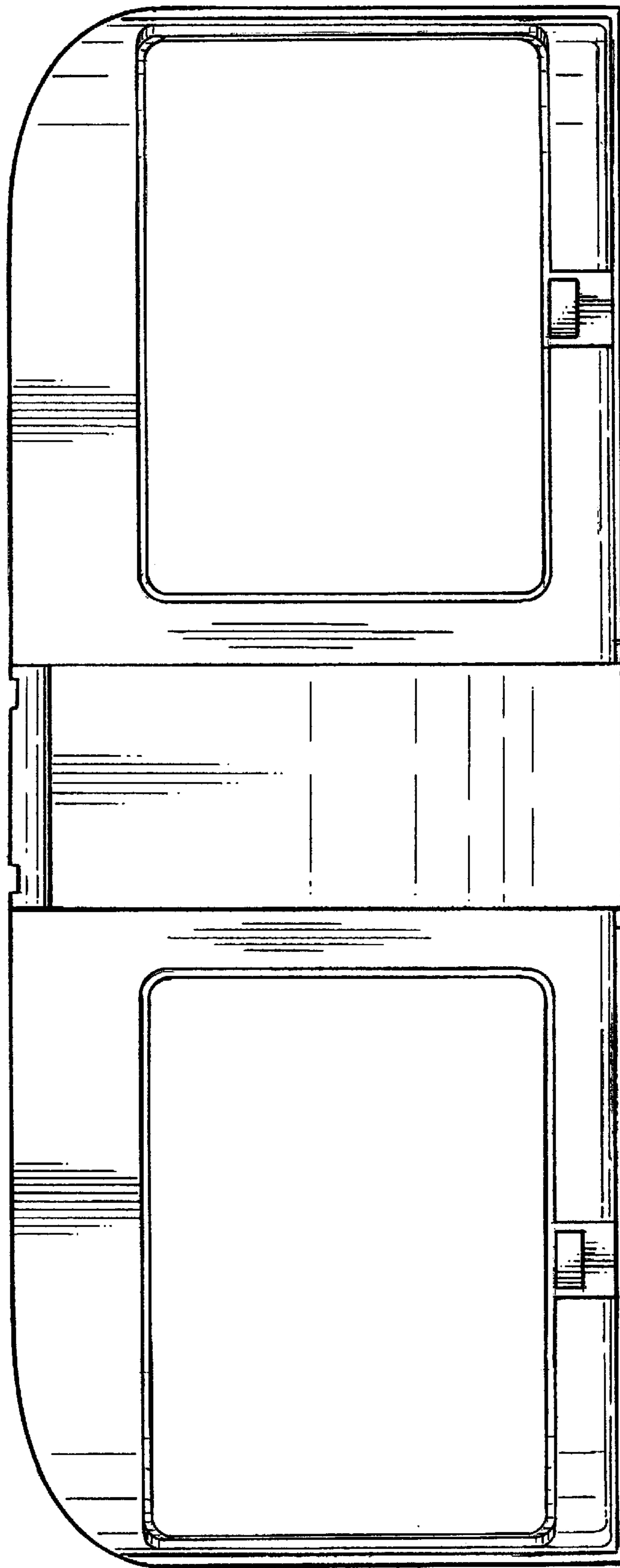

Fig. 15